

## Contents

Editorial .....	iii
WCSB10 Sponsors .....	vi
WCSB10 Partners .....	vii
Proceedings Contents .....	viii
Author Index .....	x
Acknowledgement of Reviewers .....	xi
Technical Program .....	xii
Orals .....	1
Posters .....	439



# Proceedings of the 10<sup>th</sup> World Conference on Sampling and Blending

Edited by Kim H. Esbensen and Anne J. Cole



# INDUSTRY FOR THE FUTURE

TOWARDS A SUSTAINABLE  
PROCESS INDUSTRY

RENEWABLE ENERGY  
MAKES  
SUSTAINABLE  
MATERIALS



**EYDE**  
CLUSTER

NCE EYDE Norwegian Center of Expertise  
Sustainable Process Industry

[www.eydecluster.com](http://www.eydecluster.com)

## Editorial

This issue of *TOS Forum* is a dedicated publication of the Proceedings of the 10<sup>th</sup> World Conference on Sampling and Blending, WCSB10. The editorial process started in February–March 2020 when it was realised that the global COVID-19 pandemic would likely also impact on the small community of professionals interested in sampling—although most hoped for a brief disruptive period only. The virus sadly had other ideas, and the chain of the regular bi-annual WCSB conference schedule was broken for the first time. However, now it is finally time to meet again in-person with only a minimum of streaming contributions and attendees.

The prospects for adequate sponsoring of a world conference were largely unknown after three years of inactivity, but the WCSB10 organisational and scientific committees decided to plan for success—and the publication of these proceedings is a testimony to the validity of that decision. However, it was felt that economic prudence was in any event called for with respect to the costs involved. Which is why the editorial responsibilities and the ensuing publication tasks for WCSB10 build directly on the earlier WCSB7 Proceedings' minimalist strategy based on a very small but effective production setup, in fact today consisting of an editorial staff of two (in Copenhagen), and the IM Publications team (in Chichester).

The Editorial staff acknowledges and extends a very big thank you to:

**The reviewers:** Francis Pitard, Richard Minnitt, Pentti Minkinen, Stéphane Brochot, Dominique François-Bongarçon, Claudia Paoletti, Simon Dominy, Ralph Holmes, Martin Lischka, Aldwin Vogel, Trevor Bruce, Oscar Dominguez, Karin Engström, Dr Li Huachang, Quentin Dehaine, Roger Brewer, Bert Pauels. The reviewers'

work is the invaluable backbone of any conference, guaranteeing scientific standard and integrity.

**The Publisher:** IMP Open is thanked for its highly effective and forthcoming collaboration, which is the main reason behind the impeccable professional, pleasing appearance of this publication: Thank you very much, Ian and Katie!

**The sponsors:** The WCSB10 Proceedings are kindly supported by forward-looking organisations, companies and individuals, all acknowledged by their logos in this publication. The scientific work of the IPGSA could not take place were it not also from this generous support—which is gratefully acknowledged.

After the conference is over, the WCSB10 Proceedings will be the lasting physical documentation available to posterity. Publishing traditions have come a long way since WCSB7 (2015), where the proceedings appeared both as a conventional printed issue, as an accompanying USB stick, as well as being freely available on the Internet as an Open Access publication. The latter has shown to be the most important dissemination option in the broader historical view, so much so that this is now the only documentation format offered. With all the above, the Editors and the Publisher are satisfied with the way the present contributions are available to the interested reader.

Producing this publication in the spring of 2022, in part ruled by the declining COVID-19 pandemic and its tail-end resurgences, has not been an easy job. However, it has been a tremendously rewarding task, because of the privilege of performing this scientific public service for the International Pierre Gy Sampling Association (IPGSA), it has also been our pleasure.

*Kim H. Esbensen,*

*Editor WCSB10 Proceedings*

*Anne J. Cole,*

*Co-editor, WCSB10 Proceedings*

This issue comprises the Proceedings of the 10<sup>th</sup> World Conference on Sampling and Blending, held from 31 May to 2 June in Kristiansand, Norway.



## Proceedings of the 10<sup>th</sup> World Conference on Sampling and Blending

EDITORS

Kim H. Esbensen (KHE Consulting)

Anne J. Cole (ReConsider Company)

[www.impopen.com/wcsb10](http://www.impopen.com/wcsb10)

EDITOR

Kim H. Esbensen Owner, chief consultant, independent researcher at KHE Consulting, Denmark, [khe.consult@gmail.com](mailto:khe.consult@gmail.com); guest-, associate-, visiting professor (Denmark, Norway, Puerto Rico, Quebec).

PUBLISHER

Ian Michael ([ian@impopen.com](mailto:ian@impopen.com))

©2022 IM Publications Open LLP

6 Charlton Mill, Charlton, Chichester, West Sussex PO18 0HY, UK.  
Tel: +44-1243-811334;  
Fax: +44-1243-811711;  
E-mail: [subs@impopen.com](mailto:subs@impopen.com)

IMPublicationsOpen

*TOS forum* is currently available free-of-charge. Visit [www.impopen.com/tos-forum](http://www.impopen.com/tos-forum) for details.

Editorial correspondence to Kim Esbensen, [khe.consult@gmail.com](mailto:khe.consult@gmail.com). All production correspondence should be sent to *TOS forum*, 6 Charlton Mill, Charlton, Chichester, West Sussex PO18 0HY, UK, Tel: +44(0)1243-811334, Fax: +44(0)1243-811711, e-mail: [ian@impopen.com](mailto:ian@impopen.com).

FOLLOW US ON  
SOCIAL MEDIA



VISIT OUR  
WEBSITE



**PUSHING  
THE LIMITS  
TOGETHER**

**Our pure  
nickel creates  
technology for  
the green  
shift**

We support the UN sustainability development goals for a cleaner, safer and more just world, and focus especially on the following goals:



**NIKKELVERK**  
A GLENCORE Company



# OPTIMUM PRODUCT QUALITY. IT ALL STARTS WITH RELIABLE DATA

## KEY BENEFITS

- Greater control over the life of your mine
- A better-quality product – and the proof to back it up
- Improved profitability and process efficiency

Miscalculations can cost more than just money. If your product doesn't meet the required quality standards, you lose customer trust. Correct sampling and analysis of your product enables you to establish its worth, both as a seller and a buyer. Accuracy is the key to building customer trust.

For more information  
[flsmidth.eco/37E0kkA](https://flsmidth.eco/37E0kkA)

**WE DISCOVER POTENTIAL**

**FLSMIDTH**

## Silver Sponsors



## Bronze Sponsors



**MULTOTEC**



## Partners



Kristiansand  
kommune



◆ KREMEN AV ISKREM ◆



With funding from  
The Research Council of Norway



SPAREBANKEN SØR



- 1** The complex futility of the Liberation Factor  
*F.F. Pitard*
- 7** Liberation factor for ‘closely sieved’ material  
*D. Francois-Bongarcon*
- 11** Theory of Sampling and QAQC enabling the application and expectations of new technology and data processing  
*O. Dominguez*
- 21** Calibration of K and alpha for bulk commodities  
*R.C.A. Minnitt, D.K. Mukhopadhyay and L. Lautze*
- 35** Proactive Rolling Bias Test applied on Sample Stations  
*D. Johnson, J. Kelly and O. Dominguez*
- 41** Applications of the Sampling Uncertainty (SU)  
*B. Svensmark*
- 47** Process optimization by real time analysis of liquids’ composition in Metal & Mining  
*F. Maggiore et al.*
- 55** Monitoring the lot mean and uncertainty estimates by piecewise local modelling  
*P. Minkkinen*
- 65** Challenges in Quality Assurance and Quality Control Systems Development  
*N. Sukha*
- 79** Economic benefits of improving precision  
*T. Bruce and M. Hidding*
- 91** Implementing proactive Quality Assurance Quality Control and Quality Management practices at Coal Testing Laboratories  
*J. Kelly and O. Dominguez*
- 99** Differentiating Analytical Error from Sampling Errors in PAT Methods through Variographic Analysis  
*J. Puche et al.*
- 111** Comminution sizes in sampling calculations  
*D. Francois-Bongarcon and R. Oliver*
- 115** The sampling interface—A critical Theory of Sampling success factor in process sampling and PAT  
*K.H. Esbensen and V. Sivalingam*
- 131** Online elemental analysis for process control in the mineral processing industry  
*L. Rybok et al.*
- 139** Implementation of a QAQC program for in-situ grade control by Pulsed Fast and Thermal Neutron Activation methods  
*H. Reichardt et al.*
- 143** Process analytical technologies for precise, timely and representative measurement for conveyed flows  
*H. Kurth and L. Balzan*
- 151** Moisture determination. Mass loss on drying – Commercial sampling washed away  
*D.A. Vogel*
- 161** Case study - Improved sampling of iron sludge at Glencore Nikkelverk  
*E. Djuve and E.W. Thisted*
- 171** Choosing Metallurgical Samplers or Static Cutters for Process Control in Slurry  
*R. Novaes and M. Hidding*
- 177** Cross Belt Sampler: Mechanical Design of the World’s Largest Hammer Sampler for Bauxite Export Contractual Requirements  
*W.P. Slabbert*
- 193** Fake Data? The Need for Theory of Sampling Concepts in Environmental Research and Investigations  
*R. Brewer et al.*
- 207** Representative sampling for condition monitoring of in-service wind turbine bearings  
*H. Møller and K.H. Esbensen*
- 217** Experimental determination of the constitutional heterogeneity for sampling of Waste Printed Circuit Boards  
*S. Brochet et al.*
- 227** Sampling in a precious metals refining plant – A practical approach for a complex problem  
*B. Pauels*
- 239** Challenges of sampling grain for mycotoxin analysis  
*S.A. Tittlemier*
- 249** Estimation of uncertainty for measuring metals content in waste printed circuit boards  
*A. Hubau et al.*
- 255** Sampling of high-nugget conglomerates from the Western Australian Pilbara  
*S.C. Dominy, A. van Roij and J.C. Graham*
- 279** Mobile dust sampling device for dust filter generation at a Ni refinery  
*O. Bøckman and H. Indresand*
- 285** The evolution of the mechanically agitated hopper in Anglo American Platinum  
*N. Sukha, C. Kruger and N. Kobe*
- 291** Sampling for Industry 4.0 – Sensor signal acquisition inspired by the Theory of Sampling (TOS)  
*M. Lischka and K. Berelsmann*
- 303** The Ongoing Challenge of Representative Sampling of Bulk Mineral Commodities  
*R.J. Holmes*



- 313** Understanding sampling variation—a vital aspect of industrial research experiments  
*K. Engström, R. Jolsterå and P. Alanärä Lassi*
- 325** A comparison between conventional blast hole sampling and diamond core drilling  
*F. Toconas, L.S. Jordan and S. Kedda*
- 339** Case studies using Visman and Ingamells sampling approaches  
*F.F. Pitard*
- 353** ISO 13909 compliant contractual payment station coal sampling plant  
*M. Nyokong and W.P. Slabbert*
- 363** The state of organized sampling work for minerals in China since WCSB9  
*H. Li, S. Tang and L. Kuai*
- 375** Sampling for resource evaluation and grade control in an underground gold operation: a case of compromise  
*S.C. Dominy, H.J. Glass and S. Purevgerel*
- 397** The sampling and phase characterisation of black mass  
*L. Donnelly et al.*
- 411** Multivariate methods for improved geometallurgy sampling  
*Q. Dehaine and K.H. Esbensen*
- 419** Framing TOS in risk assessment: an outreach perspective for the future  
*C. Paoletti and K.H. Esbensen*
- 425** Gy's Discrete Heterogeneity and the Grouping and Segregation Variance  
*G.J. Lyman*
- 439** The process of production verified reference materials for silicon industry  
*J. Anyszkiewicz et al.*
- 440** Estimating the heterogeneity invariant using size-density classes  
*J.-S. Dubé and K.H. Esbensen*
- 441** Smart control of HVAC based on measurements of indoor radon concentration  
*M. Fromreide and I. Henne*
- 442** X-ray computed tomography for characterization of particulate materials heterogeneity  
*C. Robben, A. Moslemiyekan and K. Esbensen*
- 443** The “Gandalf” soil sampling project at a former industrial site  
*B. Svensmark et al.*
- 444** Sample preparation according to Ian Devereux: an unofficial guide  
*S. Russell*
- 445** COVID-19: Lessons for developing and commissioning new mining technologies  
*S. Russell*
- 446** ISO 8685 compliant contractual ship-loading export facility  
*W. Slabbert and M. Nyokong*
- 457** Applications of the Sampling Uncertainty  
*B. Svensmark*
- 458** The extended Gy's formula  
*B. Svensmark*
- 459** Representative sampling for food and feed materials  
*K.H. Esbensen, C. Paoletti and N. Thiex*
- 460** DS3077—Horizontal Standard revision after 10 years and induction as an ISO Standard  
*K.H. Esbensen and L. Skerning*

**A**

Alanära Lassi, P. 313  
Anyszkiewicz, J. 439

**B**

Böckman, O. 279  
Bachmann, C. 131  
Balzan, L. 143  
Berelsmann, K. 291  
Blandhol, K. 439  
Brewer, R. 193  
Brochot, S. 217, 249  
Bruce, T. 79  
Butcher, A.R. 397

**C**

Christensen, J.H. 443  
Corfe, I.J. 397

**D**

Dehaine, Q. 411  
Djuve, E. 161  
Dominguez, O. 11, 35, 91, 139  
Dominy, S.C. 255, 375  
Donnelly, L. 397  
Dubé, J.-S. 440

**E**

Eide, G. 439  
Eivindson, T. 47  
Engström, K. 313, 442  
Esbensen, K.H. 115, 207, 411, 419, 440, 459, 460

**F**

Francois-Bongarcon, D. 7, 111  
Fromreide, M. 441

**G**

Gengatharan, V. 439  
Glass, H.J. 375  
Gorewoda, T. 439  
Graham, J.C. 255  
Grant, A. 139  
Guldhav, A.Y. 439

**H**

Habau, A. 249  
Henne, I. 441  
Heskett, M. 193  
Hidding, M. 79, 171  
Holmes, R.J. 303  
Hubau, A. 217

**I**

Indresand, H. 279

**J**

Jamroz, E. 439  
Johnson, D. 35  
Jolsterå, R. 313  
Jordan, L.S. 325

**K**

Kedda, S. 325  
Kelly, J. 35, 91  
Kobe, N. 285  
Kostrzewa, J. 439  
Koushan, S. 139  
Kowoll, T. 131  
Kruger, C. 285  
Kuai, L. 363  
Kurth, H. 143  
Kuva, J. 397

**L**

Lahaye, Y. 397  
Lautze, L. 21  
Li, H. 363  
Lischka, M. 291  
Liu, X. 397  
Lukkari, S. 397  
Lyman, G.J. 425

**M**

Méndez, R. 99  
Møller, H. 207  
Maggiore, F. 47  
Milosevic, N. 443  
Minkkinen, P. 55  
Minnitt, R.C.A. 21  
Mortensen, P. 443  
Moslemiyekan, A. 442  
Mouris, A. 47  
Mukhopadhyay, D.K. 21

**N**

Nad, A. 131  
Novaes, R. 171  
Nyokong, M. 353, 446

**O**

Oliver, R. 111

**P**

Paoletti, C. 419, 459  
Pauels, B. 227  
Petrovic, S. 139  
Pirrie, D. 397  
Pitard, F.F. 1, 339  
Power, M. 397  
Puche, J. 99  
Purevgerel, S. 375

**R**

Ramsey, C. 193  
Reichardt, H. 139  
Robben, C. 442  
Romañach, R.J. 99  
Russell, S. 444, 445  
Rybok, L. 131

**S**

Sivalingam, V. 115  
Skerning, L. 460  
Slabbert, W.P. 177, 353, 446  
Song, J. 193  
Storesund, A. 439  
Sukha, N. 65, 285  
Svensmark, B. 41, 443, 457, 458

**T**

Tang, S. 363  
Teisrud, H. 439  
Thiex, N. 459  
Thisted, E.W. 47, 161  
Thomas, A. 131  
Tittlemier, S.A. 239  
Toconas, F. 325  
Touzé, S. 217, 249  
Toverø, A. 439

**V**

van Rooij, A. 255  
Vega, N.S. 99  
Vogel, D.A. 151

**W**

Wavrer, P. 217, 249

**Acknowledgement of Reviewers for WCSB10 Proceedings**

The following people gave their valuable time to review the over fifty abstracts and papers sent in for consideration. Their efforts and dedication to the Theory and Practice of Sampling is greatly appreciated. Thank you.

Roger Brewer  
Stephane Brochot  
Trevor Bruce  
Quentin Dehaine  
Oscar Dominguez  
Simon Dominy  
Karin Engström  
Kim H. Esbensen  
Dominique François-Bongarçon

Ralph Holmes  
Dr. Li Huachang  
Martin Lischka  
Pentti Minkkinen  
Richard Minnitt  
Claudia Paoletti  
Bert Pauels  
Francis F. Pitard  
Aldwin Vogel

<b>TECHNICAL PROGRAM WCSB10</b>	
<b>Tuesday, May 31 OPENING SESSION</b>	
<b>Caledonien Hall</b>	
08:15-08:30 Opening Ceremony /Updates	
<b>Session 1: TOS/QC/QA/QM 08:30-10:00</b>	
<b>Caledonien Hall</b>	
08:30 KEYNOTE: Francis F. Pitard, <b>The complex futility of the Liberation Factor</b>	
09:00 KEYNOTE: Dominique François-Bongarçon, <b>Liberation Factor for ‘closely sieved’ material</b>	
09:30 TECHNICAL: Oscar Dominguez, <b>Theory of Sampling (TOS) &amp; Quality Assurance Quality Control (QAQC) enabling the application and expectations of new technology and data processing</b>	
<b>10:00-10:30 COFFEE BREAK (outside Caledonian Hall) &amp; POSTER SESSION (Blomsterhaven)</b>	
<b>Session 2: TOS/QC/QA/QM 10:30-12:00</b>	
<b>Caledonien Hall</b>	
10:30 KEYNOTE: Richard Minnitt, <b>Calibration of K and Alpha for bulk commodities and precious metal ores</b>	
11:00 Daniel Johnson et.al., <b>Proactive rolling bias test applied on sample stations</b>	
11:20 Bo Svensmark, <b>Applications of the Sampling Uncertainty (SU)</b>	
11:40 Fabio Maggiore et al., <b>Process optimization by real time analysis of liquids’ composition in metal and mining</b>	
<b>12:00 -13:00 LUNCH</b>	
<b>Grenseløs Restaurant</b>	
<b>SESSION 3: TOS/QC/QA/QM 13:30-17:00</b>	
<b>Caledonien Hall</b>	
<b>Session 3A: 13:30-14:45</b>	
13:30 KEYNOTE: Pentti Minkkinen, <b>Monitoring the lot mean uncertainty estimates</b>	
14:00 Neressa Sukha: <b>Challenges in quality assurance and quality control system development</b>	
14:20 Trevor Bruce & B. Michael Hidding, <b>Economic benefits of improving precision</b>	
<b>14:45- 15:15 COFFEE BREAK (outside Caledonian Hall) &amp; POSTER SESSION (Blomsterhaven)</b>	
<b>Session 3B: 15:15 – 16:20</b>	
15:15 John Kelly & Oscar Dominguez, <b>Implementing proactive Quality Assurance Quality Control (QAQC) &amp; Quality Management (QM) practices at coal testing laboratories</b>	
15:35 TECHNICAL: Rodolfo Romanach et al., <b>Differentiating analytical error from sampling errors in PAT methods through variographic analysis</b>	
16:00 Dominique François-Bongarçon, <b>Comminution sizes in sampling calculations</b>	
<b>16:30-17:00 POSTER SESSION</b>	
<b>Blomsterhaven</b>	
<b>18:00 - RECEPTION</b>	
<b>SKY BAR</b>	

<b>Wednesday, June 1, MORNING SESSION</b>	<b>Caledonien Hall</b>
08:15-08:30 Program Updates	
<b>Session 4: Process Analytical Sampling (PAT) 08:30-10:00</b>	<b>Caledonien Hall</b>
08:30 KEYNOTE: Kim H. Esbensen, <b>The Sampling Interface—a critical success factor in process sampling and PAT</b>	
09:00 Lukas Rybok et al., <b>Online elemental analysis for process control in the mineral processing industry</b>	
09:20 Henning Reichardt, et al., <b>Implementation of a QAQC programme for in-situ grade control by Pulsed Fast and Thermal Neutron Activation methods</b>	
09:40 Henry Kurth & L. Balzan, <b>Process analytical technologies for precise, timely and representative elemental and moisture measurement for conveyed flows</b>	
<b>10:00-10:30 COFFEE BREAK (outside Caledonian Hall) &amp; POSTER SESSION (Blomsterhaven)</b>	
<b>Session 5: Mining /Minerals/ Metals 10:30-12:00</b>	<b>Caledonien Hall</b>
10:30 D. Aldwin Vogel, <b>Moisture Determination. Mass loss on drying—Commercial sampling washed away</b>	
10:50 Eirik Djuve & Elke Willam Thisted, <b>Case Study--Improved sampling of iron sludge at Glencore Nikkelverk</b>	
11:10 Reinaldo Novaes & Michael Hidding, <b>Choosing metallurgical samplers or static cutters for process control in slurry: when or why to avoid the increment delimitation error</b>	
11:30 Willem P. Slabbert, <b>Cross belt sampler: Mechanical design of the world’s largest hammer sampler for bauxite export contractual requirements</b>	
<b>12:00-13:30 LUNCH</b>	<b>Grenseløs Restaurant</b>
<b>SESSION 6: Sampling for Environment / Sustainability /Circular Economy 13:30-17:00</b>	<b>Caledonien Hall</b>
<b>Session 6A: 13:30-14:45</b>	
13:30 TECHNICAL: Roger Brewer et.al., <b>Fake Data? The need for sampling theory in environmental research and investigations</b>	
13:55 Hans Møller & Kim H. Esbensen, <b>Representative Sampling for condition monitoring of in-service wind turbine bearings: Challenges and solutions over 10 years</b>	
14:15 TECHNICAL: Stéphane Brochot et al., <b>Experimental determination of the constitutional heterogeneity for sampling waste printed circuit boards</b>	
<b>14:45-15:15 COFFEE BREAK (outside Caledonian Hall) &amp; POSTER SESSION (Blomsterhaven)</b>	
<b>Session 6B: Sampling for Environment / Sustainability /Circular Economy 15:15 – 16:20</b>	
15:15 TECHNICAL: Bert Pauels, <b>Sampling in a precious metals refining plant—A practical approach for a complex problem</b>	
15:40 Sheryl A. Tittlemier, <b>Challenges of sampling grain for mycotoxin analysis</b>	
16:00 Agathe Hubau et al., <b>Estimation of uncertainty for measuring metals content in waste printed circuit boards</b>	
<b>16:20-17:00 POSTER SESSION</b>	<b>Blomsterhaven</b>
<b>19:30 - GALA DINNER &amp; PIERRE GY GOLD MEDAL CEREMONY</b>	<b>Mannskapsmessa, Odderøya</b>

<b>Thursday, June 2 MORNING SESSION</b>		<b>Caledonien Hall</b>
08:15-08:30 PROGRAM UPDATES		
<b>Session 7: Mining /Minerals / Metals 08:30-10:05</b>		<b>Caledonien Hall</b>
08:30 KEYNOTE: Simon C. Dominy, <b>Sampling of high-nugget conglomerates from Western Australian Pilbara: Bulk sampling at Beatons Creek gold project, Nullagine</b>		
09:00 Oluf Bøckman & Hege Indresand, <b>Mobile dust sampling device for dust filter generation at a Ni refinery</b>		
09:20 Neressa Sukha, et al., <b>The evolution of the mechanically agitated hopper in Anglo American Platinum</b>		
09:40 TECHNICAL: Martin Lischka, <b>Sampling for Industry 4.0</b>		
<b>10:05-10:30 COFFEE BREAK (Outside Caledonian Hall) &amp; POSTER SESSION (Blomsterhaven)</b>		
<b>Session 8: Mining/ Minerals / Metals 10:30-12:20</b>		<b>Caledonien Hall</b>
10:30 KEYNOTE: Ralph Holmes, <b>Ongoing challenges of representative sampling of bulk mineral commodities</b>		
11:00 Karin Engström et al., <b>Understanding sampling variation—a vital aspect of industrial research experiments</b>		
11:20 Felix Tocanas et al., <b>A comparison between conventional blasthole sampling and diamond core drilling for copper grade at the Antapaccay mine</b>		
11:40 Francis F. Pitard, <b>Case Studies using Visman &amp; Ingamells sampling approaches</b>		
12:00 Modisaotsile Nyokong & Willem Slabbert, <b>ISO 13909 compliant contractual payment station coal sampling plant: Process design and equipment selection for chemical, physical and moisture sampling</b>		
<b>12:20- 13:30 LUNCH</b>		<b>Grenseløs Restaurant</b>
<b>SESSION 9: Around the World New Developments/ Going Forward 13:30-15:20</b>		<b>Caledonien Hall</b>
13:30 KEYNOTE: Dr. Li Huachang, <b>The state of organized sampling work for minerals in China since WCSB9</b>		
14:00 Simon Dominy et. al., <b>Sampling for resource evaluation and grade control in an underground gold operation: a case of compromise</b>		
14:20 Laurance Donnelly, et al., <b>The sampling and phase characterisation of black mass</b>		
14:40 Quentin Dehaine & K.H. Esbensen, <b>Multivariate methods for improved geometallurgy sampling</b>		
15:00 TECHNICAL: Claudia Paoletti & K.H. Esbensen, <b>Framing TOS in risk assessment: A broader perspective for the future.</b>		
<b>15:30- 16:15</b>	<b>IPGSA General Assembly: Open to All</b>	<b>Caledonien Hall</b>
<b>16:15 -16:45</b>	<b>Council Meeting: Members Only</b>	<b>Baldwin Room</b>
<b>16:15-16:45</b>	<b>COFFEE BREAK</b>	
<b>16:45-17:00</b>	<b>Closing Ceremony; Next Venue</b>	<b>Caledonien Hall</b>

WCSB10 POSTERS
J. Anszkiewicz, et al., <b>The process of production certified reference materials for silicon industry</b>
J. Dube and K.H. Esbensen, <b>Estimating the heterogeneity invariant using size-density classes—the case of contaminated soil and complex materials</b>
M. Fromreide and I. Henne, <b>Smart control of HVAC based on measurements of indoor radon concentration</b>
C. Robben, et al., <b>X-Ray Tomography (XCT) for characterisation of particulate materials heterogeneity: Embrace heterogeneity—create value with separation and sorting</b>
S. Russell, <b>Sample preparation according to Ian Devereux: an unofficial guide</b>
S. Russell, <b>Covid 19: Lessons for developing and commissioning new mining technologies</b>
W. Slabbert and M. Nyokong, <b>ISO8685 Compliant contractual ship loading export</b>
B. Svensmark, <b>Applications of Sampling Uncertainty (SU)</b>
B. Svensmark, <b>The extended Gy's formula</b>
B. Svensmark, <b>The Gandalf soil sampling project at former industrial site in Copenhagen, Denmark: Evaluating soil classification reliability</b>
K.H. Esbensen, et al., <b>Representative sampling of food and feed materials: A critical need for food/feed safety</b>
K. H. Esbensen and L. Skerning, <b>DS3077—Horizontal Standard revision after 10 years and induction as an ISO Standard</b>

## The complex futility of the Liberation Factor

F. F. Pitard<sup>a</sup>

Francis Pitard Sampling Consultants, LLC, 14800 Tejon Street, Broomfield, Colorado, 80023, USA (E-mail: [fpssc@aol.com](mailto:fpssc@aol.com))

Prior to 1957 Dr. Pierre Gy knew two objectives needed to be addressed to optimize the sample mass with respect to well defined Data Quality Objectives; these two objectives were: First, determine the appropriate sample mass to represent all fragments size fractions present in the lot to be sampled, being perfectly aware that the size fraction most difficult to sample was the size fraction made of the largest fragments. The logic was that the content of the constituent of interest changes from one size fraction to the next. Second, determine the appropriate sample mass to represent the largest particles of a given constituent of interest in a specific state of comminution. Basically, someone had to make the calculation twice and select the worst outcome as the necessary sample mass.

To overcome this difficulty and provide a valid formula for both cases, Dr. Pierre Gy created his famous formula accounting for the size of the largest fragments and taking care of the size of the largest particles of the mineral of interest by introducing the concept of the liberation factor for a given state of comminution. This was at the time a huge academic achievement. However, it is well known that over the years this formula and the determination of the liberation factor led to arguments, controversy, and vast misuse from sampling practitioners. That new revolutionary approach that was suggested by Dr. Pierre Gy turns out to be too complicated for sampling practitioners to resolve their sampling problems effectively, and not be the target of unfair criticism.

This paper suggests a wise return to the old strategy making the calculations twice and determine what is the worst scenario to determine the necessary sample mass. The approach is simple, with no necessary determination of a liberation factor, and unlikely to lead to errors due to the inherent complexity of Dr. Pierre Gy's famous formula.

### Introduction

The complete formula suggested by Dr. Pierre Gy is summarized under the following well known form:

$$s_{FSE}^2 = \left( \frac{1}{M_S} - \frac{1}{M_L} \right) IH_L \quad [1]$$

$M_S$  is the mass of a sample to be collected.  $M_L$  is the mass of the Lot where the sample is collected from.  $IH_L$  is the Intrinsic Heterogeneity of the Lot to be sampled. It is demonstrated that  $IH_L$  is the product of five factors:

$$IH_L = fgc\ell d^3 \quad [2]$$

$f$  is a fragment shape factor.  $g$  is a particle size distribution factor taking into account that all fragments are not necessarily the same size as the coarsest fragment.  $c$  is a mineralogical factor taking into account the density of the constituent of interest and its expected average content in the Lot.  $\ell$  a liberation factor taking into account that the constituent of interest is not free from the gangue for a given state of comminution.  $d$  at third power is the size of the coarsest fragments defined as the opening of a screen retaining no more than 5% of the material to be sampled.

The approximate estimation of the liberation factor  $\ell$  is mathematically derived under the following, final form:

$$\ell = \frac{a_{\max} - a_L}{1 - a_L} \quad [3]$$

$a_L$  is the expected content of the constituent of interest.  $a_{\max}$  is the expected maximum content of the constituent of interest among the coarsest fragments in the top size fraction of the material to be sampled.

It should be clearly understood that equation [3] is the only valid equation to properly estimate what the value of the liberation factor is. Any other empirical formula such as the one shown in equation [4] is not a valid form to include in equations [1] and [2].

$$\ell = \left( \frac{d_\ell}{d} \right)^r \quad [4]$$

In equation [4]  $d_\ell$  is the size below which at least 95% of the material must be crushed to liberate at least 85% of the mineral of interest: it is defined as the liberation size. The value of  $r$  is to be estimated by performing empirical experiments.

Because equation [4] is strictly empirical, it would be a great mistake to introduce it in equations [1] and [2]. The reason is simple: it would completely destroy the capability of equations [1] and [2] to account properly for the coarse size fraction in any collected sample, which would lead to an unacceptable flaw.



## Learning to live with three Cardinal Rules

The following Cardinal Rules are a necessity to estimate the appropriate mass of samples to satisfy any given Data Quality Objective; therefore, they are not negotiable.

### Cardinal Rule #1 in Sampling

Biases in sampling are the worse misfortune that may take place, and they were the driving force to establish the many rules of sampling correctness, so theoretical developments of equi-probable sampling made by Gy and Matheron could apply in practice. This led to the many advances to minimize Increment Delimitation Error, Increment Extraction Error, Increment Preparation Errors and Increment Weighting Error which are the biggest contribution of Gy's theory by far according to his own words. Is this sufficient to prevent sampling biases? The answer is no. For example, it is well known that the content of a constituent of interest may drastically change from one size fraction to another. Then, plain logic would suggest the following *Cardinal Rule* in sampling should never be broken: **a sample mass that is too small to well represent all size fractions cannot provide a sample representative of anything else**; this has huge implications for any kind of Heterogeneity Test.

Successive stages of sampling and sub-sampling may each require compliance with a pre-established limit that highly depends on the practitioner's objectives<sup>1</sup>. The most difficult size fraction to properly represent in the sample is obviously the one containing the largest fragments. This strongly suggests the following Gy's formula to calculate the variance of the Fundamental Sampling Error to be used to make sure a given size fraction is well represented in collected samples:

$$s_{FSE}^2 = \left[ \frac{1}{M_S} - \frac{1}{M_L} \right] f \cdot \rho \left[ \left( \frac{1}{a_{Lc}} - 2 \right) d_{FLc}^3 + \sum_x d_{FLx}^3 \cdot a_{Lx} \right] \quad [5]$$

$d_{FLc}$  is the size fraction of interest,  $a_{Lc}$  is the expected proportion of the size fraction of interest in the lot  $L$ ,  $\rho$  is the density of the fragments to be sampled,  $d_{FLx}$  is each size fraction other than the one of interest,  $a_{Lx}$  is the expected proportion of each size fraction other than the one of interest.

This formula can often be simplified for many applications:

- If  $M_L > 10M_S$
- If  $d_{FLc}$  is not much different from  $d$  defined as the size opening of a screen that would retain 5% of the material by weight.
- If  $a_{Lc}$  is small, then

$$s_{FSE}^2 = \frac{f \cdot \rho}{M_S} \left[ \frac{1}{a_{Lc}} - 2 \right] d_{FLc}^3 \quad [6]$$

and if  $d_{FLc} = d$ , so we can make sure the most difficult size fraction is well represented in the sample, with  $a_{Lc} = 0.05$  by definition, we obtain:

$$s_{FSE}^2 = \frac{18 \cdot f \cdot \rho \cdot d^3}{M_S} \quad [7]$$

This convenient formula provides a filter to make sure the exponent  $x$  for  $d$  is not abused when used in a formula like the following one:

$$s_{QFE1}^2 = \left[ \frac{1}{M_S} - \frac{1}{M_L} \right] K \cdot d^x \quad [8]$$

$$K = f \cdot g \cdot c \cdot (d_c)^r \quad \text{and} \quad x = 3 - r$$

$K$  and  $x$  are the key factors to quantify in various experiments. If  $x < 3$ , clearly it is not an issue when the values for  $d$  are below 1 cm, however it can indeed become an issue for large values of  $d$  such as for sampling runoff mine material or even blasthole piles.

*Example of application:* If a runoff mine material has a value of 10 cm for  $d$  and a 1-ton sample is required to represent the coarsest fragments with an uncertainty of 15% (1s), it would be unfortunate to recommend a much smaller mass on the basis that  $x$  is much smaller than 3. Obviously, the value used for  $K$  has a big influence on the outcome of this discussion; indeed, if  $K$  is very high it is likely that there is no problem; the point is: be very cautious about this issue.

## Cardinal Rule #2 in Sampling

The size  $d_M$  of the grains of the constituent of interest, liberated or not, must play an important role in the necessary sample mass.  $d_M$  can also be a cluster equivalent when several of those grains are very close to one another within a core sample or within a large fragment. Gy corrected for this problem in an elegant way, not always well understood by practitioners, with his liberation factor. In other words, in his original formula with  $x = 3$ , both concepts  $d$  and  $d_M$  were preserved; be aware it is no longer the case with empirical formula [8].

Often, especially for trace constituents, it is difficult and impractical to determine the liberation factor with sufficient accuracy, and this makes some formulas vulnerable. Enormous literature has been written on this subject, the best one by François-Bongarçon<sup>2,3</sup>. However, it is not a must to use the conventional, favorite approach suggested by Gy's general and well-known formula. The following suggestion is pragmatic, accurate, and falls in line with Ingamells' approach; it is summarized in the three following statements:

- Use Gy's suggested approach for liberated gold when  $d_M$ , which is  $d_{Au}$  in formula [9], becomes the dominant factor; it can be generalized to many other components of interest:

$$S_{FSE}^2 = \left[ \frac{1}{M_S} - \frac{1}{M_L} \right] \frac{f_{Au} \cdot g_{Au} \cdot \rho_{Au} \cdot d_{Au}^3}{a_L} \quad [9]$$

- Verify that the sample mass suggested by the generalized version of equation [8] is compatible with the mass necessary to represent **all size fractions** in the lot by using equation [7].
- The largest required sample mass for a pre-selected precision, obtained by equation [7] (i.e., using  $d$ ) and equation [9] (i.e., using  $d_{Au}$ ) necessarily takes priority on deciding what the sample mass in the sampling protocol should be.

Generalization of equation [9] by defining new notations:  $f_M$  the shape factor of the constituent of interest,  $g_M$  the particle size distribution factor of the constituent of interest,  $\rho_M$  the density of the constituent of interest,  $d_M$  the maximum size of the constituent of interest particle, liberated or not, or cluster of such particles contained in a single fragment of the surrounding matrix;  $d_M$  is defined as the size of a screen that would retain no more than 5% by weight of all the particles of the constituent of interest.

Thus, we obtain the very useful simplified formula:

$$IH_L = f_M \cdot g_M \cdot d_M^3 \cdot \frac{\rho_M}{a_L} \quad [10]$$

Useful sampling nomographs can be calculated with the following formula:

$$S_{FSE}^2 = \left[ \frac{1}{M_S} - \frac{1}{M_L} \right] \frac{f_M \cdot g_M \cdot \rho_M \cdot d_M^3}{a_L} \quad [11]$$

The great advantage of this approach is its accuracy and the easiness to collect the relevant and necessary information through microscopic observations, and it should somewhat reconcile Gy, Ingamells, and François-Bongarçon. In the event reconciliation is not possible it should be a clear indication some heterogeneity properties of the constituent of interest are still unknown and further investigation is needed. This debate naturally leads to Cardinal Rule #3.

Another advantage of equation [11] is for subsampling finely ground material, as some constituents such as soft ones like gold, molybdenite, galena and many more do not comminute well. Very hard minerals like chromite may show the same problem. For example, a sample pulverized to 99% minus 106 microns may still contain a 300-micron gold particle making all other formulas weak and perhaps misleading.

As Pierre Gy said many times, especially when criticizing the work of Richard (1908), when deciding what the exponent of  $d$  should be, and therefore the constant  $x$ , there is a confusion between  $FSE$ ,  $QFE_1$ , and even the Analytical Error  $AE$  poorly defined by non-chemists and TOS experts. This confusion has been responsible for over a century for total chaos and remains an issue today. Problems are:

1. For very fine material the variance of  $FSE$  rapidly becomes a negligible factor unless unrecognized delayed comminution takes place for the constituent of interest.
2. The segregation error can be huge as the constituent of interest is liberated and possibly of a very different density than the rest of the material.
3. Taking the optimistic assumption that analytical increments are taken perfectly at random (**an absolute requisite for Gy's definition of GSE**), which is rarely the case at the balance room of a laboratory, the variance of  $GSE$  can become small indeed and not larger than the variance of  $FSE$ ; however, it takes work, and an analytical chemist is not willing to spend the necessary time to perform the task correctly. As a result, the segregation error, which is no longer  $GSE$  but some unknown entity depending on operators, may become vastly underestimated because it no longer obeys rules of sampling correctness set by the TOS.
4. The variance of the Analytical Error  $AE$  cannot be estimated by performing replicate assays that include the last  $FSE$  and last  $GSE$  or some other entities depending on operators. Let's assume the chemist takes a 30-g analytical

subsample for fire assay; the taking of that sample has nothing to do with the Analytical Error which includes fusion, cupellation, acid digestion of a bead, contamination, losses, spectrometer calibration or use of a precision balance, additive and proportional interferences, etc... In other words, it is very hard, if not impossible in some cases to appreciate what the variance of *AE* really is. Furthermore, *AE* is extremely operator dependent. There is no such thing as a bad analytical method, there are only incompetent analysts who apply it for the wrong conditions.

5. There is no such thing as a segregation free analysis when taking replicate samples in a given size fraction as particles segregate even if they are all the same size. They will most certainly segregate because of density, shape, electrostatic property differences, etc...

All this was clearly familiar to Visman, Ingamells and Gy through verbal conversations, and many others who were wise enough to admit that what they measured with replicate samples or replicate assays may have nothing to do with the variance of *FSE*. When segregation is mentioned, it is not necessarily referring to the Grouping and Segregation Error *GSE* but instead to the short-term Quality Fluctuation Error *QFE*, combined with some elusive and residual components of *IDE*, *IEE*, *IPE*, and the Analytical Error *AE*. The subtle difference depends on what the operator may do. So, this strongly suggests variance sources should be called by their respective name instead of calibrating *x* in equation [8] to compensate for things that are not clearly defined or understood.

An example is appropriate: an operator shakes a laboratory pulp to collect a tiny analytical sample, then makes the assumption there is no longer any significant segregation in the pulp, and finally takes one or two tiny increments with no respect to the TOS. The resulting variance, after guessing what the analytical variance should be and removing it, is found to be large. The operator put the blame on a large variance of *FSE* when it is clear that he was introducing a massive segregation variance because of the way he collected the increments. He was introducing a variance that has nothing to do with *FSE*, nor *GSE*, because all the subtle principles clearly defined in TOS were completely ignored, therefore prohibit the segregation variance to be a random one as it should be.

### Cardinal Rule #3 in Sampling

The following integrated, iterative approach to estimate the variance of *FSE*, or *FSE* + *GSE*, should be made a cardinal rule in sampling. Iteration is the word of wisdom in sampling. The following steps are not necessarily suggested in chronological order. Rather, each step can be taken simultaneously which ultimately will provide confidence that no stone has been left unturned.

#### *The mandatory calibration of K and x*

The calibration of constants *K* and *x* in equation 8 as suggested by François-Bongarçon is a mandatory step that is non-negotiable; please notice notations in that formula very carefully. Indeed, the use of the notation *QFE*<sub>1</sub> is valid only if the operator has collected many increments in full compliance with sampling correctness, which is a very optimistic assumption as experience proves. If not in full compliance, then the resulting variance is anyone's guess because there is no longer any theoretical development possible as demonstrated by Gy and Matheron. Such calibration allows us to minimize the variance of the Fundamental Sampling Error and also measures the leftover effect of the Grouping and Segregation Error depending on the equipment used to split samples at the sample preparation room and at the laboratory, and on the operator's training which can be a huge factor. For the details of such procedure the reader is referred to François-Bongarçon's publications <sup>2,3</sup>.

#### *The geologist to the rescue*

It is necessary to better log the properties of the constituent of interest in each geological unit. For each core sample within substantial mineralization the following information should be carefully logged, taking the example of gold:

- Where is the gold?
- What are the associations of gold?
- How much gold is finely disseminated within sulfides, such as pyrite or other minerals?
- How much gold is coarse and perhaps nearby other minerals?
- Are gold and pyrite or other mineral occurrences associated with narrow or large quartz veins? If so, are there several quartz events?
- Study size distribution of gold particles. A good histogram is needed for each geological unit. After observing several thousand samples within mineralization it should be possible to roughly estimate the size  $d_M$  above which only 5% of the gold can report.
- Equally important, study the size distribution of gold particle clusters; in other words when you see one gold particle (measure it), how many more gold particles are in the immediate vicinities? e.g., 10 or more within 100 cm<sup>3</sup>? After observing several thousand samples within mineralization it should be possible to roughly estimate the size  $d'_M$  above which only 5% of the gold can report as cluster equivalents.
- Etc...

#### *The mineralogist to the rescue*

Suarez and Carrasco<sup>4</sup> demonstrated in an unambiguous way that careful mineralogical studies can provide valuable information to model the variability of the liberation factor as a function of comminution stage. It is very unfortunate that such

study does not generate more interest. The same study suggests that the maximum content model suggested many years ago by Gy is a very reliable model that was used all the time in a mineral processing research laboratory (Minemet); see Gy<sup>5,6</sup> and Pitard<sup>1</sup>.

#### *Representing the coarsest fragments*

The selected sample or subsample mass must fairly represent the coarsest fragments. This task is easily done by using formula [5] or [7].

#### *Representing the coarsest particles of the constituent of interest*

The selected sample or subsample mass must fairly represent the largest particles of a given constituent of interest. This task is done by using formula [11]. This is critically important for constituents showing delayed comminution. Usually, soft minerals such as gold, galena, molybdenite and very hard minerals such as chromite can show such problem. As a good example, the coarse gold case shown by Pitard and Lyman<sup>7</sup> clearly shows that a Heterogeneity Test performed by using conventional 30-g fire assays would most likely have led to very misleading conclusions; the test is not the problem, but the completely inappropriate 30-g subsample is the issue, in other words the operators would have used the wrong tools.

#### *A logical flow sheet to perform Heterogeneity Tests*

Figure 1 summarizes the necessary steps to perform a reliable Heterogeneity Test for various constituents of interest during exploration and grade control; the approach can easily be extended to other materials in other industries. The reconciliation box has a very important mission in cases where conclusions are grossly different: a logical explanation must be found that may lead to important decisions concerning the selection of fully optimized sampling and subsampling protocols.

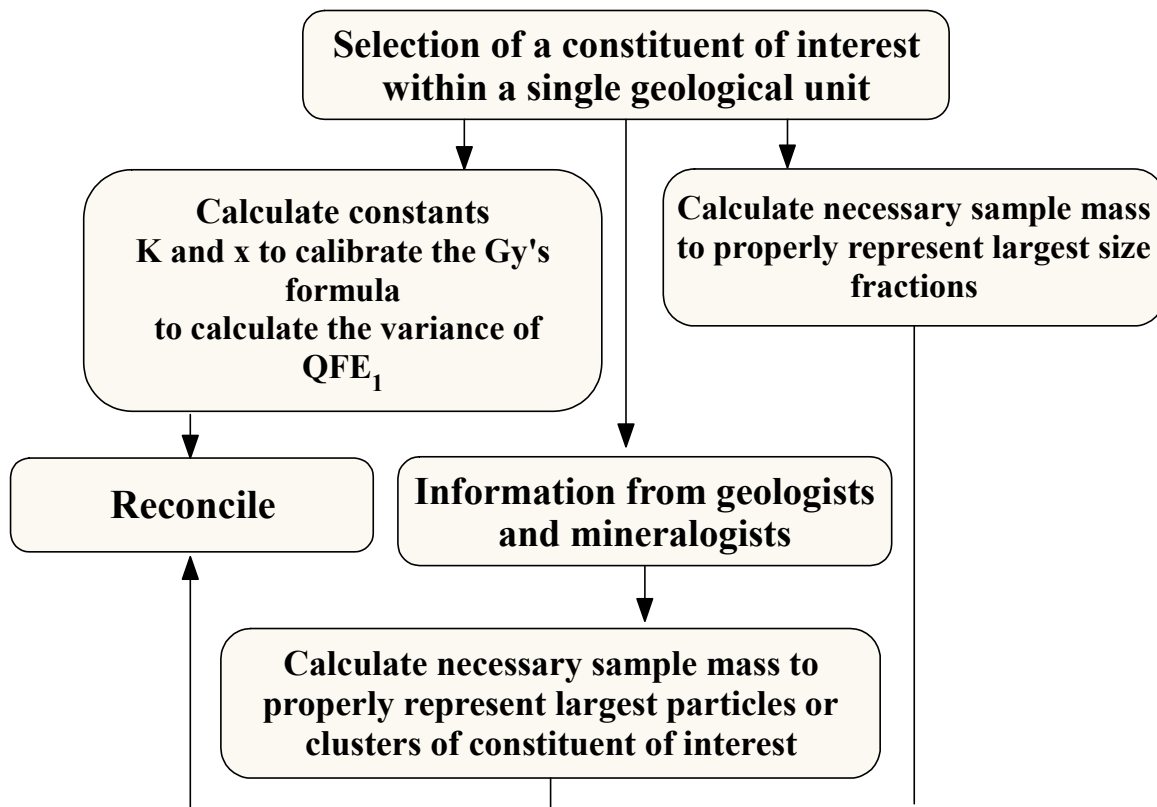

**Figure 1. Logical Heterogeneity Test flow sheet**

#### *Calculating the necessary sample weight $M_s$ instead of the variance of FSE*

To prevent any misunderstanding about possible Poisson processes introduced by using insufficient sample weight  $M_s$ , and create any issue about the validity of Gy's formulas, anyone can turn the formulas around and calculate the necessary sample weight that is required to prevent the introduction of a Poisson process, and remain in a domain for which the formulas are perfectly applicable. It is also a good practice to calculate the necessary sample weight in accordance with appropriate DQO guidelines<sup>1</sup>.

## Conclusion

When the world is full of sampling experts, we tend to accumulate too many unnecessary difficulties to make everyone relatively happy. This is the mission of WCSB, but the time has come to reflect and simplify the life of people struggling every day to optimize their sampling and subsampling protocols. Therefore, it is of the utmost importance for WCSB to provide a simple road map and this paper is a first attempt to come to a few appropriate recommendations:

Set Data Quality Objective in a logical way, with the approval of upper management.

1. Make sure the selected sample mass fairly represents all size fractions, and especially the coarsest size fraction that requires large sample mass.
2. Know the characteristics of the constituent of interest, and make sure the select sample mass fairly represents the coarsest grains of the constituent of interest.
3. Select the largest necessary sample mass from point 2 and 3, as the appropriate sample mass for a given stage of comminution.
4. Try to reconcile this approach with estimation of constant K and x estimated from other conventional approaches<sup>2,3</sup>.

It is likely that it will be impossible to reconcile when sampling material contain fragments larger than 1 cm, and the larger they are the more the divergence will take place.

It is also likely that it will be impossible to reconcile when sampling material containing large particles of the constituent of interest if that constituent is affected by delayed comminution. For example, a material containing molybdenite may be pulverized to 95% minus 106 microns and still contain two or three molybdenite particles larger than 500 microns.

At this stage the user trying to optimize a sampling protocol should be able to take a logical decision based on plain logic.

## References

- [1] **Pitard, F.F.** (2019). Sampling Theory and Sampling Practice. *Textbook published by CRC Press, Inc., 2000 Corporate Blvd., N.W. Boca Raton, Florida 33431.* Third edition, January 2019. Section 11.8 Important Guidelines.
- [2] **François-Bongarçon, D.** (2000). The most common error in applying Gy's formula in the Theory of Mineral Sampling, and the history of the liberation factor. *monograph "Toward 2000", AusIMM.*
- [3] **François-Bongarçon, D and Gy, P** (2001). The most common error in applying 'Gy's Formula' in the theory of mineral sampling and the history of the Liberation factor, *in Mineral Resource and Ore Reserve Estimation – The AusIMM Guide to Good Practice*, pp 67-72 (The Australasian Institute of Mining and Metallurgy: Melbourne).
- [4] **Suarez, E.V., and Carrasco P.,** Numerical studies of texture and liberation in microscopic images, Fifth World Conference on Sampling and Blending", 25-28 October 2011, Santiago, Chile. Proceedings printed by Gecamin.
- [5] **Gy, P.M.,** Poids a donner a un echantillon – abaques, Rev. Ind. Minerale, 38, 1956.
- [6] **Gy, P.M.,** Nomogramme d'échantillonnage – Probeahme Nomogram, Minerais et Metaux, Paris, 1956. German edition published by Gesellschaft Metallhütten und Bergleute.
- [7] **Pitard, F.F., Lyman, G.,** Single and multi-stage Poisson processes: a case study for gold exploration, World Conference on Sampling and Blending: WCSB6, Lima, Peru 2013. Proceedings published by Gecamin.

## Liberation factor for 'closely sieved' material

D. Francois-Bongarcon<sup>a</sup>

<sup>a</sup> AGORATEK International Consultants Inc. (AICI) E-mail: dfbgn2@gmail.com

**Closely sieved (a.k.a. calibrated) material, i.e. material obtained as retained between two screens, is commonly sampled. One example is some iron ores, when drill-hole samples are screened at multiple sizes and the size fractions are sampled in an attempt at predicting iron ore products that could be generated. Another, growing example is the heterogeneity testing method in which instead of crushing parts of a lot at different sizes to generate experimental series of samples, a single coarse crushing is used, then size fractions are obtained by screening and experimental series are generated from each one. Questions automatically then arise: How do we control the sampling variance when sampling calibrated material? And how can we use calibrated material in heterogeneity testing? Under deeper examination, the issue amounts to finding a model for the liberation factor of the calibrated material. A method was used to find a reasonable form for that model, to be customised, as in the general case of unsieved, crushed material, using heterogeneity testing.**

### Introduction

In the case of uncalibrated material, Gy established a numerical model (formula) to control the relative variance of the fundamental sampling error, as follows:

$$\text{Rel.Var.} = c\ell \text{fgd}_{95}^3 (1/M_s - 1/M_L) \quad (1)$$

in which the term  $\text{fgd}_{95}^3$  intends to represent the mass-weighted average fragment volume in the lot. It includes the chosen, nominal, 95% passing size  $d_{95}$ , a shape factor  $f$  that transforms the cube of that size into a volume, and the granulometric factor  $g$ , which pretends to transform the nominal volume  $fd_{95}^3$  into that mass-weighted average volume.

For calibrated material, i.e. sieved between two screens of sizes  $d_{\min}$  and  $d_{\max}$  (coined 'closely sieved material' by Gy to reflect the use of two successive screenings), he went further: he demonstrated (quite rigorously) an alternative granulometric factor  $g'(r)$  as a function of the ratio  $r=d_{\max}/d_{\min}$ <sup>1</sup>, to be substituted to constant  $g$  in formula (1) in such a case, applying it to  $d_{\max}^3$  instead of  $d_{95}^3$ . This nicely solved the problem of the term  $\text{fgd}_{95}^3$  in (1) but not the entire formula. Indeed, for that material, (1) would now write:

$$\text{Rel.Var.} = c\ell' \text{fg}'d_{\max}^3 (1/M_s - 1/M_L) \quad (2)$$

as the liberation factor  $\ell'$  clearly differs from that of the uncalibrated material of origin. To understand this, suffice it to think of two lots of the same material, crushed to two different coarse sizes, then both subjected to the same  $[d_{\min}, d_{\max}]$  pair of screens. This results in the same calibrated material in both cases, with the same liberation factor, although the two lots of origin indeed had different liberation factors following crushing.

It is important to realise that the 'volume' term,  $\text{fgd}_{95}^3$  in (1) or  $\text{fg}'d_{\max}^3$  in (2), address an issue that is independent from that of the liberation degree.

As a result, two questions arise:

- How do we control the sampling variance when sampling calibrated material?
- How can we use calibrated material in heterogeneity testing?

Both amount to the problem of finding a reasonable and inferable model for  $\ell'$ .

### Heterogeneity testing

Recent developments have demonstrated that the method of the sieves was very effective for heterogeneity testing and is now slowly replacing the other method ('sample tree'). To implement it in practice, a lot of very coarsely crushed material is sieved into a number of size fractions and each size fractions is split (usually with a riffle splitter) to generate a series of samples. The primary sampling relative variance in each series, divided by  $c\text{fg}'(1/M_s - 1/M_L)$  is then equated to  $[\ell' d_{\max}^3]$  in equation (2) to calibrate a model for  $\ell'$ .

In the case of uncalibrated material, by comparison, the modified variance is equated to  $\ell d_{95}^3$  and a model is used for  $\ell$ , e.g.  $\ell = (d_i/d_{95})^{3-\alpha}$ , so that the quantity to calibrate in  $d_i$  and  $\alpha$  really is:

$$(d_i/d_{95})^{3-\alpha} d_{95}^3 \quad (3)$$

This expression, when plotted on a log-log scale for nominal sizes  $d_{95}$  at or above  $d_i$  gives a straight line of slope  $\alpha$  and intercept  $\log(d_i^{3-\alpha})$ .

In the heterogeneity test using sieves, one is often lead to mixing sample series taken from calibrated material and

sample series from uncalibrated material (usually the finest series, consisting of the under-size of the smallest screen, as well as a series of pulverized material). Since the test consists in the calibration of the parameters influencing the liberation factor, those two types of series - which are deemed to correspond to different liberation factor models - cannot be posted on the same calibration graph without some proper modifications to account for it formally. These modifications would, at the same time, automatically suggest the form of a reasonable model for the liberation factor  $\ell'$  of closely sieved material.

### Model of liberation factor for calibrated material

On the calibration log-log graph (i.e. modified relative variance vs. fragment size), the points for calibrated material series would have to be posted for their respective d-max sizes. The first step therefore consists of rewriting formula (1) for uncalibrated material (now regarded as a special case of calibrated material, only with a small value of  $g'(r)$  corresponding to a very large value of ratio  $r$ ), to make  $g'$  and d-max appear. Remembering the introduction of  $g'$ <sup>1</sup>:

$$gd_{95}^3 = g'(r) d\text{-max}^3 \quad (4)$$

we get:

$$\text{Rel.Var.} = c\ell' fg'd\text{-max}^3 (1/M_s - 1/M_L)$$

with  $\ell' = \ell$  as the liberation factor has not changed. So to elicit the desirable analytical form of a compatible model for  $\ell'$ , all we need to do is transform our model  $\ell' = \ell = (d_r/d_{95})^{3-\alpha}$  using (4) to express it as a function of  $g'$  and d-max only:

$$\ell' = [(g/g')^{1/3} d_r / d\text{-max}]^{3-\alpha} \quad (5)$$

In this expression, of course,  $d_{95}$  has become irrelevant and has disappeared and  $g$  is equal to 0.25, while  $g'(r)$ , for any given lot of closely sieved material, is given by the following equations<sup>1</sup>:

$$r = d\text{-max}/d\text{-min}$$

$$R = 3 \text{LN}(r) / \text{LN}(2)$$

$$g' = (1.5 - 1/2^{R-1} + 1/2^{R+1}) / R$$

Equation (5) is the propagation to  $\ell'$  of our classical model for  $\ell$ .

### The problems

But equation (5) show a serious methodology problem for heterogeneity testing: while the quantity to calibrate (3) when using only uncalibrated material depends only on  $d_{95}$  for each experimental point, the formula to be calibrated after proper modification of the primary variance (i.e.:  $[(g/g')^{1/3} d_r / d\text{-max}]^{3-\alpha} d\text{-max}^3$ ) depends not only on d-max, but also on ratio  $r$  through  $g'$ . This normally preclude such an exercise, as every point on the calibration graph, having a different  $g'$ , will correspond to a different formula. Unless of course in (3), we ensure a constant value of  $g'$  for all series, i.e. using screen with sizes in geometric progression. But even then, the question arises whether the model-fitting graph could rigorously accommodate both uncalibrated and calibrated material.

### The practice

Formulas (2) and (5) are all we need to reasonably control the variance of the FSE in calibrated material. In order to effectively do so, remains to perform heterogeneity testing to experimentally infer the parameters  $d_r$  and alpha in (5).

The proper use of calibrated material to this end prescribes the screens used should have sizes in geometric progression. This does not have to be very strictly done. The important is to make sure the d-max sizes used will be uniformly distributed in good approximation along the logarithmic X axis, which anyway would be highly desirable for a good inference of the linear model fitted to the corresponding experimental points. The screen sizes will then automatically be in an approximate and good enough geometric progression.

When this is done, the factor  $(g/g')^{1/3}$  in (5) will vary little, usually between 0.75 and 0.95 with an average close to 0.85. These small variations from series to series will only increase a little the general and normally expected scattering of the experimental data, while the fitted line will reflect the average value of that not rigorously constant factor. Of course the more accurate the geometric progression, the better. The model fitted to the graph above liberation size will be a straight line of slope alpha and intercept  $\log[(g/g')^{1/3} d_r]^{3-\alpha}$  at d-max = 1 unit.

In the older, sample-tree method, uncalibrated material was sampled at different  $d_{95}$  comminution nominal sizes. The line fitted above liberation size to the points reflected the model  $\ell = (d_r/d_{95})^{3-\alpha}$ . The fitting line had an intercept worth  $\log[d_r^{3-\alpha}]$  at  $d_{95} = 1$  unit, different from that of calibrated material by an additive term  $(1 - \alpha/3)\log(g/g')$ .

When adding experimental points from uncalibrated material sampling to a fitting graph showing points from calibrated material, these can be posted at their  $d_{95}$  sizes, after dividing the variance by  $g$  and other terms. The posting and fitting being interactive, it is not difficult then to multiply the posted variance by a factor equal to  $(g/g')^{1-\alpha/3}$  to ensure compatibility with the calibrated material. The value of  $g/g'$  is for the calibrated portion of the data, and this correction is important: If this step is omitted, on average, there will be an error factor in the order of magnitude of 23% on the variances posted

for the uncalibrated material, which may or may not be a problem for the final fitting result.

Indeed, these errors, and, more generally, the normal experimental data scattering in these calculations, are generally quite dampened by a good handling of a few outliers anyway. This handling is originally necessary to eliminate or lessen, as much as possible, impossible order relations between experimental variances: indeed, the 'real' curve to which a line is fitted is supposed to be a non-decreasing function of fragment size.

## Conclusion

Based on the usual liberation factor model for uncalibrated material, we have established a formal model of liberation factor that can be used for controlling the sampling variance in "closely sieved" material (i.e. calibrated), which constitutes a huge step ahead of Gy's legacy about the  $g'(r)$  alternate factor. Let us recall that in this expression, 'closely sieved material' is a reference to the terminology in Gy's study of the  $g'$  granulometric factor, but the two screens can actually be of largely different sizes without negative effects on the accuracy of the results.

This study also provided a rigorous methodology to use calibrated material (i.e. successive size fractions) for heterogeneity testing, and for the addition of uncalibrated material on the same model-fitting graph, even though these operations are quite safe and forgiving.

## References

1. Gy, P.M. 1967. L'Echantillonnage des Minerais en Vrac, Tome 1. in Mémoires du BRGM, No. 56. Editions BRGM. Paris. 189.





## Theory of Sampling and QAQC enabling the application and expectations of new technology and data processing

---

Oscar Dominguez

Global Principal QAQC, Resources Centre of Excellence, BHP. E-mail: [oscar.r.dominguez@bhp.com](mailto:oscar.r.dominguez@bhp.com)

Member of the World Sampling Council, The International Pierre Gy Sampling Association.

---

Currently, there are high expectations in the mining industry, across the Supply Chain, on how sensors and new technology providing real time data can support and optimise business decisions. In addition, sophisticated statistical algorithms, such as machine learning or conditional simulations, are more and more explored/used to address topics as uncertainty and “optimisations” in the plans, at different horizons, to “maximise the value of the business”.

Despite the future of data collection is heading in the direction where sensors will be providing real time information, this is still in the development stage. The main challenge of the current status for sensors, new technology or statistical analysis, is that they are mostly based on the assumption that the data used during calibrations or data processing, is correct or representative.

This paper elaborates in more detail (with examples) on how the Theory of Sampling and the implementation of Quality Programs (QAQC & QM), across the supply chain, represent key enablers in the research, applications, selections and implementation of technology providing real time data, as well as the quality quantification of the information used as input for data processing: what a sampling protocol represents, how main and deleterious elements are distributed in the lot to be sampled, grade per grain size distribution profile, what can impact sample collection process, how gaps during sample collection shall be monitored, sources of bias, sources of variability and how this information can be used to quantify the current quality performance that will need to be improved with the technology. This paper also elaborates on the current expectations of minor/trace element data (normally on ppm levels), specifically in the understanding and challenges these types of data represent. The final objective of this analysis is to highlight the potential impacts during a capital process where new technological projects can be wrongly excluded from consideration due to errors in the baseline used for comparison, as well as the potential impact on reconciliation and marketing results due to technology or statistical analysis using biased datasets.

### Introduction

Currently, there are high expectations in the mining industry, across the Supply Chain, on how sensors and new technology providing real time data can support and optimise business decisions. In addition, sophisticated statistical algorithms, such as machine learning or conditional simulations, are more and more explored/used to address topics as uncertainty and “optimisations” in the plans, at different horizons, to “maximise the value of the business”.

Despite the future of data collection is heading in the direction where sensors will be providing real time information, this is still in the development stage. The main challenge of the current status for sensors, new technology or statistical analysis, is that they are mostly based on the assumption that the data used during calibrations or data processing, is correct and representative, which provides two streams of different perspective for development: 1) Have the quality of the current samples/data being quantified? Are the main sources of errors and biases being identified, understood, and considered within the baseline the new technology is going to be measured against? What is the current quality performance (bias and precision) of the process that is going to be potentially replaced by new technology? And 2) On sensors and new technology, what controls are used to measure the performance in terms of quality? Are all the sources of bias and variability considered and their impact quantified? Is the implementation of a Quality Program (QAQC) to monitor/measure the quality of the instruments considered? (**Figure 1**)

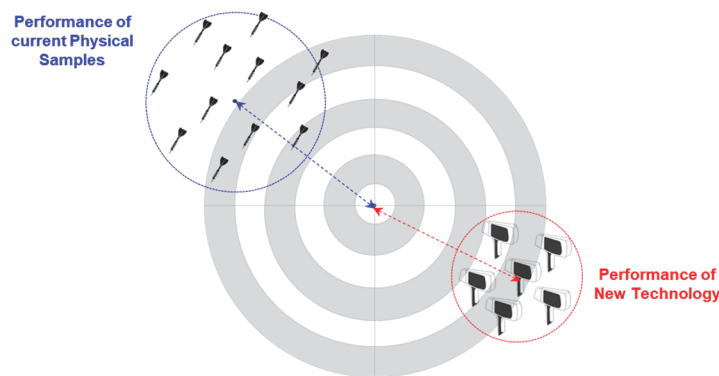

**Figure 1.** Scheme showing the considerations to be addressed where testing new technology versus physical samples.

Despite there is potential for a future where the collection, preparation and analysis of physical samples can be replaced by sensors and sophisticated data processing, the reality is that even in that future, the Theory of Sampling will remain relevant because it will provide the guidelines and parameters to be considered within the baseline equation to measure sensors and technology optimisations, and compare quality performance against; and also, how Quality Programs will need to be considered and adjusted to ensure sensors and new technology are delivering a representative measurement. Today, this is not always considered, and the risk for good technological tools being rejected because of subjective high expectations of the current situation, or important investment decisions on technology where maybe is not need it, is very high.

The mining industry is facing big challenges on the consistent reduction of production grades, more complex geological environment, tighter environmental requirements, and the increasing economic value and attention for minor elements at part per million (ppm) levels. In addition, we have the increasing desire in the mining industry for new technology to give us the answered we are searching for, but is the industry aware that all the sampling protocols have been optimised for the main elements require in production and minor elements or trace elements not? Are we considering the huge uncertainty related to ppm results? Is the industry clear that a ppm result is a number that an analytical methodology was able to determine, but that number is not necessarily representative to the amount found it in the ground?...



**Figure 2.** Sources of samples across the mining supply chain.

This paper elaborates (with some examples) on how the Theory of Sampling and the implementation of Quality Programs (QAQC & QM) across the supply chain (**Figure 2**), represent key enablers in:

- The research, applications, selection, and implementation of technology providing real time data.
- The quality quantification of the information used as input for data processing, specifically, considerations on: what a sampling protocol represents, how main and deleterious elements are distributed in the lot to be sampled, grade per grain size distribution profile, what can impact sample collection process, how gaps during sample collection shall be monitored, sources of bias, sources of variability and how this information can be used to quantify the current quality performance that will need to be improved with the technology.
- The technical expectations for minor/trace element databases, specifically in the understanding and restrictions these types of data represent.

The final objective of this analysis is to highlight the potential impacts during a capital process where new technological projects can be wrongly excluded from consideration due to errors in the baseline used for comparison, as well as the potential impact on reconciliation and marketing results due to technology or statistical analysis using biased datasets.

### **Do not forget the basics: Grade per particle size distribution, the Lot DNA versus Sample DNA**

The most basic concept on Theory of Sampling is that a “sample is part of a lot”, and for a sample to be called “representative”, it needs to include all the components of the lot, in the same proportions. Any deviation of this principle will generate deviations in the sample collected.

Currently, the characterisation of mining resources is performed, in general, at Head Grade level, where just a “number” is used to represent a sampling interval in a drillhole, or a production area in grade control, or an individual block in a block model, or thousands of tonnes production on a conveyor belt, or a full shipment of final product. This is where the concept of “Lot DNA and Sample DNA” becomes relevant. Lot DNA refers, on a sampling perspective, to the study and characterisation of the grade distribution (main and minor elements) across the particle size distribution (**Figure 3**), with the objective of understanding the proportions in the lot that needs to be preserved in the sample collected (sample DNA). By having characterised the particle size distribution profile, it is going to be easier to understand the impact in the Head Grade for issues during sample collection affecting preferential particle sizes (fine or coarse fractions), especially sources of underestimation or overestimation of the main production elements, but also for minor elements and trace elements.

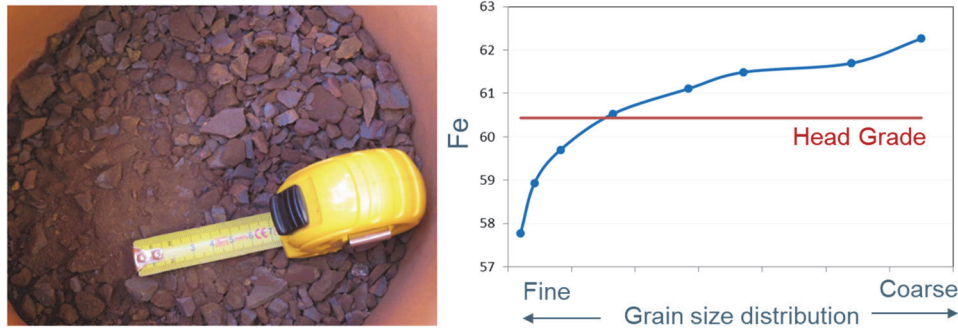

**Figure 3.** Example Fe grade per size distribution in an Iron Ore sample. In this example, Fe is located in the coarse part of the sample, so preferential sampling of this particle size will overestimate the Fe in the Head Grade of this sample. Note: It is also suggested to include mineralogy in the grain distribution profile, especially for geometallurgical purposes.

The importance of the understanding and consideration of the DNA will be relevant in the capacity of new technology to measure the full DNA and not just parts of it, especially when related with particular grain sizes in the lot, that will impact the representativeness (and a highly potential bias) of the measurement. Currently, it is valuable to get a real time measurement, but it is more relevant to get a representative measurement in order to optimise further decisions and final financial outcomes...

**The context behind Sampling Protocols vs business expectations**

In regard to Sampling Protocols, and how they can influence new technological results, it is necessary to consider and highlight the strategy established when heterogeneity studies were performed to optimise the Sampling Protocol and the Fundamental Error of the main elements required in the supply chain, where 1) in minor elements, it is expected to have a bigger Fundamental Error because they are not normally prioritised in the strategy, and 2) it is expected to have even more error in trace elements (**Figure 4**).

Example Fundamental Error ( $\sigma_{FE}^2$ ) of Sampling Protocols on different elements in a copper mine

$$\sigma_{FE}^2 = \left( \frac{1}{M_S} - \frac{1}{M_L} \right) \cdot C \cdot d^{\beta} \approx \frac{1}{M_S} \cdot C \cdot d^{\beta}$$

UG	Protocol	CuT	Fe	As	Mo	Pb	Au	Trace Elements
1	DDH	1.6	1.9	3.3	3.6	5.6	9.5	>>10
	RC	3.2	3.6	4.3	6.1	8.9	9.9	>>>10

**Figure 4.** Example on how the Fundamental Error on Sampling Protocols varies per elements and their prioritisation strategy.

This is important to be highlighted, because the error and uncertainty associated with an “assay number” stored in a database will vary depending on the importance of the element for the business when the sampling protocol was designed. For example, in a copper mine, sampling protocols are expected to be optimised for copper (with a lower error), but not necessarily for minor elements or trace elements. This situation raises several points that needs to be considered when new technology is trying to be applied at minor or trace elements concentrations:

- Because the sampling protocol used to collect and prepare the samples was not designed for minor or trace elements, it needs to be highlighted that the assay result in the database it is expected to have a big uncertainty and questionable representativeness against the lot. In other words, if we have 150 ppm of a trace element, due to the sampling protocol, it is expected to have a big variability in the measurement at 95% confidence, it means, it can be 150 ppm ± 50 ppm, or ±100ppm, etc, the expected standard deviation it is expected to be very important.
- Another point is related to the representativeness of these 150ppm against the original lot. Because of what has been

explained on the sampling protocol, this “assay result” has a highly questionable representativeness against the original lot. It is very unlikely that the exact 150 ppm are going to be found in the lot sampled.

- Before utilising physical samples as a reference for minor or trace elements, it is important to consider the QAQC program was used on the analytical process (ICP). Were Certified Reference Material (CRM) used and evaluated for those minor or trace elements? Has the CRM been certified by ICP?

All these points are highly suggested to be considered when new technology is trying to be applied on minor or trace elements concentrations. Results are very likely to be imprecise, but not necessarily due to issues in the sensor itself. Maybe the main source of variability is coming from the sample used in the calibration, and this variability in the absent of an understanding on the restrictions on the physical samples data, can lead to wrong decisions about the performance of the technology. This is the value of a quantified and understood quality, and restrictions of the baseline representing current situation to be potentially replaced.

Note: This is important as well on the high expectations or uses, business is trying to give to ICP data to potentially evaluate, reprocess, and recover Rare Earth, or for thresholds on ppm level defined by environmental requirements. The question is whether industry is prepared to meet the expected low variability at ppm levels?

**Sources of variability and bias to be considered when trialling new technology**

When trialling new technological applications across the supply chain, it is important to consider and have quantified all the potential sources of error and bias (Dominguez, 2019)<sup>4</sup>. Normally these sources are not considered by providers and developers, and they just rely in the number o result provided by the instrument, not quantifying or challenging the representativeness of the measurement.

Example sources of variability

Sample grain size heterogeneity is going to play a key role when trialling new sensors or technology: the coarse and heterogeneous the material to be measured is, the larger the expected variability will be (Figure 5), and this is important to be considered because technological applications on conveyor belts, for example, can be dismissed because of wrong expectations of a lower variability in the results. In addition, if the full sampling process is not understood (collection, preparation, and analysis), providers can be promising better precisions against just the analytical part, but not considering the sample heterogeneity during sample collection in their equation, where ~80% of error is introduced.

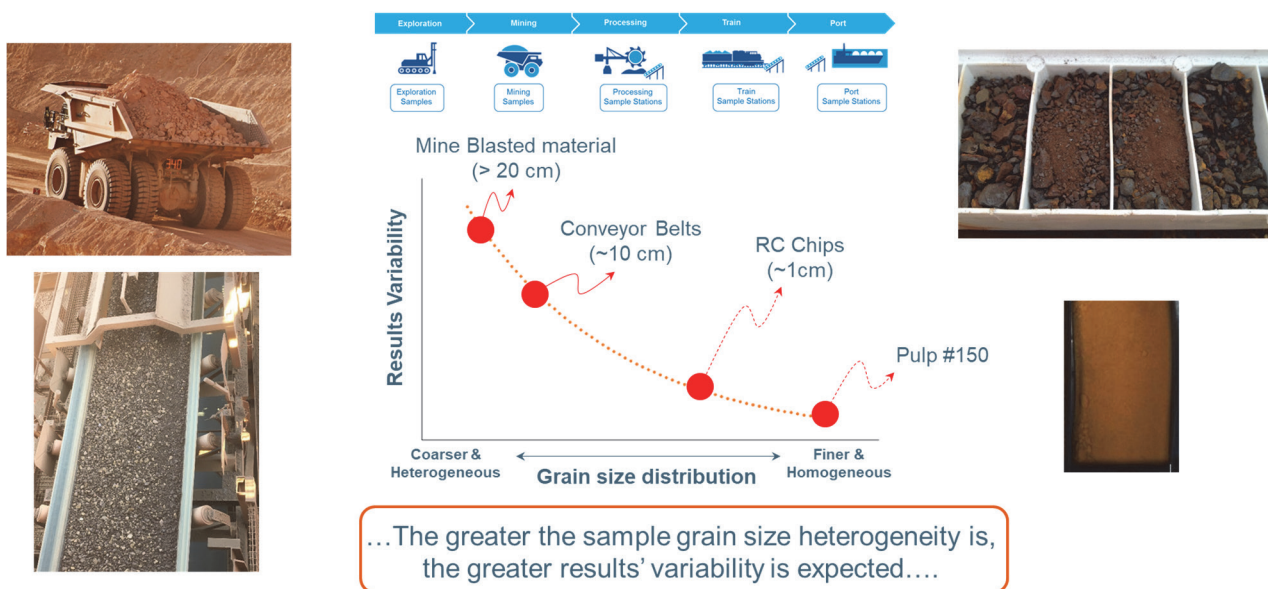

... The greater the sample grain size heterogeneity is, the greater results' variability is expected....

**Figure 5.** Example on expected variability versus sample grain size heterogeneity.

Example sources of bias

Sample segregation, when is not consider during sampling, has the potential of representing an important source of bias in the measurement of new technologies, if they are not able to cover the full stream of sample that is required to be measured. For example, in conveyor belts, if sensors performing surface measurements will only be able to cover just few microns in the sample, and if the sample is including preferential particle sizes, the measurements are going to be biased and finally will not be representative...this is another reason why it is important to have characterised the DNA of the sample, in order to know the strengths and weakness of the technology trialled.

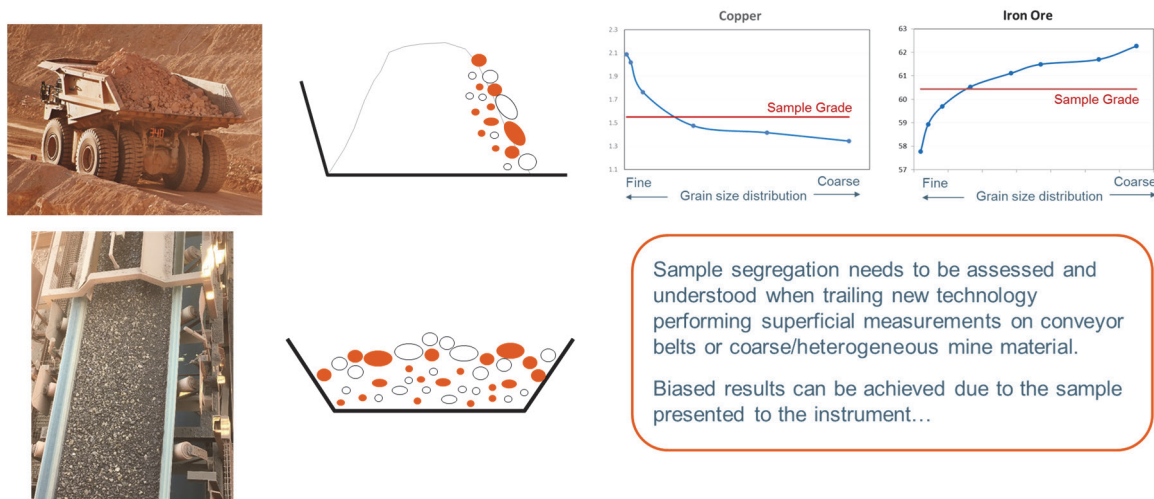

**Figure 6.** Example of segregation as a source of bias when new technology measurements are superficial and are applied on segregated lots.

### The importance of the quality quantification of the current physical samples when is compared against new technology.

An important milestone that needs to be considered, while trialling new technological applications, is the quality quantification of the current sampling state – the physical samples – that is going to be used as a baseline comparison and are expected to be replaced by technology. It is important to have quantified the performance in terms of bias and precision (variability), because in the absence of this quantification, subjective quality expectations can lead to wrong decisions for deploying or rejecting technology.

In all the sampling points in the supply chain, it is important to have quantified the performance on sample collection, sample preparation and sample analysis, in order to have objective information to be used in the comparison and better manage potential people's subjective expectations on quality: "I want to have zero error..." and also, to have a better understanding of the inputs are going to be used for the calibration of the new technology.

This quantification request will have two potential impacts: 1) The current quality performance that will need to be beaten by new technology, and 2) The quality of the information is going to be used to calibrate the new technology.

#### Example on sensors applied on conveyor belts

As a first step, it is required to have quantified the current performance of the Sample Station: have bias and precision tests been performed? Have these parameters been quantified? Has the lot DNA been characterised? In the absent of this information, the baseline to be used as comparison, is going to be unknown and will directly impact the technical decision on proceed or not with the new technology.

In addition, in the absent of a quantified performance, technology using "dynamic calibrations", it means, technology calibrations based on the physical sample collected from the sample stations, has the increased risk of been calibrated with unknown quality data, and even worse, when factors are applied on sensors or technology to mimic samples with unknown quality.

**Figure 7** shows a production report where physical samples collected from a conveyor belt and online analyser data are compared on daily basis. Report is showing a consistent difference between both sources of information. Which one is correct? In the absence of the quality quantification of the sample station, the quality of the physical samples is unknown, and also in this example, because these samples were used in "dynamic calibrations" of online analysers, the quality of this technology is also unknown. But if the quality of the physical samples has been quantified (bias and precision test performed), then is more likely an issue in the calibration of the online analyser.

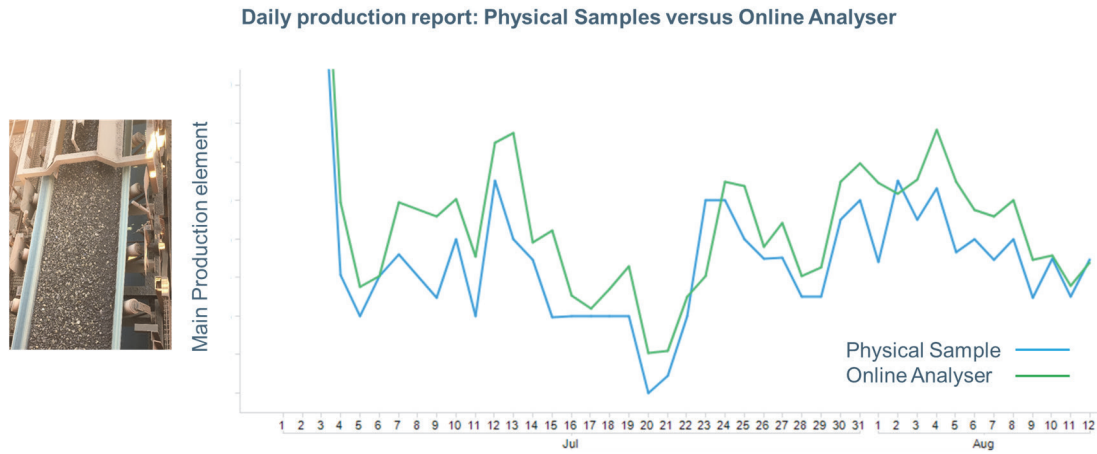

**Figure 7.** Daily production report showing data from Physical samples versus Online Analysers. Report is showing a consistent difference between both sources of information. Which one is correct?

Unfortunately, the current assumption in the industry is normally to say that the sensor is having calibrations issues, but this is just an assumption. What happen if the samples are biased?

In terms of the quality performance of new technology, it is highly desired to apply a “static calibration”, which refers to the use of an independent reference material to measure the performance and isolate the pure performance of the technology, as a simile of the Certified Reference Material (CRM) that are used during sample analysis in laboratories to independently measure the accuracy of the analysis.

Returning to **Figure 7**, if a static calibration has been performed in the Online Analyser, we have an independent tool supporting the performance of the sensor, so now, is more likely that the physical samples are having a negative bias. Having a more long-term view of these sensors, they represent a robust tool that can be used as a Quality Control, to monitor the information provided by physical samples.

Unfortunately, these independent measurements are not very often considered, and providers rely in the samples provided by companies and are just assumed as representative.

Blasthole samples considered as reference for technology calibrations

When new technology is trying to be trial on blastholes, as has been repeatable mentioned, it is very important to have quantified the current performance of the manual blasthole sampling and to have identified all the potential sources of gaps on sample collection, preparation, and analysis, in order to have robust baseline to compare new technology against.

**Figure 8** shows an example in blastholes on why it is important the understanding, on a sampling perspective, of the sources of gaps impacting the quality of the manual sampling is going to be used as a baseline and inputs for calibration. In this example, a) DNA is indicating the high-grade material is located in the fine fractions, b) field inspection is showing serious gaps during sample collection, with a preferential trend towards the collection of fine fractions, c) comparison between grade control model, based on blastholes, showing a consistent overestimation of the grade against the long-term model. This information needs to be considered, because the new technology is going to be calibrated and compared against inputs with serious sampling issues.

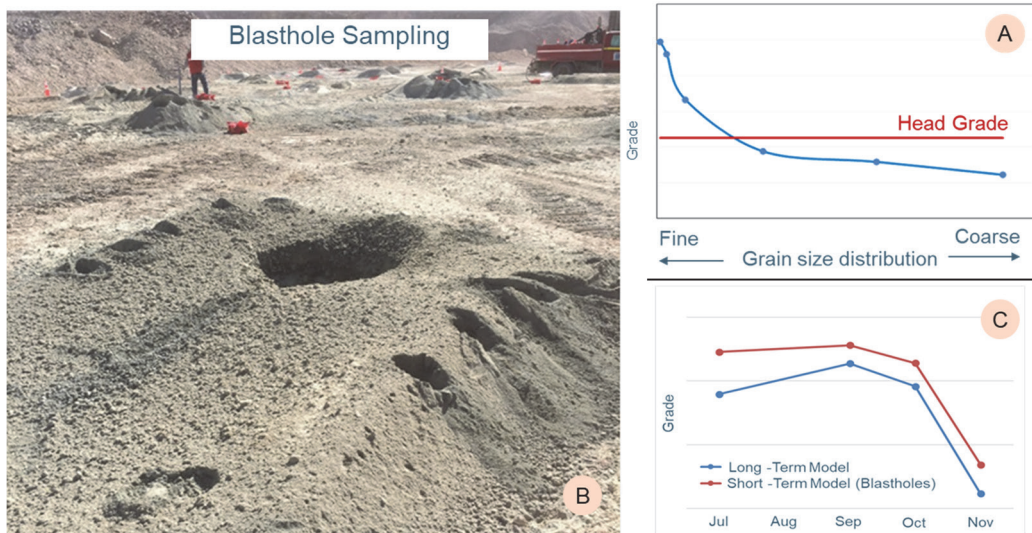

**Figure 8.** Example of the importance for having a good understanding of the sources of sampling gaps impacting the quality of the physical samples are going to be used as a baseline and calibration for new technology.

Similar considerations need to be taken in account when new technology is planned to be applied on drilling methodologies as Reverse Circulation (RC) or Diamond (DDH). Parameters such as Sample DNA, recovery, sample weight and the results of the QAQC program during sample collection, preparation, and analysis, that are going to allow an objective quality comparison with the new technology (Chi *et al*, 2017)<sup>2</sup>.

#### Quality Programs – QAQC – are also required on new technology

Having the context now on the big importance sampling and QAQC considerations have to define an objective baseline to compare and calibrate new technological applications, it also important now to consider what is going to be the QAQC program and Quality Management – QM – (Dominguez, 2021)<sup>3</sup> the new technology needs to implement, which are the restrictions of the sensors, and which are the parameters that need to be monitored.

For example, hyperspectral technology has been applied in greenfield exploration, drillholes, mine face scanning and also trailed in conveyor belt to determine the mineralogical composition of the lot. The key parameters that shall be monitored under a Quality Program are the wavelength and reflectance (Mittrup *et al*, 2017)<sup>1</sup>, in order to have consistent measurements of the spectra (**Figure 9**). Deviations in this monitoring have shown differences in the measurements between the day and the night due to temperature variations. Also, it is important to consider in the evaluation what kind of maintenance program will need to be implemented and how they are going to impact the process (in conveyor belts, for example). Finally, it is also important to know and understand the restrictions of the different methodologies: if they are a superficial measurement or if they are a volumetric measurement, because if the measurement is just few microns deep in the sample, all the theory of sampling will have an impact in the interpretation obtained.



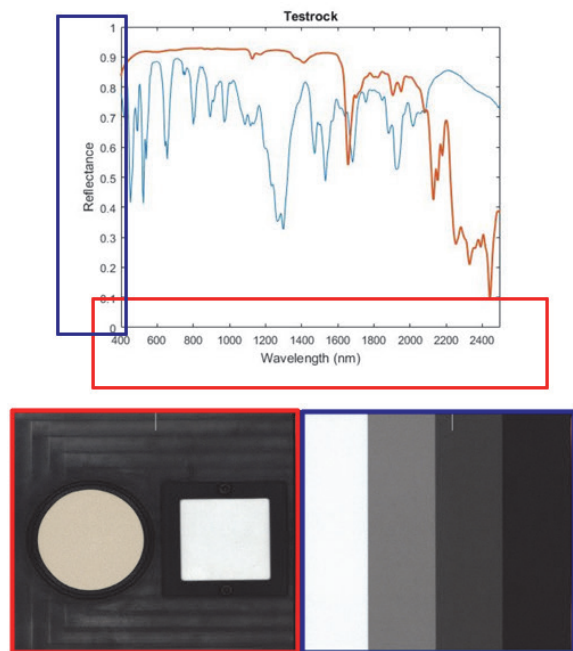

### Calibration plates

- Doped Spectralon plate covering absorption features in the VNIR-SWIR wavelength range
- Mylar draped over spectralon – sharp absorption features in the long wavelength range for tracking wavelength precision
- Multireflectance spectralon plate – reflectance variations from near complete absorption to near complete reflection across the VNIR-SWIR in four steps to control reflectance levels

Figure 9. Example of QAQC Program applied on hyperspectral data.

### Uncontrolled advanced statistics: high risk for quality

Something to be highlighted as well, in this industry desire of having real time data to perform real time decisions, is the risk of using advanced statistics, as machine learning or simulations, to mathematically close gaps in the mining supply chain through modifying factors, but not giving the business the chance to address and fix the root cause of the gaps determined in the samples/inputs affected. This false sense of “optimisation” has the potential to hide consistent inefficiencies or gaps in the inputs (samples or technology) used in the supply chain. So, it is important to highlight the risk of using an uncontrolled advanced statistic: instead, it is better to have a quality quantified sampling performance based on a robust Quality Program.

### Conclusions

Currently, there are high expectations in the mining industry, and across the Supply Chain, on how sensors and new technology providing real time data, can support and optimise business decisions. In addition, sophisticated statistical algorithms, such as machine learning or conditional simulations, are more and more explored/used to address topics as uncertainty and “optimisations” in the plans, at different horizons, to “maximise the value of the business”.

Despite the future of data collection is heading in the direction where sensors will be providing real time information, this paper highlights the current technical challenges to be considered in the current stage, where the main opportunity of the current status for sensors, new technology or statistical analysis, is that they are based on **just** the assumption that the samples/data used during calibrations or data processing, is correct or representative.

This paper highlighted the importance of the Theory of Sampling and Quality Programs (QAQC & QM), as an enabler for an informed technical assessment to be considered, before a new technology or data analysis is deployed, to:

- ✓ Quantify the quality of the current sampling methodology to be replaced.
- ✓ Understand the uncertainty behind the assay results stored in a database, especially for minor and trace elements.
- ✓ Support the definition of the baseline comparison between the physical sample and the new technology.
- ✓ Define a Quality Program (QAQC & QM) to be implemented in the new technology.
- ✓ Highlight risks and manage expectations for uncontrolled advanced statistical analysis.

Through some examples, this paper aimed to contribute to the understanding and suggestions on what parameters on sampling and QAQC could be considered in the assessment of new technology to technically support business decisions.

### References

1. Mittrup, Dominguez & Haest (2017). A new approach to implement QAQC to technological innovations - quality on spectral data capture and process flow in the minerals industry. WCSB8.
2. Chi, B, Maddever, R A M, Mahanta, A and Dominguez, O, 2017. x000D\_Near real-time assay with downhole assay tool (FastGrade 100), in Proceedings Eighth World Conference on Sampling and Blending, pp 137-144 (The Australasian Institute of Mining and Metallurgy: Melbourne).

3. Dominguez (2021). Quality Management (QM): The heart of the QAQC process. *Spectroscopy World*, Vol.33 No1. February 2021.
4. Dominguez (2019). Applications for Portable XRF Analyzers. PDAC 2019. Toronto, Canada.



## Calibration of K and alpha ( $\alpha$ ) for bulk commodities

R.C.A. Minnitt<sup>a,\*</sup>, D.K. Mukhopadhyay<sup>b</sup>, and L. Lautze<sup>c</sup>

<sup>a</sup>School of Mining Engineering, University of the Witwatersrand, Private Bag 3, WITS. 2050. Johannesburg, South Africa. Email: [Rich-ard.Minnitt@wits.ac.za](mailto:Rich-ard.Minnitt@wits.ac.za)

<sup>b</sup>Manager, Resource and Reserve Governance, South32. E-mail: [Dk.Mukhopadhyay@south32.net](mailto:Dk.Mukhopadhyay@south32.net)

<sup>c</sup>Principal, Resource Geology, South32. E-mail: [Livhuwani.Lautze@south32.net](mailto:Livhuwani.Lautze@south32.net)

In order to minimise the sampling error and sampling bias associated with the sampling of metal bearing ores it is essential that the heterogeneity characteristics of the ores be fully appreciated. Heterogeneity tests were carried out on the significantly different manganiferous ores produced at Wessels and Mamatwan mines near Hotazel, South Africa, for the purpose of establishing an optimal sampling protocol for the ores. The method referred to as the Segregation Free Analysis (SFA) was used for the determination of the parameters K and Alpha by construction of calibration curves. The method involves crushing a sufficient amount of ore so that after passing it through a set of fifteen nested screens there is sufficient material to then be split into 32 samples of mass 2-5 kg, using a riffle splitter, and analysing each of the samples. Thus, for fifteen nested screens there are fifteen series each consisting of 32 samples, making a total of 480 samples for analysis. Of the eighteen elements that were analysed in each sample only %Mn<sub>3</sub>O<sub>4</sub>, %FeO, %K<sub>2</sub>O, %P, and %SO<sub>2</sub> were calibrated, the first two being the main paying elements and the last three being deleterious elements for the smelting processes in which the ores are used. Calibration curves indicate that for the coarse fraction, above 1 cm, manganese ores have alpha values close to 3, whereas those less than 1 cm in diameter have alpha values closer to 1. Reasons for this behaviour are uncertain but it could be related to the behaviour of the crystal structure in the very pure ores as the ores are progressively crushed and screened to finer size fractions. Separate nomograms were therefore prepared for the coarse and fine fractions. Net conclusions indicate that both Wessels and Mamatwan ores are relatively easy to sample and that simple two or three stage processing will suffice when preparing the final 2 g aliquot at 75 microns. Apart from minor modifications in the sample preparation protocols, there is no evidence to suggest that the Wessels and Mamatwan ores require different sample preparation protocols, or that they should be assayed differently. The calibration curves for manganese ore are compared with the calibration curves for gold bearing ores which generally have alpha values close to 1. The difference in alpha between the gold ores and bulk commodities is considered to be related to the primary distribution of the metals in nature, lognormal for gold and normal for manganese.

### Introduction

Someone has said “your decisions are only as good as your samples”. The importance of this statement and effective reach is only understood once we appreciate the way in which sample data is used and applied in the mining industry, principally in the way trading in bulk commodities and base- or precious-metals is undertaken.<sup>1,2,3,4</sup> The principle function of a sample is to fully represent the characteristics of the lot from which it is extracted. The Theory of Sampling (TS) is a systematic multistage analytical framework, a set of unifying principles to guide the processes and stages at which samples are taken. At every stage, whether the lot is moving or stationary, TS provides principles, practices, procedures, and designs for sampling equipment, to eliminate sampling bias and minimise the sampling error (precision). TS also allows to analyse and assess the potential for individual items of sampling error and bias. The TS framework is built on evaluating common problems and features encountered in sampling different lots of different sizes in different sample settings and consists of six governing principles and four sampling unit operations that are applied in a systematic fashion to all processes, procedures, and equipment. TS is therefore a framework to guarantee accuracy and precision as well as correctness and representivity in the sample materials, from lot to aliquot.<sup>5,6,7</sup>

There is no inherent feature or characteristic in sample materials that allows us to classify it as representative or not – there are no red or green flags. The only way to ensure representivity is to document the history of processes and procedures used to produce the aliquot. If the process delivering the sample aliquots for analysis is correct, the sample will be representative; alternatively, if the process is incorrect, the sample can never be representative. One might ask “What are the criteria for representivity?”. This depends on the sampling method, the physical extraction process, and the extent to which the constitutional and distributional heterogeneities of the particulate matter are accounted for.<sup>8,9,10</sup>

In the process of selecting and recovering particulate samples the TS identifies Correct Sampling Errors (CSE), and Incorrect Sampling Errors (ISE). CSEs include the Grouping and Segregation Error (GSE) and the Fundamental Sampling Error (FSE), that contribute to total sampling error. These sampling errors arise because of the constitutional and distributional heterogeneity of the materials being sampled. Failure to understand or control sampling variances due to the particle size, shape, density, mineral composition, and target analyte content of particulate materials will result in contributions of FSE from these sources. FSE, the within fragment variability in grade, volume and density is a function of particle size ( $d_N$ ), sample mass ( $M_S$ ), and the nature of the material being sampled ( $K$ ) according to Equation 1, which Gy<sup>2,3,4</sup> compiled.

$$s_{FSE}^2 = \frac{K \cdot d_N}{M_S} \quad \text{[Equation 1]}$$

According to Equation 1, the FSE can be minimised by reducing the fragment size by comminution or by increasing the sample mass. The coefficient K is the product of the mineralogical constant c, the shape factor f, the granulometry factor

g, and the liberation factor  $\ell$ . The principle inducements for GSE are an input of vibrational energy and gravity which act together to cause grouping and segregation of materials either by size or density, in a lot of perfectly dry materials, but the presence of moisture or sticky-ores strongly over-rides this distributional heterogeneity. The only way to reduce the Distributional Heterogeneity (GSE) is by incremental sampling and mixing. Collectively CSEs can never be eliminated, but they can be minimised by creating an optimal sampling protocol.<sup>7,10,11</sup>

Incorrect Sampling Errors (ISE), include Increment Delimitation Error (IDE), Increment Extraction Error (IEE), Increment Preparation Error (IPE), and the Weighting Errors (WE) which are responsible for sampling bias using poorly designed, incorrectly engineered, and badly installed sample delimitation and extraction equipment. Where particles do not have a uniform, non-zero probability of being delimited and extracted, ISEs are to be expected. Where these sampling errors and sampling biases are controlled, where an optimal sampling protocol has been applied, and a documented history of the sampling process is available, an aliquot, immediately prior to its presentation to the analytical process, is very likely to be fully representative of the lot from which it is derived, because it is the product of a correct, representative multistage sampling process.<sup>5,7</sup>

The aim of this paper is to present the results of heterogeneity testing of manganese ores from two mines in the Hotazel region of South Africa and to compare the sampling parameters for these bulk commodities with those for precious metals.

### Review of heterogeneity tests

The first step in creating the optimal sampling protocol is the performance of a heterogeneity test which provides an understanding of the Fundamental Sampling Error (FSE). The aim of the heterogeneity test is principally to establish how the variance amongst a series of samples changes as the size of the fragments in the sample changes as the material is reduced through different stages of comminution and mass reduction on its way to the aliquot that is presented for assay. Sampling parameters K and Alpha are estimated on a size-by-size analysis of the variance of the target analyte in different size fractions of particulate materials, allowing the FSE to be calculated and controlled to acceptable levels. The heterogeneity characteristics of each material to be sampled, namely the parameters K and Alpha, are determined by compiling a calibration curve which models the way in which the variances of the target analyte change for different sized particles. Once the parameters K and alpha have been established it is then a simple task to compile the sampling nomogram which is a blue-print for the sampling protocol that defines the relationship between the variance of the Fundamental Sampling Error (FSE) and the sample mass.<sup>12,13,14</sup>

While there are several studies that have undertaken to determine the parameters for base and precious metals<sup>12,14,15,16,17</sup>, the determination of sampling parameters for K and Alpha for bulk commodities, such as iron ore, manganese ores, vanadium ores, chromite ores are not widely publicised. The reasons for the lack of reported heterogeneity tests for bulk commodities is probably due to the relatively forgiving sampling characteristics of these ores compared to the complexities associated with precious and base metal ores. The target analyte, Fe or Mn, in bulk materials for example is contained in the minerals haematite or braunite-pyrolusite-bixbyite constituting the ore, and there is no effective liberation factor. Where the target analyte is contained as minute grains of mineral or metal, distinct and separate from the host, the liberation factor is an extremely important contributor to the constitutional heterogeneity.

There is a wide spectrum of different approaches for performing Heterogeneity Tests.<sup>4,5,6,7,8</sup> For this particular exercise the so-called Segregation Free Analysis (SFA) method described in detail by Minnitt<sup>12,13,14,15</sup> is used. The SFA method is a simple extension of the Duplicate Series Analysis (DSA) method proposed by Bongarçon<sup>15,16,17</sup>, the main difference being that the SFA method separates the crushed materials for the heterogeneity test into different size classes.

### Heterogeneity tests for bulk commodities

As part of a review of the sampling facilities and procedures at the Wessels and Mamatwan mines near Hotazel, South Africa, it was suggested that Heterogeneity Tests be carried out on the manganiferous ores produced at the mines. The manganese bearing ores produced at the mines are sufficiently different to warrant that the Heterogeneity Tests be carried out on both ore types. Of the several methods for performing Heterogeneity Tests, the Segregation Free Analysis (SFA) method was used for determining the parameters K and Alpha by construction of calibration curves for the differing ore types produced at Wessels and Mamatwan mines. Approximately 180 kg of high-grade, run-of-mine manganese ore from the Wessels and Mamatwan mines was crushed and screened through 15 individual screens ranging in size from 37.5 mm to 0.05 mm; it is essential that the largest fragment sizes are accurately represented in the heterogeneity test. Finer materials were passed through the nested screens (Figure 1a) using a mechanical shaker (Figure 1b), and the fragments on top of each screen were selected for a given size fraction. After crushing the ore to appropriate sizes, the material was screened through 15 screens for Wessels ores and 14 screens for Mamatwan ores. The material retained on top of each screen size was then passed through a riffle splitter to give 32 samples for each size fraction.



Figure 1: (a) Nested screens for separating ores into correct size fractions, and (b) the mechanical sieve shaker. The distribution of the mass for each of the screened size fractions is shown in Figures 2a and 2b for the Wessels and Mamatwan mines, respectively.

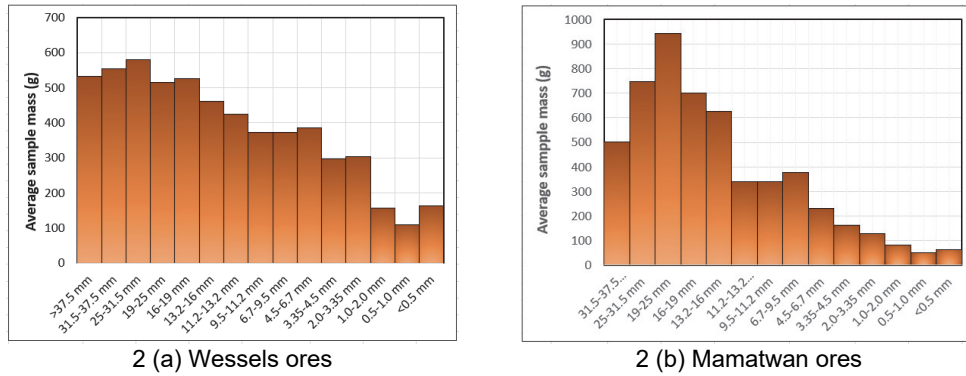

Figure 2: (a) Average sample mass for each of 15 size fractions of Wessels ores, and (b) average sample mass for each of 14 size fractions of Mamatwan ores

Ideally one would want the distribution of the mass of fragment sizes to be somewhat flatter than shown in Figures 2a and 2b, as there is too much material in the higher size fractions and too little material in the lower size fractions to get an acceptable sample mass when the size fractions are split into the 32 sample fractions. In order to achieve this some of the excess material in the larger size fractions was crushed and again passed through the screens to distribute the material to smaller size fractions.

Once the Mamatwan and Wessels ores had been divided into 14 and 15 series of samples, respectively, each of the series was then split into 32 individual samples. The series containing larger fragment sizes had fewer fragments per sample, whereas the smaller fragment sizes contained numerous fragments. Each sample was intended for an experimental point in the calibration curves used to determine the values of K and Alpha ( $\alpha$ ) for use in Gy's Formula for determination of the Fundamental Sampling Error and construction of the sampling nomogram for the Wessels and Mamatwan ore-types.

### Sample preparation protocol for Wessels and Mamatwan ores

The sample preparation protocol for the heterogeneity test for the Wessels and Mamatwan ores was identical. For the larger fragments, the preparation protocol is shown in a series of photographs in Figure 2. The main assumption of the Heterogeneity Test is that there should be no auto-correlation between samples collected to perform the test. Fragments making up each sample are individually selected at random to remove any distributional heterogeneity and minimise the contribution from the grouping and segregation error. In order to achieve this, large fragments (>31.5 mm) were laid out on a table one fragment deep (Figure 3a) so that each and any fragment was accessible for selection. The fragments were collected at random as 4 people (Figure 3b) moved around the table and collected a specified number of fragments to produce an appropriate sample mass (Figure 3c and 3d).



Figure 3: (a) Coarse ore fragments laid on table, (b) the sampling team in preparation for selecting coarse ore fragments at random, (c) as the team moves around the table, they select a given number of fragments at random to achieve the correct sample mass, and (d) the team moves around the table collecting fragments at random

Finer grained manganese ores were split into the 32 samples using riffle splitters with vane widths in keeping with the sizes of the material fragments being sampled, an 8-vane splitter for fractions greater than 10 mm (Figure 4a) and a 20-vane splitter for fractions less than 10 mm (Figure 4b).



Figure 4: (a) Riffle splitter for coarse materials, >10 mm, and (b) riffle splitter for fine materials, <10 mm Following the splitting process, the samples are bagged (Figure 5a), weighed (Figure 5b), and prepared for dispatch to the analytical laboratories (Figure 5c).

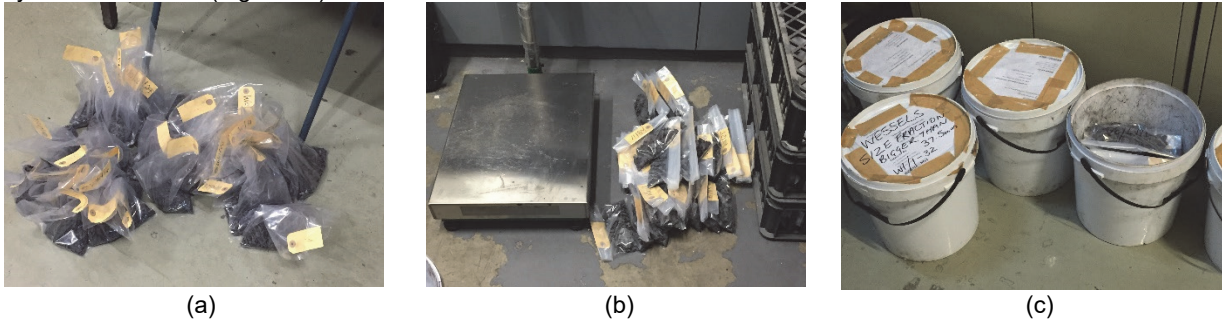

Figure 5: (a) Bagged samples, (b) all samples are weighed, and (c) Samples are packed ready for transport to the laboratory for analysis

An example of the closely screened manganese ore materials between 2.00 mm and 3.35 mm is shown in Figure 6.

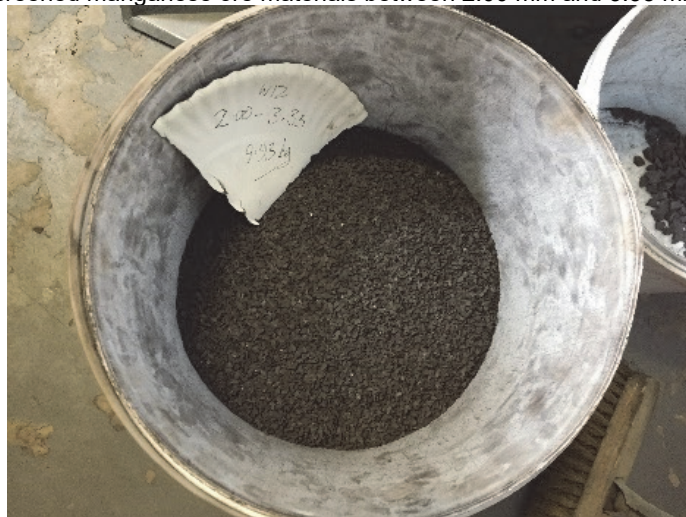

Figure 6: Closely screened manganese ore materials between 2.00 mm and 3.35 mm, with an average  $d_N = 2.659$  mm The average nominal top-size of a fraction retained between screens of 1.266 cm and 0.63 cm is calculated as follows:

Top screen (cm)	Bottom screen (cm)
1.266	0.63

$$d_N = \sqrt[3]{\frac{d_{upper\ screen\ size}^3 + d_{lower\ screen\ size}^3}{2}} \tag{Equation 2}$$

$$= \sqrt[3]{\frac{1.266^3 + 0.63^3}{2}} = \sqrt[3]{1.1396} = 1.0445\ cm$$

Using Equation 2, the average nominal top-size for the material shown in Figure 6 is calculated as 2.659 mm.

### Heterogeneity test for manganese ores

An estimate of the sampling parameters  $K$  and  $\alpha$  for an ore type allows one to calculate the FSE and provide an indication of the minimum sample mass for a given fragment size according to Equation 1. With these sampling parameters it is then possible to calculate the sampling nomogram for these specific ores. Equation [1] is rearranged in the following manner to give Equation [3] which represents a straight-line equation relating the standardised variance and the top size of the fragments in the fifteen series of data analysed.<sup>16,17,18</sup>

$$\ln(\sigma_R^2 \times M_S) = \alpha \ln d_N + \ln(K) \tag{Equation 3}$$

By calculating the standardised variance and the top-size of fragments in  $\log_e$  terms each set of fifteen analyses should plot along a straight line of the form  $y = mx + c$ .

Analytical results for each of the 32 samples in each of the series submitted for analysis were received for the elements %Mn<sub>3</sub>O<sub>4</sub>, %FeO, %K<sub>2</sub>O, %P, and %SO<sub>2</sub>. The %Mn<sub>3</sub>O<sub>4</sub> results for 32 samples across all fragment sizes are shown in Appendix 1. The total mass of sample materials received at the Mamatwan and Wessels assay laboratories for fusion and pressed pellet analysis are listed in Table 1.

Table 1: Total mass received at Wessels and Mamatwan assay laboratories for fusion and pressed pellet analysis

Laboratory	Total mass of sample received	Mass for fusion analysis	Mass for pressed pellet analysis
Wessels	100g	2g	30g
Mamatwan	200g	2g	30g

### Modeling process

The modeling process is a stepwise inspection of the lists of analytical data used in the calculation of the variances to be used in the calibration process. An example of statistics calculated for %Mn<sub>3</sub>O<sub>4</sub> from Series 2 (W2), for a fragment size of 3.4755 cm (Appendix 1), is shown in Table 2, while an example of the calculations and description of items named in the calculation table, is presented in Table 3. The modeling process requires that each assay value be considered individually and that the effects of removing suspicious values on the calibration curve should be examined. The modeling process is not simply a matter of populating a template with the sample calculations, but rather a matter of examining each set of data and examining whether or not a specific value belongs in the data set and how its inclusion or removal will affect the calibration curve. This process was carried out for each list of assay data for each of the calibration curves. In some cases, the decision to exclude certain data is always somewhat controversial. It should however be remembered that the process aims to establish a viable and acceptable model based on the data.

Table 2: Example of statistics calculated for %Mn<sub>3</sub>O<sub>4</sub> from Series 2 (W2), for fragment size 3.4755 cm,

Statistics for for %Mn <sub>3</sub> O <sub>4</sub>	W2
Mean	65.5161
Variance	38.0878
Std Dev	6.1715
Relative standard deviation	0.0942
Top screen (cm)	3.4755
Bottom screen (cm)	2.8616
Size (cm)	3.4755
Average Mass (g)	566.5000

The basic statistics shown in Table 1 are then analysed and prepared for plotting on the calibration curve according to the routine shown in Table 2.

Table 3: Example of calculations and description of items named in the calculation table for %Mn<sub>3</sub>O<sub>4</sub>, example from Series 2 (W2), for fragment size 3.4755 cm (Appendix 1)

Item	Value	Explanation
<b>d<sub>p95</sub> (cm)</b>	3.47546	Fragment top-size is a value determined for the largest 5% of fragments in a sample
<b>Measured Multi-stage rsd</b>	0.09420	The relative standard deviation (rsd = Std dev/mean) for the multiple stages of handling that a sample has been subject to, prior to fire assay.
<b>Measured Multi-stage Var</b>	0.00887	The square of the Measured Multistage relative standard deviation, to give the Measured Multistage variance.
<b>Less Analytical Var</b>	0.00887	This is a standard variance calculated from the precision usually quoted by an analytical laboratory; the generally inflated value from commercial laboratories is in the order of 9%.
<b>Standardised Var</b>	0.58130	The Measured Multistage variance less the Analytical variance is multiplied by the mean to return the value to a standardised multistage variance, rather than a relative variance.
<b>Mass (g)</b>	566.50000	This is the mass of the sample, prior to preparation steps involving crushing and splitting in the assay laboratory.
<b>s<sup>2</sup>*M<sub>s</sub></b>	329.30438	This is the Fundamental sampling variance multiplied by the sample mass.
<b>ln(s<sup>2</sup>*M<sub>s</sub>)</b>	5.79698	This is the LN value for the Fundamental sampling variance multiplied by the sample mass
<b>ln(d<sub>max</sub>)</b>	1.24573	This is the LN value for the fragment size
Note that the last two values are plotted on the abscissa (x-axis) and ordinate (y-axis) of the calibration curve		

Analysis of the calibration experiments carried out for the elements for %Mn<sub>3</sub>O<sub>4</sub>, %FeO, %Al<sub>2</sub>O<sub>3</sub>, %CaO, %K<sub>2</sub>O, %P, and %SO<sub>2</sub> was undertaken with the values for ln(s<sup>2</sup>\*M<sub>s</sub>) and ln(d<sub>max</sub>) for each element being listed in Table 4. Calibration curves for each of these elements were compiled from the analytical results for each of these elements in Figures 7 to 11.

Table 4: Compilation of values for ln(s<sup>2</sup>\*M<sub>s</sub>) and ln(d<sub>max</sub>) for each element %Mn<sub>3</sub>O<sub>4</sub>, %FeO, %K<sub>2</sub>O, %P and %SO<sub>2</sub> for Mamatwan (top row) and Wessels (bottom row) mines



Mamatwan %Mn <sub>3</sub> O <sub>4</sub>			Mamatwan %FeO			Mamatwan %K <sub>2</sub> O			Mamatwan %P			Mamatwan %SO <sub>2</sub>		
Size fraction	ln(d <sub>max</sub> )	ln(s <sup>2</sup> *M <sub>s</sub> )	Size fraction	ln(d <sub>max</sub> )	ln(s <sup>2</sup> *M <sub>s</sub> )	Size fraction	ln(d <sub>max</sub> )	ln(s <sup>2</sup> *M <sub>s</sub> )	Size fraction	ln(d <sub>max</sub> )	ln(s <sup>2</sup> *M <sub>s</sub> )	Size fraction	ln(d <sub>max</sub> )	ln(s <sup>2</sup> *M <sub>s</sub> )
1	1.39	4.62	1	1.39	3.68	1	1.39	0.58	1	1.39	-3.10	1	1.39	2.03
2	1.25	4.31	2	1.25	3.44	2	1.25	-1.53	2	1.25	-2.40	2	1.25	1.38
3	1.05	3.69	3	1.05	2.88	3	1.05	0.54	3	1.05	-2.44	3	1.05	2.97
4	0.81	2.88	4	0.81	2.04	4	0.81	-1.98	4	0.81	-3.07	4	0.81	1.56
5	0.57	2.54	5	0.57	1.42	5	0.57	-1.52	5	0.57	-3.48	5	0.57	1.78
6	0.39	2.11	6	0.39	1.59	6	0.39	-3.49	6	0.39	-4.32	6	0.39	1.01
7	0.21	0.97	7	0.21	1.42	7	0.21	-0.59	7	0.21	-3.98	7	0.21	1.17
8	0.04	0.72	8	0.04	0.44	8	0.04	-1.02	8	0.04	-4.12	8	0.04	-0.41
9	-0.18	0.01	9	-0.18	-0.96	9	-0.18	-4.52	9	-0.18	-4.77	9	-0.18	-0.87
10	-0.53	-0.62	10	-0.53	-1.54	10	-0.53	-4.39	10	-0.53	-5.66	10	-0.53	-1.57
11	-0.88	-1.49	11	-0.88	-2.63	11	-0.88	-4.73	11	-0.88	-5.30	11	-0.88	-1.51
12	-1.26	-3.02	12	-1.26	-4.11	12	-1.26	-1.64	12	-1.26	-6.45	12	-1.26	-2.63
13	-1.80	-3.07	13	-1.80	-4.78	13	-1.80	-2.35	13	-1.80	-6.10	13	-1.80	-2.05
14	-2.49	-2.91	14	-2.49	-4.33	14	-2.49	-1.75	14	-2.49	-5.58	14	-2.49	-2.60

Wessels %Mn <sub>3</sub> O <sub>4</sub>			Wessels %FeO			Wessels %K <sub>2</sub> O			Wessels %P			Wessels %SO <sub>2</sub>		
Size fraction	ln(d <sub>max</sub> )	ln(s <sup>2</sup> *M <sub>s</sub> )	Size fraction	ln(d <sub>max</sub> )	ln(s <sup>2</sup> *M <sub>s</sub> )	Size fraction	ln(d <sub>max</sub> )	ln(s <sup>2</sup> *M <sub>s</sub> )	Size fraction	ln(d <sub>max</sub> )	ln(s <sup>2</sup> *M <sub>s</sub> )	Size fraction	ln(d <sub>max</sub> )	ln(s <sup>2</sup> *M <sub>s</sub> )
1	1.39	6.45	1	1.39	6.98	1	1.39	5.87	1	1.39	0.87	1	1.39	6.04
2	1.25	5.80	2	1.25	5.86	2	1.25	4.59	2	1.25	1.34	2	1.25	5.27
3	1.05	4.95	3	1.05	5.68	3	1.05	3.35	3	1.05	-0.25	3	1.05	5.07
4	0.81	4.37	4	0.81	4.91	4	0.81	3.77	4	0.81	-0.70	4	0.81	4.38
5	0.57	3.65	5	0.57	4.66	5	0.57	3.03	5	0.57	-0.66	5	0.57	3.46
6	0.39	3.16	6	0.39	3.77	6	0.39	1.66	6	0.39	-1.88	6	0.39	2.16
7	0.21	2.29	7	0.21	3.38	7	0.21	1.33	7	0.21	-2.49	7	0.21	2.28
8	0.04	2.29	8	0.04	3.04	8	0.04	0.44	8	0.04	-2.24	8	0.04	1.88
9	-0.18	1.99	9	-0.18	2.38	9	-0.18	0.66	9	-0.18	-3.11	9	-0.18	0.69
10	-0.54	0.49	10	-0.54	0.84	10	-0.54	-0.19	10	-0.54	-3.34	10	-0.54	0.66
11	-0.91	0.04	11	-0.91	0.81	11	-0.91	0.76	11	-0.91	-3.71	11	-0.91	0.93
12	-1.26	-0.67	12	-1.26	-0.09	12	-1.26	1.10	12	-1.26	-4.01	12	-1.26	0.13
13	-1.80	-1.48	13	-1.80	-1.10	13	-1.80	0.32	13	-1.80	-5.01	13	-1.80	-0.98
14	-2.49	-2.31	14	-2.49	-1.41	14	-2.49	-2.13	14	-2.49	-4.90	14	-2.49	-1.99
15	-3.00	-2.22	15	-3.00	-0.04	15	-3.00	-1.41	15	-3.00	-4.56	15	-3.00	-0.58

Compilation of the calibration curves

Calibration curves for the elements %Mn<sub>3</sub>O<sub>4</sub>, %FeO, %K<sub>2</sub>O, %P, and %SO<sub>2</sub> for Mamatwan and Wessels as listed in Table 4, are shown in Figures 7 to 11; calibration curves for Mamatwan ores are shown in red, while those for the Wessels data are shown in yellow. In view of the obvious inflection in the calibration curves at an approximate fragment size of 0.9 cm, the curves have been split into calibration points with fragments greater than 0.9 cm, and those whose fragment size is less than 0.9 cm. As a result, for each element shown in Figures 7 to 11, three modelling curves are shown, (a) a model using all the data (upper panel), (b) a model using only fragments larger than 0.9 cm, and (c) a model using only fragments less than 0.9 cm. The calibration curves modelled in the upper panels of each figure used all the available data. The data was split at the inflection points in the curve, above and below the point where the fragment size is about 0.9 cm. Models for fragment sizes >0.9 cm shown in the lower LHS panel (b), generally have steeper slopes, while models for fragment sizes <0.9 cm shown in the lower RHS panels (c), have much flatter slopes. The straight-line equations for the Wessels data are shown in the upper LHS of the calibration curves, while those for the Mamatwan data are shown in the lower RHS of the calibration curves in Figures 7 to 11.

Calibration curves: Mn<sub>3</sub>O<sub>4</sub>

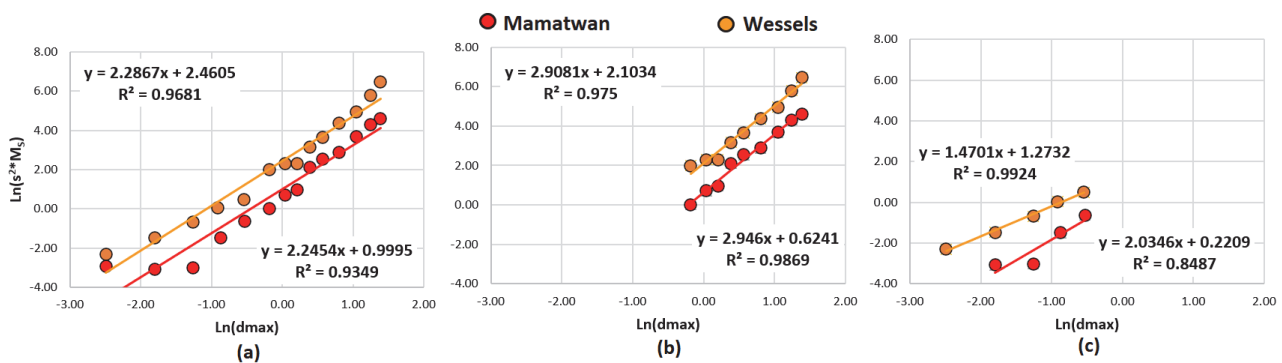

Figure 7: Calibration curves for %Mn<sub>3</sub>O<sub>4</sub> for Wessels (orange points) and Mamatwan (red points) ore-types: (a) unadjusted model in upper panel, (b) adjusted models for fragments >0.9 cm in lower LHS panel, and (c) adjusted models for fragments <0.9 cm in lower RHS panel. Linear trendlines-upper LHS for Wessels ores, lower RHS for Mamatwan ores

Calibration curves: FeO

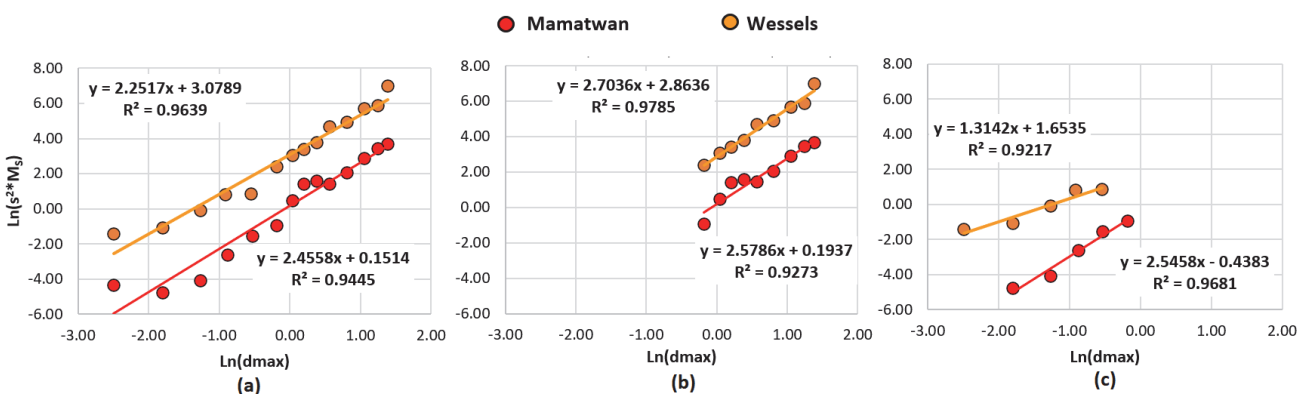

Figure 8: Calibration curves for %FeO for Wessels (orange points) and Mamatwan (red points) ore-types: (a) unadjusted model in upper panel, (b) adjusted models for fragments >0.9 cm in lower LHS panel, and (c) adjusted models for fragments <0.9 cm in lower RHS panel. Linear trendlines-upper LHS for Wessels ores, lower RHS for Mamatwan ores

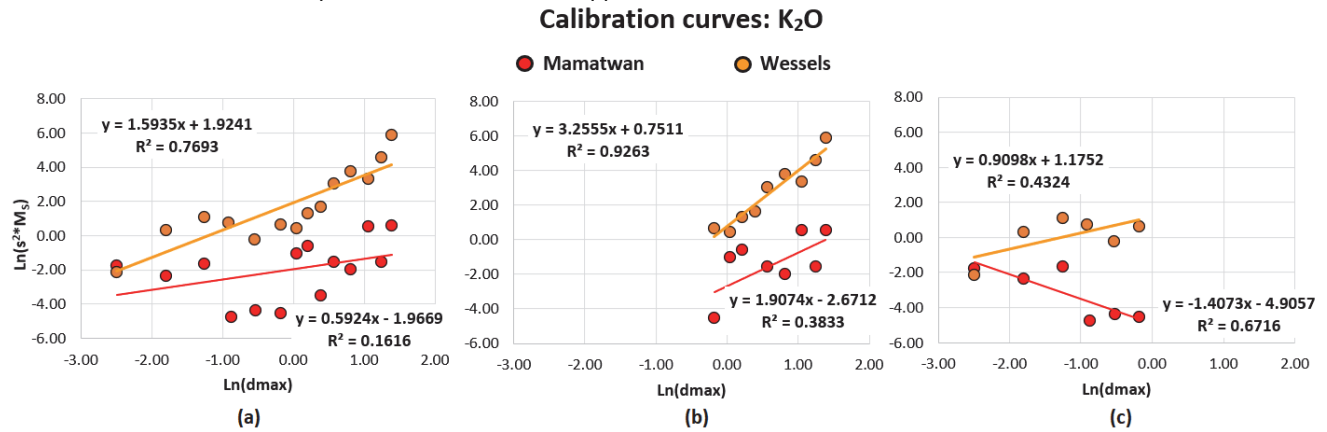

Figure 9: Calibration curves for %K<sub>2</sub>O for Wessels (orange points) and Mamatwan (red points) ore-types: (a) unadjusted model in upper panel, (b) adjusted models for fragments >0.9 cm in lower LHS panel, and (c) adjusted models for fragments <0.9 cm in lower RHS panel. Linear trendlines-upper LHS for Wessels ores, lower RHS for Mamatwan ores

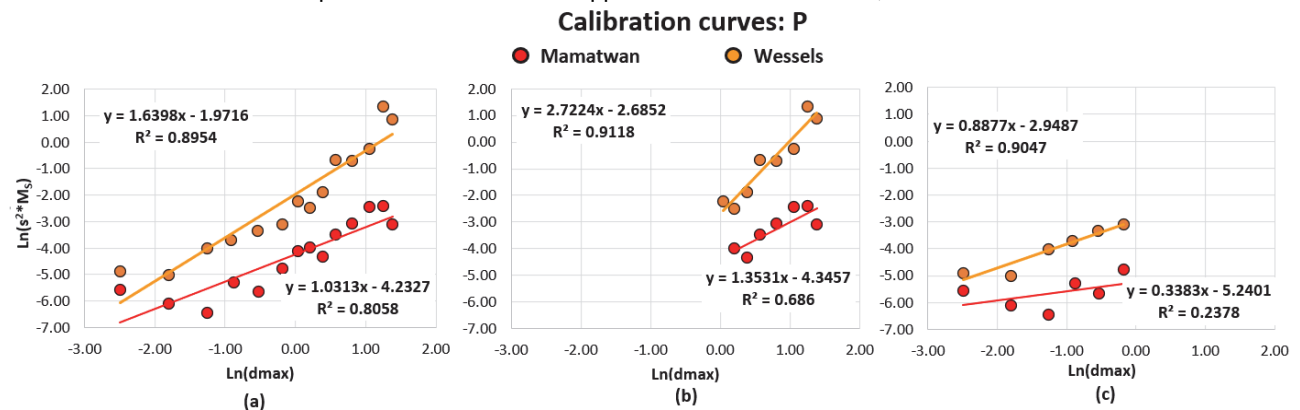

Figure 10: Calibration curves for %P for Wessels (orange points) and Mamatwan (red points) ore-types: (a) unadjusted model in upper panel, (b) adjusted models for fragments >0.9 cm in lower LHS panel, and (c) adjusted models for fragments <0.9 cm in lower RHS panel. Linear trendlines-upper LHS for Wessels ores, lower RHS for Mamatwan ores

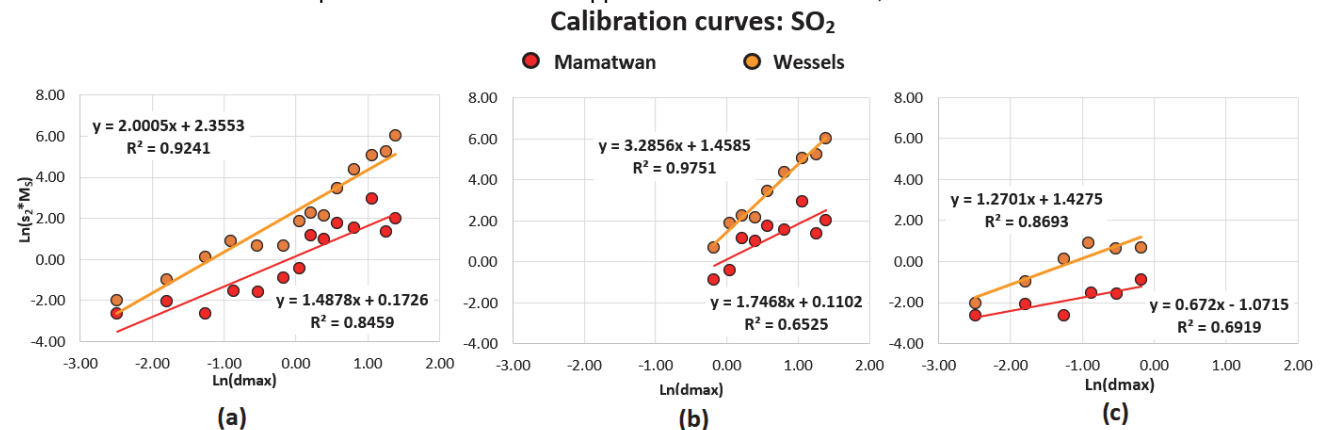

Figure 11: Calibration curves for %SO<sub>2</sub> for Wessels (orange points) and Mamatwan (red points) ore-types: (a) unadjusted model in upper panel, (b) adjusted models for fragments >0.9 cm in lower LHS panel, and (c) adjusted models for fragments <0.9 cm in lower RHS panel. Linear trendlines-upper LHS for Wessels ores, lower RHS for Mamatwan ores

Values for the slope Alpha ( $\alpha$ ), intercept K, and the R<sup>2</sup> values taken from trendlines through the calibration points are summarised in Table 5. For each of the elements analysed the R<sup>2</sup> value is considerably improved for all the curves showing only the coarser fragment sizes. Another feature is that Alpha ( $\alpha$ ), the average slope for all elements, in the coarser grained materials for Mamatwan and Wessels, increases from 1.57 to 2.11 and from 1.95 to 2.98, respectively. In a similar way the average slope for all elements in the finer grained materials for Mamatwan and Wessels, decreases from 1.57 to 0.84 and from 1.95 to 1.17, respectively. This indicates that the rate of change in variance is more marked for coarser materials than for the finer.

It is also notable that the average intercept (K) for all elements (except %P) in the coarser grained materials for Mamatwan and Wessels, decreases from 1.30 to 1.07 and from 12.71 to 8.03, respectively. In a similar way the average intercept (K) for all elements in the finer grained materials for Mamatwan and Wessels, decreases from 1.30 to 0.29 and from 12.71 to 4.05, respectively. Decreases in the average intercept (K) means that there is less likelihood that the sample nomogram will breach the 10% Safety Line.

Table 5: Summary of calibration parameters for the slope Alpha ( $\alpha$ ), the intercept on the Y-axis K, and the R<sup>2</sup> for all available data, for fragment sizes >0.9 cm and <0.9 cm derived from the calibration curves shown in Figures 7 to 11 for the elements %Mn<sub>3</sub>O<sub>4</sub>, %FeO, %K<sub>2</sub>O, %P, and %SO<sub>2</sub> from the Mamatwan and Wessels mines

	Using all data		Fragment sizes >0.9 cm		Fragment sizes <0.9 cm	
%Mn <sub>3</sub> O <sub>4</sub>	Mamatwan	Wessels	Mamatwan	Wessels	Mamatwan	Wessels
Alpha	2.2867	2.2454	2.946	2.9081	2.0346	1.4701
InK	0.9995	2.4605	0.6241	2.1034	0.2209	1.2732
K	2.7169	11.7107	1.8666	8.1940	1.2472	3.5723
R2	0.9349	0.9681	0.9869	0.9349	0.8487	0.9924

	Using all data		Fragment sizes >0.9 cm		Fragment sizes <0.9 cm	
%FeO	Mamatwan	Wessels	Mamatwan	Wessels	Mamatwan	Wessels
Alpha	2.4558	2.2517	2.5786	2.7036	2.5458	1.3142
InK	0.1514	3.0789	0.1937	2.8636	-1.0791	1.6535
K	1.1635	21.7345	1.2137	17.5245	-0.4383	5.2252
R2	0.9445	0.9639	0.9273	0.9785	0.9681	0.9217

	Using all data		Fragment sizes >0.9 cm		Fragment sizes <0.9 cm	
%K <sub>2</sub> O	Mamatwan	Wessels	Mamatwan	Wessels	Mamatwan	Wessels
Alpha	0.5924	1.5935	1.9074	3.2555	-1.4073	0.9098
InK	-1.9669	1.9241	-2.6712	0.7511	-4.9057	1.1752
K	0.1399	6.8490	0.0692	2.1193	0.0074	3.2388
R2	0.1616	0.7693	0.3833	0.9263	0.6716	0.4324

	Using all data		Fragment sizes >0.9 cm		Fragment sizes <0.9 cm	
%P	Mamatwan	Wessels	Mamatwan	Wessels	Mamatwan	Wessels
Alpha	1.0313	1.6398	1.3531	2.7224	0.3383	0.8877
InK	-4.2327	-1.9716	-4.3457	-2.6852	-5.2401	-2.9487
K	0.0145	0.1392	0.0130	0.0682	0.0053	0.0524
R2	0.8058	0.8954	0.686	0.9118	0.2378	0.9047

	Using all data		Fragment sizes >0.9 cm		Fragment sizes <0.9 cm	
%SO <sub>2</sub>	Mamatwan	Wessels	Mamatwan	Wessels	Mamatwan	Wessels
Alpha	1.4878	2.005	1.7468	3.2856	0.672	1.2701
InK	0.1726	2.3553	0.1102	1.4585	-1.0715	1.4275
K	1.1884	10.5413	1.1165	4.2995	0.3425	4.1683
R2	0.8459	0.9241	0.6525	0.9751	0.6919	0.8693

Calibration curves indicate that for %Mn<sub>3</sub>O<sub>4</sub> and for %FeO the coarse fraction, above 0.9 cm, manganese ores have alpha values close to 3, whereas those less than 0.9 cm in diameter have alpha values closer to 1. Indications from the calibration curves shown in Figures 7 to 11 for elements under consideration are that Alpha ( $\alpha$ ) and K values are substantially changed indicating that the sampling nomogram for coarser grained materials (>0.9 cm) will be different from that for finer grained materials (<0.9 cm). Generally, the Wessels ores with an average K coefficient of 12.71, is about 9 times larger than that for Mamatwan ores (1.30), which will also significantly affect nomograms for the two ore types. A visual inspection of the calibration curves indicates a considerable improvement in the R<sup>2</sup> value for all the curves once the adjustments have been made to the data in the very smallest grain sizes, usually the 0.17 cm and 0.08 cm fractions.

### Compilation of the sampling nomograms

The values for K and Alpha derived from the modelled calibration curves for the elements %Mn<sub>3</sub>O<sub>4</sub>, %FeO, %K<sub>2</sub>O, %P, and %SO<sub>2</sub> are listed in Table 5. The intercept on the Y-axis in the calibration curves is transformed into the Intercept K using the exponent function; all calculations are carried out to four decimal places and rounded down to two. These data are used to compile the nomograms for cross-stream sampling of the ores, for the different elements considered for the Wessels and Mamatwan ores. Sampling nomograms for Mamatwan (upper panel) and Wessels (lower panel) ores for the elements %Mn<sub>3</sub>O<sub>4</sub>, %FeO, %K<sub>2</sub>O, %P, and %SO<sub>2</sub> are shown in Figures 12 to 16, (a and d) using all available data, (b and e) for coarse grained fragments > 0.90 cm, and (c and f) for fine-grained fragments < 0.90 cm. An example of the nomogram calculation using K, Alpha ( $\alpha$ ), lot mass, and fragments size, values which are substituted into Equation 1, is shown for the sample preparation nomogram and the improved nomogram in Table 6.

Table 6: An example of the sample nomogram and improved nomogram calculation for %Mn<sub>3</sub>O<sub>4</sub> in Mamatwan ores

Mamatwan	%Mn <sub>3</sub> O <sub>4</sub>	
Slope, Alpha=	2.24	
Intercept, K=	0.93	2.54

Sample Preparation Nomogram: %Mn <sub>3</sub> O <sub>4</sub>		
Mass (g)	Fragment size (cm)	Precision
24000.0	7.00	0.00827
24000.0	1.0000	0.00011
500.0	1.0000	0.00508
500.0	0.0075	0.00000
2.0	0.0075	0.00002

Improved Sample Nomogram: %Mn <sub>3</sub> O <sub>4</sub>		
Mass (g)	Fragment size (cm)	Precision
24000.0	2.00	0.00050
24000.0	0.5000	0.00002
500.0	0.5000	0.00108
500.0	0.0500	0.00001
2.0	0.0500	0.00155

Of the eighteen elements that were analysed in each sample calibration curves were only compiled for the elements %Mn<sub>3</sub>O<sub>4</sub>, %FeO, %K<sub>2</sub>O, %P, and %SO<sub>2</sub>, the first two being the main elements and the last three being the deleterious elements. These elements probably have reasonably stringent specification limits from an operational view point..

**Sample preparation protocol Mamatwan: Mn<sub>3</sub>O<sub>4</sub>**

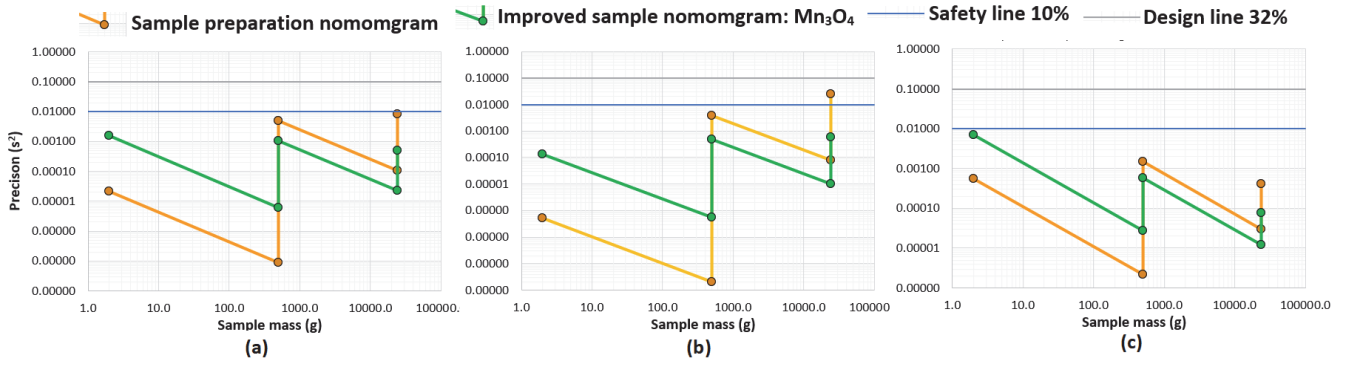

**Sample preparation protocol Wessels: Mn<sub>3</sub>O<sub>4</sub>**

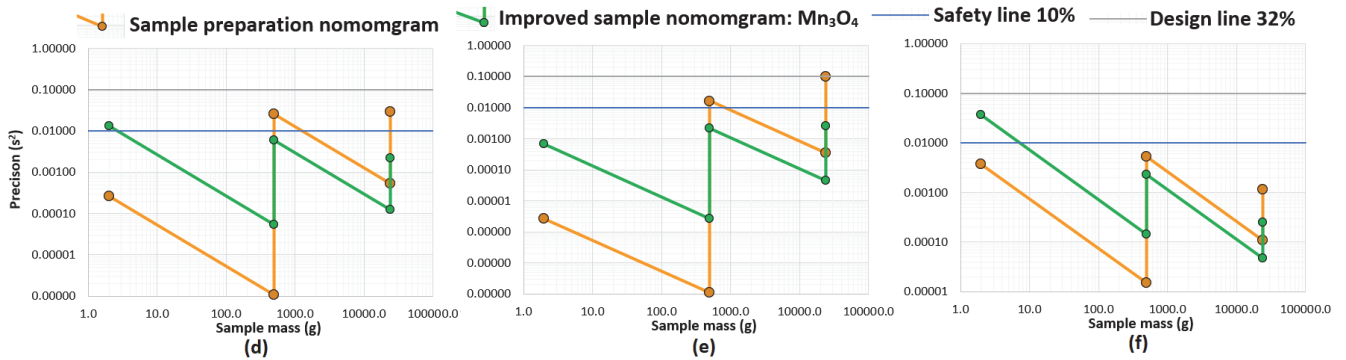
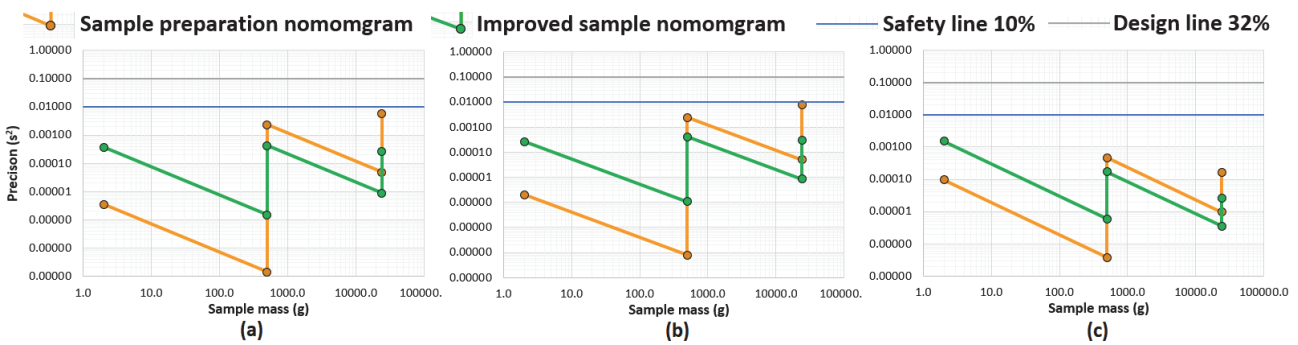

Figure 12: Sampling nomograms for Mamatwan (upper panel) and Wessels (lower panel) ores for the element %Mn<sub>3</sub>O<sub>4</sub> (a and d) using all available data, (b and e) for coarse grained fragments > 0.90 cm, and (c and f) for fine-grained fragments < 0.90 cm

**Sample preparation protocol Mamatwan: FeO**



**Sample preparation protocol Wessels: FeO**

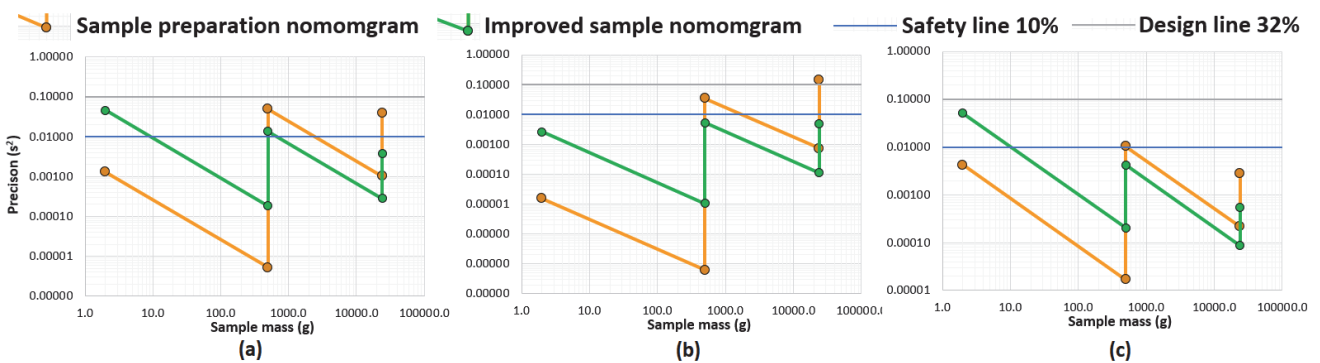
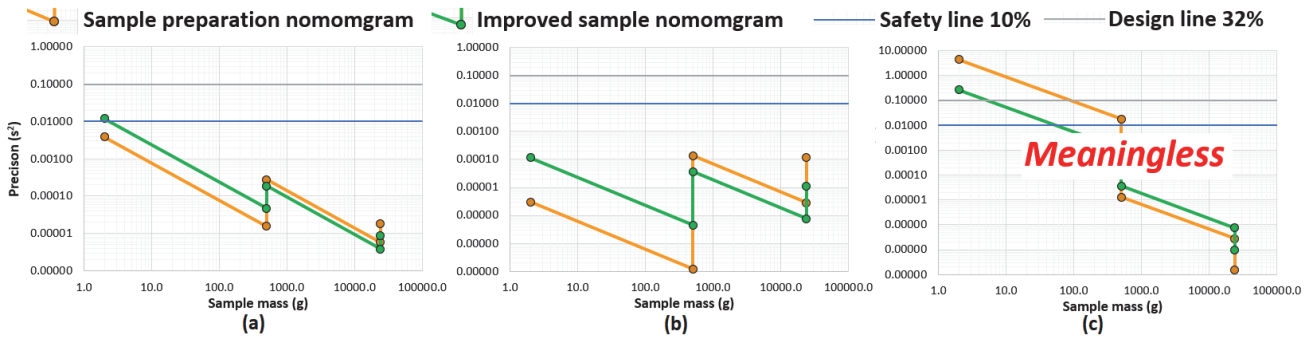

Figure 13: Sampling nomograms for Mamatwan (upper panel) and Wessels (lower panel) ores for the element %FeO (a and d) using all available data, (b and e) for coarse grained fragments > 0.90 cm, and (c and f) for fine-grained fragments < 0.90 cm

Sample preparation protocol Mamatwan: K<sub>2</sub>O



Sample preparation protocol Wessels: K<sub>2</sub>O

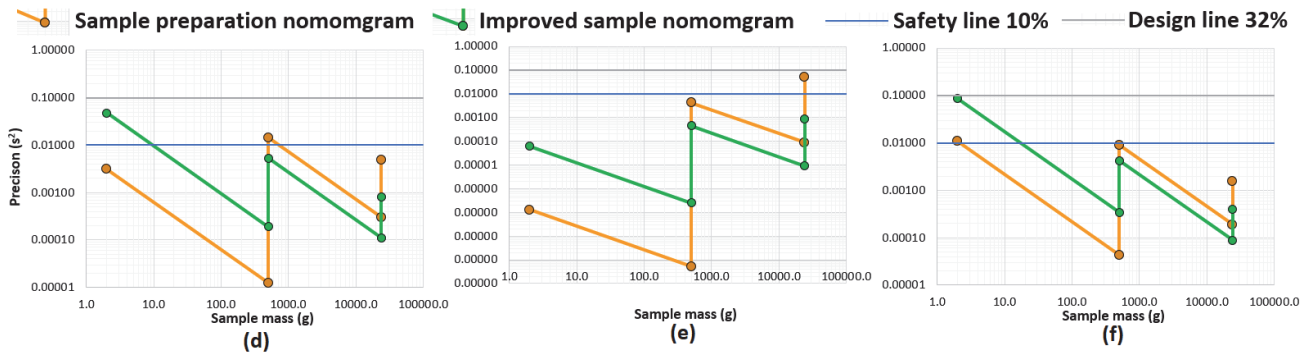
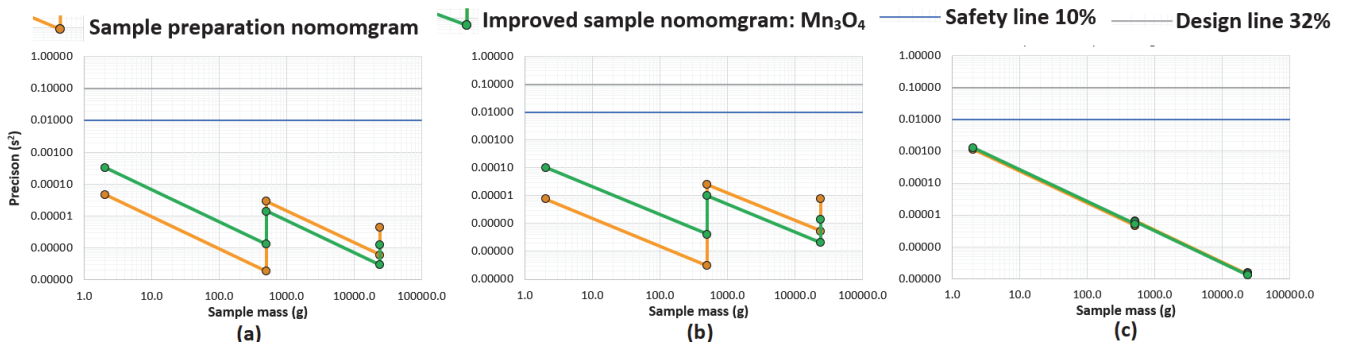

Figure 14: Sampling nomograms for Mamatwan (upper panel) and Wessels (lower panel) ores for the element %K<sub>2</sub>O (a and d) using all available data, (b and e) for coarse grained fragments > 0.90 cm, and (c and f) for fine-grained fragments < 0.90 cm

Sample preparation protocol Mamatwan: P



Sample preparation protocol Wessels: P

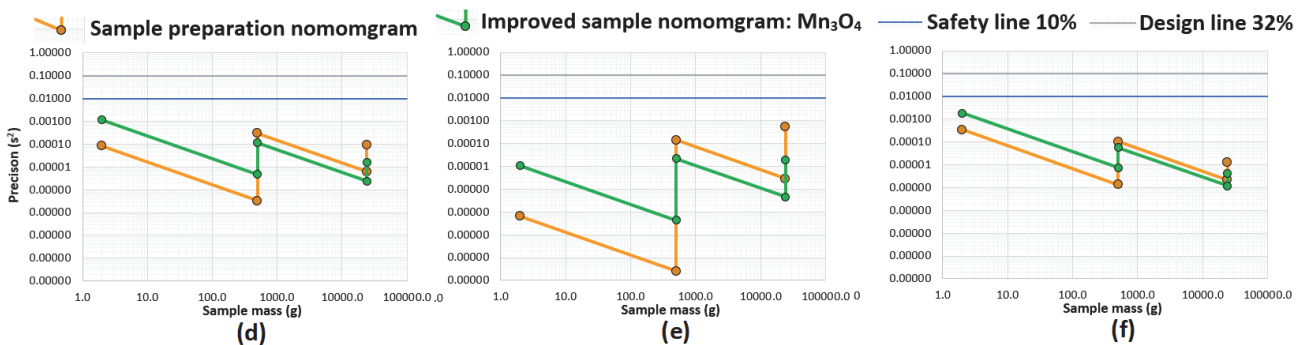

Figure 15: Sampling nomograms for Mamatwan (upper panel) and Wessels (lower panel) ores for the element %P (a and d) using all available data, (b and e) for coarse grained fragments > 0.90 cm, and (c and f) for fine-grained fragments

&lt; 0.90 cm

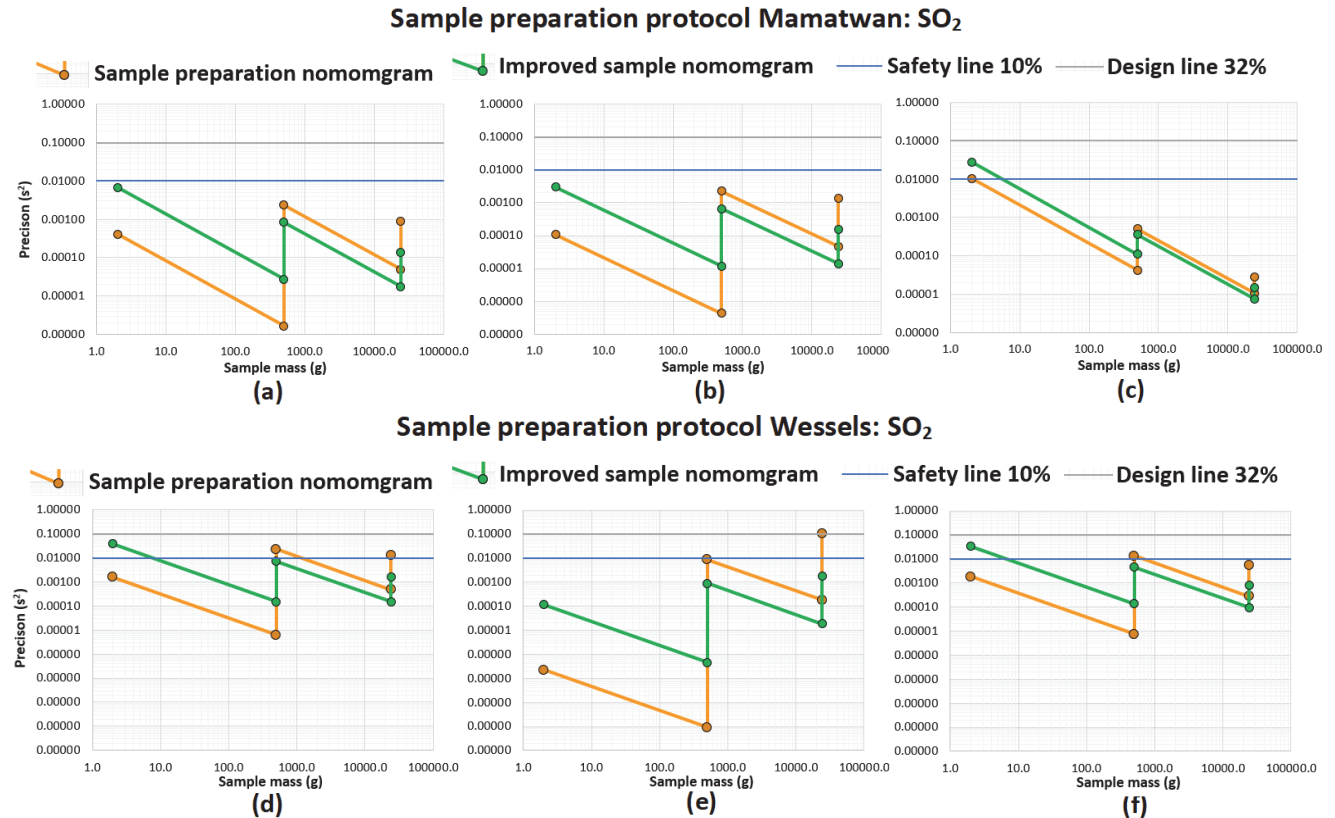

Figure 16: Sampling nomograms for Mamatwan (upper panel) and Wessels (lower panel) ores for the element %SO<sub>2</sub> (a and d) using all available data, (b and e) for coarse grained fragments > 0.90 cm, and (c and f) for fine-grained fragments < 0.90 cm

The sampling nomograms provide definitive steps for ensuring that the preparation of the sample, from lot to aliquot takes place in a way that does not violate the exacting principles of the FSE. Each nomogram shows what the stages of crushing and mass reduction will contribute to the overall precision of the FSE. Any step of the process in which the nomogram breaches the Safety Line (10% precision) or the Design Line (32% precision), should be changed to ensure that the nomogram remains consistently below these lines. In most cases the nomograms for the elements %Mn<sub>3</sub>O<sub>4</sub>, %FeO, %K<sub>2</sub>O, %P, and %SO<sub>2</sub> are well behaved for the coarser grained materials, namely those larger than 0.9 cm. By this it is meant that the overall trajectory of the nomogram for coarser grained materials is downwards to the left, whereas the trajectory for the nomograms of finer grained materials, below 0.9 cm, is upwards and to the left, meaning they are likely to require more careful attention when designing the sampling protocol. The nomogram for K<sub>2</sub>O in fine grained Mamatwan ores is meaningless because the Alpha value derived from the calibration curve shown in Figure 9c is negative at -1.4073. Thus, the nomogram cannot be created for these ores.

## Discussion and conclusions

In all the calibration curves, which should have plotted as straight lines, each element was found to have a distinctly flatter curve, in some cases even negative slopes, for materials in the finer size fractions, than for the coarser size fractions. The exact reasons for this behaviour are uncertain, but a number of reasons is suggested. The first and easiest suggestion is that it may be due to a preparation protocol in the laboratory that differed for the coarse and finer grained materials before the samples were analysed. However, one of the authors visited the laboratory to inspect the preparation protocol and has ensured that this was not the case. A second suggestion is that the distinct inflection in the calibration curves may be related to the behaviour of the crystal structure in the very pure ores as the ores are progressively milled to finer size fractions. It is possible that the component minerals, braunite, bixbyite, and psilomelane, all have different size characteristics with the dominant crystal size in the ores being about 0.9 cm. Above 0.9 cm the ores will be dominantly one ore type or another, but when the materials are crushed below 0.9 cm that the crystal structure is such that the different minerals are mixed and the behaviour of the variance for the 32 analyses is different to that for materials coarser than 0.9 cm. In all the elements analysed the Wessels ores have higher K coefficients than the Mamatwan ores; the alpha values for ores from the two mining operations are not dissimilar.

Net conclusions indicate that both Wessels and Mamatwan ores are relatively easy to sample and that simple two or three stage processing will suffice when preparing the final 2 g aliquot at 75 microns. Apart from minor modifications in the sample preparation protocols, there is no evidence to suggest that the Wessels and Mamatwan ores require different sample preparation protocols, or that they should be assayed differently. The calibration curves for manganese ore are compared with the calibration curves for gold bearing ores which generally have alpha values close to 1. The difference in alpha between the gold ores and bulk commodities is considered to be related to the primary distribution of the metals in nature, lognormal for gold and normal for manganese.

## References

1. P. M. Gy, "The sampling of broken ores – a general theory", in *Sampling Practices in the Mineral Industries Symposium*, Australian Institute of Mining and Metallurgy, Melbourne, September 16, 1976. 17p.
2. P. M. Gy, *Sampling of particulate materials*, Elsevier, Amsterdam. (1979).
3. P.M. Gy, *Sampling of Particulate Materials, Theory and Practice*, Elsevier. Amsterdam. 431. (1982).

4. P.M. Gy, *Sampling of Heterogeneous and Dynamic Material Systems: Theories of Heterogeneity, Sampling, and Homogenizing*, Elsevier Science Publishers B.V., Amsterdam, The Netherlands, (1992).
5. F.F. Pitard, "*Pierre Gy's sampling theory and sampling practice: heterogeneity, sampling correctness, and statistical process control*". CRC press, (1993)
6. F.F. Pitard, *Theory of Sampling and Sampling Practice*, third ed., CRC Press, Boca Raton, p. 691p. (2019)
7. K.H. Esbensen, "*Introduction to the Theory and Practice of Sampling*", IM Publications, Chichester, 2018, p. 327, <https://doi.org/10.1255/978-1-906715-29-8>. ISBN: 978-1-906715-29-8.
8. P. Thy, K.H. Esbensen and B.M. Jenkins, "On representative sampling and reliable chemical characterization in thermal biomass conversion studies", *Biomass Bioenerg.* **33**, 1513–1519 (2009).  
<https://doi.org/10.1016/j.biombioe.2009.07.015>
9. J.S. Dube, J.P. Boudreault, R. Bost, M. Sona, F. Duhaime, and Y. Ethier, "Representativeness of laboratory sampling procedures for the analysis of trace metals in soil", *Environ. Sci. Pollut. Control Ser.* **22** (15) 11862-11876, (2015) <https://doi.org/10.1007/s11356-015-4447-1>.
10. P.O. Minkkinen, K.H. Esbensen, "Sampling of particulate materials with significant spatial heterogeneity -theoretical modification of grouping and segregation factors involved with correct sampling errors: fundamental Sampling Error and Grouping and Segregation Error", *Anal. Chim. Acta* **1049**, 47-64. (2019).
11. C.H. Tai, S.S. Hsiau and C.A. Kruelle, "Density segregation in a vertically vibrated granular bed", *Powder Technology*, **204** 255–262. (2010)
12. R.C.A. Minnitt, P.M. Rice, C. Spangenberg, "Part 1: understanding the components of the fundamental sampling error: a key to good sampling practice", *J. S. Afr. Inst. Min. Metall.* **107**, 505-511. (2007a)
13. R.C.A. Minnitt, P.M. Rice, C. Spangenberg, "Part 2: experimental calibration of sampling parameters K and alpha for Gy's formula by the sampling tree method", *J. S. Afr. Inst. Min. Metall.* **107** 513-518. (2007b)
14. R.C.A. Minnitt, D. François-Bongarçon and F.F. Pitard, "Segregation Free Analysis for calibrating the constants K and alpha for use in Gy's formula", in: *WCSB 5 Sampling*. Santiago, Chile, 133-150. (2011)
15. R. Minnitt, "Calibrating K and alpha in Gy's formula: a new approach", *Math. Geosci.* **48**, 211-232. (2016)
16. D. Francois-Bongarçon, "Geostatistical determination of Sample Variances in the Sampling of Broken Gold Ores" *CIM Bulletin.* **84**(950), 46-57. (1991).
17. D. Francois-Bongarçon, "Geostatistical tools for the determination of Fundamental Sampling Variances and minimum sample masses". Kluwer Academic Pub. Dordrecht, The Netherlands. (1992).
18. D. Francois-Bongarçon, "The Practice of the Sampling of Broken Gold Ores" *CIM Bulletin.* **86**(970), 75-81. (1993).
19. D. François-Bongarçon, "Introduction and first ever rigorous derivation of the liberation factor", in: *Proc. 7th World Conference of Sampling and Blending (WCSB7)*, IM Publications, (165-168, 2015) <https://doi.org/10.1255/tosf.79>
20. M. Sona, J.-S. Dube, Sampling particulate matter for analysis – Controlling uncertainty and bias using the theory of sampling, *Anal. Chim. Acta* **1185** (2021), <https://doi.org/10.1016/j.aca.2021.338982>.
21. J.-S. Dube, M. Sona, J.-P. Boudreault, E. Hardy, Influence of particle size and grinding on measurement of trace metal concentration in urban anthropogenic soils, *J. Environ. Eng.* **140** (6) (2014), [https://doi.org/10.1061/\(ASCE\)EE.1943-7870.0000825](https://doi.org/10.1061/(ASCE)EE.1943-7870.0000825).

Appendix 1: %Mn<sub>3</sub>O<sub>4</sub> in 32 samples across the sample series at 15 different fragment sizes; other elements analysed include %FeO, %Al<sub>2</sub>O<sub>3</sub>, %CaO, %K<sub>2</sub>O, %P, and %SO<sub>2</sub> which are not reported here.

%Mn <sub>3</sub> O <sub>4</sub>	W1	W2	W3	W4	W5	W6	W7	W8	W9	W10	W11	W12	W13	W14	W15
<b>Frag size (cm)</b>	4.00	3.48	2.86	2.24	1.76	1.47	1.23	1.04	0.83	0.58	0.40	0.28	0.17	0.08	0.05
W1/1	37.05	68.41	76.28	61.05	61.22	65.27	63.05	65.30	64.05	64.36	65.28	64.67	64.13	64.04	62.79
W1/2	74.72	65.38	66.03	61.57	64.69	63.94	63.53	62.96	63.98	64.17	64.52	64.26	64.59	64.25	62.44
W1/3	72.78	67.04	71.58	62.43	62.97	64.26	62.76	63.43	63.14	64.19	64.95	65.00	64.30	64.14	62.46
W1/4	76.14	70.65	72.22	63.57	66.37	63.70	64.50	64.36	64.17	64.95	64.54	64.95	65.03	64.10	62.79
W1/5	59.52	74.30	66.05	61.65	63.22	65.96	66.60	64.44	65.70	65.21	64.38	64.81	64.31	64.66	62.45
W1/6	68.92	57.18	63.49	70.32	63.83	63.54	65.97	65.07	65.46	64.67	64.05	63.99	64.03	64.24	62.34
W1/7	58.21	69.35	68.88	67.15	64.36	62.71	62.95	61.42	65.44	63.31	64.09	64.83	64.27	63.85	62.75
W1/8	63.03	62.22	71.01	61.60	63.56	63.17	66.85	67.38	63.23	63.74	63.82	64.05	64.25	63.83	62.92
W1/9	58.72	65.97	64.11	64.94	67.47	65.10	63.86	65.76	64.90	65.46	64.20	64.73	64.18	63.44	62.70
W1/10	69.16	60.31	56.89	63.21	64.90	64.99	64.79	65.25	65.33	64.74	64.67	64.55	64.09	63.72	62.72
W1/11	63.35	73.71	65.70	65.18	65.97	66.18	65.68	66.75	66.85	64.74	64.49	64.37	64.66	64.08	62.55
W1/12	63.05	45.43	60.52	60.61	62.89	64.58	65.54	64.55	64.63	65.10	64.75	64.46	64.22	64.21	62.59
W1/13	67.11	67.27	69.83	70.30	67.53	63.72	66.13	63.80	64.61	65.29	64.38	64.85	63.64	64.11	62.30
W1/14	64.14	63.13	68.45	62.54	69.01	70.23	63.46	62.42	63.85	64.77	64.23	64.65	63.95	63.82	62.41
W1/15	72.47	61.37	71.08	62.21	65.75	67.43	64.55	62.93	63.94	64.61	63.50	64.49	64.09	63.84	62.22
W1/16	63.14	64.54	70.67	64.08	65.55	65.38	67.69	64.65	64.82	63.67	64.66	65.30	63.96	63.88	62.28
W1/17	73.98	69.98	61.75	63.34	66.16	63.90	64.25	64.96	63.32	64.25	64.65	64.58	64.54	63.95	62.36
W1/18	71.84	65.33	71.04	65.79	63.16	63.98	64.33	65.34	64.93	64.34	64.46	64.85	64.02	64.05	62.54
W1/19	67.68	69.92	70.35	65.26	61.36	65.41	63.82	64.32	62.74	64.37	64.54	64.27	64.23	63.95	62.41
W1/20	68.19	72.20	66.21	69.28	64.13	64.09	64.60	66.19	64.61	64.22	64.48	64.85	64.16	63.92	62.42
W1/21	51.12	73.05	67.32	65.88	62.46	67.20	64.86	64.10	64.26	64.65	65.37	64.42	64.51	63.66	62.97
W1/22	70.92	71.58	67.24	69.06	63.28	64.68	64.65	62.76	64.06	63.63	64.20	64.30	64.58	64.13	62.37
W1/23	63.71	60.64	66.62	65.40	62.20	64.67	66.05	65.40	65.10	64.65	64.50	64.90	64.25	63.94	62.52
W1/24	54.12	59.97	60.22	61.19	64.62	63.54	64.28	62.63	64.25	64.40	64.85	65.25	64.55	63.74	62.76
W1/25	72.39	66.75	71.92	70.57	61.13	61.35	64.00	63.69	62.31	64.21	65.11	64.87	64.23	64.25	62.30
W1/26	69.30	64.60	62.44	65.70	63.55	63.96	64.68	64.35	65.84	64.09	64.07	64.83	64.36	64.16	62.50
W1/27	71.56	64.47	64.53	67.39	64.43	65.73	66.43	62.88	65.84	64.65	64.91	64.90	64.26	64.09	62.07
W1/28	50.53	71.44	64.73	58.02	60.32	67.27	65.03	64.43	62.34	64.63	65.54	65.04	64.35	63.85	62.48
W1/29	71.18	69.16	67.51	63.15	64.10	66.80	63.71	64.99	64.22	64.56	64.90	64.55	63.92	63.80	62.65
W1/30	72.30	60.16	64.39	65.85	59.81	65.26	66.00	64.56	65.42	63.57	64.15	64.14	64.61	63.89	62.33
W1/31	68.98	66.95	68.41	63.95	66.09	67.03	63.28	64.96	62.12	64.90	64.06	64.30	65.06	63.84	62.42
W1/32	66.10	54.03	67.53	64.59	64.10	68.44	65.17	65.26	63.62	63.85	65.52	64.91	64.72	64.48	62.27
<b>Average Mass</b>	585.25	566.5	554.5	532.5	545.5	471.25	421	378.25	371.25	393.5	294.25	307.75	156.75	116	163.5





## Proactive Rolling Bias Test applied on Sample Stations

D. Johnson<sup>a</sup>, J. Kelly<sup>b</sup> and O. Dominguez<sup>c</sup>

<sup>a</sup>Mackay Region Manager, ALS Coal, 5 John Vella Drive, Paget, QLD, 4740. E-mail: [daniel.johnson@alsglobal.com](mailto:daniel.johnson@alsglobal.com)

<sup>b</sup>Geometallurgist, BHP Mitsubishi Alliance (BMA), 480 Queen Street, Brisbane, QLD, 4000. E-mail: [john.i.kelly@bhp.com](mailto:john.i.kelly@bhp.com)

<sup>c</sup>Global Principal QAQC, BHP Geoscience Centre of Excellence, L33, 125 St Georges Tce, Perth, WA, 6000.

E-mail: [oscar.r.dominguez@bhp.com](mailto:oscar.r.dominguez@bhp.com)

The most basic concept of sampling theory is that “a sample is part of a lot”, where the sample collected needs to be representative to the lot sampled. On sample stations, the lot to be sampled is represented by the material transported by the conveyor belt, while the sample is collected and further subsampled via cutters until the final sample collection point.

Current normal practices to evaluate the operation of sample stations that support processing, metallurgical balance, reconciliation, and final port shipments are typically based on visual inspections: Material build-up on cutters, sample spillage, reflux while sampling, pegging on sizing screens, worn cutter lips are all observations that indicate issues. Being subjective observations, these do not allow the quantification of the sample’s representivity, and the risks for mining businesses due to a positive or negative bias being incorporated during sample collection stage.

Bias Tests are mentioned in several International Standards across commodities (ISO3082 for Iron, ISO 13909-8 for Coal and ISO12743 for Copper, Lead, Zinc and Nickel, for example) to compare the sample obtained against the material it is supposed to represent at the control point. The current methodology and strategy used in the industry requires the interruption of the regular production process multiple times in a row for extended periods of time, to manually extract the material from the conveyor belt (also including manual handling and safety considerations). For this reason, bias tests are not very popular in industry (“we lose a lot of money and time having to interrupt our process many times”) - and are therefore usually performed only very reluctantly, or not at all, exposing mining companies to higher production and financial risks than necessary, hence it is simply assumed that the processes involved are not affected by bias.

This paper is presenting a proactive approach to perform a Bias Test, developed at Hay Point Port Coal, a Rolling Bias concept has been developed, switching the current reactive, time consuming and manual process task, to a more proactive and frequent methodology that allows for trending analysis of the sample station. Quarterly planned maintenance stops are used to perform the bias test, where a vacuum system developed and tested by ALS Laboratory and BHP Coal, performs the collection of the material from the conveyor belt drastically reducing the time required to perform the task manually, but more importantly reducing the exposure of people to safety and manual handling risks. This approach enables Hay Point Port to have quarterly performance data of the sample station, converting this process to a more objective, proactive, and sustainable approach where data, every quarter, has been monitored since 2019.

### Introduction

Bias tests are performed to assess and quantify potential levels of bias present on sample stations, normally located on processing plants and ports. In this process, a belt is stopped and a representative reference sample is collected from the material on the belt (the lot). The belt is restarted, and next to the reference just collected, a normal sample going all through the sample station (primary cutter, secondary cutter, etc), is obtained by the sample plant. Both samples are analysed to determine if there is bias in the sample plant. A number of paired samples are required to achieve a statistically valid indication of bias. It is important to note that the method used to collect the representative reference sample must be in itself unbiased in order that this sample is suitable for use as a reference sample.

Bias tests are mentioned within ISO requirements in different commodities (ISO3082 for Iron, ISO 13909-8 for Coal and ISO12743 for Copper, Lead, Zinc and Nickel, for example), but current industry strategy is to perform it just once every several years, if at all after initial commissioning.

In this setting, when bias tests are performed, it is a reactive response as a part of an investigation into a significant deviation in observed results. A reactive approach to understanding bias in a sample plant is poor practice and increases the risk that key quality parameters will drift outside of required specifications. This will ultimately lead to higher production and financial risks.

As a consequence of this reactive strategy and the interruptions in operations, bias tests unfortunately are not normally performed as a part of a routine schedule. To provide some control on the sampling operations, sample plants are typically monitored by visual inspections and the online monitoring of basic parameters. These subjective inspections often provide a “false sense of confidence” to operations that the sampling processes bias are working within specifications, even though they may have already failed in the quality quantification. In addition, where differences arise on reconciliation results, the quality of sample stations data (in the absent of bias test) can be considered as unknown, impacting directly the timeframe of investigation and making the impacts of the production deviations bigger.

A proactive rolling bias testing process can be continuously implemented to reduce the immediate impact on operations, this process allows for a small subset of samples, normally around 2-4, to be collected at each sampling time and be added to a data set up to the required number of samples to achieve statistical significance. Statistical significance varies with the material being tested, being primarily dependent on the homogeneity of the material.

## Methodology – reactive vs proactive rolling bias tests

As per ISO requirements in different commodities, a stopped-belt sampling bias test is the accepted method to obtain a reference sample (from the lot) against which other sampling procedures may be compared (e.g. ISO3082). The frequency at which samples are collected in a rolling bias test is determined based of the requirements of the site and the perceived risk level. Rolling Bias testing would normally be completed on a quarterly or half yearly schedule. However, this process can be completed at a much higher frequency and more proactively if monitoring at such a level is deemed necessary. Conversely, extending a rolling bias sample program out beyond half yearly sampling intervals will significantly reduce the usefulness of this practice.

Changing the current industry reactive approach for a more proactive approach, samples are continuously collected to allow a robust statistical analysis, but importantly shifting the current investigation framework, normally performed at the start, by providing the opportunity to perform more trend analysis over period of times. In this way bias testing can be completed regularly and with minimal disruption to maintain assurance that the sample plants are objectively free from bias. It is important to note that before conducting any form of bias testing a thorough compliance audit of the sampling system is completed and any issues of concern are rectified. Otherwise, any significant error in the operation of the plant will almost certainly cause bias which will result in the bias testing being a waste of time and resources.

ALS’s Mackay Coal Laboratory and BMA’s Hay Point Coal Terminal have been collaborating for several years to develop the current rolling bias test process used at the terminal. This has resulted in a number of innovations that have been developed to ensure that the process is able to be completed with minimal disruption to the throughput of the terminal. The three major innovations are:

- The implementation of a rolling bias test program that minimises disruption to throughput at the terminal and where all the stakeholders in the supply chain are informed and aligned.
- A dedicated bias test mode was developed for the sample plants to automate the collection of the routine sample and ensure that the routine sample cut is all that comes through the plant until it is returned to normal operation. This also means the plant is operating in a “normal” way. Without this mode sample plants need to be operated in “manual” so that the primary cut can be triggered, and the system will process the sample, this leads to unusual operation in some plants as systems that sense and react are often disabled or ignored in manual operation.
- A vacuum system has been developed to replace normal manual methodology, allowing for rapid sample collection. This system allows for significant volumes of sample to be collected in a short period of time and minimises the health and safety risks associated with manual handling. Finally, the vacuum system eliminates the need for samplers to be on the belt itself.

## Methodology – manual methodology versus vacuum system

### Current manual methodology

Normally when collecting stop belt samples, the belt is stopped, and the system is isolated. Then a sample frame is driven into the material to the surface of the belt and the sample is shovelled and swept out of the frame. A sampling frame is utilised to ensure that only the material in the selected section of belt is collected and no additional material from the edges of the cut can fall into the sample being collected. This sample is then taken to the sample collection drums in buckets. Once this is completed the sample frame is removed and the system is de-isolated. This process requires significant quantities of labour and time, all the while exposing the people involved to significant manual handling risks. Also, depending on various factors at the site, this process can require a significant number of people to complete the sampling safely and efficiently.

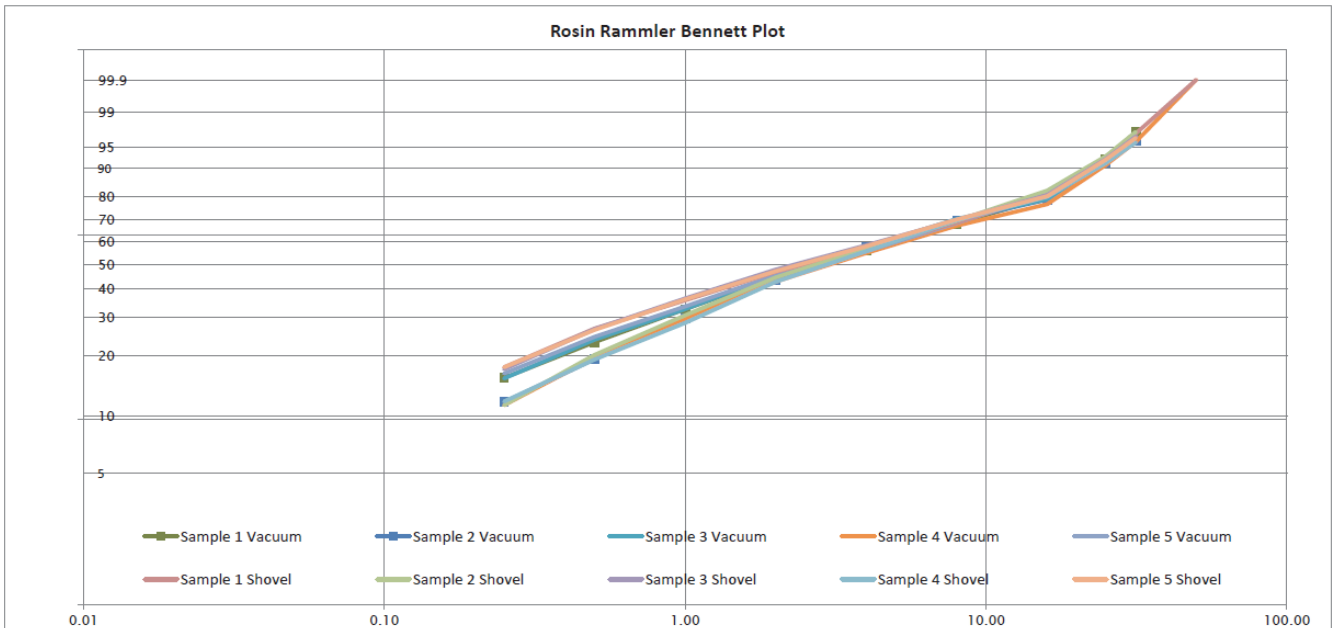

**Figure 1. Traditional Stopped belt sampling.**

Vacuum system

One of the key processes used to reduce the impact to the operation during the sampling for bias testing is the use of the vacuum system, where the reference sample is collected by using a validated vacuum system replacing the current manual task which drastically minimises the stoppage time. The stoppage time will vary across sites largely due to variances in time it takes to isolate and deisolate the systems. At Hay Point Coal terminal, the stoppage time requires 10-20 mins per reference sample with the majority of that time consumed with isolation and deisolation processes. This also only requires a maximum of 2 people for sample collection. The reference sample (full grain size distribution) is rapidly vacuumed off the belt and deposited directly into the drum through an annulus on the top of the drum.

Part of the development process for the use of the vacuum system was to run a series of tests comparing the results of traditional sampling with the results achieved using the vacuum system. This test work provided confidence that the vacuum system itself was collecting representative samples. During this process there was also a series of comparison samples taken utilising a sampling frame and without a sampling frame, this series of tests established no significant variance between the two practices and the process was determined to be acceptable to move forward without the use of a sampling frame. By using the vacuum system and not having samplers on the belt there is minimal disturbance to the sides of the of the sample cut. For this approach to be used on different commodities/sites similar test work to determine the suitability of the vacuum system and sample collection without a sampling frame would be recommended to be completed.



**Figure 2. Vacuum trial size distribution comparison plot.**



**Figure 3. Belt sampling using the vacuum system.**

The basic process for sampling using the vacuum system is as follows:

- Upon arrival, and having completed all access requirements for site, the vacuum is moved down to the belt to be sampled and the area is reviewed for safe access and any potential issues. The sample plant is also reviewed for safe access and any issues.
- If a previous Job Safety and Environmental Analysis (JSEA) / Workplace Risk Assessment and Control (WRAC) exists this document is reviewed by the persons conducting the work and any changes required due to changed conditions/processes are documented and implemented. If there is not an existing document this process will be completed.
- The vacuum is moved into position for the sample collection or as close as can be achieved prior to isolation.
- After confirming with control, or other responsible party, the belt will be stopped, usually by means of the pull cord, to achieve an immediate stop. This is organised in such a way that the loading on the belt is appropriate when it is stopped.
- The sampling personnel then isolate the belt and complete any other isolations that may be required.
- The vacuum is then positioned into its operational position.
- The operator positions the hose and vacuum head at the point of the manual cut, and the vacuum is started collecting an area of 3 times the nominal top size, as per ISO requirements as a minimum. The sample collected needs to comply with Theory of Sampling (TOS) requirements by including the full material in the conveyor belt (full grain size distribution) and not having preferential trends. This sample collected is considered under ISO as the reference, in other words, as representative to the lot to be sampled by the sample station.
- The operator then vacuums the sample, leaving the belt clean, and the sample is collected into a clean 205l drum located on the ground below the vacuum system.
- The vacuum equipment, and vacuum if required, are moved from the belt area and the belt is de-isolated and returned to operation.
- The sample plant is set up/prepared so that the sample from the matching Primary cut is the only sample collected at the sample collection point while the belt sample collection is taking place.
- If the sample plant is not set up with a Bias Test Mode, the cut position on the belt will be marked and the primary cutter will be manually triggered to try to achieve a cut as close as possible to the manual cut. If Bias test mode exists, the plant will be placed into this mode while the belt is stopped.
- The plant is then allowed to process the sample as normal and the final sample is collected from the nominated point (usually the final sample collection point but this can vary due to operational, access and safety requirements).
- Usually at least a second sample is collected. However, at the beginning of the program usually four samples are targeted to build the dataset rapidly. The second and subsequent samples are obtained by repeating the sampling processes as many times as required.
- The collected samples are returned to the laboratory for the analysis of the predetermined critical parameters and a basic review of the completed data set is undertaken to indicate if bias is likely to be present.
- Once there a sufficient number of data points are obtained a more robust statistical analysis of the results this is completed. This provides greater confidence in the determination of any bias.

### Advantages for a proactive rolling bias test approach

There are several advantages to performing a rolling bias test as compared to a standard bias test. Downtime and interruptions to production are minimised due to the limited number of samples that are collected each time sample collection is scheduled. This practice also helps to ensure ongoing monitoring (trend analysis) of potential bias as samples are being regularly collected and analysis of results is completed as soon as possible after collection. This ensures that if bias begins to present itself in the data set it can be actioned before it becomes a significant deviation and presents commercial issues.

The more traditional approach of campaign sampling and only conducting bias testing when deemed absolutely necessary cannot identify issues until well after they have arisen and usually not until after the bias present has caused commercial issues.

For example, and as a context, Holmes (2021) quantified in US\$23 M the potential value loss for just a 0.1% Fe bias in an iron ore mine exporting in a year 250 Mt...so any minor source of bias is having a big impact for businesses.

Sampling Date	Reference Sample Mass	Non-Reference Sample Mass	Reference Increment (Ri)	Non-reference increment (Ai)	Difference
	(kg)	(kg)	Ash (%)	Ash (%)	(Di = Ai - Ri) (%)
24/05/2019	147.28	2.309	11.15	11.20	0.05
24/05/2019	138.48	2.468	11.23	11.83	0.60
24/05/2019	149.06	2.437	10.57	10.52	-0.05
23/08/2019	162.22	3.678	10.15	10.37	0.22
23/08/2019	162.78	2.234	9.89	9.89	0.00
23/08/2019	146.32	2.868	9.72	9.30	-0.42
17/10/2019	133.50	3.304	8.58	8.59	0.01
17/10/2019	87.56	3.598	8.98	8.59	-0.39
17/10/2019	142.52	3.811	8.88	9.29	0.41
17/10/2019	155.84	4.012	8.78	8.48	-0.30
19/12/2019	134.02	2.642	10.02	9.93	-0.09
19/12/2019	138.46	2.160	10.92	10.73	-0.19
19/12/2019	140.25	2.280	10.82	10.92	0.10
6/03/2020	123.32	2.484	7.90	8.31	0.41
6/03/2020	169.74	1.318	9.03	9.02	-0.01
6/03/2020	176.40	2.395	8.61	8.72	0.11
21/05/2020	165.22	3.390	9.50	9.20	-0.30
21/05/2020	169.58	3.396	9.20	9.10	-0.10
21/05/2020	153.42	3.606	9.32	9.11	-0.21
19/08/2020	135.62	2.247	9.60	10.09	0.49
19/08/2020	157.90	2.138	9.20	8.99	-0.21
19/08/2020	112.20	3.590	10.99	10.60	-0.39
19/08/2020	145.94	2.404	9.49	9.59	0.10
27/10/2020	177.12	3.200	9.90	9.80	-0.10
11/03/2021	172.40	2.578	8.78	8.88	0.10
11/03/2021	181.04	3.154	8.60	8.74	0.14
9/09/2021	159.36	2.478	8.97	9.52	0.55
9/09/2021	173.50	2.894	9.26	9.34	0.08
10/12/2021	162.80	2.160	8.92	8.80	-0.12
10/12/2021	167.88	1.962	8.72	8.80	0.08
30	Rolling Mean		9.52	9.54	0.02
	Rolling Standard Deviation				0.27

Figure 4. Example results.

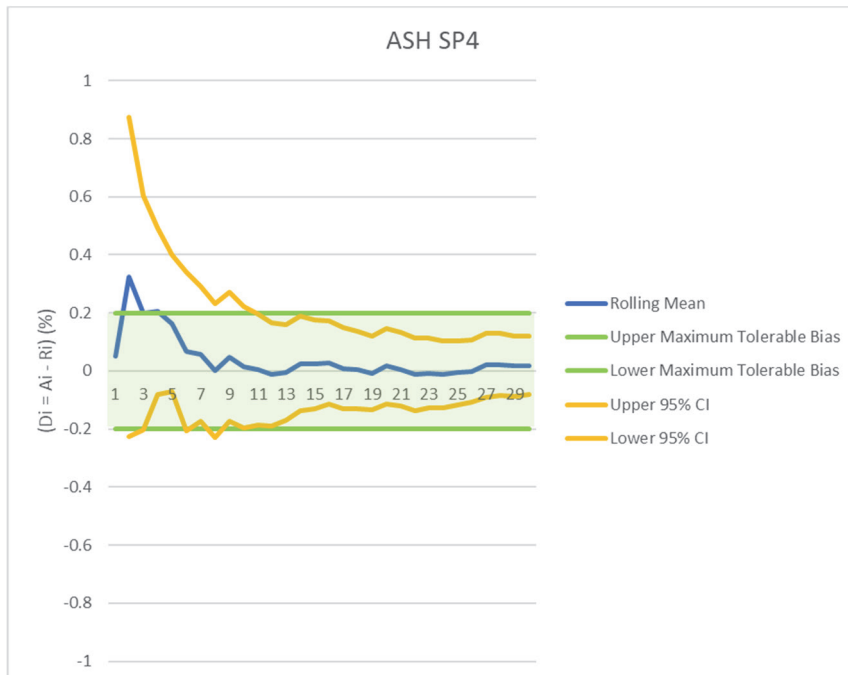

Figure 5. Example results plot.

## Conclusion

Even though the requirement for Bias Tests are included in ISO Standards for several commodities, normally they are not performed due to the impact to production due to the downtime required to manually collect reference samples from conveyor belts that need to be stopped frequently.

Current industry approach for Bias Tests is reactive and subjective, because they are performed when issues have been already impacted production results, and because current subjective inspections cannot quantify the quality of the samples collected.

Rolling bias testing presented in this paper is a low cost, pragmatic and time effective process to manage bias in sample plants. Changing the strategy toward a more frequent sampling plan and by utilising the vacuum collection process serves to further drive down time taken for sample collection and costs involved with sampling. It balances the need to regularly monitor bias in the sample plant with the need to maintain throughput/production. The process is applicable to most bulk solids including coal, iron ore, mineral concentrates and can be completed with minimal disruption to site. Processes developed in collaboration between ALS and BHP are easily used, are readily transferable and, while there will be a certain limited amount of set up work required for each site, this process can be implemented rapidly and improved upon over time as site needs are better understood and local processes developed.

Overall rolling bias testing utilising the vacuum system:

- Significantly reduces manual handling and risks associated with mounting belts,
- Significantly reduces downtime,
- Can be planned and loaded into site maintenance systems,
- Provides proactive quality assurance/review of the sampling system, and
- Is suitable for most bulk solids.

## ORCID iDs

D. Johnson: <https://orcid.org/0000-0003-1520-1772>

J. Kelly: <https://orcid.org/0000-0002-7937-9441>

O. Dominguez:

## References

1. ISO 13909-8, "Hard coal and coke Mechanical sampling part 8: Methods for testing for bias".
2. ISO 3082, "Iron ores – Sampling and sample preparation procedures".
3. R. Holmes "Incorrect sampling practices always have significant economic consequences – and never more so than where tonnages are large", *Spectroscopy Europe*, vol 33, October 2021.

## Extensions to the Theory of Sampling 2. The Sampling Uncertainty (SU), and SU as alternative to variographic analysis

Bo Svensmark

Department of Plant and Environmental Sciences, University of Copenhagen, Faculty of Science, Thorvaldsensvej 40, DK-1871, Frederiksberg C, Denmark, E-mail: [svensmark@plen.ku.dk](mailto:svensmark@plen.ku.dk)

**In the Theory of Sampling the Grouping and Segregation Error (GSE) is expressed relative to the Fundamental Sampling Error (FSE) by  $GSE = Y \cdot Z \cdot FSE$ . Unfortunately, estimation of  $Z$  seems difficult or impossible. The problem seems to be the attempt to link GSE to FSE. However, the sampling uncertainty due to FSE + GSE can be estimated from the distributional heterogeneity, with a small modification, by a new function, the Sampling Uncertainty (SU) proposed here. SU is calculated from the spatial distribution of the analyte in a manner similar to cyclic convolution. The new method was validated by a riffle splitter mass reduction experiment and by variographic analysis of theoretical data. For 1-dimensional sampling SU is shown to be better than variogram integration in case of cyclic or non-stationary variations and by being independent of the nugget effect when the nugget effect is close to zero. Thus, the extensions allow accurate predictions of the correct sampling uncertainty for 1-dimensional sampling and are proposed as a supplement to variographic analysis. The rationale for using SU is to be able to set up plausible theoretical scenarios for a sampling problem, and to predict the effect of variations in sample size, increment number, increment orientation and sampling method (random systematic, stratified random, random or single increment sampling). SU can also give numeric results for 2-dimensional sampling. The use of SU will mainly be for teaching and for a quantitative understanding of Theory of Sampling and of the benefits of compositional sampling.**

### Introduction

According to Theory of Sampling (TOS) as developed by Pierre Gy, a representative sample has an acceptable (for the intended use) bias and precision, and bias can be minimized by taking the sample correctly according to the Fundamental Sampling Principle [1-3]. When that is the case, sampling precision is given by FSE and GSE alone, where the latter is often much higher than the former and in practice is responsible for most of the sampling variance. Minkinen [4] has estimated the effects of GSE on simulated lots and Minkinen and Esbensen [5] have made important work with a modification of the factors used for GSE. Unfortunately it is difficult to use the present theory to predict the sampling variance due to GSE, as shown by Geelhoed [6], see Supplementary materials S1 in [14]. A theoretical solution to this is proposed here.

The Sampling Uncertainty (SU) proposed here is a method for estimation of the relative standard deviation for a specific sampling protocol, where a sampling protocol includes sampling method (single increment, random systematic, stratified random or random sampling), number of increments, sampling ratio (mass of the sample divided by mass of the lot), and the specific orientation of the increments relative to the segregation in the lot. Thus SU depends on the combined properties of the lot and of the sampling process. For the lot, input data are spatial distributions of fragments or analytes, which in most cases are not known beforehand, but it is often possible to set up realistic scenarios with reasonable distributions based on prior knowledge or in parallel to similar cases.

So what can it be used for? SU is very well suited for pedagogical purposes, because all aspects of grouping and segregation and distributional heterogeneity can be simulated with greater accuracy, e.g. to show the benefits of composite sampling by real numbers. In a teaching environment it is also possible to make practical experiments with lots which have been prepared with well known properties [7]. But SU can also estimate sampling errors for 1-dimensional (and higher dimensional) cases in the same way as variographic analysis, i.e. the results are estimated based on a series of real samples, and in such cases concentrations are known as function of position. In other cases, e.g. for preparing a series of secondary samplings, it is also possible to make a first sampling round to estimate the distribution of analytes and/or fragments, and then to use SU to make the best protocol for the following many samples. So for many practical cases SU allows a quantitative comparison of different sampling schemes and a better-informed selection of the best compromise between precision and 'cost'.

In most cases SU will be a prediction of the Grouping and Segregation Error (GSE) because the input for the calculations does only contain average concentrations. In other cases, when the input are data from real samples like samples for variographic analysis, the data are affected by the Fundamental Sampling Error (FSE) and long range errors in addition to GSE, so the result from SU will be estimates of the Correct Sampling Error. This double meaning is the main reason for choosing a separate name for this function: SU is the result obtained by Eq. (3) proposed here, i.e. it is an estimate which can be compared to or predict real sampling errors.



### Theory

Two new functions, the Sampling Uncertainty SU proposed here, and the Fundamental Sampling Uncertainty FSU [7], allow estimation of the effect of segregation on sampling errors from theoretical or experimental data.

#### The Sampling Uncertainty SU

The Sampling Uncertainty SU is calculated in a manner parallel to the calculation of the distributional heterogeneity  $DH_L$ . The only difference is that the groups for SU are all the potential samples, that can be taken from the lot by a given sampling protocol, while the groups for the distributional heterogeneity are all the potential increments that is needed to sample the whole lot. The difference in the results is that  $DH_L$  is characteristic of the lot, but only depends on the size of an increment, thus the other characteristics of the sampling protocol are not included and accordingly sampling errors cannot be predicted. In SU all characteristics of the lot and the sampling protocol are included and sampling error can be predicted (from theoretic data) or estimated (from previous samplings like in variographic analysis), with an accuracy equal to that of the input data.

This treatment will start with a situation such as a riffle splitter where the lot is 3-dimensional (X, Y, Z), but one dimension Y is sampled in its entirety. Assume that the concentration in the X-direction along the input tray perpendicular to the chutes are known for all  $x_{max}$  positions.

To explain the concept of the “potential samples”, look at the simplest example, a vertical sample with increments, taken from top to bottom of the lot, as shown in Fig. 1. The increments could be taken at all positions in the horizontal direction as indicated by the white arrow in the figure.

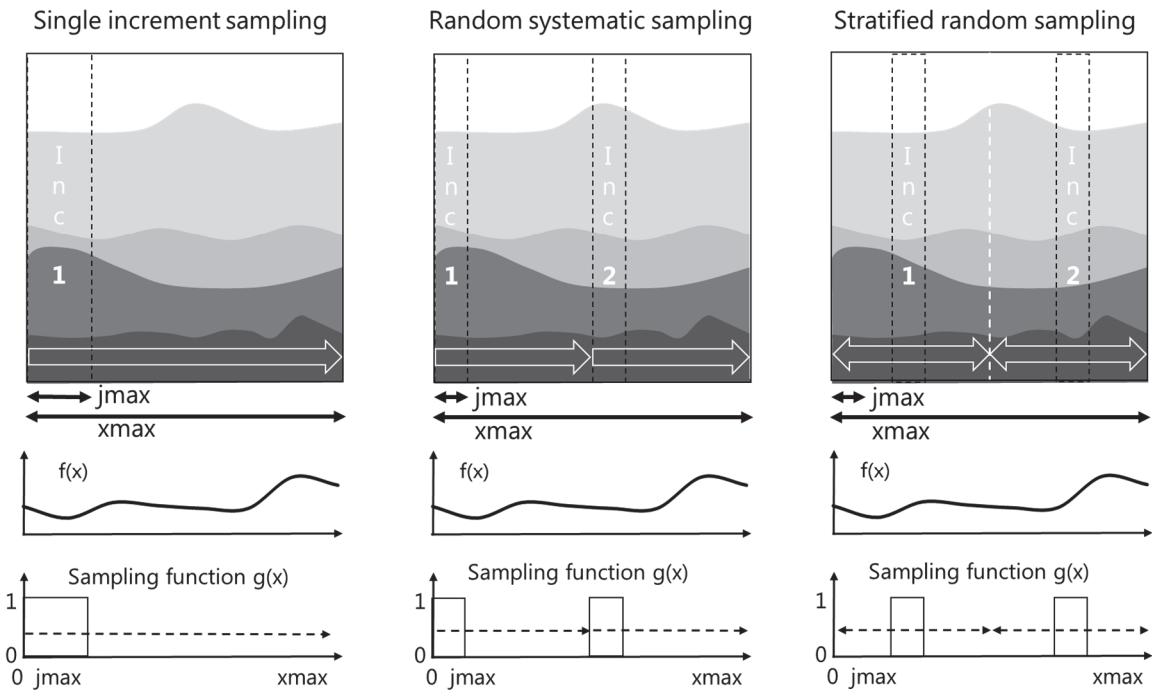

**Figure 1. Sampling with 2 increments of width  $j_{max}$  taken from a lot of width  $x_{max}$ .  $f(x)$  is the concentration as function of position and  $g(x)$  is the sampling function.**

The single increment sample consists of one increment that could be taken at any position within the lot. The 2 increments in the random systematic sample are synchronized, so the distance between them will always be constant. For stratified random sampling the 2 increments could be taken at any position within half of the lot. For random sampling all increments can be taken from all parts of the lot as long as they do not overlap.

The concentration  $a_i$  in a potential samples starting at index  $i$  can be obtained as a simple sum:

Potential samples: 
$$a_i = \frac{1}{ni \cdot j_{max}} \sum_{l=1}^{l=ni} \sum_{j=1}^{j_{max}} a_{i+j-1+(l-1)h} \quad \text{for } i = 1 \text{ to } h \quad (1)$$

- $i$ : Start position of the first increment
- $j_{max}$ : Width of one increment,  $j_{max} = x_{max}/(ratio \cdot ni)$
- $ni$ : Number of increments
- $h$ : Distance between increments  $h = x_{max}/ni$
- $ratio$ : Sampling ratio,  $M_{Sample}/M_{Lot}$

For systematic sampling, only  $h$  terms are needed, because the results will repeat themselves in a cyclic manner for indices  $l > h$ . This mathematical sampling is equivalent to circular convolution integration, i.e. the output (the sampled concentrations) is equal to the input (the lot concentrations) convoluted with the sampling function,  $a(x) = f(x) \cdot g(x)$ . Single increment sampling is equivalent to box-car averaging. For stratified random sampling and random sampling, it is slightly more complicated, and this will be treated below.

The position of a sample is indicated by the index for the first element in the sample, so a potential increment could start in all positions  $i = 1$  to  $x_{max}$ . If the increment starts close to the upper limit of the lot, the increment will extend beyond the lot, and in this case the concentrations to be sampled are taken from the start of the lot. This operation is necessary in order for the sampling to obey the fundamental sampling principles, that every fragment in the lot must have the same non-zero probability of ending up in the final sample. This also means that the results are independent of the phase of the concentration profile, see Supplemental material S2 in [14].

For stratified random and random sampling, sums similar to Eq. (1) could be set up but the number of terms would be extremely high for more than a few increments. Instead, a Monte Carlo method is proposed, where the positions of the increments are generated by random numbers. Taking 4000 samples, the results will be accurate to  $\pm 3\%$ .

To estimate SU, all the potential concentrations  $a_i$  from the mathematical sampling for a given sampling method are used in Eq. (3).

The heterogeneity is derived from the heterogeneity of one group.

$$\text{Heterogeneity of one group: } h_i = \left( \frac{a_i - a_L}{a_L} \right) \cdot \frac{M_i}{\bar{M}_i} \quad (2)$$

The Sampling Uncertainty is simply the standard deviation of all potential groups (samples) in the lot:

$$\text{SU: } s_{SU} = \sqrt{\frac{1}{N_i} \sum \left[ \left( \frac{a_i - a_L}{a_L} \right) \cdot \frac{M_i}{\bar{M}_i} \right]^2} \quad (3)$$

In the rest of this paper the weighting of the terms with the masses of the individual groups is neglected. Although it is correct in the spirit of Gy to apply this weighting, it is rarely done in practice, because 1) the mass of the increments are often quite similar, and 2) the increments are rarely actually weighted individually. It would be trivial to include this correction if needed.

Here two things are of the utmost importance:

First: The groups are defined as the groups of potential samples for a specific sampling method. Thus the groups for random systematic sampling, stratified random sampling, random sampling and single increment sampling are different.

Second: The variations in  $a_i$  may not include variations caused by the constitutional heterogeneity, i.e. when the input are theoretical data without effects of fragment properties other than concentrations. In this case SU is equal to GSE alone. When, on the other hand,  $a_i$  are experimental results from sampling experiments, such as data for variographic analysis, SU contains FSE, GSE and all long range errors. In the latter case SU is an estimate of the Minimum Practical Error.

### The Fundamental Sampling Uncertainty FSU [7]

The concentrations within an increment in Fig.1 are not randomly distributed as indicated by the colours in the figure (could be low density fragments at top and high density fragments at the bottom). In this case sampling error due to constitutional heterogeneity (that fragments are different) are not equal to FSE, because FSE is the sampling error when all fragments are randomly distributed within the lot. However, the sampling error due to constitutional heterogeneity can be estimated by the Fundamental Sampling Uncertainty FSU proposed in [7] when the distribution of the fragments is known as function of position. FSU is simply the concentration weighted average of FSE for separate parts of all increments in the sample.

In conclusion: From a table of concentrations of fragments or analyts as function of position the sampling errors due to constitutional, distributional and long range heterogeneities can be estimated by the proposed sampling uncertainties SU and FSU. SU and FSU are proposed as standard uncertainties [8] to distinguish them from the traditional sampling errors.

Workbooks in Excel for estimation of sampling uncertainties SU and FSU are available in Svensmark [14].

## Results and discussion

### Validation of the SU-method: comparison to variographic analysis

SU can be used to predict the sampling uncertainty for 1-dimensional sampling. Examples are given, where the predictions using SU are compared to the prediction obtained from the auxiliary functions obtained by numeric double integration of the 1-dimensional variogram according to Gy [1, 2, 9]. For point selection, i.e. when the mass of the sample is neglectable relative to the mass of the lot the results are correct by the factor  $1/\sqrt{(1-N_i/x_{max})}$ .

In order to produce results similar to variogram integration, the calculations in SU must be somewhat modified. The variogram only considers variations up to half the maximum length of the input, thus the SU cannot be done in all input points at a time, but must be done for half the input points at a time, shifting the range until the whole length has been covered.

Unfortunately an exact comparison is not possible, mainly because of the limitations of variographic analysis. The limitations are 1) the data must be approximately stationary, i.e. the mean and the standard deviation may not change as a function of position, 2) cyclic variations are levelled out, and 3) predictions for systematic sampling are too low for nugget effects around zero [10], and 4) the weighting of the data is not uniform, the centre sample in the variogram contributes twice as much to the results as the first and the last point. There are also limitations for SU in comparison to variograms: When the result should be valid for half the length of the data (as in variograms) it is not possible to use weights identical to the weights in the variograms, see Supplementary material S3 in [14].

For SU this limitation is only present for the comparison to variograms. In normal use, when SU is calculated for a specific length of data, the weights are uniform along the whole length obeying the fundamental sampling principles.

**SU vs variograms for a simple case – influence of trend in data:** This example is with a relatively smooth increasing variogram. The data were taken from Pitard [2] page 119 and the variogram and the predictions from the variogram were identical to the results in [2] within rounding errors. For stratified random and random sampling the predictions from SU are essentially identical to the results of traditional variogram integration Fig. 2. There are tiny differences, but it must be remembered that the method of calculation of the estimates (SU vs variogram+ integration) is completely different.

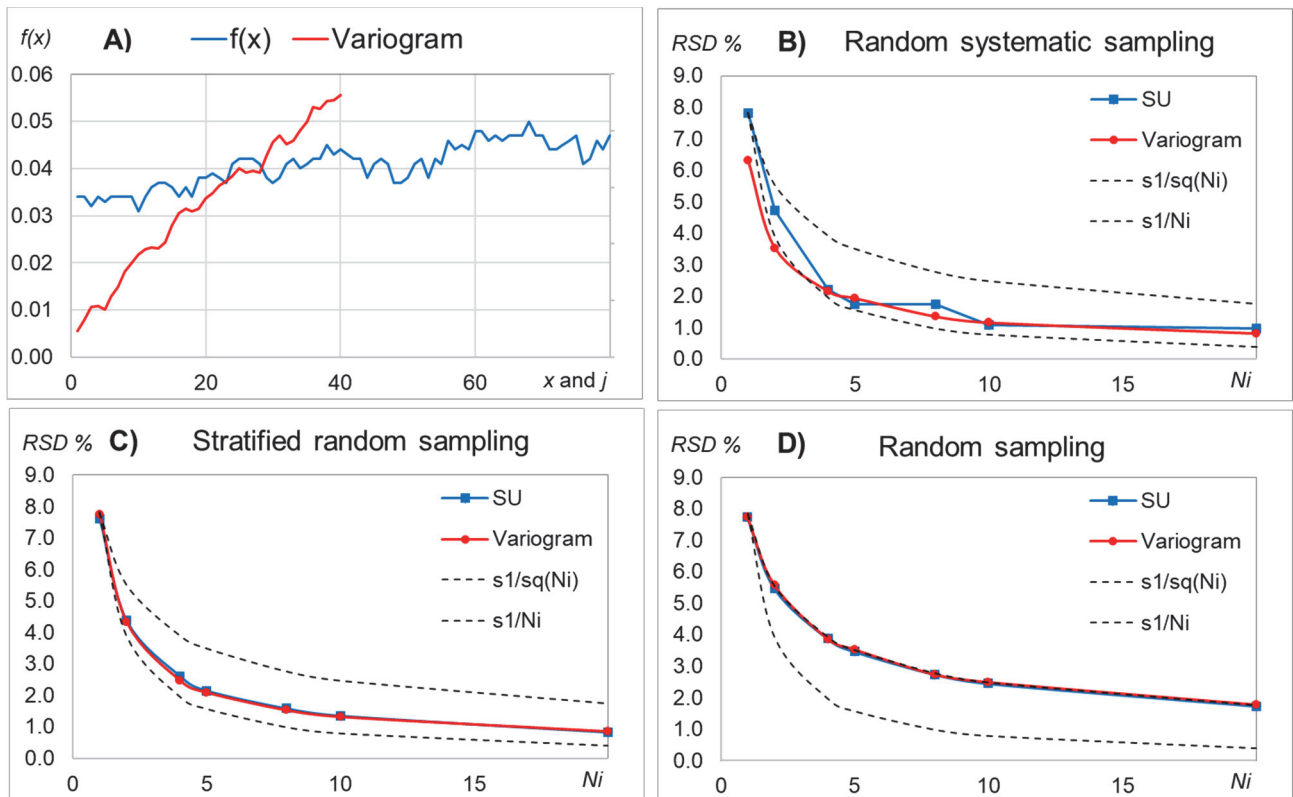

**Figure 2. Influence of trends in data for predictions of sampling uncertainty (RSD %) for variogram integration and for SU estimation. A) Concentrations,  $f(x)$ , and variogram. Data from Pitard [2]. B) to D). Predicted RSD % from SU and variogram integration. The black dotted lines indicate the position for a RSD % proportional to  $1/\sqrt{N_i}$  and  $1/N_i$ .**

Predictions for random systematic sampling show some significant differences: SU has small deviations up and down from a smooth line. The reason for this behaviour is that SU is very sensitive to (even small) cyclic variations, as discussed later. The results from the variogram seem to be too low for small  $N_i$ . The reason for this is that the data are not stationary, as there is an increasing trend in the data.

Also note that the prediction from variograms for the uncertainty for taking a single increment ( $N_i = 1$ ), is different for random systematic sampling ( $RSD \% = 6.3$ ) and stratified random sampling or random sampling ( $RSD \% = 7.7$  and  $7.7$ ). But how can a single increment taken at a random position within the lot have a different uncertainty depending on the sampling method? Random systematic sampling is started at a random position within the first box, and with only one box this would be identical to stratified random or random sampling. To prove that the trend in the data is responsible for this discrepancy, the data has been corrected to remove the trend, i.e.  $\text{slope}(f(x)) = 0$ , see Fig.3.

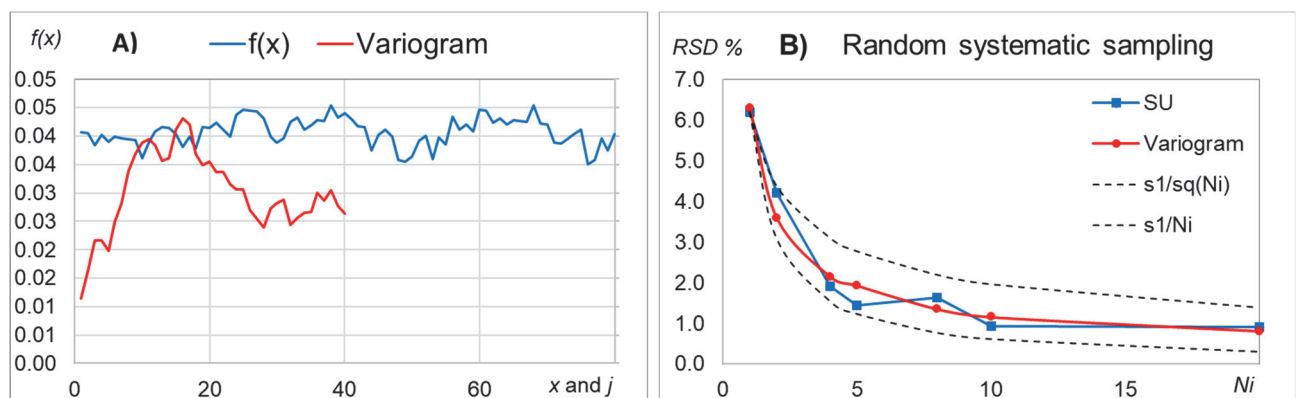
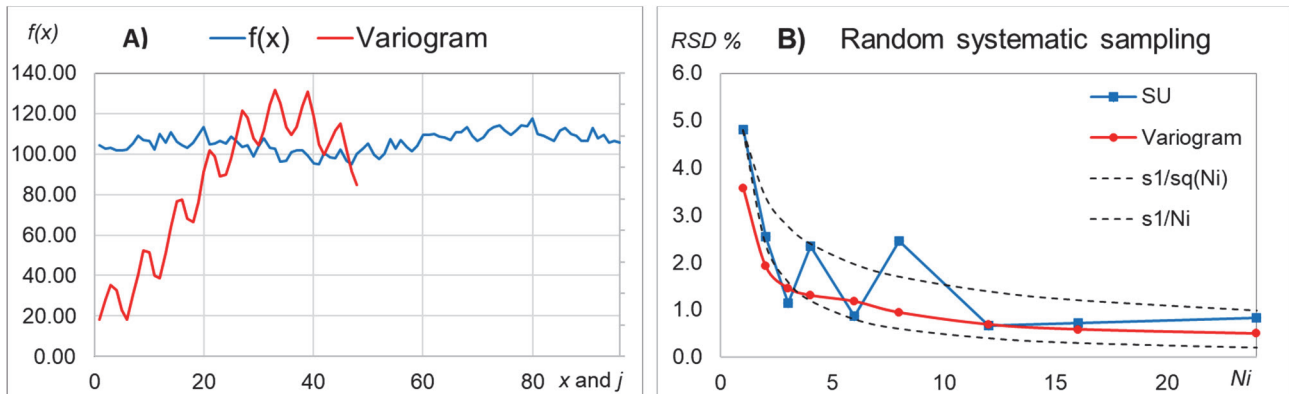

**Figure 3. Data without trends (Slope( $f(x)$ ) = 0). Predictions of sampling uncertainty (RSD %) for variogram integration and for SU estimation.**

Now RSD % for a single increment is the same for all methods and protocols. Note, that RSD % for random systematic sampling from variograms is identical in the two cases (Fig. 2 & 3), i.e. variogram integration neglects linear trends in data. This is easy to understand because for a linear trend the mean integral  $w_j$  will have twice the value of the mean double integral  $w'_{j/2}$ , and the variance for systematic sampling is predicted by  $Var(syst) = 2w'_{j/2} - w_j$  [1, 2, 9], see Supplementary material S4 in [14]. The predictions for stratified random sampling are based on the double integral  $w'_j$  alone, and will thus include the effect of any trend like SU. For random systematic sampling, the predictions from SU are seen to oscillate around the line from variograms because of small cyclic variations.

So both SU and variogram seem to give correct results for stratified random and random sampling in the case of a linear trend, whereas only SU gives reliable predictions for random systematic sampling.

**SU vs variograms for data with cyclic variations:** In this example of length  $x_{max} = 96$ , there is a cyclic variation with a period of  $j = 6$ , as shown by the variogram Fig. 4 A.



**Figure 4. Influence of cyclic variations for predictions of sampling uncertainty (RSD %) for variogram integration and for SU estimation.**

It is seen that there are differences in the predictions for random systematic sampling, even though a common trend is seen. The numeric double integration of the variogram is intended to remove noise, but unfortunately it also levels out cyclic variations. It is well known, from sampling theory for (electric) signals, that sampling with a period equal to that of the signal (or any whole multiple of it), will give a maximum variation of the mean ( $j = 6$  or  $12$  corresponding to  $N = 8$  or  $4$ ), exactly as seen in the SU predictions.

For stratified random sampling and random sampling, the two methods are again essentially identical as expected (data not shown). Supplementary material S5 in [14] shows an example with a pure sine wave variation. So SU will give a correct prediction for all sampling methods even in the case of cyclic variations.

**SU vs variograms low nugget effects and for other cases**

In the first case the nugget effect is zero, and the results from variogram is too low for random systematic sampling, Fig. 5.

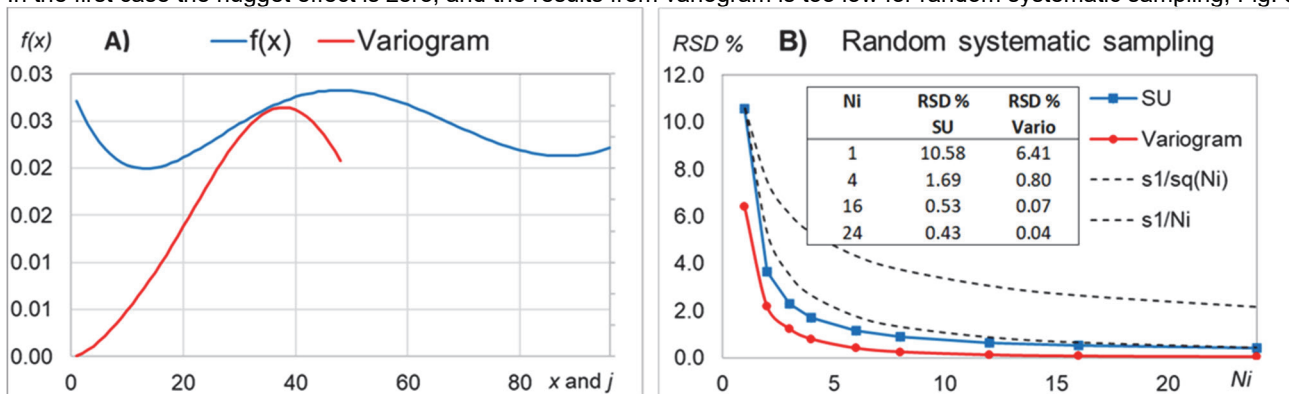

**Figure 5. Influence of a low nugget effect for predictions of sampling uncertainty (RSD %) for variogram integration and for SU estimation.**

For random systematic sampling the difference increases dramatically with decreasing lags, Fig 5 B. So what is the correct sampling uncertainty for  $j = 2$ ,  $Ni = 24$ : 0.04 % or 0.43 %? Heikka and Minnkenen [10] have shown that the variogram integration underestimates the uncertainty for short lags, supporting that variographic integration can give estimates that are too low for random systematic sampling. Actually, the estimation of the nugget effect in variograms may be a problem as shown in [11]. If random noise is added, this difference levels out, see Supplementary materials S6 in [14] where this problem is discussed further.

Examples for data with variation in standard deviation as function of position is given in Supplementary material S7 in [14].

**Summary for SU vs variograms:** The conclusion of the comparison of SU and variograms is that SU gives similar or better results compared to variograms. Also all differences between the SU and variogram results can easily be accounted for by the properties of variogram integration and the different weightings as explained at the beginning of these sections.

In conclusion, SU is a valid method for estimation of sampling uncertainty for 1-dimensional sampling.

#### SU for 1-dimensional data

Contrary to variographic analysis SU can be used to estimate the sampling uncertainty for 1-dimensional data obeying the fundamental sampling principles, i.e. all points will have the same weight (probability) to be sampled. Extensive examples are given in Supplementary materials S8 and S9).

SU can be used to investigate the effect of the sampling method and the number of increments for all cases that can be represented by 1-dimensional data. Even if the effect of these (sampling method and number of increments) are well known in theory, it is only possible to judge the magnitude of the differences from quantitative data: is random systematic sampling better than stratified random sampling, how much is 32 increments better than 8 increments, etc.- that depends very much on the actual case as shown by the examples given.

#### SU for 2-dimensional sampling

Just one example will be discussed, a square Japanese slab cake [12]. The lot is a 120 x 120 grid and samples are taken in 1, 4, 9, 16 and 25 boxes as shown in Fig. 6 I).

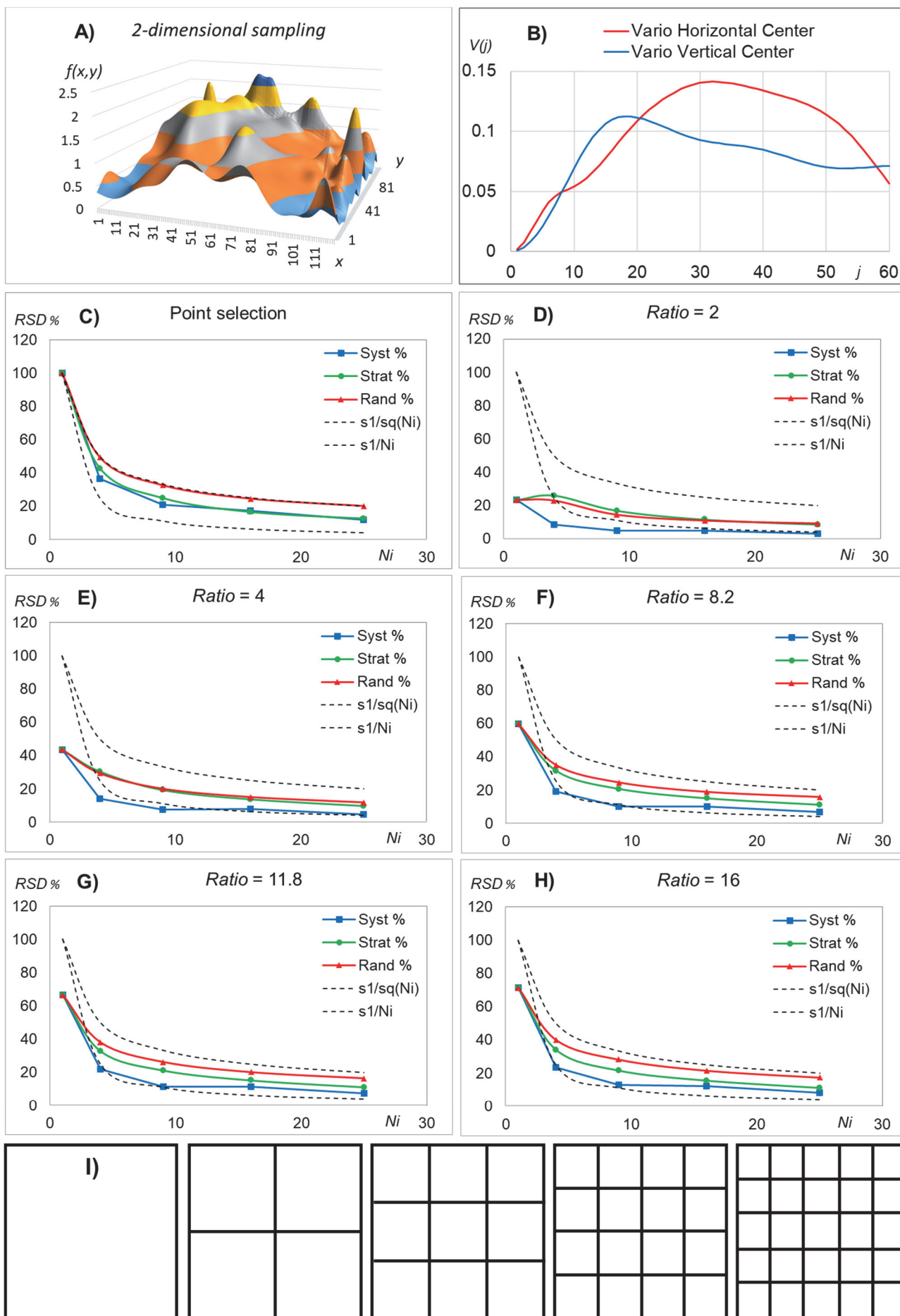

Figure 6. SU for 2-D sampling. A) Concentrations; B) Variogram at the centre in two directions; C) Predicted  $RSD\%$  for 1 to 25 increments for point selection; D) to H) Predicted  $RSD\%$  for sampling ratios from 2 to 16; and I) Sampling strata for 1 to 25 increments. The dotted lines start at 100 % of the standard deviation of the lot, and all  $RSD\%$  are shown in % of standard deviation of the lot.

For these data, with smooth variograms, the random systematic sampling gives the lowest uncertainty, whereas stratified random sampling is similar to random sampling for low sampling ratios (*ratio* = 2 and 4) and intermediate between random systematic and random sampling for higher sampling ratios (*ratio* = 8 – 25 and point selection). The effect of the number of increments increases with the sampling ratio. The effect of the number of increments is small for small sampling ratios, but note that the sampling uncertainty for 1 increment is quite low anyway in this case, only 23 % of the standard deviation of the lot for *ratio* = 2. Note that the results for high sampling ratios approaches that for point selection.

### The Correct Sampling Uncertainty (CSU)

Combination of the fundamental sampling uncertainty (FSU) [7] and the grouping and segregation error gives the correct sampling uncertainty (CSU), i.e. the sampling uncertainty for correct sampling when both the constitutional and distributional heterogeneity of the lot and the sampling geometry (increment size, number and orientation) is taken into account:

$$\text{CSU: } s_{CSU} = \sqrt{s_{FSU}^2 + s_{GSE}^2} \quad (5)$$

**Example of CSU:** For one of the runs in the model experiments for the improved Gy's formula [7] the variation was too high for sand. To estimate how much the distributional heterogeneity must be to explain this, different scenarios were simulated and both FSU and SU (equal to GSE in this case) were calculated, and the resulting CSU was compared to the observed total sampling uncertainty. Samples of ~125 g were taken from 1000 g by using a Riffle splitter with 18 chutes 3 times. The mixture contained 50 g sand, 50 g sesame seeds, 700 g barley grains and 200 g steel balls with a diameter of 6 mm. See ref. [7] for further details. The results of estimating FSU, GSE and CSU are given in Table 1 together with the observed experimental results. Since the concentration of fragments changes as function of the position along the input tray, the effect of the constitutional heterogeneity is slightly different from FSE (calculated as if the whole lot were randomly mixed) and must be estimated by FSU.

**Table 1: Estimated and observed sampling uncertainty RSD %**

	Sand	Sesame	Barley	Steel
FSU	4.0	4.3	3.6	14.1
GSE	8.2	0.0	0.6	0.0
CSU	9.1	4.3	3.6	14.1
OBS	9.1	3.4	3.4	14.1

The distribution of the analytes in the input tray were generated by a random distribution of sand, *mean* = 0.05, *s* = 0.015. The concentration of barley was corrected to give a sum of concentrations equal to one.

The fact that the results fit the experiments nearly exactly does not mean that the distribution is exactly as in the scenario, as many different distributions could all give similar results. What the data and calculations do show is that it is possible to simulate the experiment with a plausible distribution.

This example with a high GSE in a riffle splitter is unusual. Apart from sand in a few experiments in [7] GSE is negligible for proper use of riffle splitters, and good rotary dividers behave similar or even better [13].

**How to minimize the Correct Sampling Uncertainty:** Results in Svensmark [7] show that it will reduce the fundamental sampling error to separate the lot in a direction parallel to the sampling direction, and results given here show that it will reduce the grouping and segregation error by mixing the lot in a direction perpendicular to the sampling direction. It is true, that the spatial distribution of fragments in most cases are unknown, and that they change with manipulation of the lot, but the message is that it is a very bad idea to try to get a uniform distribution in a direction parallel to the sampling increments (normally this would be in the vertical direction), so segregation according to gravity may in most cases be beneficial, even if mixing horizontally is more important.

### Conclusion

The Sampling Uncertainty SU is proposed as a new way of treating correct sampling errors including the grouping and segregation error. SU allows accurate estimation of sampling uncertainty due to distributional heterogeneity and can estimate the effect of the number of increments for the sampling methods random systematic sampling, stratified random sampling, random sampling and single increment sampling. The input for SU is a table of concentrations as a function of position within the lot. For 1-dimensional sampling this is equivalent to the input for variograms, i.e. a series of samples taken in one direction by random systematic sampling. For 2-dimensional sampling the input is a map of concentrations in 2 dimensions. In most cases such experimental concentration maps are not available, but it is often possible to set up realistic theoretical scenarios from prior knowledge or from similar cases.

SU can be used for 1-dimensional sampling and does not suffer from the problems associated with results from variogram integration caused by non-stationarity, cyclic variations and low nugget effects. Real lots do not need to be stationary, and SU will also be correct for non-stationary lots. It is still recommended to calculate the variogram because it gives valuable information about the heterogeneity of the lot, but it is advised to also use SU as a supplement to variogram integration.

SU can also be applied quantitatively to 2-dimensional lots. This is an extension to TOS which only gives quantitative results for 0-D and 1-D sampling. In principles there are no limitations to the number of dimensions that can be used for SU.

SU is very well suited for pedagogical purposes, because all aspects of grouping and segregation and distributional heterogeneity can be simulated with greater accuracy, e.g. to show the benefits of composite sampling by real numbers.

SU allows a quantitative comparison of different sampling schemes and a better-informed selection of the best compromise between precision and 'cost'.

#### Declaration of competing interest

The author declares that he has no known competing financial interests or personal relationships that could have appeared to influence the work reported in this paper.

#### Acknowledgments

Thanks to David Pattison and Giorgio Tomasi for language advices. This research did not receive any specific grant from funding agencies in the public, commercial, or not-for-profit sectors.

#### Auxiliary materials in [14]

Supplementary materials S1-S9

Workbooks for SU and FSU including 1-dimensional and 2-dimensional sampling, variograms and the discrete Fourier transform.

#### ORCID iDs

Bo Svensmark: <https://orcid.org/0000-0003-0430-6181>

#### References

1. P.M. Gy, *Sampling for analytical purposes*, Chichester, England, 1998.
2. Francis F. Pitard, *Pierre Gy's Sampling Theory and Sampling Practice*, 2nd Ed., CRC, 1993.
3. L. Petersen, P. Minkkinen, K.H. Esbensen, *Representative sampling for reliable data analysis: Theory of Sampling*, *Chemometrics and Intelligent Laboratory Systems*, **77**, 261-277 (2005). <https://doi.org/10.1016/j.chemo-lab.2004.09.014>
4. P. Minkkinen, *Dependence of the variance of lot average on the sampling mode and heterogeneity type of the lot*, in S C Dominy and K H Esbensen, *Proceedings of the 8th World Conference on Sampling and Blending*, 8 – 11 May, 2017, Perth, Australia, The Australian Institute of Mining Metallurgy Publication Series 2/2017, pp. 319-330. ISBN 978 925100 56 3.
5. P.O. Minkkinen and K.H. Esbensen, *Sampling of particulate materials with significant spatial heterogeneity - Theoretical modification of grouping and segregation factors involved with correct sampling errors: Fundamental Sampling Error and Grouping and Segregation Error*, *Analytica Chimica Acta*, **1049**, 47 – 64 (2019). <https://doi.org/10.1016/j.aca.2018.10.056>
6. B. Geelhoed, M.J.J. Koster-Ammerlaan, G.J.C. Kraaijeveld, P. Bode, D. Dihalun and H. Cheng, *An experimental comparison of Gy's sampling model with a more general model for particulate material sampling*. Fourth World Conference on Sampling & Blending, The Southern African Institute of Mining and Metallurgy, 2009.
7. B. Svensmark, *Extensions to the Theory of Sampling 1. The extended Gy's formula, the segregation paradox and the fundamental sampling uncertainty (FSU)*, *Analytica Chimica Acta* **1187**, 339127 (2021). <https://doi.org/10.1016/j.aca.2021.339127>
8. *Guide To The Expression Of Uncertainty In Measurement*. ISO, Geneva (1993). (ISBN 92-67-10188-9) (Reprinted 1995: Reissued as ISO Guide 98-3 (2008), also available from <http://www.bipm.org> as JCGM 100:2008)
9. L. Petersen, K.H. Esbensen, *Representative process sampling for reliable data analysis - a tutorial*, *Journal of Chemometrics*, **19**, 625-647 (2006). <https://doi.org/10.1002/cem.968>
10. R. Heikka ) and P. Minkkinen, *Integration of the variogram using spline functions for sampling error estimation*, *Chemometrics and Intelligent Laboratory Systems* **44**, 205–211 (1998). [https://doi.org/10.1016/S0169-7439\(98\)00187-7](https://doi.org/10.1016/S0169-7439(98)00187-7)
11. R. Heikka and P. Minkkinen, *Comparison of some methods to estimate the limiting value of the variogram,  $vh(j)$ , for the sampling interval  $j=0$  in sampling error estimation*, *Analytica Chimica Acta* **346**, 277-283 (1997). [https://doi.org/10.1016/S0003-2670\(97\)90063-5](https://doi.org/10.1016/S0003-2670(97)90063-5)
12. P. Gy, *Sampling of heterogeneous and dynamic material systems*, *Data Handling in Science and Technology – volume 10*, Chapter 22, Elsevier 1992
13. L. Petersen, C.K. Dahl, K.H. Esbensen, *Representative mass reduction in sampling - a critical survey of techniques and hardware*, *Chemometr. Intell. Lab. Syst.*, **74**, 95-114 (2004). <https://doi.org/10.1016/j.aca.2021.339127>
14. B. Svensmark, *Toolbox for analytical chemistry*, [www.bosvensmark.dk](http://www.bosvensmark.dk)





## Process optimization by real time analysis of liquids' composition in Metal & Mining

F. Maggiore<sup>a</sup>, E. Thisted<sup>b</sup>, A. Mouris<sup>a</sup> and T. Eivindson<sup>c</sup>

<sup>a</sup>Hobré Instruments B.V., Netwerk4, 1446WK Purmerend, Netherlands. E-mail: [f.maggiore@hobre.com](mailto:f.maggiore@hobre.com); [a.mouris@hobre.com](mailto:a.mouris@hobre.com)

<sup>b</sup>Glencore Nikkelverk AS, Pb 604, 4606 Kristiansand, Norway. E-mail: [Elke.Thisted@glencore.no](mailto:Elke.Thisted@glencore.no)

<sup>c</sup>Torkild Eivindson Consulting AS, Tvidøblane 56, 4700 Vennesla, Norway. E-mail: [torkildeivindson@gmail.com](mailto:torkildeivindson@gmail.com)

The XRF method, with a long-proven track record, is one of the most common analytical techniques for elemental measurement in the metal & mining industry. The technology offers high safety, low OPEX, with high versatility and availability, covering the whole range of concentrations, starting from ppb levels (in the range of 0,00001%) up to 100%. The success of the technology lies in the fact that it can be applied to most of the periodic table, can be used on both solids and liquids, gives real time measurements on the spot, is non-destructive for the sample and does not consume chemicals. In addition, the technique often does not require high skills to be applied, provided that the methods for the XRF-analysis are set up correctly by means of a suitable calibration. Among these benefits, one of the main reasons to elect this technique over others available, is the “speed of response” that can give a feedback within seconds of what is taking place in a hydrometallurgical process, indicating for instance a reaction occurring or not occurring, a side reaction rate increase, reagents being depleted or the formation of unwanted species leading to an emergency situation. Process Engineers and operators often require knowing step after step what is going on inside a reactor, in order to be able to intervene as early as possible. Today, thanks to a multi-element analysis by XRF, fortunately this is possible.

Alike any test technique, sample preparation is crucial, thus measuring on representative samples is key to control process optimization and obtain real-time feedback on metals and other elements, in order to improve quality, planning, safety, to prevent unknown losses and reduce use of excess chemicals. This brings about not just an economic benefit, but also an overall improved environmental balance. Also, small improvements at every step of an integrated hydrometallurgical process, at the end may result in large quantities of revenues for increased throughput, improved product quality, reduced reagents, but it will also reflect into a better use of resources, reduction of raw materials used, decrease of emissions and waste to be disposed of. For instance, a more efficient water treatment process will save more metals, while releasing a waste solution with a lower impact to the environment.

When an ore is concentrated into a metal containing matte, it must undergo a leaching stage that will dissolve some elements and leave others in the solid form. Having a thorough control of all the elements present is not trivial, but it is key to optimize all the following refining stages, since ores are never constant in composition and from time-to-time unwanted elements may exceed the limit without notice. This is a perfect case in which the “speed of response” and the “high accuracy” of an online analysis can play an important role for the Metal & Mining processing industry. In this paper, the authors introduce their own “case study”, made by the world renown and leading manufacturer Glencore, at its Nikkelverk plant in Norway, that has made use of the “C-Quand online XRF analyzer” fabricated by Hobré Instruments, a world leading manufacturer of analyzers and sample conditioning systems. The online XRF analyzer is employed for the control of the critical leaching phase of the Ni-Co-Cu matte, substituting a much more complicated and costly analytical technique that used to make use of a lot of reagents and a large equipment. In addition, the technique used before required a substantial amount of human workforce to cope with maintenance of the systems. The results, challenges and the improvements of the first two years of utilization of the online XRF analyzer will be shared, showing that Process Control cannot live without proper measurement, thus measurement on representative samples is truly the heart of processes.

### Introduction

Every human activity requires resources, thus it is particularly important to optimize their use, as their depletion is a vital global concern that affects the life of every individual, especially when they are not renewables. Beside scarcity, society faces acquisition difficulties as mining is not evenly spread out all over the world. For instance, the “Earth Overshoot Day” is just an example of one of the many parameters and indicators showing how we are going in the wrong direction by depleting the “projected allocated resources” of a given year, in a shorter and shorter time, year after year. In metal processing field, every step poses important optimization opportunities for its environmental and economic impact.

The practical approach of resource management is particularly well suited to the metal & mining industry, which have much scope to adopt a sustainable approach to their activities. Besides considering the environmental and collective impact of their operations, metal & mining companies ought to take steps to minimize negative effects<sup>1</sup>, share best practice (often referred as best available techniques<sup>2</sup>), reuse resources used during processing, minimize the environmental impact and reduce waste.

### Optimising mining performance and Minimising “wasted” resources

Mining as an industry creates much waste, including depleted rock, gaseous emissions, sludges, mine water and spent water from hydrometallurgical processing. Some of these streams can be reused, either within the same production or re-purposed elsewhere.

For instance, waste rock can be used as backfill as landscaping material or in road construction, while the sludge can be used in pigments. Other by-products can be re-used for making construction materials (e.g. bricks or in cement kilns), resins, glass and glazes, in agroforestry, or as part of the wastewater treatment process<sup>3</sup>.

There are also other waste streams related to the subsequent stages of smelting, up to the final refining steps of the minerals. Considering the concept of the “waste hierarchy”, the first step to take to minimize resource use is “reducing the amount” used. One way to do this is to optimize the leaching and extraction processes, in order to “leave behind” as little as possible of the key metals contained in the ore to be processed. For instance, if in an ore containing 2,0% cobalt the froth flotation process would leave behind a content of 0,1%-0,5%, it would mean that 1-5 kg of Cobalt per metric tonne of ore would end up in the waste stream. This would likely cause a “contamination” problem to the secondary uses mentioned above, but in terms of resources, it means that 5-25% of the contained cobalt does not get extracted. To understand the impact, it can be considered that in order to produce 1 metric tonne of cobalt, in this example 53-67 t of ore would be required. Comparing this to the 50 t required if the process was 100% efficient, it is clear that 3-17 extra metric tonnes need to be processed, with all the impact related. Multiplying this amount by 10 kt of cobalt produced per year by a large producer, would mean 30-170 kt of extra ore that ends up in the waste stream, containing an equivalent of 30-850 t of Cobalt!

In order to optimize every step of the process, it is important to closely monitor the chemistry of the reactions occurring and this can only take place effectively through a continuous process sampling and control. The continuous analysis, active 24 hours a day, minimizes the dependence on operator's intervention, as the process disturbances are rarely predictable.

### Continuous process analyzers for hydrometallurgy

The online analysers traditionally used to control hydrometallurgy in real time include techniques like photometric analysis. In recent years new analytical equipment like titrators and voltametric analysis have been implemented to improve the process control. Every technique has been developed to solve some problems, but some of them bring real challenges for their deployment. For instance, the photometric analyses require several stages to measure different elements since each photometer only measures one element at the time and a large room for the equipment. At Nikkelverk, the photometric analytic method for Ni, Co and Cu reported in g/L is simple, measuring the colour of the solution and relating it to the concentration via Lambert-Beer's law without adding any chemicals. The main problem is the need of dilution of the process solution prior to analysis. The dilution is not accurate and can therefore give poor results. For trace analysis of these elements, chemicals need to be added to enhance the samples response when measured.

In general, titrators may require a long time before the titration is complete and if the reaction is contaminated by other species, results can be altered. Inductively Coupled Plasma (ICP) is probably the most widely used technique in benchtop laboratory equipment, however the difficulty to apply it for a continuous process control lies mostly in the sample preparation that needs to be appropriately diluted based on the actual concentration. Finally, the XRF technique, which is the main technique discussed in this paper, in short requires a compact analyzer, no need of reagents, does not consume or alter samples, does not need dilution and can work on a very extended range, from sub ppm to 100 wt%. The specific details are discussed in the next section.

### XRF technique

X-ray fluorescence (XRF)<sup>4</sup> is an analytical technique that can be used to determine the chemical composition of a wide variety of sample types including solids, liquids, slurries and loose powders. It is also used to determine the thickness and composition of layers and coatings.

XRF spectrometry is a non-destructive analytical technique used to obtain elemental information from different types of materials, as it can analyse elements from beryllium (Be) to uranium (U) in concentration ranging from sub-ppm levels to 100 wt%. It is employed in many industries and applications including: cement production, glass production, mining, iron, steel and non-ferrous metals, oil & gas, polymers and related industries, forensics, pharmaceuticals, healthcare products, environmental, food and cosmetics.

XRF analysis is a robust technique, combining high precision and accuracy with straightforward, fast sample preparation. It can be readily automated for use in high-throughput industrial environments, while providing both qualitative and quantitative information on a sample. The technique is so versatile that it is often used for rapid screening (semi-quantitative) analysis too.

XRF is an atomic emission method, similar in this respect to optical emission spectroscopy (OES), ICP and neutron activation analysis (gamma spectroscopy). Such methods measure the wavelength and intensity of 'light' (X-rays in this case) emitted by energized atoms in the sample. XRF makes use of X-ray radiation to eject an electron of the measured element from the inner orbit; the vacant place will be taken by a higher orbit electron, under emission of a very specific wavelength of X-ray radiation: fluoresce (Figure 1). The amount of energy coming from the sample in this wavelength has a linear correlation with the concentration for a short concentration range. The enhancement and absorption effects make the

calibration itself more complicated, however this can be corrected by mathematical models in the instrument software.

An X-ray tube produced irradiation by a primary X-ray beam, causing emission of fluorescent X-rays with discrete energies characteristic of the elements present in the sample (Figure 2).

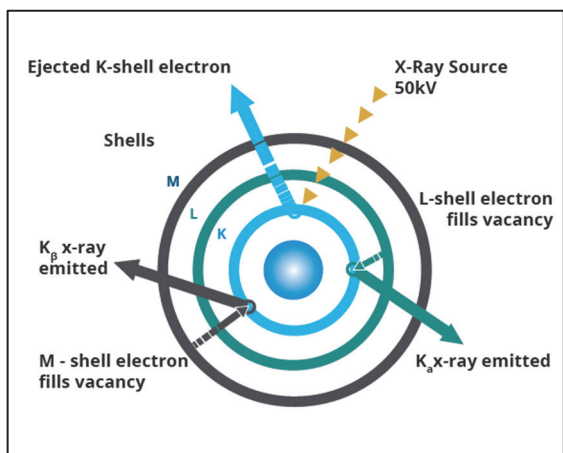

Figure 1. X-Ray fluorescence principle.

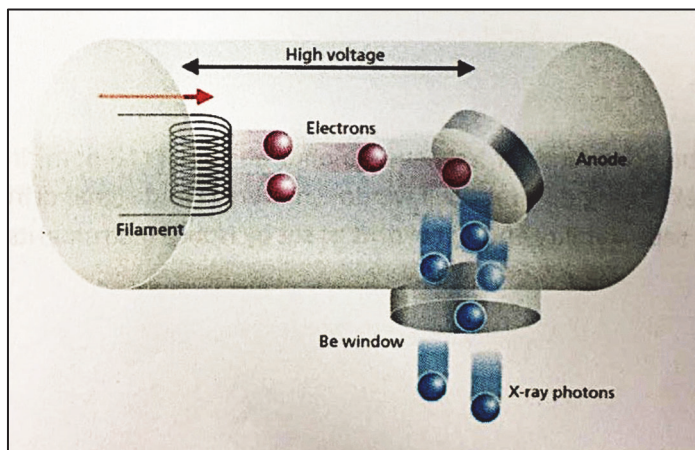

Figure 2. X-Ray basics.

A radiation source stands at the basis of all spectrometers, together with a sample and a detection system. The technology used for the separation (dispersion), identification and intensity measurement of a sample's X-ray fluorescence spectrum gives rise to two main types of spectrometers wavelength dispersive (WDXRF) and energy dispersive (EDXRF) systems. For the purpose of this paper, the latter will be considered.

In EDXRF spectrometers, the X-ray tube acts as a source, it irradiates a sample directly and the fluorescence coming from the sample is measured with an energy dispersive detector. This detector is able to measure the different energies of the characteristic radiation coming directly from the sample. The detector causes a separation (called dispersion) of the radiation from the sample into the radiation from the different elements present in the sample. Thus on the detector X-rays are converted to electron clouds, proportional to the energy of the X-ray. The clouds "drift" down a field gradient to the anode, and get collected to charge a capacitor (figure 3).

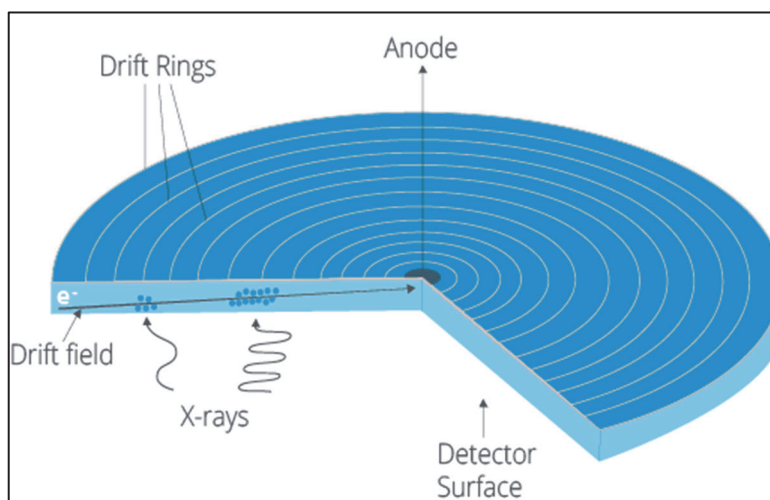

Figure 3. Energy dispersive detector<sup>5</sup>.

### Glencore Nikkelverk process

Glencore Nikkelverk is the biggest nickel refinery in the western world exporting 100% of the production, primarily containing nickel, copper and cobalt. Around 50 product variances are exported to markets all over the world from the Nikkelverk. A characteristic of all the products is high quality and the purity of the finished metals are amongst the highest in the world.

Since 1910 Nikkelverk has refined, produced and exported nickel and other metals from the production plants in Kristiansand. Product development has been necessary to satisfy the needs of the customers. Its environmental, energy and process technology has made the Nikkelverk plant one of the most effective and technologically advanced refineries in the world. The Nikkelverk process begins by crushing the raw material into a fine powder and transporting it to the chlorine leach plant. Here the metals in the raw material are separated by addition of chlorine in hydrochloric acid. The separated streams are then sent to different processing areas for purification and refining. Various process areas treat gaseous, liquid and solid materials (see figure 4). From these areas, the different products are sent for finishing treatment, cutting, and packaging before they are shipped out to the world market.

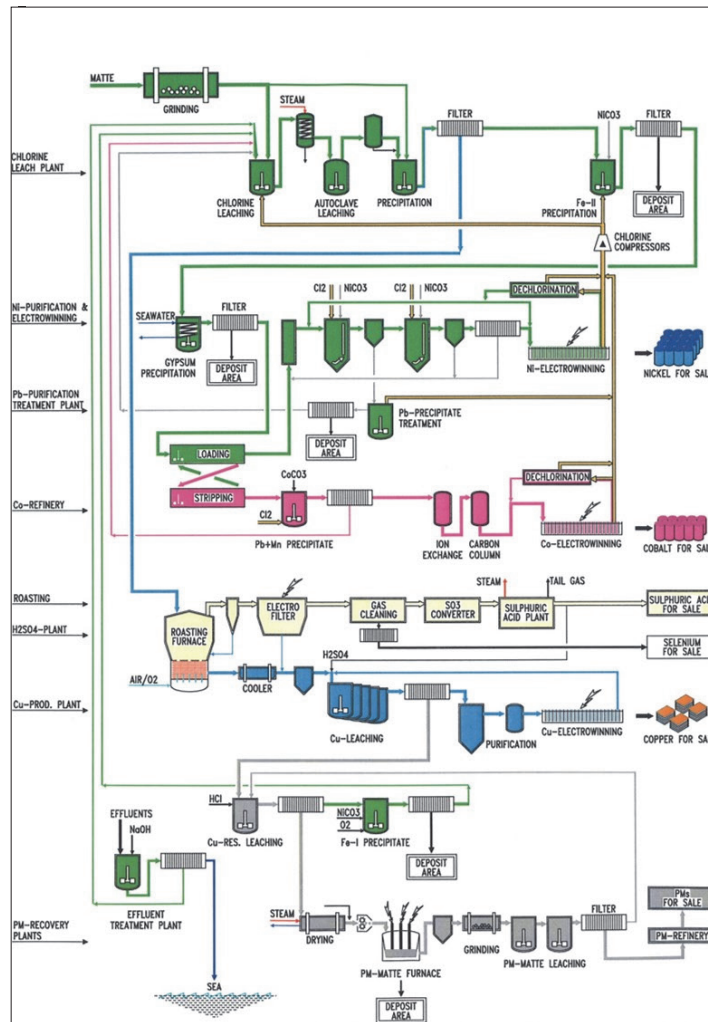

Figure 4. Flowsheet of Nikkelverk's process.

### XRF analysis applied to leaching

The first step for treating the extracted ore is generally a froth flotation process that concentrates the metals contained. Afterwards, the concentrate is transformed in a sulphide matte. This matte is then transferred to the hydrometallurgical section, whose first step is leaching, which is the process of dissolving a solid into a suitable solution, in order to allow the following steps entailing purification, precipitation and so on, until final refining.

In order to optimize the leaching process, it is required to run a real time analysis to the process, especially because the matte coming from an ore can be fairly variable in composition. This continuous analysis can be run through XRF technology, as this is the most viable technique available, given its versatility and speed of response. For this reason, after many years of successful use of photometric techniques, *Glencore's Nikkelverk* plant in Norway has decided to switch to XRF for the control of the critical leaching phase of the Ni-Co-Cu matte. The selected analyzer for this purpose is a "C-Quand" fabricated by *Hobré Instruments*, a world leading manufacturer of analyzers and sample conditioning systems. The main advantages of this analyzer are:

- Multi elements simultaneous analysis
- Ability to handle the whole pH range
- Analyse a wide range of concentration without consuming the sample
- No dilution of sample
- No need of reagents
- High precision measurement
- High stability measurement
- It can be used with both aqueous or organic solutions

### Calibration of the instrument

Before being able to run a sample into an analyzer, it is important to calibrate the instrument for the given elements and range to check. XRF technology makes no exception in this regard. Thus, the calibration takes into account as many variables as possible, but most importantly:

- Primary elements required for the process
- Secondary elements (less important) for the reaction
- Contaminants (e.g. elements that affect X-Ray absorption)
- Matrix (e.g. aqueous solution, organic solution)
- Solid particles possibly present

In general, all elements influencing the calibration need to be a part of the calibration setup. The calibration allows the build-up of a “calibration curve”, that is a general method for determining the concentration of a substance in an unknown sample by comparing the unknown to a set of standard samples of known [concentration](#)<sup>6</sup>. Thus, the known samples must be representative and take into account the concentration ranges for the items enlisted above and assess the correlation of as many variables as possible. The ideal situation entails a linear relationship where the curve can be approximated to a straight line, however often this is not the case, such that calibration could need to be split for the different applicable ranges and limits could be introduced to curb the possible combinations.

Prior to calibration, it is important to be aware of matrix effects and possible overlap corrections for each element as well as pile-up signals from the detector which can distort the real analytical content of the elements to be analysed. In this specific case study, the calibration of the Online XRF at Nikkelverk was done with “inhouse” calibration samples which are mainly process samples from different part of the plant. Actual process samples are not suitable as calibration samples, since they are unstable and start to precipitate when cooled to room temperature. Therefore, the “inhouse” calibration samples are more diluted than the actual process samples to be analysed. Furthermore, synthetic calibration samples from pure chemicals, called primary standards, were also implemented into the calibration to cover the whole concentration range.

The major elements in all calibration samples were determined on a WD-XRF-instrument (Axios) at the main lab. The minors and trace elements were determined with ICP and AAS. The calibration is made by using theoretical alphas corrections for all fourteen elements in the calibration. Water is used as a “balance-element” in the calibration model. This calibration model gave the best calibration for a wide concentration range and was found to be suitable for all the actual process solutions.

### Test run

Once the calibration has been set, unknown samples can be analysed making use of the calibration curves, to analyse the elemental composition.

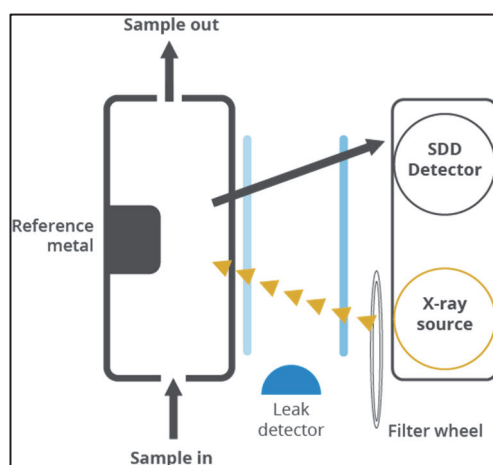

**Figure 5. Hóbré C-Quand XRF analyzer cell layout.**

Figure 5 shows the Hóbré C-Quand XRF analyzer cell, indicating that there is a continuous flow through the cell, subject to a continuous X-Ray irradiation used to measure the sample continuously. The analyzer then displays a “moving average” over a definite timeframe, so that each result is high in accuracy and repeatability.

During test run, the XRF-system needed to be adjusted to fit the needs of the Nikkelverk’s process solution. For example, the flow cell, where the process solution is exposed to X-rays, was redesigned to make it deeper fulfilling the concept of an “infinite thick sample”. Furthermore, the Hóbré’s Online XRF instruments uses normally a reference metal (for instance Zirconium) as a part in the flow cell to be able to correct for drift in the instruments. This reference metal had to be removed for Nikkelverk’s purposes since its signal during measurement of the calibration samples interfered with the calibration model. Drift correction has therefore been done with a Zirconium containing solution added manually to the system.

After adjustment of the Online XRF system and successful calibration, another issue to be solved was the injection of the samples to the instrument. The used layout installation analyses three process streams sequentially. Therefore, a sample extraction system for each process stream is needed ensuring that the “actual” process composition is introduced into the analyser at all time giving real-time results. The amount of particles in these solutions was initially assumed to be minor, but after a few months of tests it was revealed to be more substantial. The number of particles can vary in relation to events in process steps prior to the analyser. With the valves initially installed in the sampling system, clogging was occurring frequently and it disrupted the continuous measurements. These valves were exchanged with so-called “slurry valves”, able to cope with particles in the process solution, thus the clogging problem was solved and it was ensured a more stable operation of the complete analytical system.

Since the process solutions contain at times chemical components which can deposit over time on equipment part like tubes, valves or in the flow cell, a frequent washing cycle of the sampling and XRF-system is necessary. This has to be done manually by the operator for the current time-being and is planned to be automated in the future.

Processing of data

Currently, both the photometric analyses as well as the Online XRF analyser are running parallel at the plant. This gives the opportunity to compare the two different systems with each other.

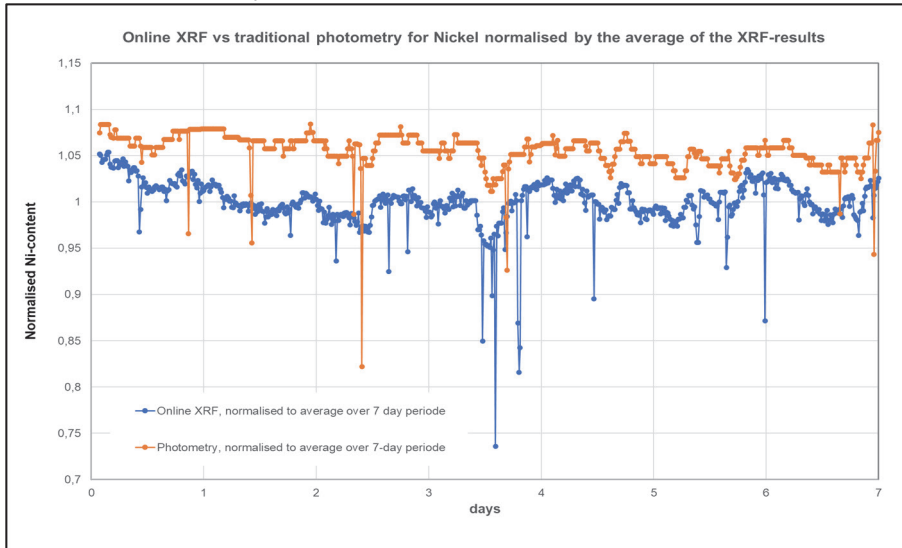

Figure 6: Plot of Ni results, normalised towards 7-day average of XRF-analysis, for both XRF and photometry.

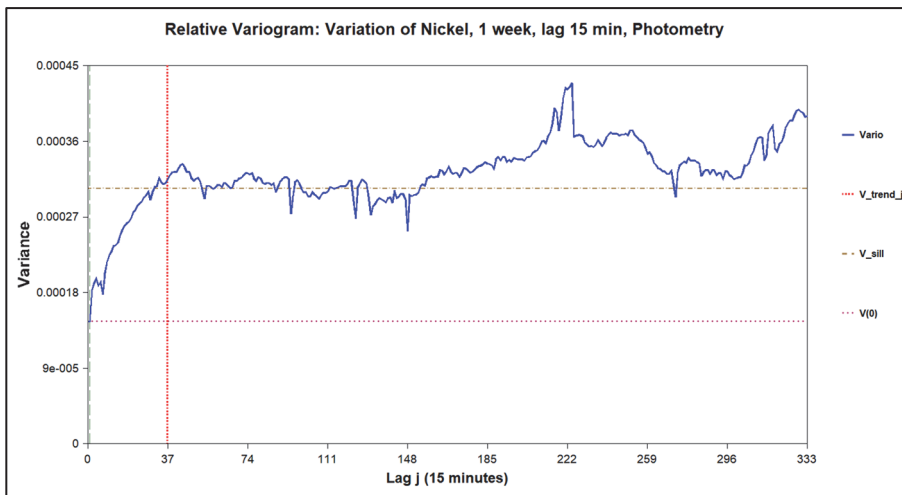

Figure 7: Relative variogram of Nickel measured by the Online XRF

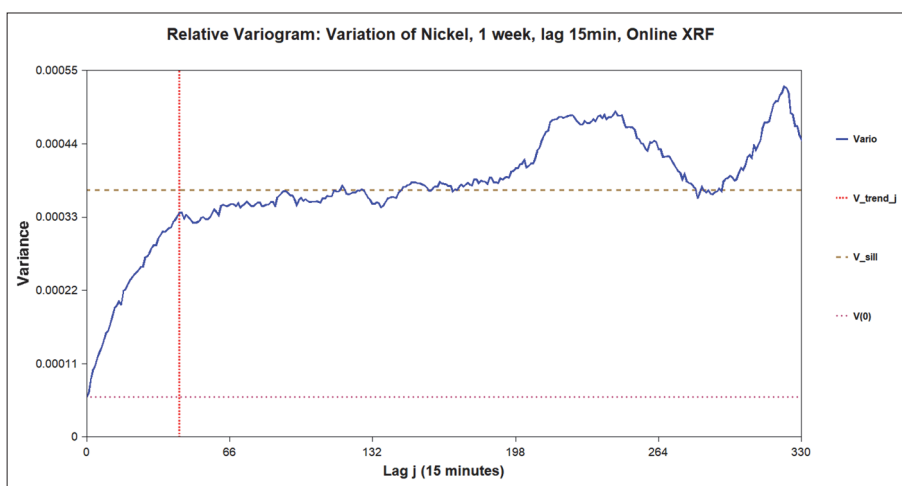

Figure 8: Relative variogram of Nickel measured by photometry

Figure 6 clearly shows a bias between the traditional analysis, photometry, and the newly established XRF-method. However, the trends of the two separate curves are similar. The XRF-system transfers its data to the steering system via Modbus. The photometric measurements are transferred via an analog system and filtered, as can be seen from the graph, with a certain threshold. The drops in concentration during the 7-day period are due to loss of sample towards the instruments, and for the XRF-system the washing cycles with acidic solution.

To determine the variance of the analytical systems, though limited for the photometry due to filtration, one can apply a variographic analysis for both series as shown in figures 7 and 8.

**Table 1: Comparing the relative variance of the measurement systems to the relative total variance of the process**

Extracted key variables	Online XRF Nickel	Photometry Nickel
$V_{(0)}$ – measurement system variation	0,00006	0,00013
$V_{(sill)}$ – total variation	0,00037	0,00030
Ratio in % for $V_{(0)}/V_{(sill)}$	16	44

Variance table

As presented in table 1, the measurement system variation presented as  $V_{(0)}$  is rather small compared to the total variance of the process regarding the Online XRF analyser. The photometric method shows a higher measurement system variation compared to the overall total variance though it would be expected to have a rather low  $V_{(0)}$  due to the similar values at times in figure 6 for the photometric measurements. Nevertheless, if the reason for this discrepancy is due to presentation of  $V_{(0)}$  or the filtration of the photometric data by the setup in the data transfer system, the relative total variance is in the same order of magnitude. The improved data transfer by Modbus for the Online XRF analyser will give a better insight for the process operators.

Looking at the ratio between measurement system variation and total variation, reported to be 16% for the presented 7-day period, this is in accordance with the demand that measurement systems under control should contribute close to or below 10% to the total variance<sup>7, 8</sup>. Since the Online XRF system still is above 10%, this can be explained with the lack of an automated acid rinsing procedure and that the calibration can be further refined.

### Reliability of measurements

As for many analytical systems incorporated on-, in- or at-line, the system itself has a high precision when tested in controlled conditions. However, presentation to process solutions changing over time as well as how the samples are introduced to the analytical system is a major challenge. The reliability of the measurements is primarily influenced by the feasibility of collecting representative samples, and by the sample matrix (liquid totally or partially free from particles). In this specific example, as samples normally contain some solids, it has been necessary to design a sample conditioning system including slurry valves that can cope with the solid particles present. In addition, in order to keep the lines free from obstructions, they have been subject to a washing from the sample take off point to the analyzer inlet, every 8 hours, using a warm acid solution. This routine has increased the uptime to over 95%. Future improvements will entail an automatic acid rinse routine.

### Advantages of continuous measurement in Nikkelverk's hydrometallurgical process

Since the 1970s, Nikkelverk has applied online analytical systems in the hydrometallurgical process to improve the ability to control the processes in real-time. At that time, it was not possible to purchase online analytical equipment easily from suppliers. Therefore, the systems still running at Nikkelverk were setup by very skilled inhouse resources enabling Nikkelverk to run its processes in a much more precise manner and counteract fast upcoming situations. However, the systems installed at that time require constant maintenance and consume partly vast amount of chemicals. As mentioned in the previous section, one system analyses one element at a time which results in a massive instrument park to be maintained today.

Therefore, current commercially available systems like the Online XRF have been implemented at Nikkelverk, reducing the use of resources. As for the implementation of the Hobr  Online XRF analyzer, the use of chemicals for analytical purposes is redundant, leading to a safer work environment for the operators. The maintenance work is reduced from currently nine photometric to one XRF instrument, reporting simultaneously results for 14 elements for each of the three process streams. As the XRF instrument is running stable with the present washing routines, the results reported are extremely helpful for the operation of the process. Since components like sulphate can now be reported in real-time to the shift operators, balancing of the process has become more stable, improving quality, saving resources and improving the overall safety.

### Conclusions

In this paper they were discussed the advantages of the XRF technique for the continuous monitoring of hydrometallurgical processes. A special focus has been given to the leaching stage of Glencore's Nikkelverk plant, for which it has been employed Hobr  Instruments' C-Quand XRF analyzer, customized according to the plant's special needs and requirements.

To get the Online XRF analyzer to its optimum, further improvements are planned regarding the automated washing procedure and an even more fine-tuned calibration. The outcome of the first 2 years of operation has shown that application of modern analytical equipment enabling multielement analysis is the ideal tool to reach improved process control and reduce use of resources, while providing a safer, more reliable and "requiring less maintenance" instrument to the operators. Though the development of XRF-methods and the need to customize the sampling system to fit-for-purpose tool was time-consuming, it is less time consuming than running and maintaining the old analytical techniques employed. Thus, Glencore Nikkelverk's result so far show clear benefits for the long run.

### ORCID iDs

A. Fabio Maggiore: <https://orcid.org/0000-1111-2222-3333>

B. Elke Thisted: <https://orcid.org/0000-0001-5798-5144>



## References

1. Industrial Emissions Directive 2010/75/EU (Integrated Pollution Prevention and Control) <https://eippcb.jrc.ec.europa.eu/reference/>.
2. Best Available Techniques (BAT) Reference Document for the Non-Ferrous Metals Industries [https://eippcb.jrc.ec.europa.eu/sites/default/files/2020-01/JRC107041\\_NFM\\_bref2017.pdf](https://eippcb.jrc.ec.europa.eu/sites/default/files/2020-01/JRC107041_NFM_bref2017.pdf)
3. International Council of Mining and Metals <https://miningwithprinciples.com/>
4. <https://www.malvernpanalytical.com/en/products/technology/xray-analysis/x-ray-fluorescence>
5. P. Lechner et al., "Silicon drift detectors for high resolution room temperature X-ray spectroscopy", *Nuclear Instruments and Methods in Physics Research Section A: Accelerators, Spectrometers, Detectors and Associated Equipment* **377**, issues 2-3, 346-351(1996). [https://doi.org/10.1016/0168-9002\(96\)00210-0](https://doi.org/10.1016/0168-9002(96)00210-0)
6. "Worksheet for analytical calibration curve" <https://terpconnect.umd.edu/~toh/models/CalibrationCurve.html>
7. K.H. Esbensen and P. Paasch Mortensen, "Process Sampling (Theory of Sampling, TOS) – the Missing Link in Process Analytical Technology (PAT)", in *K Bakeev (ed.)*, 37-80. Oxford, Wiley-Blackwell (2010).
8. K.H. Esbensen and C. Wagner, "Theory of sampling versus measurement uncertainty (MU) – a call for integration. Trends in Analytical Chemistry", **57**, 93-106 (2014). <https://doi.org/10.1016/j.trac.2014.02.007>

## Monitoring the lot mean and uncertainty estimates by piecewise local modelling

P. Minkkinen<sup>a,b</sup>

<sup>a</sup>Lappeenranta Lahti University of Technology (LUT), PO Box 20, FI-53851, Lappeenranta, Finland, email:

Pentti.Minkkinen@lut.fi

<sup>b</sup>Sirpeka Oy, Lampisuonkatu 9, FI-53850, Lappeenranta, Finland, email: pentti.minkkinen@sirpeka.fi

Variography is an excellent tool for monitoring the long-range trend of continuous processes. Pierre Gy has presented a method that can be used for estimating the measurement variance of a lot mean as function of sampling frequency for different sampling modes: random, stratified, and systematic sample selections. The method involves the estimation of the intercept (also called the nugget effect) of the variogram at the time point zero, and numerical integration of the variogram. The method can also be used for optimising sampling plans. At the time when variography was developed on-line analysers were not available. Samples were extracted from the process streams and analysed in laboratories. It was important to optimise the sampling plans to control the analytical costs and the reliability of the plans in estimating the estimation error. For a reliable variogram more than thirty to forty samples had to be analysed. Consequently, the results could not be used on-line.

Currently process analysers are widely used to monitor continuous processes. Like in variographic estimation of the lot mean this method is based on the theory of stratified sampling. If the lot is divided into  $N_1$  strata of equal sizes (or sublots) of which  $n_1$  are sampled the variance of the lot mean  $a_L$  is

$$s_{a_L}^2 = \frac{N_1 - n_1}{N_1 - 1} \cdot \frac{s_1^2}{n_1} + \frac{N_2 - n_2}{N_2 - 1} \cdot \frac{s_2^2}{n_1 \cdot n_2} \approx \frac{s_2^2}{n_1 \cdot n_2}, \text{ if } N_1 = n_1 \text{ and } N_2 \gg n_2$$

Here  $s_1^2$  is the variance between strata mean values and  $s_2^2$  the within-strata variance,  $N_2$  is the size of strata as the potential number of samples and  $n_2$  the number of samples taken from the stratum. The great advance of stratified sampling is that only the within-strata variance propagates into the lot average if samples are taken from every stratum. With current process analysers measurements can be taken at short time intervals and that is used in the current method to estimate the process average and its variance continuously. Within a short range (or stratum in this case) a continuous process can be locally modelled with a line. With systematic sampling after a minimum of three measurements a line can be fitted to this range and the mean and variance of the range mean calculated. That is the first stratum. When the process progresses, the calculations are repeated for the new strata and values. It is important that the quality of the final lot can be monitored on-line, especially if lots of certain sizes and demanding quality specifications are produced.

The method is tested with different kinds of simulated and real data sets. This method can be easily modified also for 2D and 3D sampling targets.

### Introduction

Variography is an excellent tool for monitoring the long-range trend of continuous processes. Pierre Gy<sup>1</sup> presented in his book a method that can be used for estimating the measurement variance of a lot mean as function of sampling frequency for different sampling modes: random, stratified, and systematic sample selections. The method involves the estimation of the intercept (also called the nugget effect) of the variogram at time point zero, and numerical integration of the variogram. The method can also be used for optimizing sampling plans. At the time when variography was developed on-line analysers were not available. Samples were extracted from the process streams and analysed in laboratories. It was important to optimise the sampling plans to control the analytical costs and the reliability of the plans in estimating the estimation error. Variography is an excellent tool for that purpose. More than thirty or forty samples had to be analysed for a reliable variogram. Variograms and the variance estimates derived from variograms present average properties of the investigated lot from the time interval that the variogram covers. Therefore, the results cannot be used on-line.

Minkkinen & Paakkunainen<sup>2</sup> have presented an optional method for variographic analysis. That method has been further developed in this study. Currently process analysers are widely used to monitor continuous processes. Like in the variographic analysis the estimation of the variance of the lot mean is also in this method based on the theory of stratified

sampling. If the lot is divided into  $N_1$  strata of equal sizes (or sublots) of which  $n_1$  are sampled, the variance of the lot mean  $a_L$  is

$$s_{a_L}^2 = \frac{N_1 - n_1}{N_1 - 1} \cdot \frac{s_1^2}{n_1} + \frac{N_2 - n_2}{N_2 - 1} \cdot \frac{s_2^2}{n_1 \cdot n_2} \approx \frac{s_2^2}{n_1 \cdot n_2}, \text{ if } N_1 = n_1 \text{ and } N_2 \gg n_2 \quad (1)$$

Here  $s_1^2$  is the variance between strata mean values and  $s_2^2$  the within-strata variance,  $N_2$  is the size of strata as the potential number of samples and  $n_2$  the number of samples taken from the stratum. If samples are taken from every stratum only the within-strata variance propagates into the lot average, because  $N_1 - n_1 = 0$ . That is the great advance of stratified sampling. With current process analysers, measurements can be taken at short time intervals and that is used in the current method to estimate the process average and its variance continuously. Within a short range (or stratum in this case) a continuous process can be locally modelled with a line. With systematic sampling after a minimum of three measurements a line can be fitted to this range and the mean and variance of the range mean calculated. That is the first stratum. When the process progresses, the calculations are repeated for the new strata and values. When lots of certain sizes and demanding quality specifications are produced, it is important that the quality of the final lot can be monitored on-line. That makes it possible to classify the product based on the quality.

The method is tested with different kinds of simulated and real data sets. This same method is easy to modify also for 2D and 3D sampling targets.

## Principle of the method

With modern process analysers measurements can be taken at short intervals. In chemical processes where large quantities are processed, changes in average process values are slow. As the consequence of this, within short time intervals the changes can be effectively modelled with linear models fitted to the measurement results within the intervals. These short intervals can be treated as sublots forming the total lot monitored. From the predicted values and residuals, i.e., from the differences between the measured and predicted values, the estimates of the residual variances and the variances of the subplot mean values can be estimated as shown below.

### Local modelling of continuous data

In the following presentation the equations are written using the MATLAB style. A set of measurements  $a_i$  along time or distance axes with a constant lag between measurements can be presented as vector  $\mathbf{y} = [a_1, a_2, \dots, a_{n_L}]$ , where  $n_L$  is number of measurements within the lot. Fitting a line to sublots of two consecutive measurements (systematic sampling) is done as follows:

$$\mathbf{X} = \begin{bmatrix} 1 & 1 \\ 1 & 2 \end{bmatrix}, \quad \mathbf{Y} = \begin{bmatrix} a_1 & a_2 & \dots & a_{n-1} \\ a_2 & a_3 & \dots & a_{n_L} \end{bmatrix}, \quad (2)$$

$$\text{Regression coefficients } \mathbf{B} = \mathbf{X} \backslash \mathbf{Y} = \begin{bmatrix} b_{11} & b_{21} & \dots & b_{n_L-1,1} \\ b_{12} & b_{22} & \dots & b_{n_L,2} \end{bmatrix} \quad (3)$$

$$\text{Predicted values of } \mathbf{Y}_{pred} = \mathbf{X} \cdot \mathbf{B} \quad (4)$$

$$\text{The mean values of the substrata of duplicates are: } \text{mean}(\mathbf{Y}) = \bar{\mathbf{Y}}_j = [\bar{a}_1, \bar{a}_2, \dots, \bar{a}_{n_L-1}] = \text{mean}(\mathbf{X}) \cdot \mathbf{B} \quad (5)$$

The variances of substrata  $j = 1 \dots n_L - 1$  are  $s_j^2 = \text{var}(\mathbf{Y})$  and the relative variances are  $s_{r_j}^2 = \frac{s_j^2}{\bar{a}_j}$ .

The variance of the mean value of each stratum  $j$  for duplicates is:  $s_{\bar{a}_j}^2 = s_j^2 / 2$ .

The slopes of the lines fitted to duplicates are equal to the differences:  $\mathbf{B}(2,:) = \mathbf{Y}(1,:) - \mathbf{Y}(2,:)$  and  $\text{mean}(\text{var}(\mathbf{Y}))$  and  $\text{mean}(\mathbf{B}(2, j)^2) / 2$  are equal to the value of the variogram for lag = 1.

From duplicates it is possible to get the estimates of the total variances of sublots of 1 lag and their pooled value for the total lot.

The variance of the duplicates  $\text{var}(\mathbf{Y}(:, j)) = s_j^2 \approx s_{short}^2 + s_{trend}^2$ . If the trend within the lag is approximately constant, i.e., the slope is approximately constant and  $s_{trend}^2 \approx 0$ , from duplicates it is possible to estimate only  $s_j^2$ . The variance estimate  $s_{short}^2 \approx s_{FSE}^2 + s_{anal}^2$ , is the sum of the fundamental sampling variance and analytical variance. If the properties and concentrations of the particles in the mixture are known,  $s_{FSE}^2$  can be estimated theoretically (in variographic analysis this is usually called the variance of the nugget effect,  $v_0$ ). Many publications recommend that the nugget effect of the variograms is estimated experimentally by fitting a line to five to ten first variogram points and extrapolating it to lag zero. That is an easy but unreliable method as was shown by Heikka & Minkkinen<sup>4</sup> and Minkkinen<sup>3</sup>.

The observation vector can be folded into the  $\mathbf{Y}$  matrix containing more than two rows as follows. If  $n_L$  is the length of the  $\mathbf{y}$  vector and it is folded to  $\mathbf{Y}$  having  $i = 1 \dots j$  rows;  $\mathbf{X}$  must be modified accordingly. Again, the columns of  $\mathbf{X}$  can be used for all substrata, i.e., the columns of  $\mathbf{Y}$  of the lot.

$$\mathbf{X} = \begin{bmatrix} 1 & 1 \\ 1 & 2 \\ 1 & \dots \\ \dots & \dots \\ 1 & j-1 \\ 1 & j \end{bmatrix} \quad \mathbf{Y} = \begin{bmatrix} a_1, a_2, \dots, a_{n_L-j+1} \\ a_2, a_3, \dots, a_{n_L-j+2} \\ \dots \\ \dots \\ a_{j-1}, a_j, \dots, a_{n_L-1} \\ a_j, a_{j+1}, \dots, a_{n_L} \end{bmatrix} \tag{6}$$

The regression coefficients of lines fitted to substrata (columns of  $\mathbf{Y}$ ) together with predicted values are again obtained from equations (3) and (4):  $\mathbf{B} = \mathbf{X} \backslash \mathbf{Y} = \begin{bmatrix} b_{11} & b_{21}, \dots, b_{n-1,1} \\ b_{12} & b_{22}, \dots, b_{n,2} \end{bmatrix}$  and  $\mathbf{Y}_{pred} = \mathbf{X} \cdot \mathbf{B}$ , and the mean values of the strata (=columns) of  $\mathbf{Y}$  are obtained using Eq. (5). The difference to the previous case is that we can also calculate the residual (measured – predicted) matrix  $\mathbf{E}$ :

$$\mathbf{E} = \mathbf{Y} - \mathbf{Y}_{pred} \tag{7}$$

From the residuals, the residual variance for each substratum  $j$  can be calculated:

$$s_j^2 = \text{sum}(\mathbf{E}(:,j)) / (j - 2) \tag{8}$$

The predicted mean values of the substrata  $j$  are  $[\bar{a}_1, \bar{a}_2, \dots, \bar{a}_{n_L-l+1}]$  and are again calculated by using Eq. (5).

The variances of the strata midpoints are

$$s_{\bar{a}_j}^2 = s_j^2 / j \tag{9}$$

After the first  $j$  measurements of the lot are available, a line can be fitted to the first column of the matrix  $\mathbf{Y}$  and the mean  $\bar{a}_{j=1}$ , residual variance  $s_{j=1}^2$  and variance of the subplot mean,  $s_{\bar{a}_{j=1}}^2 = s_{j=1}^2 / j$ , can be calculated. If the measurement vector is folded according to the Eq. (6) after each new measurement, a new stratum can be added to  $\mathbf{Y}$ . Calculating the mean of the substrata  $j$  at the midpoint of the range  $j$  largely removes the effect of autocorrelation. When the process progresses a new mean can be obtained as the mean value of the strata covering the ranges from subplot 1 to the last value included in the lot that is monitored. As every stratum has the mean and standard deviation according to the Eq. (1), the between-strata variance is eliminated from the variance of the lot mean and only the within strata variances propagate into the lot mean. When new sub-lots are completed, cumulative values can easily be calculated, e.g., by using the following short MATLAB code where  $\text{aLj}(1:j)$  are the predicted mean values of subplot midpoints from Eq. (5) and  $\text{varaLcum}(j)$  the variance of lot mean as function number of strata  $j$ :

```
for j = 1 : n_L - j + 1,
    aLcum(j) = mean(aLj(1:j));
    varaLcum(j) = mean(s2aj)/j;
end
```

In the following section examples with some simulated and real data sets are analysed with this new proposed method. For comparison, results are also calculated ignoring autocorrelation. The notation used in presenting results in the examples are:

Process mean value and variance ignoring autocorrelation are:  $a_L = \text{mean}([a_1, a_2, \dots, a_{n_L}])$  and  $s_a^2 = \text{var}([a_1, a_2, \dots, a_{n_L}])$ . If the autocorrelation is not taken into account, the variance of the process mean is calculated as function of the number of samples using Eq. 10.

$$s_{a_L}^2 = s_a^2 / n_L \tag{10}$$

### Examples

**Example 1** is a simulated data set presenting a process with linear drift. The process and the results modelling the process with moving windows of three observations are shown in Fig. 1. It shows the line presenting a time interval from a linearly increasing process and 30 measurements with random noise presenting a nugget effect (sum of the fundamental sampling error + analytical error of the measurements). Fig. 1 shows also the variogram and the variance estimates for systematic sampling estimated from the variogram using Gy's method. When a line was fitted to seven first values of the variogram, extrapolation to lag = 0 gave for  $V_0$  a negative value. As the variance estimate cannot be negative, a value  $V_0 = 0$  was used in estimating the variance estimates corrected for autocorrelation for the systematic sampling mode.

If the process is linear, the detrending (or correction for autocorrelation) can be made by fitting the line to all measurement points and calculating the measurement variance from the residuals,  $\mathbf{Y} = [a_1; a_2; \dots; a_{n_L}]$  in Eq (6).

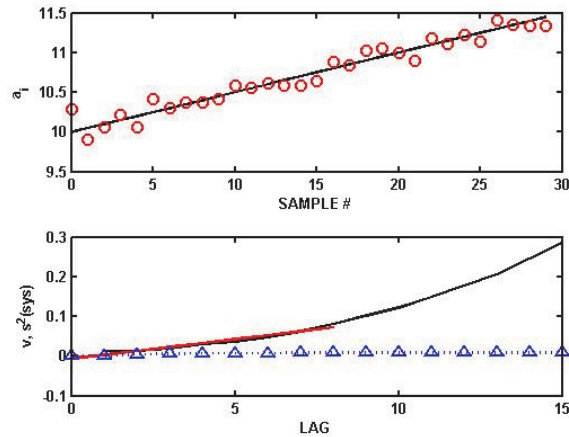

Figure 1. Example of a linear process with measurement noise (upper panel). The lower panel shows the variogram. The variogram extrapolated to lag zero gives a negative value. Therefore  $V_0 = 0$  was used in calculating the variance values for systematic sampling (triangles).

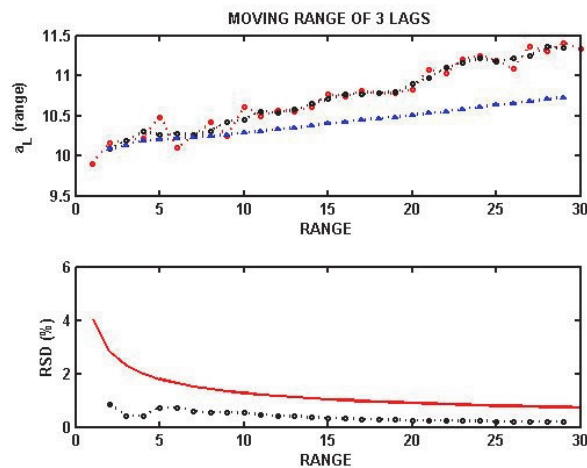

Figure 2. The upper panel shows 30 measurements from the simulated linear process (red dots) and mean of moving windows of 3 lags. The lower line shows the moving average as function of increasing range. The lower panel shows the relative standard deviation as a function of the number of measurements; the upper (red line) ignores the autocorrelation and in the lower panel the relative standard deviation is estimated with the current method from the consecutive moving windows of three measurements.

The upper panel of Fig. 2 shows the measurements, mean values of the moving windows of three measurements, and the moving lot mean as a function of measurement, or increasing range monitored. The lower panel of the figure shows, for comparison, two relative standard deviation estimates as a function of the number of measurements. Many sampling guides even today ignore the effect of autocorrelation and evaluate the mean and the uncertainty of the mean based on random distributions like normal, binomial or Poisson distributions. The figure presents both estimates. Table 1 shows the summary of the results of this experiment. The difference of the uncertainty estimates is large: The relative standard deviation of the mean,  $a_L$ , of 30 measurements is clear: 0.73 % ignoring the autocorrelation and 0.0107 % estimated from the residuals from strata of three measurements using the proposed method. The variogram gave a lower value, 0.098 % because the extrapolation of the variogram to lag zero underestimated the value of  $V_0$ .

**Example 2** presents the results of a simulated periodic process, also contaminated with a random noise. Table 2 gives the summary of this process. This data was analysed by using variography. The variogram up to lag 20 and the estimates of variance of the systematic sampling as function of sampling lag are presented in Fig. 3. In this case extrapolation to lag zero gave a negative value instead of the expected design value of 0.0165.  $V_0 = 0$  was used as the nugget value also in this case for estimating the variance of systematic sampling by using Gy's method. Gy's estimate of the relative standard deviation with lag 1 for the mean of 80 measurements was 0.073%. Estimated from the residuals the result was 0.085 %.

Fig. 4 shows 80 of the first measurements from the simulated process, the mean values of moving windows of three measurements, and the relative standard deviation estimates of the lot of using the current method and ignoring the autocorrelation.

**Table 1. Properties of the linear simulated data set analysed in Example 1. Ignoring the autocorrelation, the relative standard deviation of the total Lot of 30 measurements is 0.73 %. Estimated from the residuals of the line fitted to all 30 measurements it is 0.17 %.  $V_0$  is the variance (nugget effect) obtained by extrapolation of the variogram to lag = 0. Estimated from the variogram by Gy’s method the relative standard deviation estimate is 0.098 %.**

STATISTICS	MEAN	VARIANCE
NOISELESS PROCESS	10.725	0.194
NOISE	0	0.0108
TOTAL, $s_a^2$	10.729	0.184
FROM RESIDUALS		0.0107
$V_0$ (EXTRAP)	-0.0065	
RSD estimates assuming randomness: $100 \frac{\sqrt{0.184/30}}{10.725} \% = 0.73\%$		
RSD from residuals: $100 \frac{\sqrt{0.0107/30}}{10.725} \% = 0.17\%$		

**Table 2. Properties of the cyclic simulated data set analysed in Example 2. The  $V_0$  estimate was obtained by extrapolation to lag = 0. The relative standard deviation of the total Lot of 80 measurements is 0.085 % estimated by the current method, and 0.073 % estimated by Gy’s method from the variogram. If the autocorrelation is ignored the relative standard deviation estimate is 0.81 %.**

STATISTICS	MEAN	VARIANCE
NOISELESS PROCESS	10.000	0.5063
NOISE	0.0055	0.0165
TOTAL, $s_a^2$	10.0055	0.5304
FROM RESIDUALS		$7.35 \times 10^{-5}$
$V_0$ (EXTRAP)	-0.13	
RSD estimates assuming randomness: $100 \frac{\sqrt{0.5304/80}}{10.0055} \% = 0.81\%$		
RSD from residuals: $100 \frac{\sqrt{7.35 \times 10^{-5}/80}}{10.0055} \% = 0.085\%$		

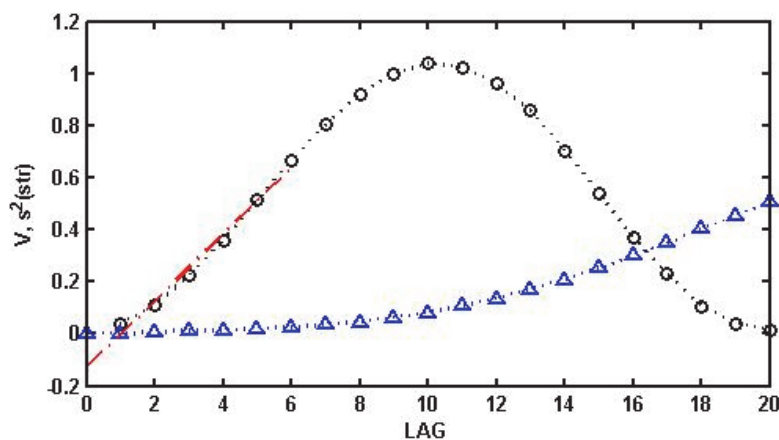

**Figure 3. Absolute variogram of the periodic process up to lag 20 and extrapolation to  $V_0$  together with the variance estimates for systematic sampling.**

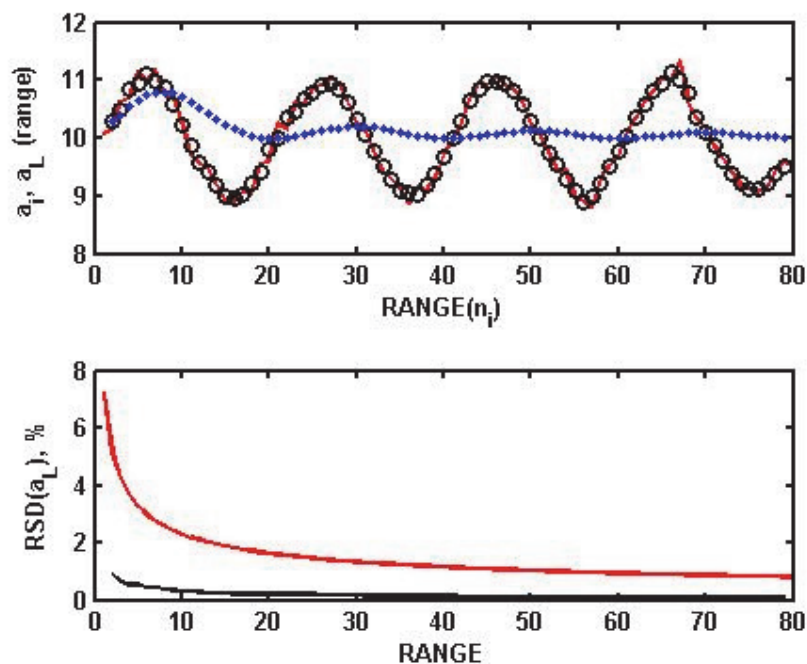

**Figure 4.** Upper panel: Process values (red line) and mean values of the windows of three measurements (black circles) and moving average as function of increasing range. Lower panel: Relative standard deviation estimates ignoring the autocorrelation (upper line) and the estimates with current method (lower line) as a function of increasing range.

**Example 3:** Data for this example was taken from the study carefully analysed by using variography in references<sup>5-7</sup>. In that study 100 samples were taken during unloading from a shipload of soybeans. Samples were analysed for genetically modified material (GMO). In the European Union the material must be labelled as GMO containing material if the content exceeds 1 %. 0.9 % has been used as the decision limit for acceptance. It is supposed to give a 95% confidence that the true value does not exceed 1 %. Most sampling guides recommend that sample numbers of 4 to 8 is sufficient. That is illusory. With the segregation pattern of this example, in the above-mentioned references<sup>5-7</sup>, with a sample size of 3000 beans the minimum number of samples (or increments making a composite sample) is 42.

Figure 5 presents the analytical results ( $a_i$ ) as the relative heterogeneity contributions:  $h_i = (a_{i+lag} - a_i)/a_L$  the relative variogram calculated from the heterogeneities. The concentration of GMO material shows high variability. This is a good data set to demonstrate the value of the method proposed here. If the concentration of the analyte can be measured on-line, the average quality of the process can be evaluated in real time and the product could be classified based on the average quality. This example shows what could be achieved with on-line measurement of the GMO content if such a technology were available. In this example the quality was estimated after each twenty samples taken (equivalent of dividing the cargo during unloading into five sub-loads). The results are presented in Figures 6 -10 and in Table 3.

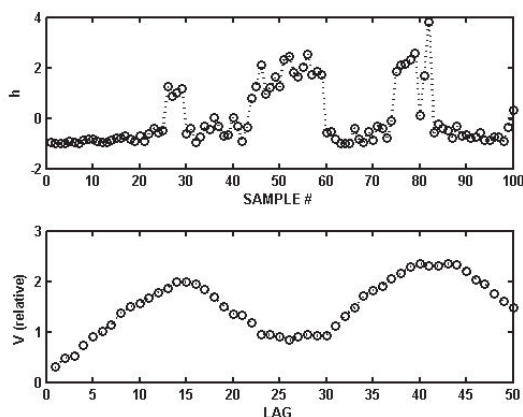

**Figure 5.** Relative heterogeneity contributions of GMO in 100 samples taken during unloading a shipload of soybeans together with the variogram.

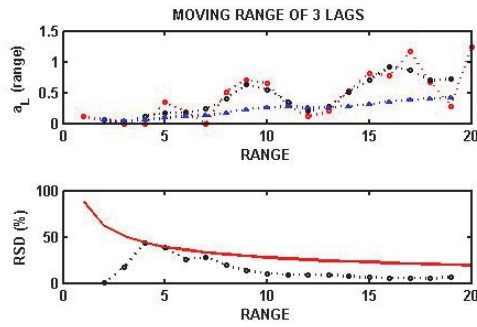

Figure 6. Measurements and moving mean calculated from three sample windows of the first substratum consisting of twenty samples (upper panel). The lower panel shows the relative standard deviation estimate of the moving mean. The continuous line shows the results if autocorrelation is ignored and the dotted line the results calculated from the residuals.

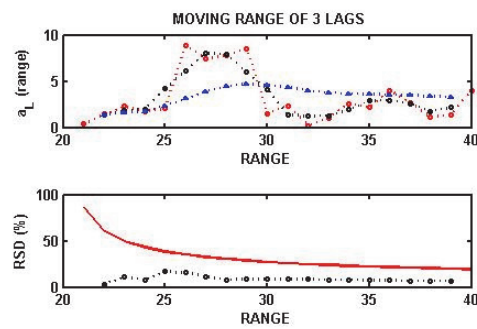

Figure 7. Results of the second stratum of twenty samples.

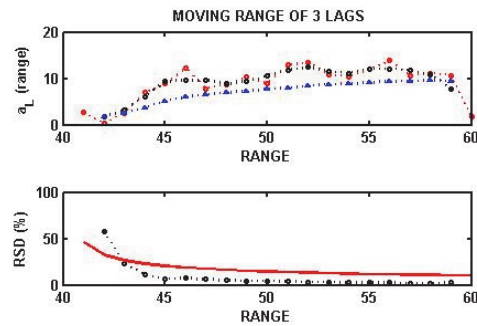

Figure 8. Results of the third stratum of twenty samples.

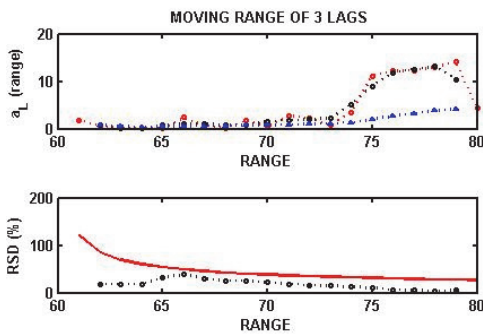

Figure 9. Results of the fourth stratum of twenty samples.



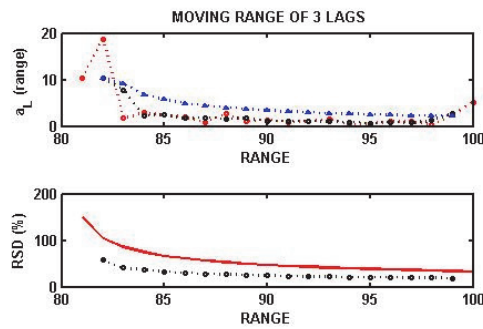

Figure 10. Results of the fifth stratum of twenty samples.

Table 3. Summary of GMO example

RANGE	MEAN (%)	VARIANCES		RSD %	
		var( $a_i$ )	From residuals	From var( $a_i$ )	From residuals
1 - 20	0.423	0.1431	0.0392	19.6	11.0
21 - 40	3.32	7.5	2.62	19.3	11.5
41 - 60	9.47	16.4	2.82	10.2	4.18
61 - 80	4.19	25.9	2.39	26.9	8.70
81 - 100	2.29	19.1	9.44	33.2	31.6
Mean of ranges	3.94	13.8	3.46	9.4	11.1
1 - 100	3.96	21.0	3.80	11.6	13.4
$V_0(\text{EXTRAP})$	-0.13				

This example shows the advantage of on-line measurements in monitoring continuous processes, raw materials and/or products. When analytical results are obtained with short intervals, the role of random error can be filtered from the estimation of the lot mean. A great advantage is, if a product with high quality specifications is manufactured, it can be continuously classified to product lots according to the quality. Like in this example, the average concentration of the first fifth of the cargo unloaded from the ship is 0.423 %, well below 1 %, and could be labelled as non-GMO material.

**Example 4:** Data for this example consisted of 100 process analyser measurements of one of the components at 10 min intervals from the feed to a flotation plant. The variance plot clearly shows the noisy parts of the process and the moving mean plot how the noisy parts affect the mean of the lot. That can be valuable diagnostic information for process control.

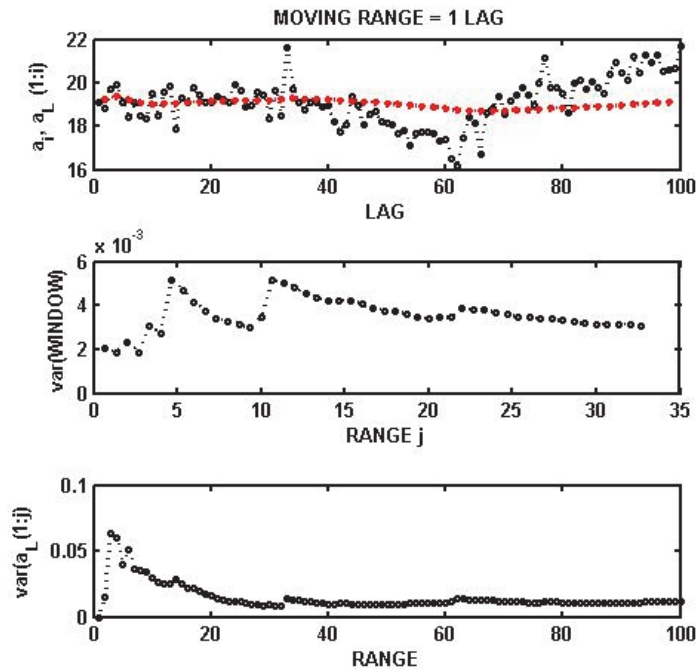

**Figure 11. Results of a range of 100 process analyser measurements from a feed to a flotation plant. The sampling interval used was 15 min covering a total of 25 production hours. The top panel shows the analyser results and the middle panel the residual variance,  $s_j^2$ , of the windows of  $j$  measurements. The lowest panel shows the variance of the mean of the moving average.**

### Modification of the method to 2-dimensional lots

It is easy to modify this method to handle also 2-D lots. If the samples have been taken at regular grids, a plane can be fitted to squares taken from the grid. **X** and **Y** need to be redefined:

$$\mathbf{X} = \begin{bmatrix} 1 & 1 & 1 \\ 1 & 1 & 2 \\ 1 & 2 & 1 \\ 1 & 2 & 2 \end{bmatrix} \quad \mathbf{Y} = \begin{bmatrix} a_{11} \\ a_{12} \\ a_{21} \\ a_{22} \end{bmatrix}$$

The second and third row of **X** are the coordinates of the corners of a square on the plane from which the samples are taken and **Y** the vector of the corresponding analytical results. Otherwise, the equations used for the 1-D case apply. Modification for a 3-D case can be done the same way. For a more complicated sampling grid it is possible to use experimental designs.

### Summary

Variography is very useful and a well-established method to analyse the long-range variability of 1-D processes. It can provide variance estimates for different sampling modes corrected for autocorrelation and for optimising the sampling interval when samples are cut from the process streams for laboratory analysis. The results are usually available long after a certain lot is produced. The results are also based on the average values of the process.

Process analysers on the other hand can produce results at high frequency. If the traditional variography is used for estimating the sampling variance of the lot, only a part of the data is used. The method proposed here gives the results, variance and mean of the progressing lot in real time. This is especially useful if the product has strict quality specifications (e.g., medicals, foodstuff, fertilizers). If the product is delivered in containers or big bags, they can be assigned individual certificates of their content.

While with increasing number of measurements the effect of the random part of the measurement error becomes insignificant in the lot average, that does not eliminate the systematic errors. A lot of process analysers are based on different spectroscopic techniques which get information only from a thin layer of the process stream. That can be a problem when materials which have a high tendency to segregate are analysed. When such materials, like crushed particles or powders on conveyor belts, are analysed and complete cross-sections cannot be sampled, the only solution is to randomize, if possible, the material at the point where the process analyser is installed. If that is not possible, material balance calculations cannot be based on process analyser results. Still, the results can be useful in monitoring the process behaviour with time.

## References

1. P. M. Gy, *Sampling of Heterogeneous and Dynamic Material Systems, Theories of Heterogeneity, Sampling and Homogenizing*. Elsevier, Amsterdam, (1992).
2. P. Minkkinen and M. Paakkunainen, "Direct Estimation of Sampling Variance from Time Series Measurements – Comparison to Variographic Analysis", in *Proceedings 2nd World Conference on Sampling and Blending (WCSB2)*. AusIMM, pp.39-44 (2005).
3. R. Heikka and P. Minkkinen, "Comparison of some methods to estimate the limiting value of the variogram  $v_h(j)$  for the sampling interval  $j = 0$  in sampling error estimation", *ACA*, **346**, 277-283 (1997).
4. P. Minkkinen, "Properties of Process Variograms", in *Proceedings 6th World Conference on Sampling and Blending (WCSB6)*. AusIMM, pp.241-248 (2013).
5. K. H. Esbensen, C. Paoletti and P. Minkkinen, "Representative Sampling of Large Kernel Lots, Part I - Theory of Sampling and variographic analysis", *TrAC* **32**, 154-164 (2012).
6. P. Minkkinen, K. H. Esbensen and C. Paoletti, "Representative Sampling of Large Kernel Lots, Part II - Application to Soy Bean Sampling for GMO Control", *TrAC* **32**, 165-177 (2012).
7. K. H. Esbensen, C. Paoletti and P. Minkkinen, "Representative Sampling of Large Kernel Lots, Part III - General Considerations on sampling heterogeneous foods", *TrAC* **32**, 178-184 (2012).

## Challenges in Quality Assurance and Quality Control Systems Development

Neressa Sukha

144 Oxford Road, Rosebank, Johannesburg, South Africa E-mail: neressa.sukha@angloamerican.com

**Quality Assurance and Quality Control (QA/QC) is of critical interest in the mining industry. Over the years, Anglo American Platinum has adopted a sound strategy of Best Practice Principles (BPP) for mass measurement, sampling, sample preparation, analysis, and metal accounting. Often, much effort is focused on implementation and maintenance of quality control systems to provide quality assurance. Within the Anglo American Platinum business units, QA/QC data are deemed of significant value on a day-to-day basis and on a higher level also provides a means to prove or disprove evaluation and metal accounting disputes between various sites and/or opposing members of the Joint Evaluation Committee (JEC). Unfortunately, QA/QC data and associated QA/QC systems alone do not always provide the technical or tangible reasons to supplement explanations around anomalies in performance. It is sometimes necessary to go beyond monitoring and focus on interpreting the QA/QC data to comprehend the underlying issues. This paper aims to showcase a multitude of actual case studies pertaining to troubleshooting of challenges encountered throughout the Platinum processing pipeline (i.e., Concentrator to Smelter to Refinery). These challenges range from areas of mass measurement to sampling, to sample preparation and analytical as well as plant performance. Observations and learnings from these instances indicated that even though stringent QA/QC was adhered to, it was evident that complying to first principles of mass measurement and sampling theory, minimum sample mass and an ongoing understanding of individual material characteristics was crucial. It was also highlighted that the re-assessment of designs, methods and protocols are necessary per material stream and that a standardization approach across all Anglo American Platinum business units is perhaps sensible at one time but may not always be appropriate and/or relevant.**

### Introduction

Anglo American Platinum operations are divided into mining and process respectively. The mining end comprises of open pit and underground mining, while the process end comprises of Concentrator Plants (fully owned and joint ventures), four Smelters, one Base Metal Refinery (BMR) and one Precious Metal Refinery (PMR). UG2, Merensky, Platreef and Great Dyke ore reefs are mined and processed to produce final products including precious metals as well as base metals. The Group Evaluation, Metal Accounting and Analytical (GEMA) team reside within the Anglo American Platinum corporate function and high-level responsibilities include ensuring that risk is mitigated through governance of the evaluation, analytical and metal accounting entities with strict adherence to the AMIRA Code of Practice P754<sup>1</sup>. Frequent evaluation meetings are held between site personnel and GEMA to discuss the trended quality control data and maintain quality assurance.

With current economic pressures, Lomborg<sup>2</sup> succinctly emphasizes the challenges with exploration and exploitation of Platinum Group Element (PGE) deposits since the very low ore grades hover around the detection limits of analytical techniques and factors such as the nugget effect. Bhattacharya, Islam, Kumar & Santosh<sup>3</sup> further mentions that the practice of statistical quality control in the minerals industry is very limited and variable but can be a somewhat promising technique in terms of quality assurance. According to Simon & Gosson<sup>4</sup> quality assurance and quality control are the two major components of any quality management system. Consistent with the ISO definition, quality assurance is 'the assembly of all planned and systematic actions necessary to provide adequate confidence that a product, process, or service will satisfy given quality requirements,' and quality control refers to 'the operational techniques and activities that are used to satisfy quality requirements.'

Quality control plays a significant role in ensuring quality assurance; however, in certain instances quality control systems provide only a means to consolidate important information in a concise manner without really detecting the problem or non-conformance. This paper focuses on actual case studies within the Anglo American Platinum Concentrator Plants and Smelters.

### Case Study A: Weighbridge mass reconciliation

Wet filtered concentrate material is transported by flexi-side tipper trucks from various Concentrator Plants to the Smelters within the Platinum Group. In this instance, multiple concentrate streams were directed to one particular Smelter in question. The wet mass comparison on gross mass was performed between the Sender and Receiver sites to reconcile masses for metal accounting purposes. The relative difference between the gross masses were calculated and trended as per norm. Figure 1 below illustrates the gross mass comparison for Stream A over a period.

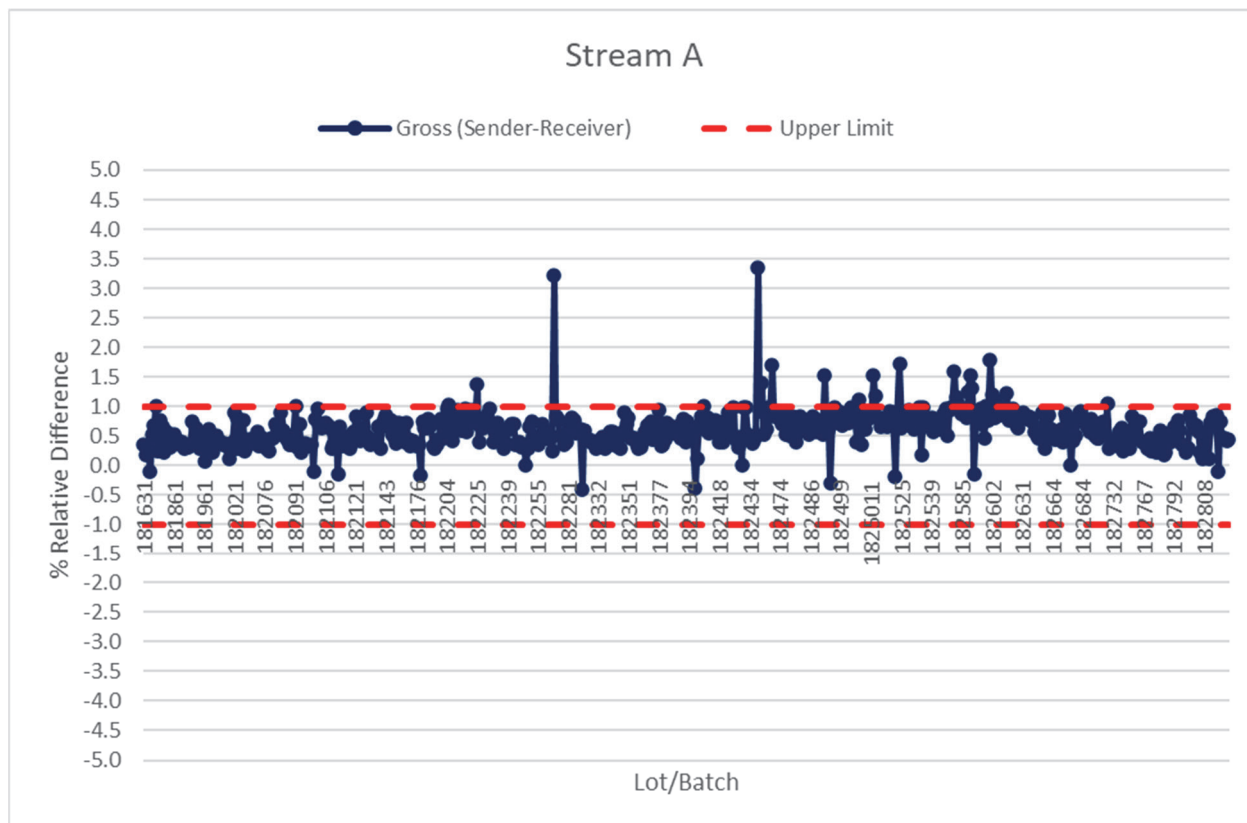

**Figure 1. Gross Mass Comparison for Stream A.**

The % relative difference between the Sender and Receiver was generally within the control limit of  $\pm 1\%$  set by Group Metal Accounting and thus the site metal accountant did not immediately raise any concerns. However, after further discussion at an evaluation meeting, it was agreed that a bias clearly existed with the Sender site weighbridge consistently reading higher masses than that of the Receiver site. Even though a quality control system was in place, this did not ensure that the problem was identified, investigated, and resolved immediately. In addition to this, the Receiver site also consolidates weighbridge mass data via an automated system. The system is setup to pre-calculate the % relative difference and if exceeded, security personnel and the site super user need to investigate further. Upon discussion with site personnel, it was clear that a gap existed between the amount of these occurrences and the implication thereof.

Bi-monthly weighbridge checks using certified weights is a Group Standard and this site had deviated from this and therefore there was no way of confirming if the Receiver's weighbridge was accurate or not. Further mass comparisons were performed for other incoming and outgoing streams at the Receiver site and the same pattern emerged. A full weighbridge re-calibration was then initiated, and the original equipment manufacturer conducted the calibration. Prior to calibration, the weighbridge and associated parts were inspected. It was found that one of the load cells which contribute to the overall truck gross mass value was defective. The defective load cell was subsequently replaced, and the data post calibration was trended. Figure 2 below illustrates the mass comparison for Stream A before and after the weighbridge load cell replacement and re-calibration.

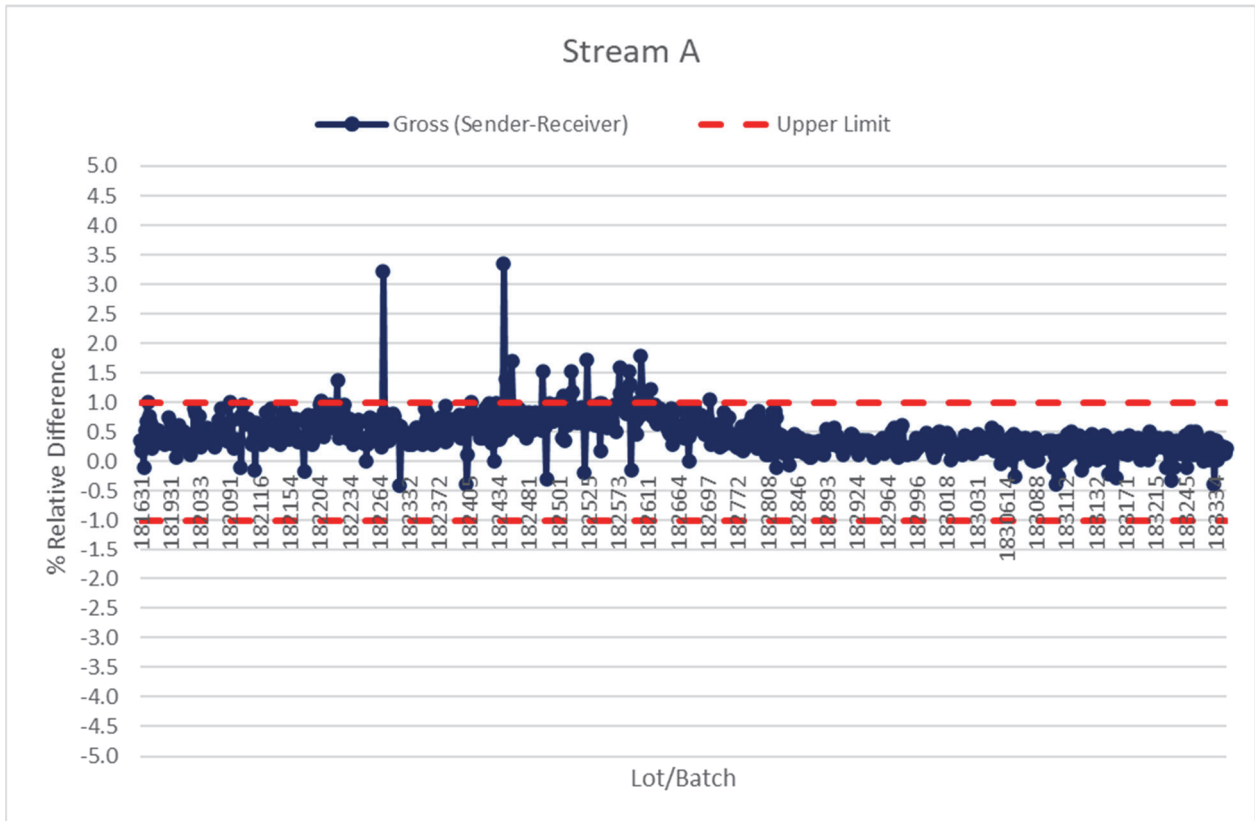

**Figure 2. Gross Mass Comparison for Stream A after Re-calibration.**

Having replaced one load cell and re-calibrating the weighbridge lowered the % relative difference values to be unbiased and well within the control limits. Furthermore, if the bi-monthly weighbridge checks using certified test weights were done, this would have possibly outlined the problem earlier rather than later. In this case study, it is observed that systems are in place to minimize risk by monitoring and controlling certain variables; however, if the highlighted warning signs through quality control systems are not acknowledged and actioned, then one can go on without realizing the implication thereof. The possible outcome of this scenario has a domino effect. The Smelter accountability could be skewed because of under-estimation of inputs, and in-situ stock comparison with theoretical stock would not tie up. In addition, since the Smelter is deemed the Receiver and the Concentrator Plants are deemed the Sender, and the Receiver mass is the official mass used for metal accounting purposes, the Concentrator plant would also have an inflated recovery and over-accountability.

### Case Study B: Specific gravity comparison

An Anglo American Platinum Smelter receives two independent, PGM-enriched concentrate streams from two Concentrator Plants respectively. The respective concentrate streams are transported by pipe to the concentrate handling area located at the Smelter. Each concentrate stream is sampled by means of a vezin-vezin sampler combination. The primary increment is sub-sampled by the secondary vezin, and the sample is then deposited into two stationary openings 180° apart. The vezin-vezin combination is designed and operated according to the principles of Theory of Sampling, and as such representative samples are always ensured. The density of the respective concentrate streams is reported in terms of Specific Gravity (SG). An A and B sample result per daily LOT. The SG of the A sample collected during sub-sampling of the day tank is determined during sample preparation done at the Evaluation Laboratory within the Smelter. The B sample is reserved for backup purposes. In addition, an SG-determining instrument is installed on the concentrate weigh tanks of both Concentrator Plant 1 and Concentrator Plant 2. The SG from the instrument is a calculated value based on differential pressure. To date, both the sample SG and instrument SG have been trended and compared together with the % solids of the samples collected.

The contractual agreement between the Smelter and the Concentrator Plants states that a penalty may be invoked (at the discretion of the Smelter) should the average of the individual monthly SG readings obtained from the instrument SG be less than a value of 1.600. Furthermore, the instrument SG is the official SG to be reported with the % solids being the input for metal accounting purposes. Concerns were raised around the reliability and accuracy of the instrument SG data being reported. To address these concerns and assist the Smelter with a methodology to follow, sample SG and instrument SG data from November 2016 to February 2018 was analysed.

### Monthly Weighted SG – Difference between Sample and Instrument SG

A monthly weighted SG for the Plant 1 and Plant 2 streams were calculated for the Sample and Instrument, and the difference between these values was then determined. All raw data was used as part of this analysis, and no data was removed as possible.

outliers to give an overall indication of worst case scenario. Table 1 and Table 2 below provide a summary of the monthly weighted SG data for Plant 1 and Plant 2 respectively.

**Table 1. Plant 1 Monthly Weighted SG Data.**

Month	SG – Sample (Lot)	SG - Instrument	Difference (Sample - Instrument)
Nov-16	1.560	1.529	0.031
Dec-16	1.581	1.562	0.019
Jan-17	1.609	1.584	0.025
Feb-17	1.622	1.597	0.025
Mar-17	1.628	1.609	0.019
Apr-17	1.651	1.623	0.028
May-17	1.613	1.610	0.003
Jun-17	1.622	1.607	0.015
Jul-17	1.616	1.598	0.018
Aug-17	1.569	1.571	-0.002
Sep-17	1.597	1.573	0.024
Oct-17	1.614	1.586	0.028
Nov-17	1.623	1.581	0.042
Dec-17	1.553	1.568	-0.015
Jan-18	1.570	1.521	0.049
Feb-18	1.577	1.623	-0.046

Data has been factorized and site details omitted for confidentiality purposes.

**Table 2. Plant 2 Monthly Weighted SG Data.**

Month	SG – Sample (Lot)	SG - Instrument	Difference (Sample - Instrument)
Nov-16	1.564	1.605	-0.041
Dec-16	1.667	1.627	0.040
Jan-17	1.637	1.606	0.031
Feb-17	1.635	1.594	0.041
Mar-17	1.685	1.652	0.033
Apr-17	1.672	1.640	0.032
May-17	1.639	1.620	0.019
Jun-17	1.696	1.650	0.046
Jul-17	1.661	1.637	0.024
Aug-17	1.633	1.620	0.014
Sep-17	1.661	1.636	0.024
Oct-17	1.609	1.632	-0.024
Nov-17	1.623	1.581	0.042
Dec-17	1.553	1.568	-0.015
Jan-18	1.634	1.645	-0.011
Feb-18	1.621	1.637	-0.016

Data has been factorized and site details omitted for confidentiality purposes.

From Table 1, the calculated monthly weighted Plant 1 SG for the Instrument was less than 1.600 for November and December 2016, January, February, July – December 2017 and January 2018.

From Table 2 previously, the calculated monthly weighted Plant 2 SG for the Sample was less than 1.600 for February, November and December 2017. It appears from the data in Table 1 and Table 2, that the Plant 2 stream delivers a higher and more consistent SG than that of the Plant 1 stream. It is also notable that the Instrument for intermittent periods generally reports a lower SG than that of the Sample SG for both Plant 1 and Plant 2 streams. A possible reason for this may be that settling of solids is present in the weigh tanks and therefore the solids present in the area below the bottom pressure probe is not accounted for. Having said this, for other time periods, the difference between the Sample SG and Instrument SG for both streams is positive and negative which indicates that a consistent bias is not present since introduction of the Instrument. One might argue however that there are consecutive periods where the difference between the Sample SG and the Instrument SG is one sided and is therefore bias. Using the monthly SG data for both methods, the Standard Deviation (SD) on the difference between the Sample SG and Instrument SG was determined for both streams. Applying the standard deviation on the difference between the Sample SG and Instrument SG resulted in the following summary as per Table 3 and 4:

**Table 3. Plant 1 Monthly Weighted SG Data – Standard Deviation on Difference of SG's.**

Month	Volume – Sample (Lot)	Instru-ment	Difference (Sample - Instrument)	1sd (calcu- lated for each month data)	+1sd	-1sd	+2sd	-2sd	+3sd	-3sd
Nov-16	1.560	1.529	0.031	0.060	PASS	PASS	PASS	PASS	PASS	PASS
Dec-16	1.581	1.562	0.019	0.090	PASS	PASS	PASS	PASS	PASS	PASS
Jan-17	1.609	1.584	0.025	0.065	PASS	PASS	PASS	PASS	PASS	PASS
Feb-17	1.622	1.597	0.025	0.082	PASS	PASS	PASS	PASS	PASS	PASS
Mar-17	1.628	1.609	0.019	0.027	PASS	PASS	PASS	PASS	PASS	PASS
Apr-17	1.651	1.623	0.028	0.074	PASS	PASS	PASS	PASS	PASS	PASS
May-17	1.613	1.610	0.003	0.074	PASS	PASS	PASS	PASS	PASS	PASS
Jun-17	1.622	1.607	0.015	0.052	PASS	PASS	PASS	PASS	PASS	PASS
Jul-17	1.616	1.598	0.018	0.029	PASS	PASS	PASS	PASS	PASS	PASS
Aug-17	1.569	1.571	-0.002	0.034	PASS	PASS	PASS	PASS	PASS	PASS
Sep-17	1.597	1.573	0.024	0.045	PASS	PASS	PASS	PASS	PASS	PASS
Oct-17	1.614	1.586	0.028	0.038	PASS	PASS	PASS	PASS	PASS	PASS
Nov-17	1.623	1.581	0.042	0.145	PASS	PASS	PASS	PASS	PASS	PASS
Dec-17	1.553	1.568	-0.015	0.135	PASS	PASS	PASS	PASS	PASS	PASS
Jan-18	1.570	1.521	0.049	0.045	FAIL	PASS	PASS	PASS	PASS	PASS
Feb-18	1.577	1.623	-0.046	0.060	PASS	PASS	PASS	PASS	PASS	PASS

**Table 4. Plant 2 Monthly Weighted SG Data – Standard Deviation on Difference of SG's.**

Month	Volume – Sample (Lot)	Instru-ment	Difference (Sample - Instrument)	1sd (calcu- lated for each month data)	+1sd	-1sd	+2sd	-2sd	+3sd	-3sd
Nov-16	1.564	1.605	-0.041	0.042	PASS	PASS	PASS	PASS	PASS	PASS
Dec-16	1.667	1.627	0.040	0.081	PASS	PASS	PASS	PASS	PASS	PASS
Jan-17	1.637	1.606	0.031	0.110	PASS	PASS	PASS	PASS	PASS	PASS
Feb-17	1.635	1.594	0.041	0.044	PASS	PASS	PASS	PASS	PASS	PASS
Mar-17	1.685	1.652	0.033	0.059	PASS	PASS	PASS	PASS	PASS	PASS
Apr-17	1.672	1.640	0.032	0.115	PASS	PASS	PASS	PASS	PASS	PASS
May-17	1.639	1.620	0.019	0.055	PASS	PASS	PASS	PASS	PASS	PASS
Jun-17	1.696	1.650	0.046	0.042	FAIL	PASS	PASS	PASS	PASS	PASS
Jul-17	1.661	1.637	0.024	0.034	PASS	PASS	PASS	PASS	PASS	PASS
Aug-17	1.633	1.620	0.014	0.039	PASS	PASS	PASS	PASS	PASS	PASS
Sep-17	1.661	1.636	0.024	0.058	PASS	PASS	PASS	PASS	PASS	PASS
Oct-17	1.609	1.632	-0.024	0.076	PASS	PASS	PASS	PASS	PASS	PASS
Nov-17	1.623	1.581	0.042	0.145	PASS	PASS	PASS	PASS	PASS	PASS
Dec-17	1.553	1.568	-0.015	0.135	PASS	PASS	PASS	PASS	PASS	PASS
Jan-18	1.634	1.645	-0.011	0.050	PASS	PASS	PASS	PASS	PASS	PASS
Feb-18	1.621	1.637	-0.016	0.026	PASS	PASS	PASS	PASS	PASS	PASS

From Table 3 and 4 respectively, only one failure is noted for Plant 1 and Plant 2 on the 1SD limit for the difference between the Sample SG and Instrument SG.

#### % Co-efficient of Variation –Sample SG and Instrument SG

The % Co-efficient of Variation (COV) was calculated for the period November 2016 to February 2018, taking into account the Sample SG data and the Instrument SG data. In general, a % COV below 5% indicates an acceptable performance. For Plant 1 and Plant 2, the % COV (with any possible outliers) were calculated as follows in Table 5:



**Table 5. %COV with Possible Outliers.**

	Plant 1	Plant 2	Target
% COV for Sample SG	5.04	5.13	5.00
% COV for Instrument SG	2.89	2.73	5.00
% COV for SG Difference (Sample SG – Instrument SG)	3.65	3.77	5.00

The Instrument SG data resulted in a lower % COV of 2.89 compared to the Sample SG % COV of 5.04% for Plant 1. Similarly, for Plant 2, the Instrument SG data resulted in a lower % COV of 2.73 compared to the Sample SG % COV of 5.13%. This indicates that the instrument performance is consistent (precise but not necessarily accurate) over a long period of time. Furthermore, the % COV for the SG difference between the Sample SG and Instrument SG was calculated to be below 5% for both streams.

For Plant 1 and Plant 2, the % COV (without outliers) were calculated as follows in Table 6:

**Table 6. %COV without Possible Outliers.**

	Plant 1	Plant 2	Target
% COV for Sample SG	3.09	3.91	5.00
% COV for Instrument SG	2.60	2.63	5.00
% COV for SG Difference (Sample SG – Instrument SG)	2.04	2.30	5.00

The SG outliers were determined by plotting a histogram of the historical data and removing the values which did not appear for more than 0.6% (frequency of less than 5 times in an excess of 400 data points) of the total data points. Again, the same conclusion around the Instrument SG performance was noted as per above.

#### Variograms: Sample SG vs. Instrument SG

Variograms were also produced using the Sample SG data and Instrument SG data for period November 2016 to February 2018.

For Plant 1, the  $V_0$  value was 0.729 and 0.251 for the Sample and Instrument respectively indicating that the error associated with the Sample SG data is almost three times that of the Instrument SG data. Figure 3 and 4 indicates the Plant 1 variogram for the Sample and Instrument respectively.

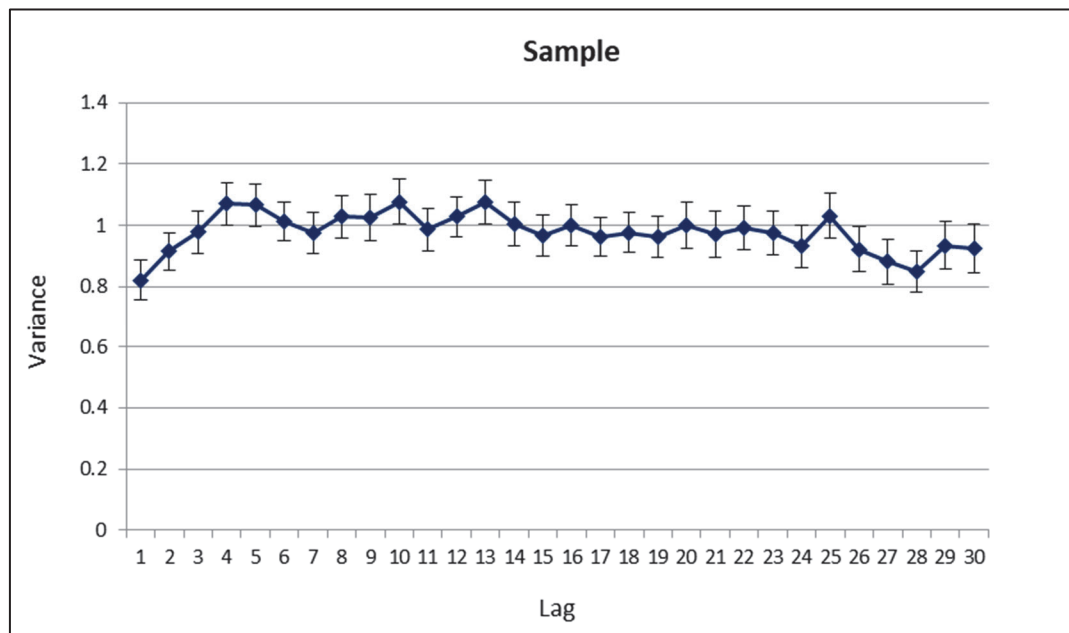
**Figure 3. Variogram for Sample SG data – Plant 1.**

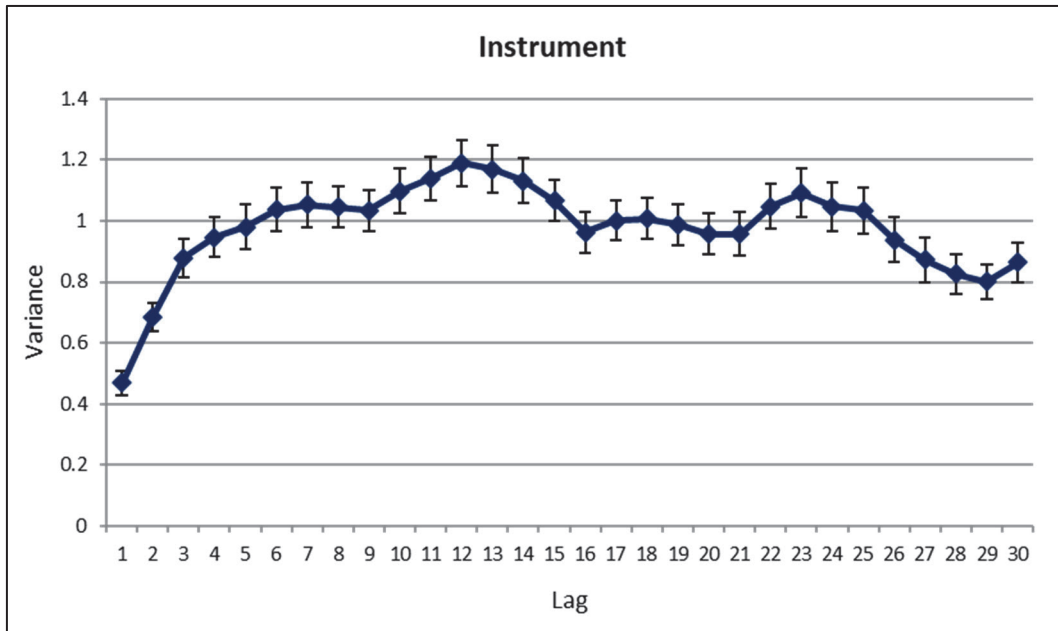

Figure 4. Variogram for Instrument SG data – Plant 1.

For Plant 2, the  $V_0$  value was 0.875 and 0.309 for the Sample and Instrument respectively indicating that the error associated with the Sample SG data is again almost three times that of the Instrument SG data. Figure 5 and 6 indicates the Plant 2 variogram for the Sample and Instrument respectively.

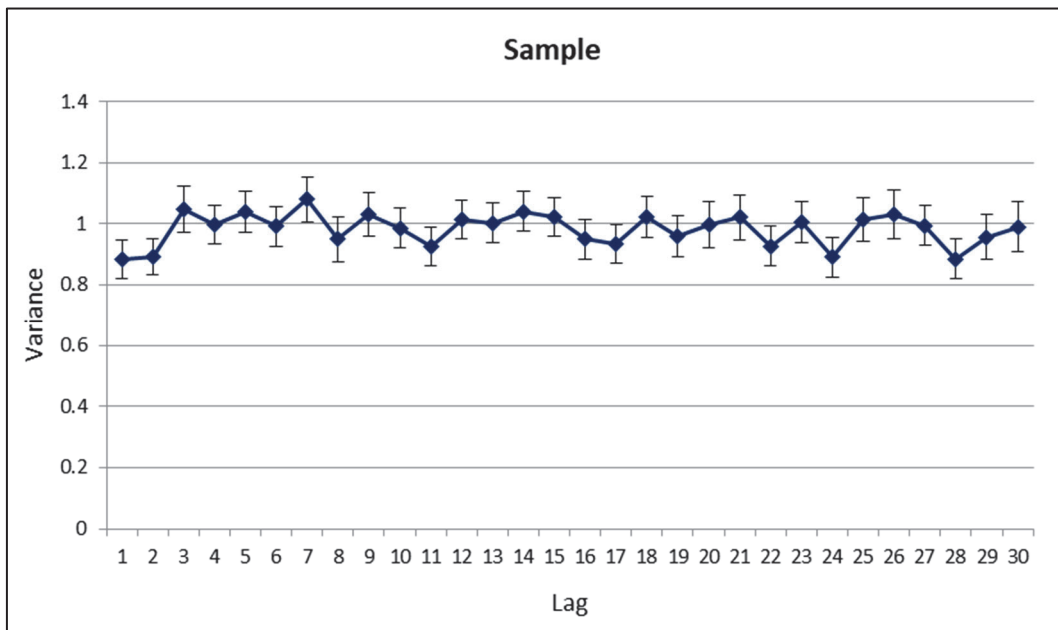

Figure 5. Variogram for Sample SG data – Plant 2.

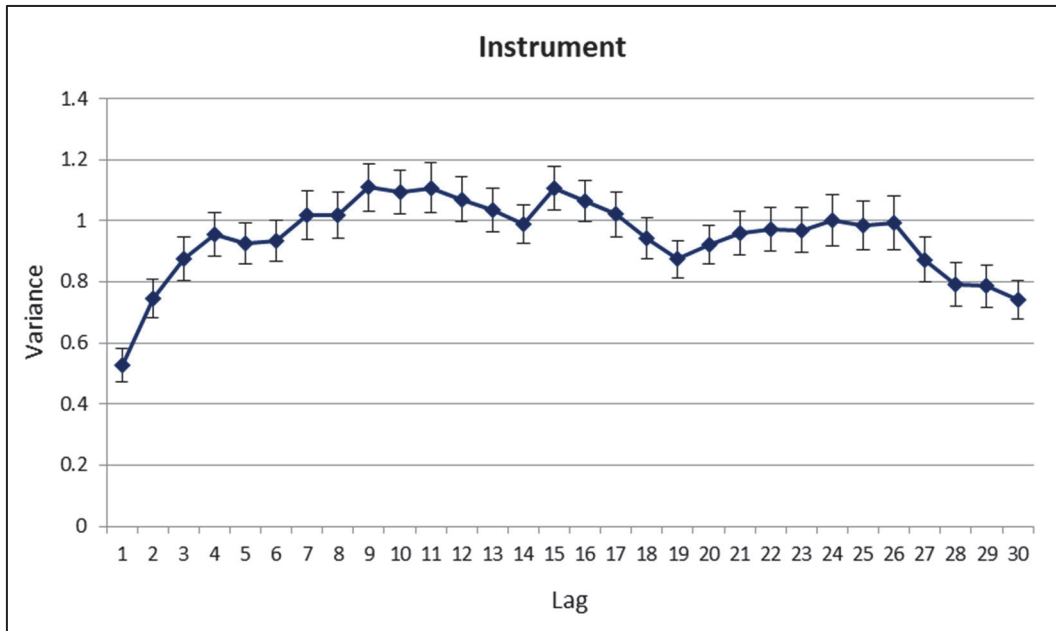

Figure 6. Variogram for Instrument SG data – Plant 2.

In both cases, the Instrument gave a better correlation (indicated by the longer lag periods) than that of the Sample. This provides confidence that the instrument can provide a more consistent and reliable SG value than that of the Sample which is prone to human errors.

Control Limits – Difference between Sample SG and Instrument SG

Control limits ( $\pm 1SD$ ,  $\pm 2SD$  &  $\pm 3SD$ ) for the difference between Sample SG and Instrument SG was determined using the data from December 2017 to February 2018 – refer to Figure 7 and 8.

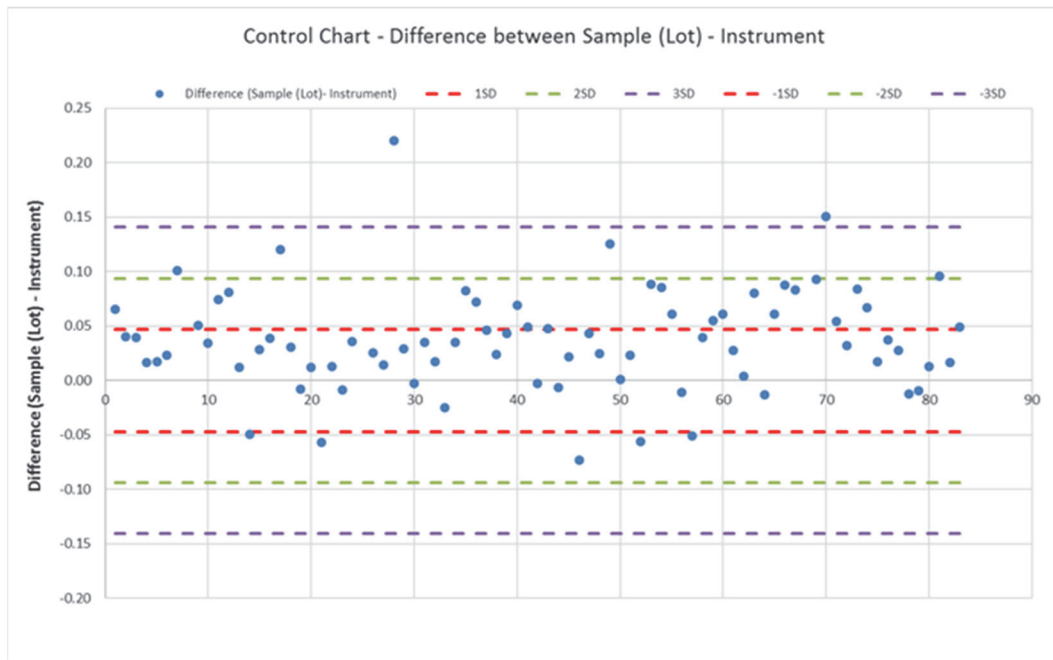

Figure 7. Control Chart – Plant 1.

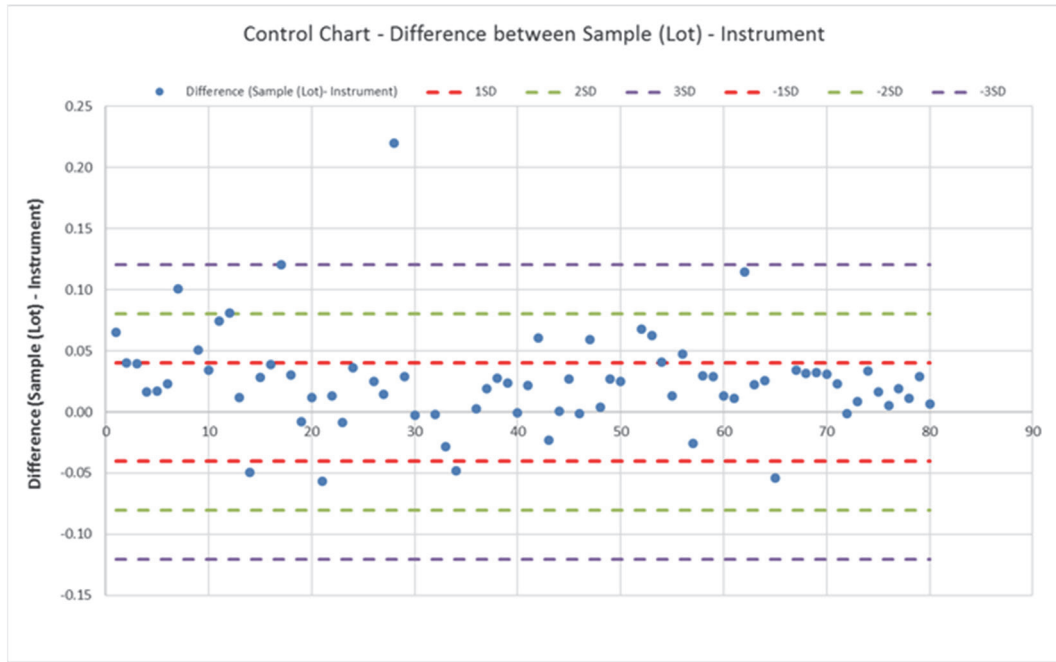

Figure 8. Control Chart – Plant 2.

The number of data points failing the respective SD limits are summarized in Table 7 and 8 below.

Table 7. Failures corresponding to Control Limits – Plant 1.

Plant 1	+1SD (PASS/FAIL)	-1SD (PASS/FAIL)	+2SD (PASS/FAIL)	-2SD (PASS/FAIL)	+3SD (PASS/FAIL)	-3SD (PASS/FAIL)
Number of Data Points - FAIL	29	5	7	0	2	0
Number of Data Points - PASS	54	78	76	83	81	83
% FAIL	34.94	6.02	8.43	0.00	2.41	0.00
% FAIL	6.83		1.41		0.40	

Table 8. Failures corresponding to Control Limits – Plant 2.

Plant 2	+1SD (PASS/FAIL)	-1SD (PASS/FAIL)	+2SD (PASS/FAIL)	-2SD (PASS/FAIL)	+3SD (PASS/FAIL)	-3SD (PASS/FAIL)
Number of Data Points - FAIL	11	1	3	0	1	0
Number of Data Points - PASS	74	84	82	85	84	85
% FAIL	12.94	1.18	3.53	0.00	1.18	0.00
% FAIL	2.35		0.59		0.20	

From analysing the % failure, it is recommended that a control limit of  $\pm 2SD$  be implemented for decision making around how to proceed when differences between the Sample SG and Instrument SG result.

**% Solids vs. Sample SG/Instrument SG**

The % solids is determined from the daily sample and is highly dependent on how the sample is retrieved from the sampling point and handled in the Evaluation Laboratory. A Pearson correlation was done between the % solids and Sample SG as well as between the % solids and the Instrument SG for both streams. In both instances, the Pearson correlation co-efficient was slightly better for the Sample than the Instrument. This is due to the % solids being determined from the physical sample itself. In addition, the Pearson correlation co-efficient calculated indicated a poor correlation between % solids and the SG data.

A theoretical calculation was then done to determine what the % solids calculated would be compared to the % solids measured during sample preparation. From theory, the solid ore SG for Plant 1 and Plant 2 is approximately 3.2 and 4.0 respectively. It is assumed here the blending of ore types or treating of waste does not occur.

Parity charts were plotted to compare the % solids measured and the % solids calculated values for Plant 1 and Plant 2 respectively – refer to Figure 9 and 10.

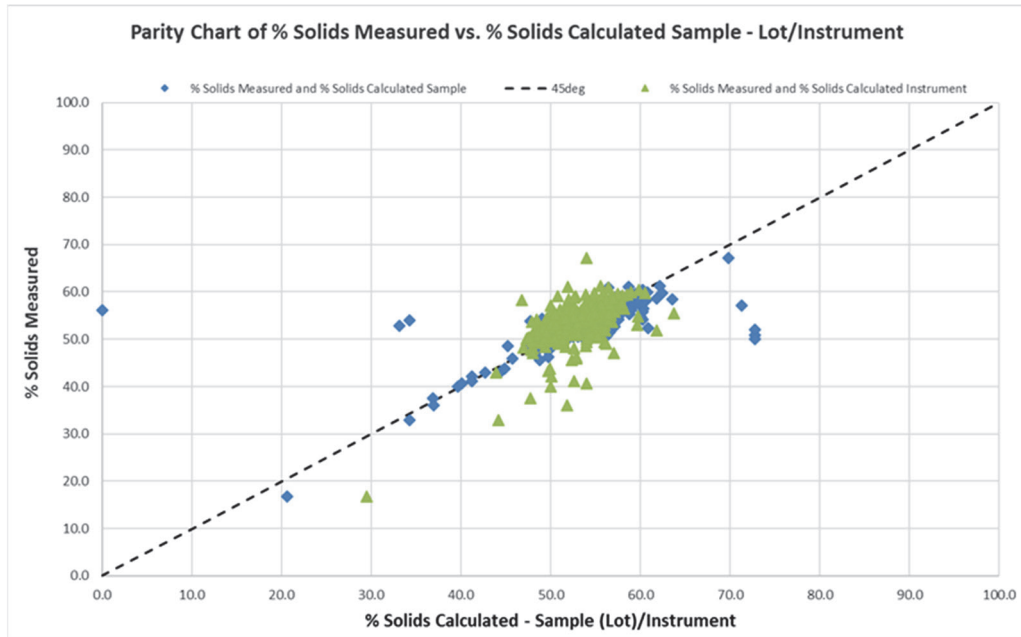

Figure 9. Parity Chart – Plant 1.

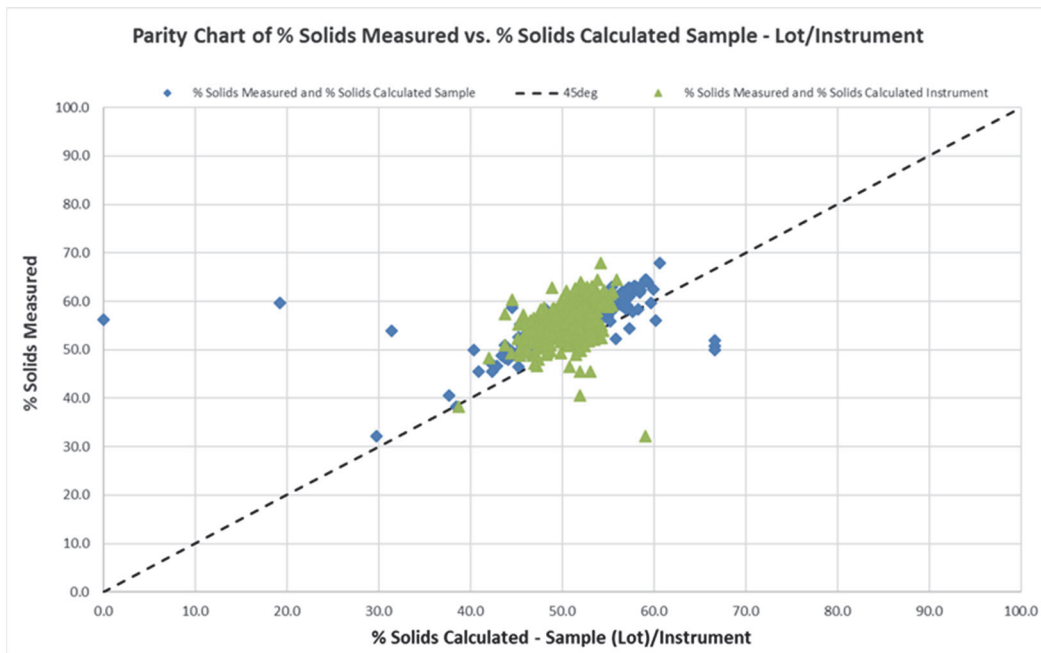

Figure 10. Parity Chart – Plant 2.

As expected, in both cases, the % solids calculated from the Sample SG compares better with the % solids measured as they are inherently related whereas the Instrument SG is not. This tool however can be used to quickly assess if the % solids measured is within range or not.

Through this exercise of analysing the actual data, a quality control methodology was derived. As per previous illustrations, a control limit of  $\pm 1SD$  and  $\pm 2SD$  should be implemented for decision making around how to proceed when differences between the Sample SG and Instrument SG result:

- If the difference is greater or smaller than the 1SD limit of 0.047 for Plant 1 and 0.040 for Plant 2 respectively, then the SG and % solids on the B sample may be done.
- If the difference is greater or smaller than the 2SD limit of 0.094 for Plant 1 and 0.080 for Plant 2 respectively, then the SG and % solids on the B sample must be done.
- If the SG of the B sample compares well with the SG of the A sample but the % solids of the A and B sample differ, then determine the % solids calculated and compare with the % solids measured to get an indication if something went wrong with the sample preparation of sample A, sample B or both samples A and B;
- The control limits must be reviewed every six months with assistance from Group Evaluation Metal Accounting and should be implemented by the Smelter thereafter.

This case study highlights the statement made by Bhattacharya et al.<sup>3</sup>, in that statistical quality control is a promising technique with regards to quality assurance. There is also a need to re-assess upper and lower control limits from time to time and to determine what is an appropriate limit based on the expectations and instrument capability.

### Case Study C: Poor 4T accountability

The importance of sampling in the mining industry cannot be over-emphasized, whether in exploration, in mining or in mineral processing<sup>5</sup>. The conventional wisdom suggests that when the rules and procedures for representative sampling are well defined and followed and the sampling equipment is in good order, unbiased samples will be obtained. In sampling, there are two major areas where bias can exist, namely, sampling and sample preparation. Sampling bias generally occur when (i) increments coincide with cyclic events (ii) when only a portion of the stream is being sampled (iii) where cutter specifications are not being adhered to (iv) when sample containers are overfilled<sup>6</sup>. Therefore, the best defence against any sampling bias is the correct sampling protocol, correct mechanical design of the sampling rig and adequate control and maintenance during its operation<sup>5,10</sup>.

The 4T (individual elemental analysis comprising of elements: Platinum, Palladium, Rhodium and Gold) accountability for all Concentrator Plants within Anglo American Platinum is calculated, charted and is used as a risk management tool to rapidly determine metal content discrepancies between input and output streams. A UG2 Concentrator Plant was historically under-accounting in terms of Platinum Group Metals (Platinum, Palladium, Rhodium and Gold). The current practice at this Concentrator Plant is that crushed run-of-mine UG2 ore is milled in a semi-autogenous (SAG) mill and the mill product is classified using a screen to produce undersize and oversize material streams respectively. The oversize classification screen material is sent back to the SAG mill for further grinding. The undersize material is gravity fed to a surge tank and this material is then pumped to the primary rougher flotation circuit. Prior to being fed to the primary rougher flotation circuit, the material is sampled by an automatic, two-stage, vezin-vezin sampler as seen in Figure 11.

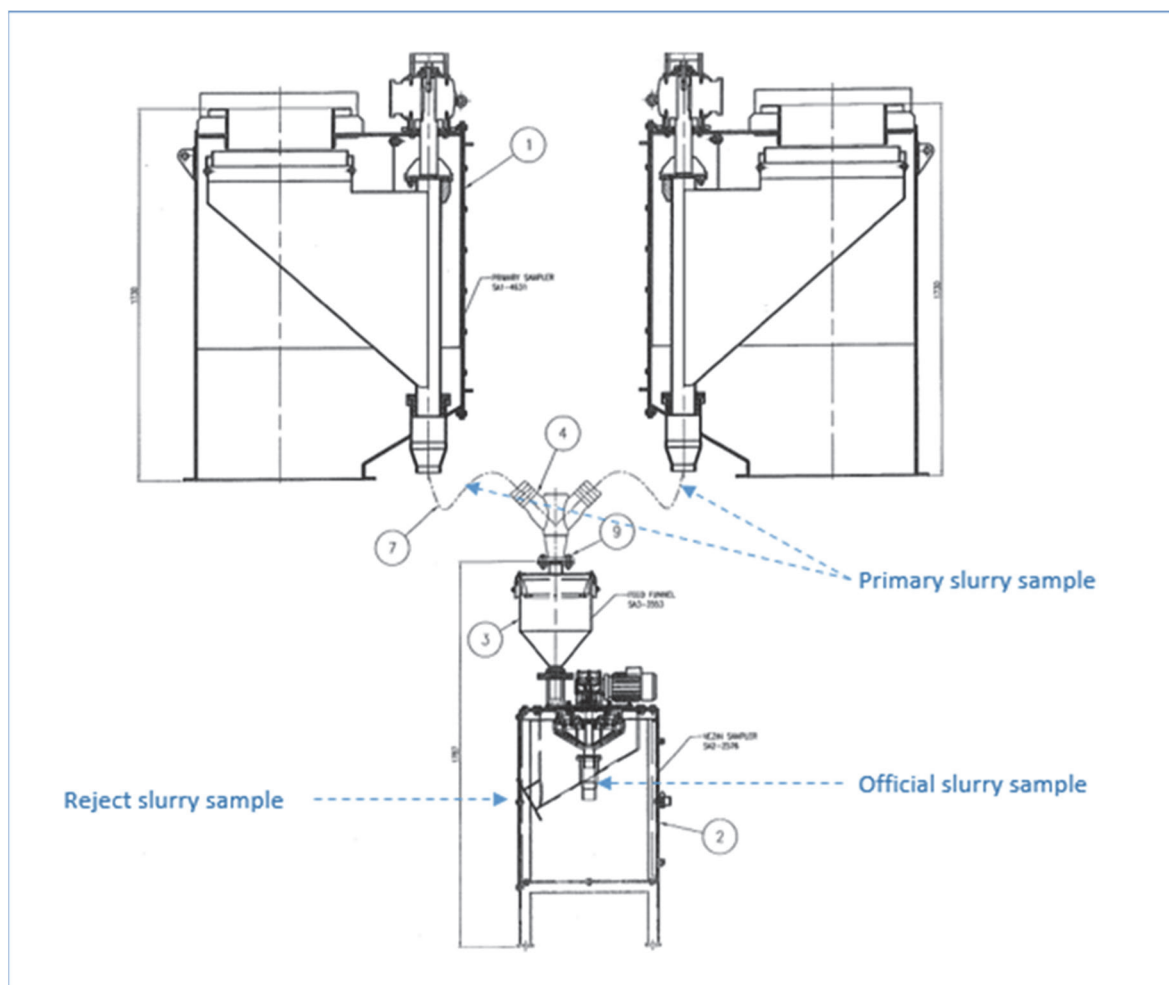

Figure 11. Vezin-Vezin Sampler Combination<sup>8</sup>.

The debate on the source of under-accounting pointed towards possible non-representative sampling or biased sampling occurring in the Concentrator Plant feed sampling system. There were numerous indications that pointed in the direction of the feed sampling system being the problem. Process related challenges such as poor classification screening efficiency and missing classification screen panels led to unnecessary chokes in the feed to the vezin-vezin sampling system. These chokes only heightened the poor accountability trend further. Internal and external audits conducted indicated that all the other parameters contributing to the determination of the accountability value were not to be questioned. There were also no obvious or noted changes in

ore blend ratios and primary mill grind. A sensitivity analysis done using the plant accountability model also indicated that the likely contributor to the poor accountability was the feed grade as opposed to the other parameters. It was hypothesized that the main reason for the consistent under-accounting may be due to over sub-sampling of finer material into the official samples and consequently under sub-sampling of the coarser material present in the feed slurry streams. UG2 feed material size by assay analyses indicate that higher platinum and palladium grades are associated with the sub 75 $\mu\text{m}$  size fractions as opposed to the coarser size fractions above 75 $\mu\text{m}$ <sup>7</sup>. Indications are that because of the under sub-sampling of coarse material, the head grade of the feed into the plant is overstated leading to an under accountability of metal content.

Conventionally, a primary vezin or linear cross stream sampler is used to take a minimum number of primary increments per sampling campaign. For larger increments the flow through the secondary vezin, could be restricted by means of a conical hopper with regulated compressed air at the reduced hopper outlet to agitate the primary slurry increment until sub-sampling is complete. The air agitation alone did not keep all particles, of varying size and density in "equal" suspension throughout the sub-sampling duration of the primary increment. The finer, high-grade particles were suspended for much longer compared to the coarser and heavier, low grade particles resulting in a final sample that was biased low in coarse, low grade particles. This was established through a series of vezin credibility tests. To combat the resulting segregation error, a re-design of the intermediate hopper system was considered, and this included (i) retrofitting the design of the discharge nozzle on the original hopper (ii) use of a new hopper design, that mechanically agitates the slurry with an original discharge nozzle design (iii) use of a new hopper design with the new discharge nozzle design. Replica vezin credibility and chronological sub-sampling tests were done using all the intermediate hopper configurations to measure the evident bias. The results obtained using the original hopper and new nozzle design showed the best improvement in the bias related to particle size distribution in the sub-sample and reject, indicating that particle segregation had been significantly reduced to give more credible sampling results.

From Figure 12 below, a notable improvement in plant accountability was realized with an unbiased relationship between build-up (calculated) and measured feed grade<sup>8</sup>.

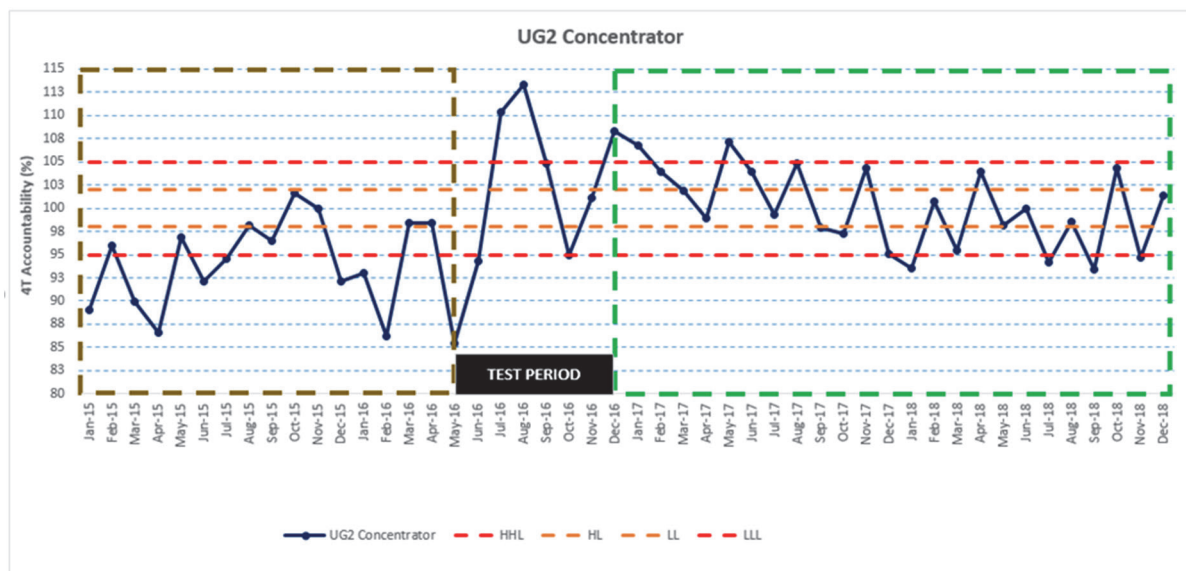

Figure 12. 4T Accountability.

The nozzle re-design, although effective in significantly reducing the bias between the official sub-sample and reject sample, was still limiting in that only a certain number of primary increments could be taken per shift or per sampling campaign. The nozzle re-design did not cater for any process variability. By producing a variogram, the time interval that a sample needs to be taken to overcome process variability can be determined. This comment is further supported by Esbensen<sup>9</sup> statement that "Variographic analysis of the specific lot heterogeneity is demonstrated to furnish a reliable basis upon which to estimate a minimum number of increments needed to suppress total sampling error below a regulatory threshold". The mechanically agitated hopper (MAH) design of 60L capacity together with the nozzle re-design allows for superior benefits including additional flexibility to increase the number of primary increments taken per campaign, agitating and circulating the collected increments and sub-sampling thereafter to produce a more representative sample. This will be applicable in all sampling scenarios but more specifically in scenarios where the process variability in the feed (such as mill grind) is high and increments need to be taken over shorter but regular time intervals. It is envisaged that the MAH will eventually replace all conventional intermediate hoppers in the Platinum division. The initial cost or capital outlay for the mechanically agitated hopper is estimated to be in the region of 200 000 ZAR per sampling point. As an illustration, given that two metal accounting points exist, the risk of a parameter such of recovery being inaccurate by  $\pm 1\%$  over a 12-month period for five years amounts to a Net Present Value (NPV) of  $\pm 244$  million ZAR with a payback period of 2 days. In this case study, mere trending of relevant data was not enough to pinpoint the actual issue and it was highlighted once again that understanding and evaluating ones' material characteristics is indeed not a once off task.

## Case Study D: Poor analytical precision

Crushed dry material sub 3mm is the final product from the Anglo Converter Plant (ACP) and is sent to the BMR for further refining. This material is rich in platinum group metals as well as base metals with Platinum grades ranging between 1000g/t and 2000g/t. The material is sampled via a vezin sampler, and the resulting sample is further processed at the Evaluation Laboratory. Sample splits from the final laboratory purpose splitting method are sent to two internal analytical laboratories and the analytical precision is then determined. The particle size required for assaying this material and any other material in the Platinum Group has historically been 90% (by mass) passing 75 $\mu$ m. This requirement is necessary to have a properly mixed sample that is relatively homogeneous before sampling for fluxing and subsequent analysis. A sample containing precious metals that is not properly mixed for homogeneity will always result in twin stream analysis discrepancies due to the nugget effect.

Over the years, much focus has been placed on evaluating this material stream. The paper by Kruger & van Tonder<sup>10</sup> showcases, in much detail, the process that took place to explain poor accountabilities between the ACP and BMR. An audit and physical inspection as well as a change in the sampling protocol and sampler itself was introduced to eliminate the confirmed sampling bias. Following all these interventions, the accounting between the ACP and BMR had been restored to be within statistical limits with the difference between physical and theoretical stock being below 5% relative to the cumulative input.

For some time, however, the inter-laboratories precision have been outside the relative standard deviation limits of  $\pm 5\%$ , indicating poor precision and thus prompting further investigation. After much test work, it was observed that during the final splitting method of the sample, the presence of platelets following rod milling was the main contributor to the variability in grade between the sample splits sent to the two internal laboratories. It is believed that during rod milling, heat is generated and may cause smearing which in turn creates platelets being higher in grade than the remaining particles within the sample. Kobe & Kruger<sup>11</sup> outlines the details pertaining to the history behind the need for wet rod milling of the crushed dry material prior to assaying. This case study supplements all the observations and comments made in the previous case studies in that assigning a sampling protocol is a continuous process. Even through the material characteristics were well understood and the minimum sample mass was implemented and adhered to, other factors such as sampling and sample preparation errors/non-conformances could easily negate that impact and create further issues downstream. In this case study, the devil was in the detail and looking beyond the quality control was necessary to alleviate the problem. It was essential to re-visit the development of the knowledge base for this material type and emphasize the need to assess materials individually on a chemical and physical basis and assign control limits specific to the material type. The understanding and importance of rod milling was only the beginning and further investigation was needed for overall optimization.

## Conclusion

The case study examples collectively highlights one common question: How does one bridge the gap between having QA/QC systems in place, realizing that there may be an area of concern, and subsequently resolving the concern. For now, the answer remains with continuous, real-time trending of QA/QC data using data analytics in conjunction with equipment inspection and audits. In addition, it ultimately amounts to following basic principles and fully understanding one's material characteristics. QA/QC systems are the key to supplementing further investigation and should be treated as such.

## Acknowledgements

GEMA Team and respective Anglo American Platinum Business Units

## ORCID iDs

Neressa Sukha: <https://orcid.org/0000-0001-5810-9963>

## References

1. AMIRA International Code of Practice: Release 3, 2007. P754: Metal Accounting, February 2007.
2. K. Lomborg, "Best Practice Sampling Methods, Assay Techniques, and Quality Control with Reference to the Platinum Group Elements (PGEs)", in *Sampling and Analysis: Proceedings of the African Mining Conference*. SAIMM Publications, Muldersdrift, South Africa (2013).
3. J. Bhattacharya J, M. Islam, A. Kumar and G. Santosh, "Application of Statistical Quality Control for Limestone Grade: A Case Study", *Institute of Materials, Minerals and Mining*, **116**, 25 – 31 (2007).
4. A. Simon and G. Gosson, "Considerations on Quality Assurance/Quality Control and Sample Security", *Proceedings of the Sampling Conference*, Perth (2008).
5. H. E. Bartlett, "Confidences in Metallurgical Balances Estimated from the Errors in Mass Measurement, Sampling and Analytical Determinations", *Proceedings of the Conference on Exploration, Mine, Met and Environmental Sampling*. SAIMM Publications, Eskom Conference Centre, South Africa (2005).
6. C.J. Kruger and N. C. Millar, Evaluation Manual. Group Evaluation Metal Accounting, Anglo American Platinum, South Africa (2002).



7. S. Ntlhabane, "Benchmark Mineralogical Investigation of UG-2 Concentrator", (Research report, no. MPR/14/183), Anglo Research, Crown Mines Campus Johannesburg, South Africa (2014).
8. N. Naicker and V. Sibanda, "Particle Segregation associated with Sub-Sampling of Flotation Feed at a UG2 Concentrator", **118**, 57-64 (2017). <http://dx.doi.org/10.17159/2411-9717/2018/v118n1a7>
9. K. H. Esbensen, "The Critical Role of Representative Sampling", *Proceedings of the Sampling Conference*, Perth (2012).
10. C.J. Kruger and E. van Tonder, "Pitfalls in Vezin Sampling for Finely Crushed Materials", *The Journal of The Southern African Institute of Mining and Metallurgy*, **114**, 47 – 52 (2014).
11. N. J. Kobe and C. J. Kruger, "Pitfalls of Poor Comminution of Converter Matte during Sample Preparation: One size does not fit all", *Proceedings of the Nineth World Conference on Sampling and Blending*, Beijing (2019).

## Economic benefits of improving precision

---

Trevor Bruce<sup>a</sup> and Michael Hidding<sup>b</sup>

<sup>a</sup>30 Christopher street, Boksburg East, 1459, South Africa, E-mail: Trevor.Bruce@FLSmidth.com

<sup>b</sup>Osborne Park, Perth WA 6916, Australia, E-mail: Michael.Hidding@FLSmidth.com

---

**Better sampling, preparation, and analysis (SPA) can improve the precision of results for resource grades and commodity trading. What we are often asked by customers is how they might quantify these improvements in terms of economic benefits.**

**One way to do this is by applying the SPA precision of your results to the selling price of the resource. In this paper, a deeper look into resource pricing methodology for iron ore will be undertaken and how improved precision, on the quantification of the critical elements in this product, can affect the selling/purchase price of this commodity.**

**Using a real-world example, this paper will show the results of a basic business case study, investigating the return on investment (ROI) for a Sampling Improvement Project (SIP) including a well-designed sampling, sample transport, sampler preparation and analysis facility. The investigation will include the estimated total cost of the SIP, from the problem statement to implementation, together with an estimate on operational costs. This is then compared to the potential profit gains that the SIP could provide.**

**Primary focus will be on structures/methods used to determine commodity prices, how the measurement of the concentration of the critical elements link to pricing, and how variations in measured vs actual concentrations effect the final price. Also considered will be the economic benefits of faster more reliable data collection as well as improved quality moisture measurement.**

### Introduction

There is a lot of consideration within the sampling community around how better sampling, preparation, and analysis (SPA) improves the precision of results for resource grades. The debates, however, often fail to demonstrate how monetizing this improvement can be quantified. Some of these debates and discussions have been highlighted and discussed in the October 2021 edition of Spectroscopy Europe under the special section on Economic Arguments for Representative Sampling<sup>1</sup>.

One way to attempt to quantify this monetary improvement is by applying the SPA precision of your results to the selling price of the resource and then balancing these differences in precision against the costs of improving precision.

The higher the price that resource companies can sell the resource for (with the same cost base) the more profit they can realize. On the same note, the lower the price that consumers (refineries etc.) can purchase the resources for (with the same quality), the more profits they can realize. Two obvious statements but points that tend to be overlooked when delving into the details of motivating for budget to install or upgrade sampling and sample preparation systems.

There is typically a large penalty payable by producers if they overstate the critical element content of their respective resources. It is, therefore, common for producers to understate measured content by the level of confidence or precision they have in their SPA results. The consequence of this is a larger discrepancy in the price they can sell their resource at, compared to what they could be selling it at. The further away from the actual value that the reported value is, the more the producer will lose if the content is understated.

Discussions below will show the results of an investigation into resource pricing methodology for iron ore, and how improved precision, on the quantification of the critical elements, in these products can affect the selling/purchase price.

The investigation will include the review of structures/methods used to determine the commodity price, how the measurement of the concentration of the critical elements drive this pricing and how variations in the concentrations effect the final price. It will also look into a few other economic benefits of a SIP, such as how improved turn-around-time on results, whilst still maintaining confidence in the results, can add to profits earned.

To understand the true ROI it is also important to know what the total cost of the SIP will be, not only the final project, but also the investigations required to establish that a SIP is required, and what systems will be needed to suitably fulfil these requirements. This all requires many man-hours and other resources, all of which have an associated price tag. In addition to this, the final installed system (sampling, sample transport and laboratory) often holds a large price tag that, and if not properly understood and explained to stakeholders, could already put a stop to a project before it has started. Estimations of these costs, based on real world projects, are discussed, and compared to potential gains as well as the cost of lost time whilst the project is underway (i.e., the cost of not having optimal results until the upgraded system is in place). The results of the comparison are used to illustrate what ROI can be expected based on a relatively large automated SIP.

Although this paper is focused on iron ore, the principles of the discussion are universal to all other commodities. Effectively, giving the seller or purchaser the tools to evaluate their product to the highest level of confidence possible will also

enable them to assign the most suitable price tag to the commodity, whilst maintaining or reducing the risk of penalties from over/understating the commodity quality.

### Cost benefits for an Iron Ore port facility

Before we look at the cost savings of a sampling improvement project it will be prudent to investigate the time and cost that is involved in initiating and implementing the project; it is important to establish an understanding of what to expect when approaching this matter. Sampling improvement projects (SIPs) are often shut down before they are started, often because of the perceived high capital cost required for these projects. It is important, therefore, to understand these expected costs from the start and ensure stakeholders are aware of what they should expect to pay for their improved profits that a well-executed SIP will bring them.

The time and costs do not start at order placement on a supplier for the manufacture and integration of a system, but instead they start quite a way back up stream of this. Time, and therefore costs, start already at the investigation stage where it is necessary to establish if there are any improvements possible in a given system. The question could be asked; "why spend time and money investigating a system that is producing as expected and has not shown any signs of concern?" As you will see later in the discussion, the longer an improvement takes to be defined and rectified, the larger the value of the net "un-known" profit loss will be. It is for this reason that regular investigations should be carried out with the intent of continually improving the process.

What will also be highlighted here is the criticality of installing the best possible sampling, preparation and analytical (SPA) system the first time around. This is, primarily, because the cost that will be incurred for the upgrade is far outweighed by the potential profit not realized during the time that it takes to establish the problem, specify a solution, engineer the solution, manufacture, and integrate the solution.

### Scenario requiring a SIP

Although the figures used in the example below are based on actual projects of this nature, the author has chosen to represent these figures as a hypothetical project for the purposes of this paper.

**Scenario:** Here we consider an existing (brown fields) Iron Ore port facility where Iron Ore is blended from stockpiles to achieve a required product grade and transferred via conveyor into a ship hold at a design rate of 5000tph. This facility was initially designed and built with an appropriate SPA system for the nominated throughput, but over time the port increases its loading capacity to 10000tph (50MTPA), whilst failing to upgrade the SPA system accordingly.

What could be wrong with the brownfields sampling system after the plant is upgraded to the higher loading rate?

This is a common problem that, I am sure, most operators have experienced at some point in their careers. Listed below are few possible problems that this facility could face until their sampling, preparation and analytical system is corrected (in no order of importance):

- With increased flow rate, and therefore likely increased belt speed, the primary sample cutter angle could be too shallow for the new flow (i.e., the cutters are no longer cutting through the stream at 90deg)
- With increased burden depth the cutter aperture may no longer accommodate the entire stream
- The flow rate of material could be causing the cutter spoon to fill up too quickly and therefore not all sample is collected in the cutter aperture as it passes through the stream (i.e., material could be steadily overflowing out of the cutter as it passes through the stream)
- It is possible that the drive to move the cutter through the stream is not strong enough for the new rate and therefore battles to move at a constant speed through the material stream
- Precious maintenance and inspection SOPs will no longer be suitable as there will now be a higher wear rate on the cutters, this could be resulting in worn cutters going unnoticed for longer than acceptable
- Because of the higher flow the primary sample will be larger (assuming the cutter was already moving through the stream at 0.6m/s and therefore could not be increased further), the secondary sampler and other downstream equipment (feeders, crushers, and the like) may also be undersized to handle the new sample mass
- With the faster loading rate and the required number of increments remaining the same, the time between primary cuts will be greatly reduced which could result in backlogs in the downstream sampling, sample preparation and analytical systems (leading to possible sample loss, sample mix-ups etc.). This often results in the plant reducing the number of increments which of course could be detrimental to the precision of the sample results due to the increase in sample variance (because of time variation of grade), especially if there is a high level of variability in the ore.
- With larger samples, manually transporting these to the laboratory could now be a concern (further delaying the sample from getting to the laboratory and also furthering the risk of sample degeneration before it reaches the laboratory)

All these problems will result in a number of sampling errors and likely sample preparation and analytical errors as well, if the laboratory is not set up to handle the new load of samples. The financial damage these errors can result in, even if a small error (i.e., resulting in even a 0.1% degradation on precision of results) can be catastrophic. What is even more

alarming, is that these financial losses are almost never even detected - it is difficult to assign a value to a profit most organisations don't even know they are losing out on.

**Analysis of the cost of the large upgrade project**

**Labour costs.** It is often months or years before an alarm is raised that there could be an opportunity to gain additional profits from a SIP. Then from the date that this alarm is raised, as can be seen in the Table 1, it will typically take approximately 3 years to detail and implement an upgraded solution.

As seen in Table 1 and illustrated in Figure 1, between the project owner and their suppliers, approximately 30 000 man-hours are typically spent during this period for engineering (electrical, mechanical, software, etc.), process and sampling specialists, technicians, procurement, management etc. to develop these primary stages:

**Table 1: SIP life-cycle stage duration**

Sampling Improvement Project (SIP) life-cycle stages	Cumulative days	Total man-hours
Identification of problem/opportunity for better sampling	60 days	732.00
Consultation with industry on what is required	60 days	110.00
Testing to quantify what the current situation is and a simulation of what could be possible to quantify what improvement can be made	40 days	1340.00
Define what can be changed to be able to act on better sample information (i.e. what process can be changed/modified in reaction to the sample results to better improve profits)	60 days	410.00
Business case model of what the hidden costs of not improving sampling to analysis are	40 days	350.00
Prepare and issue specification documents for tender	80 days	700.00
Adjudicate tender responses	20 days	310.00
Order placement on successful bidder	20 days	10.00
Detailed design of sampling to analysis system	160 days	16352.00
Manufacturing of systems	100 days	2906.00
Delivery, installation, and commissioning of system	80 days	5160.00
Validation of installed system	40 days	1280.00
Implementation of monitoring and maintenance program for sampling to analysis system	20 days	340.00
<b>Total</b>	<b>780 days</b>	<b>30000.00</b>

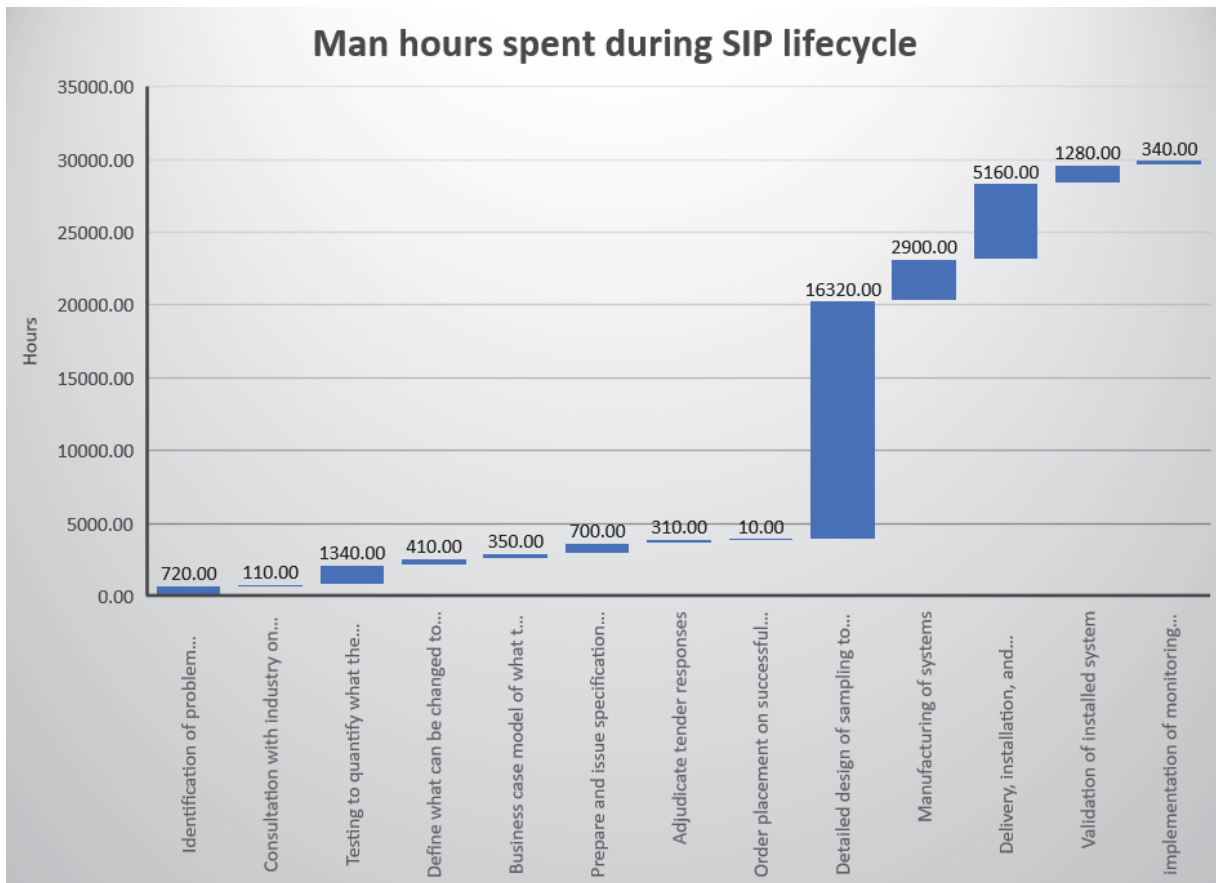

**Figure 1: SIP lifecycle manhours spent**

**Capex and Opex.** Based on past SPA industry solutions of a similar nature, for a +50MTPA iron ore project a suitable (and often the only) solution to be able to sample, transport the sample and analyse the sample fast and precisely enough to allow for confident “real-time” changes to the blending and loading process, is an end to end fully automated sampling to analysis process. As these solutions are typically also the most capital-intensive options, the author has chosen to consider this type of fully automated system for the model. This will represent the highest cost option for comparing any ROI calculations.

Comparing past industry indicative prices, from various leading suppliers in these systems, for a port facility of 10000tph Iron ore (50MTPA capacity), a fully automated sampling, sample transport, sample preparation and analysis system will cost in the region of US\$7.5M. The cost of a new building and services for this facility could add a further US\$2.8M. Then, assuming US\$120/hr as a combined rate for the resources required to carry out the tasks listed above (30000 man-hours), the cost of labour for the project will be US\$3.6M.

The above total estimated project cost is around US\$13.9M from the start of an investigation to the final installed and operational solution. If not already included in the project, any upstream process optimisation changes should also be carefully considered. While this may increase the final project cost, the longer-term benefits will also be greater.

Of course, there are a multitude of configurations that SPA systems could have to reduce initial capital expenditure, e.g. reducing the level of automation, but each concession should be carefully considered, along with the overall purpose of the upgrade, to ensure not to degrade KPI's, such as throughput, cost of sample due to manual handling and precision degradation which are all required to achieve the maximum benefit of the upgrade.

Finally, a cost that must also be considered, is the cost to operate and maintain the facility itself. Although it will be included in the ROI calculations, it should be noted that this cost is not additional, as in the case of this brownfield project example (Scenario requiring a SIP), a SPA system in some form is assumed to be already in place and therefore these operational costs are already being incurred. A conservative estimate for inclusion of operational expenditure (maintenance and spare parts) is approximately US\$1.8M/annum.

### Analysis of economic benefits

Without the context of ROI these numbers may appear to be large, and again, this is where stakeholders struggle to see value, however now we will investigate the economic benefits of implementing best practice SPA. To calculate the ROI for the large capital expense and high operating costs of this application we can consider the primary contributing factors or “money makers/breakers”. The primary factor in this instance, is the potential profit loss due to selling the product below what it could be sold at, as a direct result of the level of sampling, preparation and analytical precision achieved during loading. The precision on chemical analysis will affect the price sold and the precision on the moisture analysis will affect the percentage of on-grade ore that is not billed for (i.e., overstating moisture level will result in less of the loaded mass being invoiced as ore).

In the case of the example noted above, because the upgrade will make it possible to analyse the samples in close to real-time, as the ship is being loaded, it is possible to optimize the grade of material being loaded, by blending the correct grades as it is loaded. This offers the opportunity to increase the total volume of ore available for sale with no other changes in production (i.e., ore that would have been considered low grade waste can now be blended in with higher grade ore and sold at the price of the higher-grade material).

Although smaller in comparison, other benefits of the fully automated system include the ability to process the samples faster and have the laboratory purged and cleaned between batches of material in a much-reduced time. This reduction in process and delay time between lots results in a shorter duration that the vessel needs to be sitting at port, saving on port costs and allows the supplier to issue certified results for invoicing in a shorter period.

**Iron Ore price structure based on precision.** Iron ore products are broken into several different classes/grades of ore. Each grade, however, is still a non-commutable commodity (each unit has unique qualities that add or subtract value) due to its variation in quality. There are many different methods used by large multinational corporations to calculate the purchase price of iron ore at any one time. These methods form the basis of negotiations of larger supply contracts, which can become very complicated. As a basis of discussion in this paper the author has selected one method of pricing, developed by an international price reporting agency (PRA); Metal Bulletin (Fastmarkets MB). This method involves an index of key price-affecting chemical components of Iron Ore, namely: iron, silica, alumina, and phosphorus. The indices are called the Value-In-Use (VIU) indices.

To better understand this method, and how it is applied to prove points noted above, it is good to have a slightly better understanding of the iron ore market. Below is a summary of this based on information referenced from an article in the MetalMarket Magazine, June 2018<sup>2</sup>

**The article notes the following:**

Different percentages of iron content reflect both the natural variation in iron ore grades found in mine deposits and the degree of processing (if any) employed to upgrade the ore for a certain use. In general, higher purity ores help increase hot metal yields in the blast furnace, and lower production cost by reducing the amount of coke required. For these reasons, the rule of thumb is “higher Fe grade, higher price.”

Market conditions drive the preferences for the various ore types, and the differentials between the different iron ore indices are dynamic. Profit margin, defined by the price of the final product less the cost of raw materials, that steelmakers are achieving, is considered to be one of the largest drivers of these market conditions.

Because Blast furnaces cannot easily be switched on and off, to optimize their operating rates in varying market conditions, steelmakers need to be astute in purchasing of iron ore.

To maximize blast furnace yields, when margins are high, steelmakers prefer high-purity ores to optimize the profits from each tonne they produce, however, Low-grade ores are turned to by steelmakers when margins fall away, to minimize their production rates and reduce costs.

More recently, at least in China, environmental policy has become a key driver of prices across the iron-ore grade spectrum. Typically, lower-grade ores with higher fractions of deleterious elements such as silica and alumina require increased consumption of coke, which can raise emissions of controlled gases and particulates.

Also quoted directly from this article:

*“Though Metal Bulletin published indices for several grades of iron ore, the real-life variability is such that virtually all ores differ in some respect to the base specification of the index they settle against. Where actual iron ore grades do not match the index specifications exactly, counterparties typically agree premiums or discounts based either on bilateral negotiation or using the VIU indices published by PRAs. Metal Bulletin’s VIU indices, calculated and published monthly, help companies agree upon appropriate price adjustments based on the iron, silica, alumina and phosphorus content of their specific products.”<sup>2</sup>*

**Price calculation using VI.** With the Value-in-use indices, each of the key elements are considered separately and compared to the base value of the specific grade of iron ore. Although each element is looked at in isolation their VIU adjustment<sup>3</sup> is applied additively for the difference in each chemical content from the index base specifications. Considering a 62% Fe fines ore, the price formula is as follows:

**Price=index+[(actual Fe - 62)×Fe\_VIU]+[(actual Si - 4)×Si\_VIU]+[(actual Al - 2.3)×Al\_VIU]+[(actual P - 0.1)×P\_VIU×100]**

**Precision (2σ) on chemical results of critical elements.** For the purposes of discussion, it is noted that the actual accurate value of ore being loaded is perfectly as per the base values for this commodity type, i.e., Fe=62%, Si = 4%, Al = 2.3% and P = 0.1% with moisture of 8%. It is then considered that, to avoid harsh penalties for overstating the quality of the ore, the supplier will degrade/understate their analytical results based on the SPA precision achieved (i.e., with a 0.35% precision on Fe, the supplier will degrade the product value by 0.109% when calculating the final price of the product as-loaded).

Although some automated port laboratories in South Africa and Australia have managed to reduce their total precision for Fe to just below 0.16%, as a baseline in this calculation the author has chosen to consider the overall precision specified in table 1 of the ISO 3082 specification for Iron ore<sup>4</sup> (+210kt lot as per figure 2), as the value that the upgraded sampling to analysis project should aim for. These levels of precision will be applied to the critical elements and considered scenario 1 (results after upgraded SPA system)

Table 1 — Overall precision,  $\beta_{SPM}$  (values as absolute percentages)

Quality characteristics		Approximate overall precision								
		$\beta_{SPM}$								
		Mass of lot t								
		Over 270 000	210 000 to 270 000	150 000 to 210 000	100 000 to 150 000	70 000 to 100 000	45 000 to 70 000	30 000 to 45 000	15 000 to 30 000	Less than 15 000
Iron content		0,34	0,35	0,37	0,38	0,40	0,42	0,45	0,49	0,55
Silica content		0,34	0,35	0,37	0,38	0,40	0,42	0,45	0,49	0,55
Alumina content		0,11	0,12	0,12	0,13	0,14	0,15	0,16	0,18	0,20
Phosphorus content		0,003 4	0,003 5	0,003 6	0,003 7	0,003 8	0,004 0	0,004 2	0,004 5	0,004 8
Moisture content		0,34	0,35	0,37	0,38	0,40	0,42	0,45	0,49	0,55
Size – 200 mm ore	– 10 mm fraction mean 20 %	3,4	3,5	3,6	3,7	3,9	4,0	4,2	4,4	5,0
Size – 50 mm ore										
Size – 31,5 + 6,3 mm ore	– 6,3 mm fraction mean 10 %	1,7	1,75	1,8	1,85	1,95	2,0	2,1	2,2	2,5
Size – Sinter feed	+ 6,3 mm fraction mean 10 %									
Size – Pellet feed	– 45 $\mu$ m fraction mean 70 %									
Size – Pellets	– 6,3 mm fraction mean 5 %	0,68	0,70	0,72	0,74	0,78	0,80	0,84	0,88	1,00

NOTE The values of  $\beta_{SPM}$  for silica, alumina and phosphorus content are indicative and subject to confirmation through international testwork.

NOTE The overall precision for other physical characteristics and metallurgical properties is not specified in this International Standard, because they are used to qualitatively compare the behaviour of iron ores during handling and reduction processes.

Figure 2: Table 1 from the ISO 3082<sup>4</sup>

Of course, it must be noted that no amount of downstream treatment can resolve large sampling error noted in the sampling problems above, and that in this example (Scenario requiring a SIP), trying to quantify the accuracy and precision of the samples taken, compared to the actual grade of the lot is nonsensical and not possible. But, again for the purpose of the discussion it is conservatively assumed that even with all the problems of the system noted in the example (Scenario requiring a SIP), before the SIP upgrade, the precision achieved for this grade of product is as follows: Fe precision = 1%, Si precision = 1%, Al precision = 2% and P precision = 0.35% with moisture of 15.35%. In manually operated sampling and sample preparation labs it is not uncommon to see precision values well in excess of 5% for Fe, so it should be noted that the estimate here is conservative. These levels of precision will be applied to the critical elements and considered scenario 2 (results before upgraded SPA system).

If the index price of 62% Fe fines is as per the values taken from the MBIOI (Fastmarkets MB Iron Ore Indices) index from the 8<sup>th</sup> September 2021 (code MBIOI-62), the selling price of scenario 1 and 2 can be calculated:

- 62% Fe fines = \$132.19
- Fe-VIU = 2.55
- Si-VIU = -4.97
- Al-VIU = -5.99
- P-VIU = -0.7

Scenario 1 (results after upgraded SPA system):

$$\text{Price} = \$132.19 + (61.892 - 62) \times 2.55 + (4.007 - 4) \times -4.97 + (2.301 - 2.3) \times -5.99 + (0.1 - 0.1) \times -0.7 \times 100 = \$131.87$$

Scenario 2 (results before upgraded SPA system):

$$\text{Price} = \$132.19 + (61.69 - 62) \times 2.55 + (4.02 - 4) \times -4.97 + (2.323 - 2.3) \times -5.99 + (0.100185 - 0.1) \times -0.7 \times 100 = \$131.15$$

From this example, it is seen that if no upgrade project is carried out the supplier could be losing at least US\$0.72/tonne of ore that is sold. If this facility is selling 50MTPA this would be worth up to US\$36 000 000/annum in lost profits.

The charts below (Figure 3 and Figure 4) illustrate the resultant profit degradation as the total precision deteriorates.

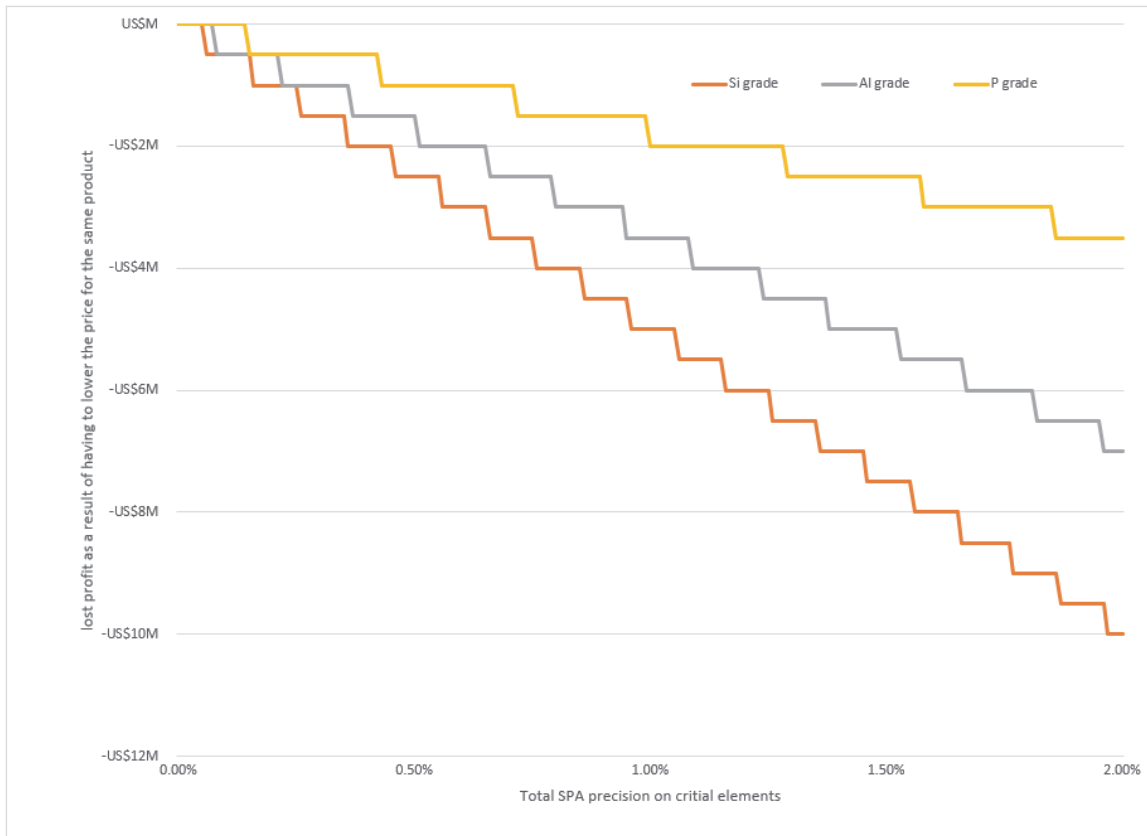

**Figure 3: Profit degradation with deterioration of precision on deleterious elements for a 50MTPA iron ore port facility**

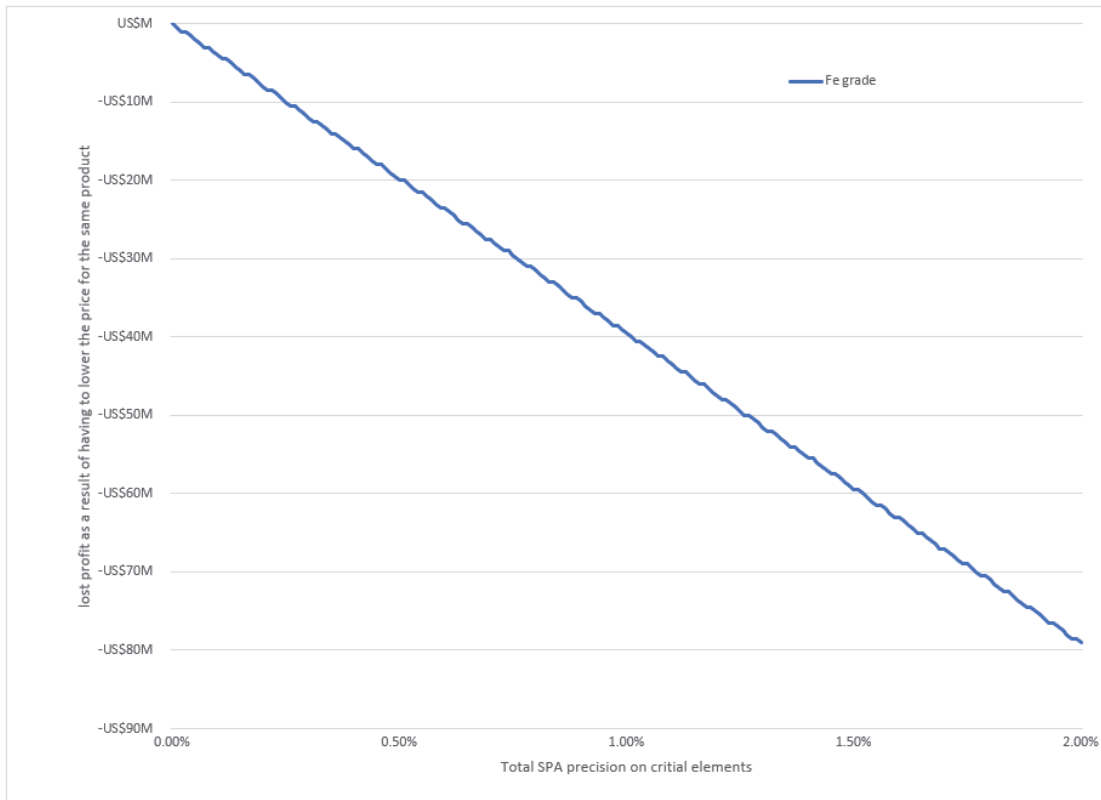
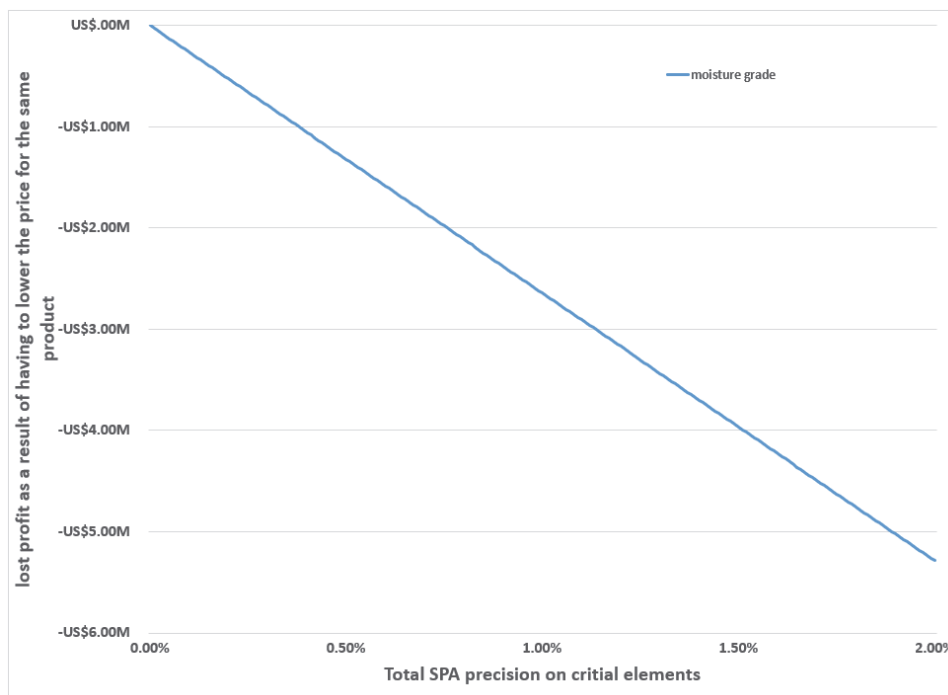

**Figure 4: Profit degradation with deterioration of precision on Fe for a 50MTPA iron ore port facility**



**Precision on Moisture.** If we then consider the effect precision of the moisture value has on the effective price (using the index price of 62% Fe fines with a moisture base of 8% as per the values taken from the MBIOT Fastmarkets MB Iron Ore Indices<sup>3</sup>) then scenario 1 (0.35% total precision, 2  $\sigma$ , on moisture) would be charging for 0.014% less product than actual ( $0.0035/2 \times 8$ ), and scenario 2 (15.35% total precision, 2  $\sigma$ , on moisture) would be charging for 0.614% less product than actual ( $0.1535/2 \times 8$ ). So, by upgrading the facility (assuming the upgraded facility could achieve a 0.35% precision on the stated moisture), the supplier will be able to sell 0.6% more ore with no other process change requirements. This equates to 300 000 tonnes of ore on a 50MTPA facility or US\$39 657 000/annum additional profits at the iron ore price noted above for the 62% Fe fines.

The chart below (figure 5) illustrates the resultant profit degradation as the total precision on moisture deteriorates.



**Figure 5: Profit degradation with deterioration of precision on Moisture for a 50MTPA iron ore port facility**

**Faster turn-around time.** It is even possible for a producer to realise savings that they did not expect to achieve with a SIP. An example of this is experienced by an Iron ore port facility that realized that by being able to invoice their client over two days earlier for every shipment resulted in them getting their “money in the bank” faster and benefiting from the interest earned for these additional days. Assuming an interest rate of 5%pa on invoiced costs, a Fe price of \$132.19/DMTU and a lot size of 200kt, this was worth around US\$7243/200000t vessel loaded, the overall yearly value, of which, equated to over US\$1 810 821.92/annum additional profit.

**Opportunity to carry out “in-ship” blending of ore.** As noted earlier, if the port facility has the required infrastructure to react quickly enough to change using the near real time data, with the level of confidence needed in the data, low grade ore can be blended in with higher grade ore as the vessel is being loaded. This optimizes the use of both high- and low-grade ore reserves. For a 50MTPA port facility this could mean selling at least 0.1% additional ore that would have previously been assigned as waste product. At the above price of US\$132.19/t of 62% Fe fines (as above) this would equate to an additional US\$6 609 500/annum additional profit previously not possible.

### ROI for a large SIP – 50MTPA Iron Ore port sampling to analysis facility

The above scenarios provide a good understanding of what can be expected in regard to the cost of implementing a SIP as well as what the possible economic benefits are. The larger scale of the operation, the more there is to win or lose. Let’s now consider the comparison between expected CAPEX and possible profits achievable after the sampling improvement project has been completed.

From the sections above (summarized in table 2), the estimated CAPEX for the world class SIP considered is US\$13 900 000 with an ongoing operational cost of around US\$1 800 000. In comparison, the potential profits to be realized because of this SIP are as follows and as per figure 6 below:

- Profits from enabling a higher price to be charged for the same ore, US\$36 000 000
- Profits from being able to charge for more ore (less water) for the same product, US\$39 657 000
- Potential additional profits resulting from the ability to process the samples faster, US\$8 420 321

Offsetting these gains to the capital and operation costs a Pay-back period of less than 3 months is possible as can be seen in figure 7.

**Table 2: Breakdown of ROI input values**

Item description	Expense (labour and CAPEX)	Operational costs/year	Potential profit gains after SIP (/year)
Cost of man hours from owner and supplier	US\$ 3.60M		
Automated sampling, transport and laboratory	US\$ 7.50M		
Building and services	US\$ 2.80M		
Total capital cost	US\$ 13.90M		
OPEX/year		US\$ 1.80M	
Value of faster loading rate (invoice 2 days earlier)			US\$ 1.81M
Ability to charge more due to improved precision			US\$ 36.00M
Ability to optimize grade by blending in ship (improvement of 0.1% additional on grade ore)			US\$ 6.61M
Moisture result precision (Improvement from 15.35% to 0.35%)			US\$ .40M

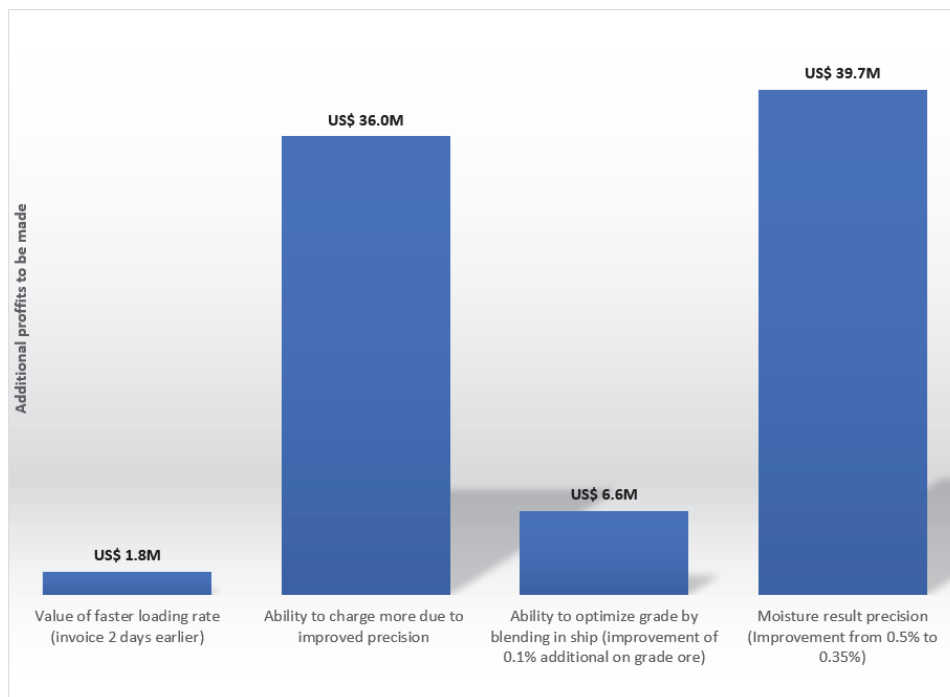

**Figure 6: Potential profits that can be realized after a SIP**

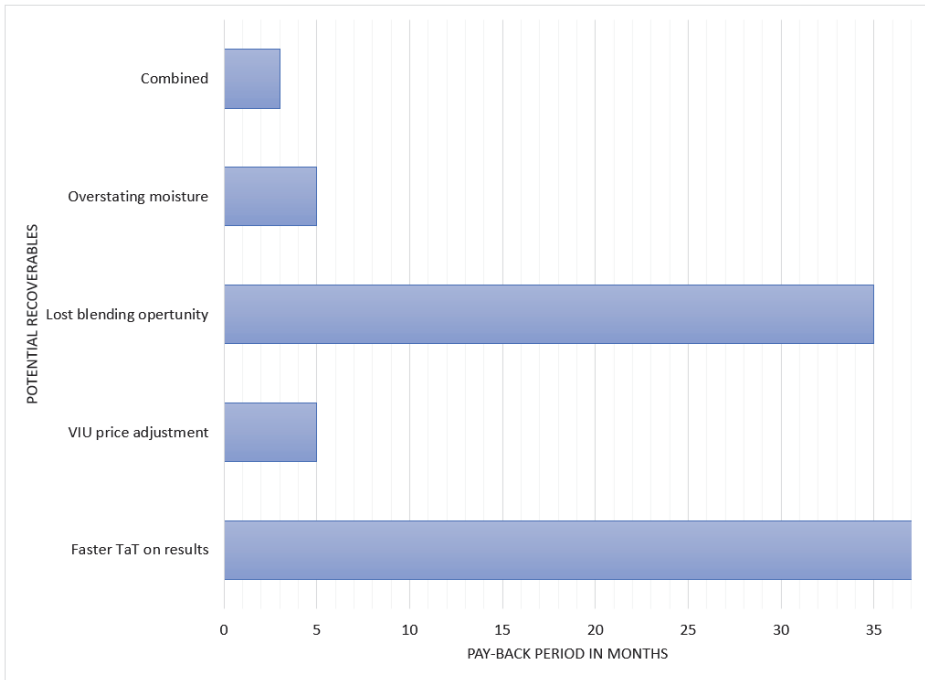

Figure 7: Possible ROI

**Consider on 20% of possible profits.** It could be argued that these are only a best case potential profits, so this ROI could be unreasonable. But even if it is considered that only 20% of these additional earnings are possible, as per the chart below (Figure 8), a combined pay-back period of less than 11 months is still possible.

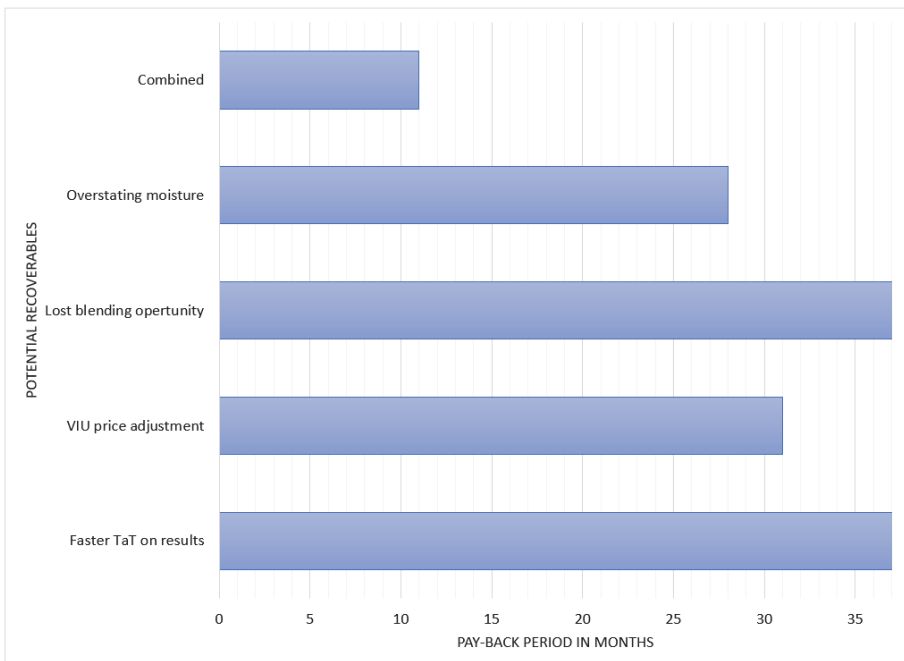

Figure 8: Pay-back period based on 20% of the potential gains

### Cost of installing an under designed or unfit for purpose sampling to analysis system

As per table 1 above, it can take well over 3 years to take a sampling improvement project from the problem statement to implementation, especially for a brownfields (existing) facility. Based on the figures above the potential profits not realized in those 3 years could amount to anywhere between US\$55 000 000 to US\$250 000 000. If the full system, from sampling to analysis, had been better considered at the start of the complete port facility (i.e. when the facility was first installed), and all future upgrades could have been included in these early designs, it could have been possible to bank these additional profits.

## Discussion

Pricing methodologies and contractual agreements for Iron Ore and other commodities can come in many forms and are often very complicated. What remains constant, however, is that if the analysis of the grade or product is not accurate and precise the calculated price for this material will be incorrect. In the above example this has been proven using the difference in price between what a poor sampling, sample preparation and analysis system can provide, compared to a well-designed complete end-to-end solution. If, in this case, the supplier/purchaser contract pricing method used was different and perhaps could have been a more traditional contract, with a fixed price for a set grade of ore, then potential profit could still be calculated based on the precision of the results. That is to say, it could be assumed that the supplier sets the grade of the product higher based on the level of precision and confidence that they have in the results. This has a direct impact on the amount of ore that can be sold as “on-grade” and how much “good” ore is lost because it is considered waste when it could have been sold as high grade.

This concept does not only apply to final load out product and could be considered throughout the process chain, from exploration through to final refined product. If each step in the production process can be monitored with a high level of precision, especially if it possible to get these results in real time, this can reduce costs by allow for better control of use of additives, recognise trends resulting in maintenance predictions, finely adjust process parameters in accordance with the results to optimize the overall process, etc. all of which result in better profits.

As seen in the example above (in the section labelled; Scenario requiring a SIP), it is highly critical to consider possible future expansions of the plant when designing the sampling system. If this is not done then either the SPA system will throttle the ability of the plant to produce more or (as in this same example) the plant is expanded without upgrading the sampling system which also has massive “unseen” costs to the facility (a possible US\$250 000 000, excluding the time that this problem went un-noticed). It should also be noted that, before a budget is assigned to a sampling improvement project (SIP), by various stakeholders, it is key for these stakeholders to ensure that a suitable business case study is carried out to understand what the potential cost of a “cheaper” system could be on the long-term profitability of the plant. Specifications and KPI's for the SIP should be based on this study and every compromise to the specified “ideal” system should be well considered against these KPI's, i.e., if the system is downgraded from the “ideal” how will this affect the KPI's and will this system still achieve what is expected from it.

Management and executive members often only see sampling and laboratories systems as something to have in place only to satisfy contractual requirements for sale of the product, and therefore assign little thought (and budget) to them. By looking at historic data, looking at where better quality results could have been used to realize additional profits, consider how these better results can be achieved through sampling improvement projects and presenting this in a financial model or business case, there may just be a shift in how these systems are perceived throughout the organization.

## Conclusion

It is possible to define the economic benefits of being able to improve precision of results through sampling improvement projects (SIPs). This can be done by comparing the price of product if the precision is high and if it is low. In the real-world example discussed in this paper, a pay-back period of less than 11 months is calculated on a US\$13.9M SIP investment (this is considering only 20% of the possible gains are realized). In basic terms, on a 50MTPA operation the revenue received is US\$6.6B/annum (based on the Fe price in the example above), the total potential additional earnings, while only 2.4% of this, can add up to over US\$84M/annum.

It is also concluded that all systems should be continually monitored and investigations into improvements should be carried out a regular basis. This is critical to ensure that the least possible time is spent operating a system that is not making as much profit as it could be.

## References

1. Multiple authors, 2021. Spectroscopy Europe, October Edition, p:11-79
2. P. Hannah and J Mulcahy, 2018. Iron ore pricing explained, in MetalMarket Magazine, June Edition, p:44-45
3. Fastmarkets MB, Iron ore indices, Methodology and price specifications – January 2022
4. ISO 3082:2017, Iron ore – Sampling and sample preparation procedures



## Implementing proactive Quality Assurance Quality Control (QAQC) and Quality Management (QM) practices at Coal Testing Laboratories

J. Kelly<sup>a</sup> and O. Dominguez<sup>b</sup>

<sup>a</sup>Geometallurgist, BHP Mitsubishi Alliance (BMA), 480 Queen Street, Brisbane, QLD, 4000. E-mail: john.j.kelly@bhp.com

<sup>b</sup>Global Principal QAQC, BHP Geoscience Centre of Excellence, L33, 125 St Georges Tce, Perth, WA, 6000.

E-mail: oscar.r.dominguez@bhp.com

**Many commercial coal testing laboratories are accredited to ISO 17025<sup>1</sup> – General requirements for the competence of testing and calibration laboratories. There is an expected reliance in the Coal mining industry that the laboratory adheres to all elements of this standard in between successive accreditation audits conducted every 18 months by the independent accreditation body, National Association of Testing Authorities (NATA).**

**In the absence of proactive QAQC & QM practices monitoring the quality of the information reported by laboratories, potential issues impacting production decisions and reconciliation results are only determined in a reactive manner.**

**In addition, for mining companies working with several internal and external laboratories across the supply chain, the management of the logistics, practices and information becomes very challenging and time-consuming, impacting the company's ability to track laboratory results as key inputs in a production and reconciliation perspective.**

**The absence of proactive QAQC & QM practices results in a sub-optimal/reactive approach in the Coal industry, increasing the risk of short-term unaware production gaps related to quality, increased time required for quality breach investigations, the absence of a holistic approach/monitoring in the value chain, and the financial impact for the business performing under sub-optimal conditions.**

**This paper aims to show the journey towards the implementation of a new proactive QAQC and QM program, where now the quality of many different laboratories across the supply chain can be monitored and linked with global reconciliation results, as an improvement opportunity to complement the current industry standard ISO 17025 accreditation and Proficiency Round Robin approach.**

### Introduction

The current benchmark, as a QAQC program in the Coal mining industry, is the alignment of laboratory practices to ISO requirements. The vast majority of commercial (and some non-commercial) coal testing laboratories in Australia are accredited to ISO 17025:2011. There is an expected reliance in the Coal mining industry that these laboratories adhere to all the elements of this standard in-between successive accreditation audits conducted by the independent accreditation body, National Association of Testing Authorities (NATA). NATA's standard audit frequency is 18 months and therefore, in the absence of a proactive QAQC & QM practice monitoring the quality of the information reported by laboratories for customers, potential issues impacting production decisions and reconciliation results can only ever be determined in a reactive manner and information's quality only rely on laboratory's internal QAQC. In other words, a number of issues could arise 'unchecked' for laboratory's customers during the 18 months in-between these independent laboratory technical reassessment audits, issues that can potentially impact on the quality (precision/accuracy) of the results being reported by the laboratory to their customers resulting in unplanned out of specification product and the like. A robust proactive approach to QAQC and QM would identify these types of accuracy and precision issues before they become an issue.

### Current reactive QAQC and QM coal industry practice

Reactive by its very definition is always after the fact, investigations into quality breaches are conducted after the train leaves the mine for the port or after the ship has loaded and set sail. Quality breach investigations take time to perform and tie up valuable resources in response to a situation rather than controlling it. Reactive QAQC and QM practices are backward looking and provide limited opportunities to introduce opportunities for continuous improvement.

Typically, reactive QAQC & QM programs are ad hoc in nature, for example: in response to a quality breach a Round Robin program might be organised to test the laboratory against another one, or many in an attempt to identify a bias or trend.

In a reactive QAQC environment, elements that affect sample analysis such as laboratory calibrations, compliance to national or international standard methodologies and the results of the laboratory's internal QC program might only be reviewed by the customer following a quality breach. This is because of industry expectations of the ISO17025 accreditation process creating a false

sense of confidence and reliance on compliance is a driver of this reactive environment.

A reactive approach to QAQC & QM may involve the following elements:

- External Coal proficiency Round Robin program to monitor technical competence of testing laboratories.
- On-site technical audit to review a laboratory's operation to ensure methods, equipment, personnel, QC, calibration, result validation and reporting are fit for purpose.

This approach only provides information of a snap shot in time and does not really go far enough to identify emerging trends or the presence of true bias.

## Proactive QAQC and QM

The requirements of proactive approach to QAQC and QM involve the following key components (Dominguez, 2019<sup>2</sup>):

- Quality Assurance (QA), refers to the plan in terms of controls, tools and practices that need to be implemented to assure the quality of all data or deliverables ("where, what and when to apply"). On Sample Analysis, the basic controls should target:
  - Laboratory calibrations that shall be performed for major and minor elements, because of the impact on the assays reported.
  - Laboratory internal QAQC process to review assay results by batch before results are reported.
  - On-site technical laboratory audits to ensure the previous two points are being performed as per prescribed cadences.
- Quality Control (QC), refers to the thresholds used to assess (approve or reject) QA performance".
  - Round Robin proficiency programs to monitor technical competence of testing laboratories.
  - Coal Reference Materials (Coal RMs) to monitor laboratory accuracy and precision at low-mid-high grade ranges/saturations.
- Quality Management (QM), refers to:
  - Continuous monitoring stage to proactively determine control performance deviations.
  - The precursor of appropriate corrective actions to close gaps (escalation), especially trend analysis (by ranges time and/or grades).
  - Recognise the good work.
  - Final verification step to check the gap has been closed.

## Implementation of a more proactive approach

In order to implement a more proactive approach, the following elements are suggested for the coal industry, to complement those discussed in the reactive approach:

- Arrange for regular on-site technical audits to be conducted in-between the 18 month NATA ISO17025 accreditation audits. These technical audits must review the laboratory's operation to ensure methods, equipment, personnel, result validation and reporting remain fit for purpose in-between accreditation audits. In these audits also ensure that the prescribed cadence for calibration and internal QC activities are maintained. **Figure 1**, shows an example of a laboratory calibration schedule.

CALIBRATIONS 2022		Due	Overdue	In progress	Complete									
LAB/PTL	Task:	Frequency:	January	February	March	April	May	June	July	August	September	October	November	December
EXTERNAL	Balance Masses - NATA Source (external) Larger masses	Yearly												
EXTERNAL	Balance Masses - NATA Source (external) smaller masses	3 Yearly												
LAB/PTL	Balances Analytical - One Point Check	Monthly	24/01/2022											
EXTERNAL	Balances Analytical - Repeatability (external) - ensure to compare against 3 yearly calibration report	6 monthly (mixed over the year) various												
EXTERNAL	Balances Analytical Calibration - NATA Certificate Issued	3 yearly - Due 05/2022												
EXTERNAL	Analytical & 300kg - Service by NATA Reg. Authority	6 monthly												
LAB	Relative Density Bottles	3 monthly if in use												
LAB	Crucible Swell Apparatus - Temperature Check	Monthly												
LAB	Volatile Crucible Register	Yearly												
LAB	Combustion Furnaces - Temp. Ck	Yearly												
LAB	Ash Fusion Furnace - Temp. Ck	3 monthly if in use	25/01/2022											
LAB	CHN Truspec Furnace - Temp. Ck	Yearly												
LAB/PTL	Gray King Furnace - Temp. Ck - upon use	Yearly												
LAB	CHN/Sulphur Furnace - Temp. Ck	Yearly												
LAB	SE32 Sulphur Furnace - Temp. Ck	Yearly												
LAB	Volatile Furnace - Temp. Ck	6 monthly												
LAB	ASTM Volatile Furnace - Temp. Ck	6 monthly												

Figure 1. Example laboratory calibration schedule.

- Arrange coal proficiency Round Robin programs to monitor the technical competence of testing laboratories across the coal quality supply chain. This approach allows the companies to review all of its laboratories across the supply chain (>20 laboratories). Robust Z-score statistics are reported for each analysis parameter reported by each laboratory in each program, Z-scores greater than ±3 are identified as outliers.

In the past, data management was difficult and time consuming, and all the setup for the visualisation process used to take days to be compiled. Currently, formats can be developed in Spotfire and the visualisation process (in different types of graphs) now takes few seconds. For example, visualisation of the Z-scores in Box Whisker format for each parameter allows for trending and comparative analysis to be performed. Figure 2, shows a Box Whisker plot of Z-scores for individual laboratories across 5 different organisations for ash. This visualisation enables the direct comparison of 26 laboratories in the one view making it easier to identify potential intra and inter laboratory trends and biases, and also, has application in supporting the Reconciliation process across the coal quality supply chain.

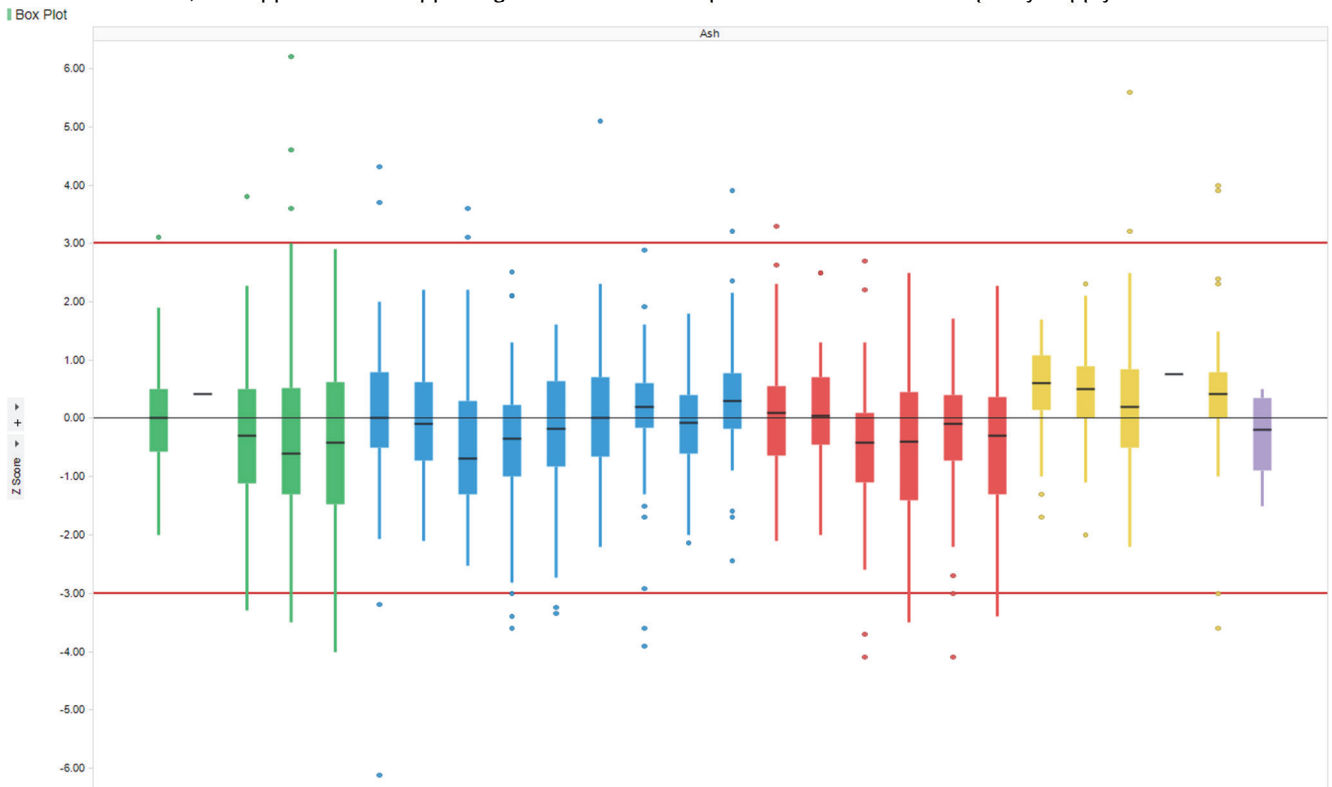
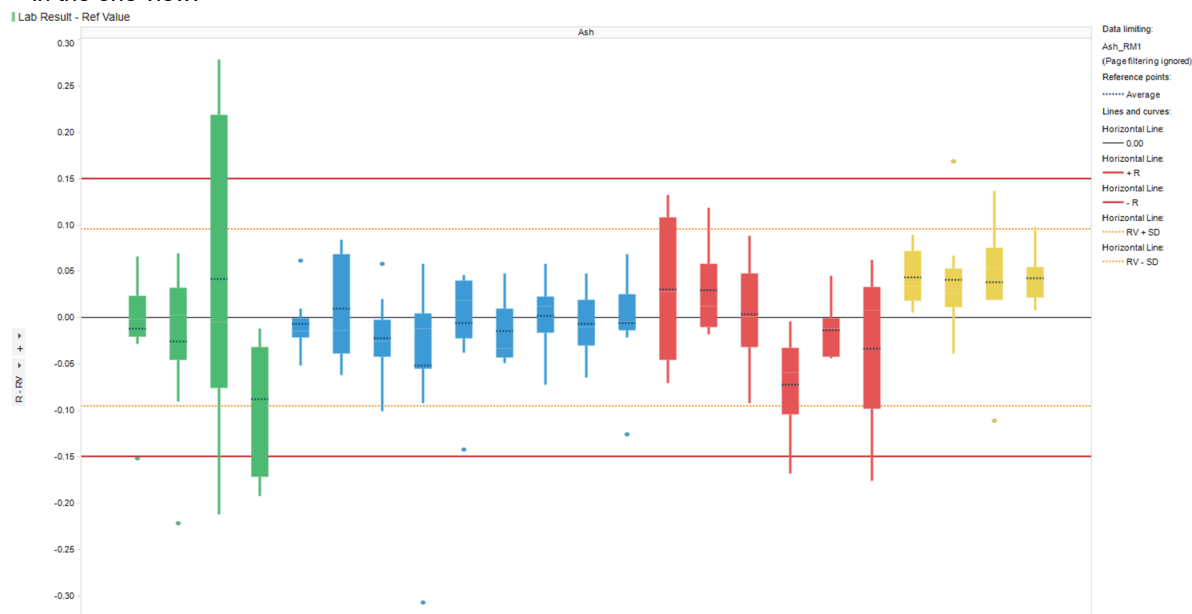

Figure 2. Box Whisker plot of Z-scores for individual laboratories across 5 different organisations for ash.



- On a sampling perspective, in previous years, samples used in the Round Robin used to be prepared and analysed, meaning different sources of error impacting the final results, for this reason coal pulverised and homogenised Reference Material (RMs) is now used as blind samples, allowing the company to review the precision and accuracy of analytical results all of its laboratories across the supply chain. For each coal RM the difference between each laboratory's result and the reference value (delta) is monitored for each parameter against the method reproducibility (R) limit for that parameter, deltas greater than  $\pm R$  are identified as outliers. **Figure 3**, shows a Box Whisker plot of the differences between laboratory results and the coal RM reference parameter value for individual laboratories across 4 different organisations for Ash. This visualisation enables the direct comparison of the precision and accuracy of 23 laboratories in the one view.



**Figure 3. Box Whisker plot of the differences between laboratory results and the coal RM reference parameter value for individual laboratories across 4 different organisations for Ash.**

**Figure 4**, shows the standard score 3 month moving average plot. The standard score is the number of standard deviations by which the laboratory result is above or below the reference value of the Coal RM. This visualisation enables the direct comparison of emerging trends or bias of 23 laboratories in the one view.

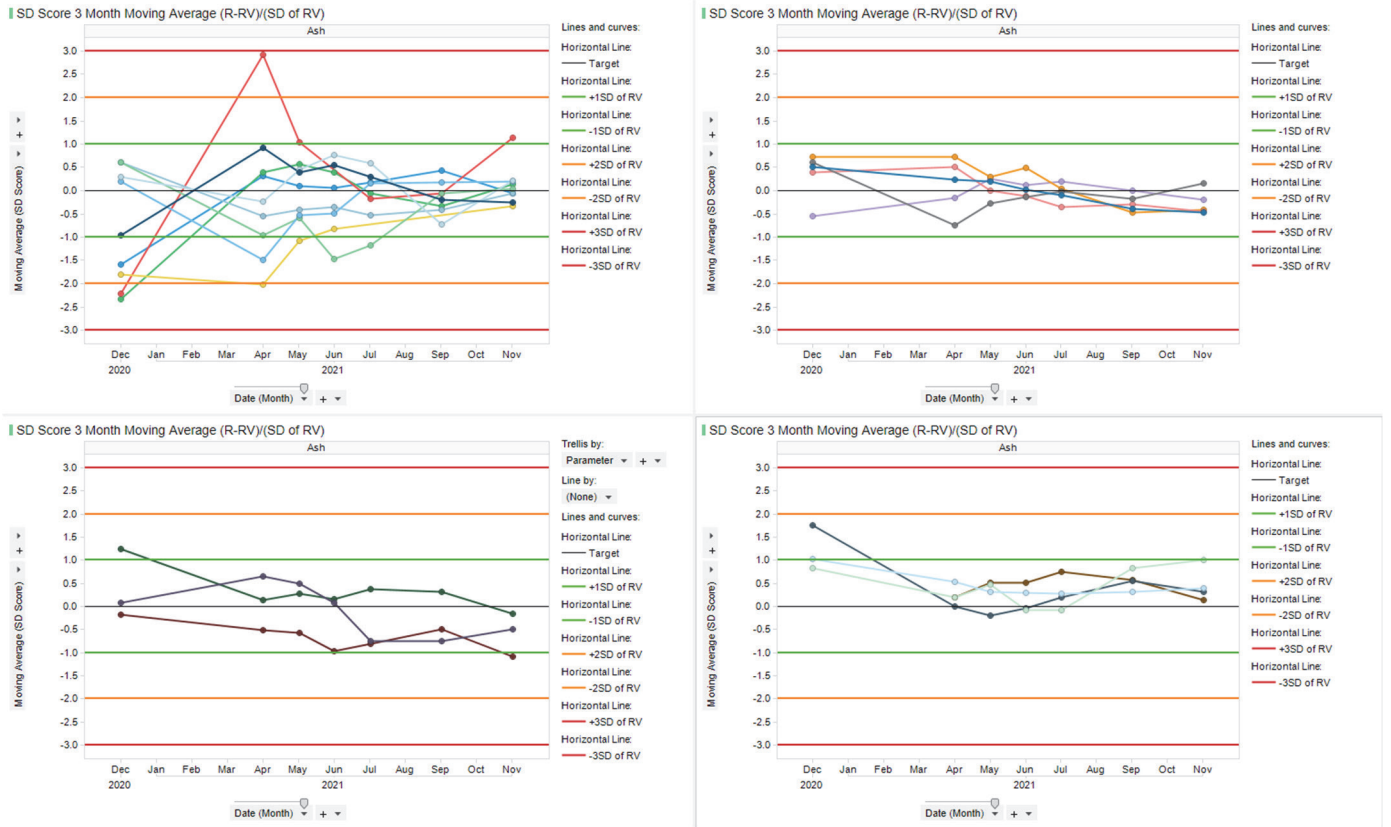

**Figure 4. Standard score 3 month moving average plot for individual laboratories across 4 different organisations for ash.**

Because of the logistical challenges related to the quality management of >20 laboratories, in different sites across the coal quality supply chain, as a first step towards the proactive approach, laboratory internal QC data is supplied from all the laboratories and imported into a QC dashboard which allows the company to regularly review the internal QAQC processes used to review assay results by batch before reporting. **Figure 5**, shows the difference between each QC sample result and the QC sample’s reference value. This visualisation enables the direct assessment of individual laboratories on a short term perspective, enabling the monitoring and detection of emerging trends or bias more proactively than the old assessment every 18 months.

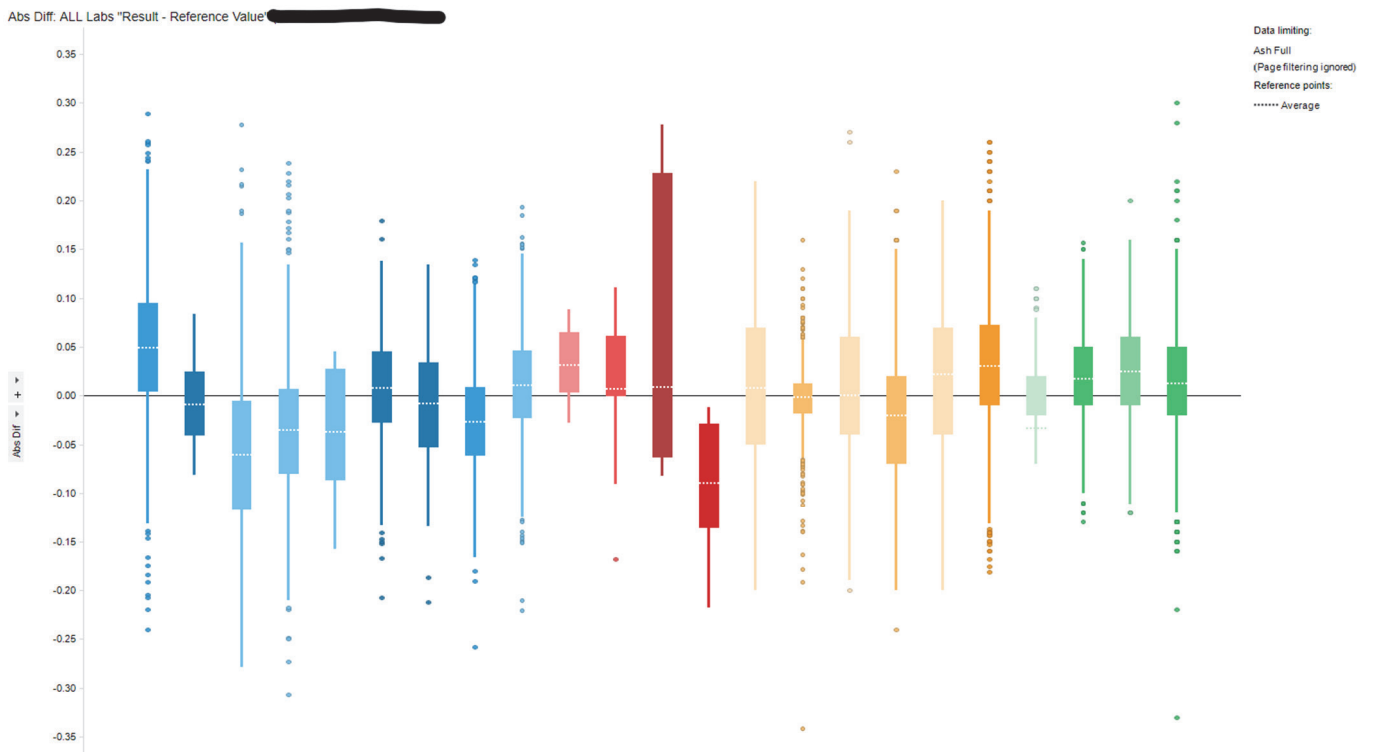

**Figure 5. Box Whisker plot of QC data (difference between QC result in each assay batch and QV reference value) for**

individual laboratories across 4 different organisations for ash.

Figure 6, shows the daily QC run chart (difference between QC result in each assay batch and QV reference value) and monthly Box Whisker plots of QC data for 3 laboratories in the same organisations for ash. This visualisation enables the identification of emerging trends or bias at each individual laboratory and also the potential impact of final reconciliation and financial /marketing results.

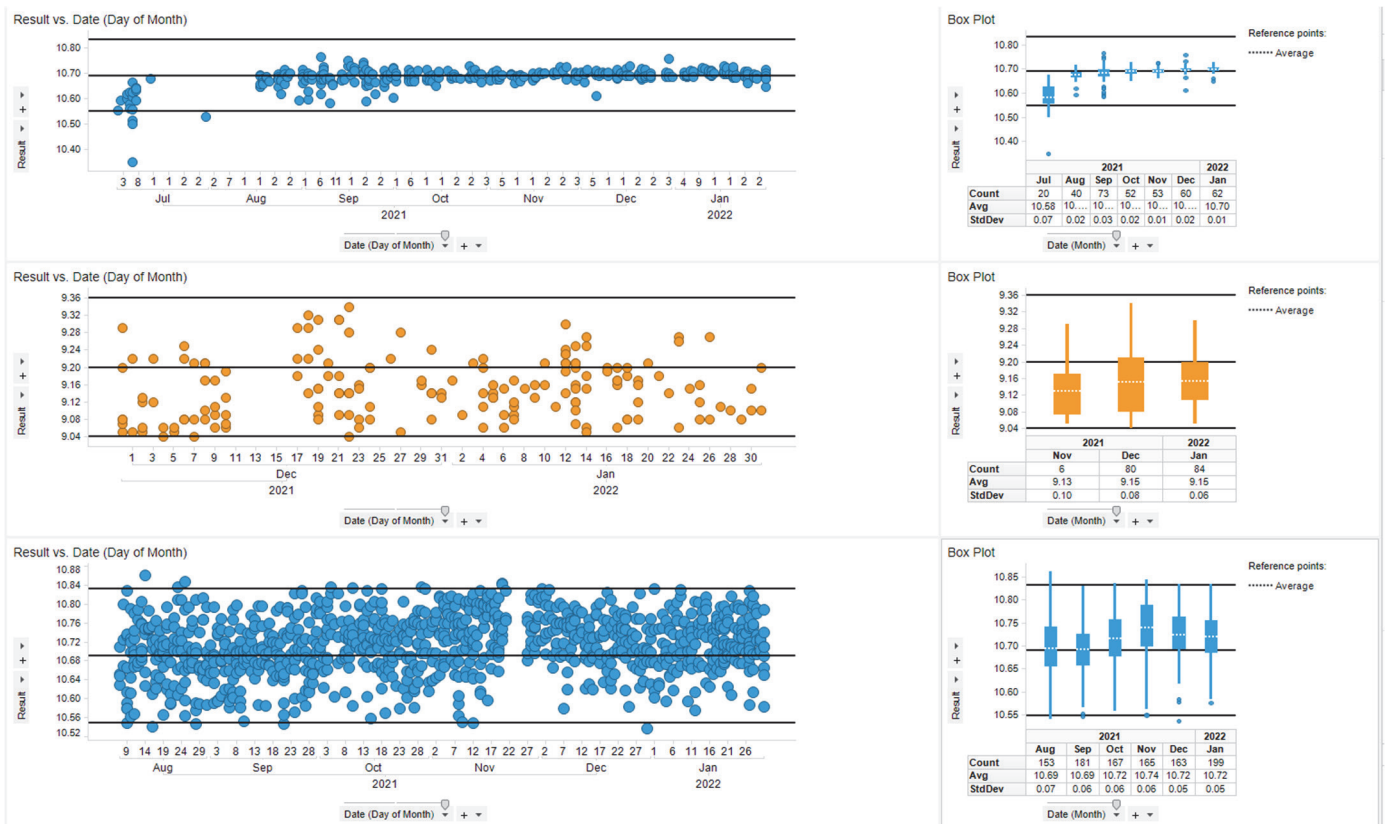

Figure 6. Daily QC run chart (difference between QC result in each assay batch and QV reference value) and monthly Box Whisker plots of QC data for 3 laboratories in the same organisations for ash.

- In addition, normal contract review meetings with laboratories can now include:
  - The review of this information in order to compare the individual laboratories within the organisation, and discussions of the outcomes of the company’s review of QAQC activities conducted between meetings.
  - Benchmark individual laboratories within the same company, but also between companies.
  - The monitoring of the progress of any actions raised to address any findings raised during any of the proactive QAQC review processes described above.

Conclusion

There are many benefits for implementing a proactive QAQC and QM program. Issues that impact on the quality (precision/accuracy) of the results reported by laboratories have the potential of resulting in unplanned out of specification product, creating even more workload and stress for companies that operate in a resource constrained environment. A proactive approach on QAQC and QM in the coal industry, as described in this paper, would identify these types of accuracy and precision gaps before they become an issue.

Using a visualisation product, such as Spotfire or Power BI, significantly reduces the time it takes to create them, once the importing template database has been created.

The use of a pulverised reference material (Coal RM) is important to eliminate the potential misleading conclusions from samples that need to be prepared and analysed i.e., sampling and preparation errors are significantly minimised from the equation.

It is essential to regularly receive and review laboratory internal QC data in order to closely monitor quality. Reliance on the laboratory or leaving the review of this data to the 18 month NATA ISO 17025 accreditation audits to identify and react to emerging trends and bias is not at all proactive.

A proactive QAQC and QM program enables better inputs into the reconciliation process, emerging trends and bias are identified long before they become a problem which means better financial outcomes for port and marketing.

This paper describes the beginning of a journey, there are more milestones currently in progress to achieve an even more robust proactive approach to QAQC and QM.

### ORCID iDs

J. Kelly: <https://orcid.org/0000-0002-7937-9441>

O. Dominguez:

### References

1. ISO 17025, “General requirements for the competence of testing and calibration laboratories”.
2. O. Dominguez, “Quality Assurance, Quality Control (QAQC) & Quality Management (QM) programs on Sample Stations: A prerequisite to achieve standards requirements”, *Proceedings 9<sup>th</sup> World Conference on Sampling and Blending (WCSB9)*. Beijing 2019. Page 552.



## Differentiating Analytical Error from Sampling Errors in PAT Methods through Variographic Analysis

J. Puche<sup>a</sup>, R.J. Romañach,<sup>a\*</sup> N. Sierra Vega<sup>b</sup>, R. Méndez<sup>b</sup>.

<sup>a</sup> Department of Chemistry, University of Puerto Rico at Mayagüez, Puerto Rico. E-mail, [jose.puche@upr.edu](mailto:jose.puche@upr.edu)

<sup>a</sup> Department of Chemistry, University of Puerto Rico at Mayagüez, Puerto Rico. E-mail [rodolfoj.romanach@upr.edu](mailto:rodolfoj.romanach@upr.edu)

<sup>b</sup>Department of Chemical Engineering, University of Puerto Rico at Mayagüez, Puerto Rico. E-mail: [nobel.sierra@upr.edu](mailto:nobel.sierra@upr.edu)

<sup>b</sup>Department of Chemical Engineering, University of Puerto Rico at Mayagüez, Puerto Rico. E-mail: [rafael.mendez1@upr.edu](mailto:rafael.mendez1@upr.edu)

**In variographic analysis the nugget effect provides an estimate of the total process measurement system error. The value of variographic analysis can be further increased by differentiating the analytical error from the sampling errors. The ratio of the minimum practical error (MPE) to the analytical error provides an estimate of the suitability and performance of a sampling system since the analytical error would still remain even if sampling errors could be completely eliminated. The sampling and analytical errors for four systems used to obtain 1-D lots of pharmaceutical powder blends is presented. The first studies were conducted with blends moving over a conveyor belt and with the feed-frame of a tablet press. The researchers then developed and patented a new stream sampler and chute for sampling and analysis of pharmaceutical powder blends. Near Infrared or Raman spectra were obtained as the powder blends flowed or moved and used to determine the drug concentration in the blends. Even though these methods do not require sample extraction and sample preparation in a laboratory, they are still subject to sampling errors which were estimated through the variographic analysis. The MPE was compared to the analytical error for these four systems. The results obtained show that it is often possible to reduce sampling errors to less than ten times the analytical error. These studies represent the first efforts to estimate and reduce sampling errors in the analysis of the powder blends used to manufacture the tablets that many patients take daily.**

### Introduction

In 2004 the Food and Drug Administration published its Process Analytical Technology (PAT) Guidance to encourage innovative pharmaceutical development, manufacturing, and quality assurance.<sup>1</sup> The agency defined PAT as a “system for designing, analyzing, and controlling manufacturing through timely measurements (i.e., during processing) of critical quality and performance attributes of raw and in-process materials and processes, with the goal of ensuring final product quality”. This guidance recognizes that the raw materials used in a process may show some variation in their physical properties and chemical composition. However, the manufacturing process may be controlled using the information provided by the real time analyses.

The real time analysis is performed through fast non-destructive analytical techniques such as near infrared and Raman spectroscopy. The PAT system differs significantly from many pharmaceutical processes that depend on performing an operation for a certain time, without any monitoring of the process, relying on testing after the production process has been completed. However, PAT systems are also affected by sampling errors.<sup>2, 3</sup> This research group is focused on studying the analytical and sampling errors in PAT for pharmaceutical manufacturing. In all the systems under study a 3-D system is transformed to a 1-D system making variographic analysis possible. The group first performed this transformation which permitted analyses in conveyor belts and the feed-frame of a tablet press.<sup>4-8</sup> The group then developed and patented a new stream sampler and chute for sampling and analysis of pharmaceutical powder blends.<sup>9-12</sup>

Variographic analysis permits the estimation of the sum of analytical and sampling errors through the nugget effect as indicated in a number of previous studies.<sup>13-15</sup> However, there is also a need to differentiate the sampling errors from the analytical errors. The analytical error may be estimated through a repeatability or short-term precision study. The repeatability study consists of six or more consecutive spectra on the same sample (the sample does not move or

flow while the spectra are obtained). The group has performed repeatability studies in every project where variographic analysis was performed.

Several previous studies from the TOS community have indicated that the sampling error is often 2 – 3 orders of magnitude larger than the analytical error.<sup>16-18</sup> However, if sampling systems were to be fully optimized, the sampling errors would approach the magnitude of the analytical error. Analytical methods will always be subject to an unavoidable random error.<sup>19</sup> This study describes a quantitative effort to investigate the ratio of sampling and analytical errors in PAT methods with 1-D sampling and variographic analysis. The repeatability study is used as a measure of the Total Analytical Error (TAE) and compared to the minimum practical error (MPE) obtained through variographic analysis.<sup>16</sup> The MPE should be of higher magnitude since it provides an estimate of both the sampling and analytical errors. The MPE should approach the variance of the repeatability study as the sampling system is improved. As the sampling system is improved the ratio of the MPE and the repeatability study should approach a value of 1. This hypothesis is evaluated by comparison of the results of four sampling systems including: a conveyor belt<sup>4</sup>, freed frame<sup>7, 8, 20-22</sup> stream sampler<sup>10-12</sup> and chute<sup>23</sup>, which have used for sampling and analysis of pharmaceutical blends.

## Experimental

### 1-D Sampling Systems:

A total of four 1-D sampling systems have been developed for analysis of powder blends. In these systems the powder blend is not removed for analysis at a laboratory. Near infrared or Raman spectroscopy are used to obtain spectra of the powders, providing real-time non-destructive analysis. When NIR spectroscopy is used, 32 scans are averaged into a single spectrum. A composite sample is obtained since the material is flowing or moving as the scans are obtained. The active pharmaceutical ingredient (API) concentration was predicted through a partial least squares (PLS) regression calibration model for each single spectrum.<sup>3</sup> The lag distance between pairs of drug concentration values was used in the calculation of variograms.

The first 1-D sampling system used was a conveyor belt.<sup>4-6</sup> The pharmaceutical powder mixture was deposited on a 3 m long rig with 10 cm width that moved at a linear velocity of 10 mm/s over the conveyor belt. The NIR spectra were obtained while in motion, at a point further along the conveyor belt. The fiber optic probe is fixed over the conveyor belt as shown in Figure 1.<sup>4</sup>

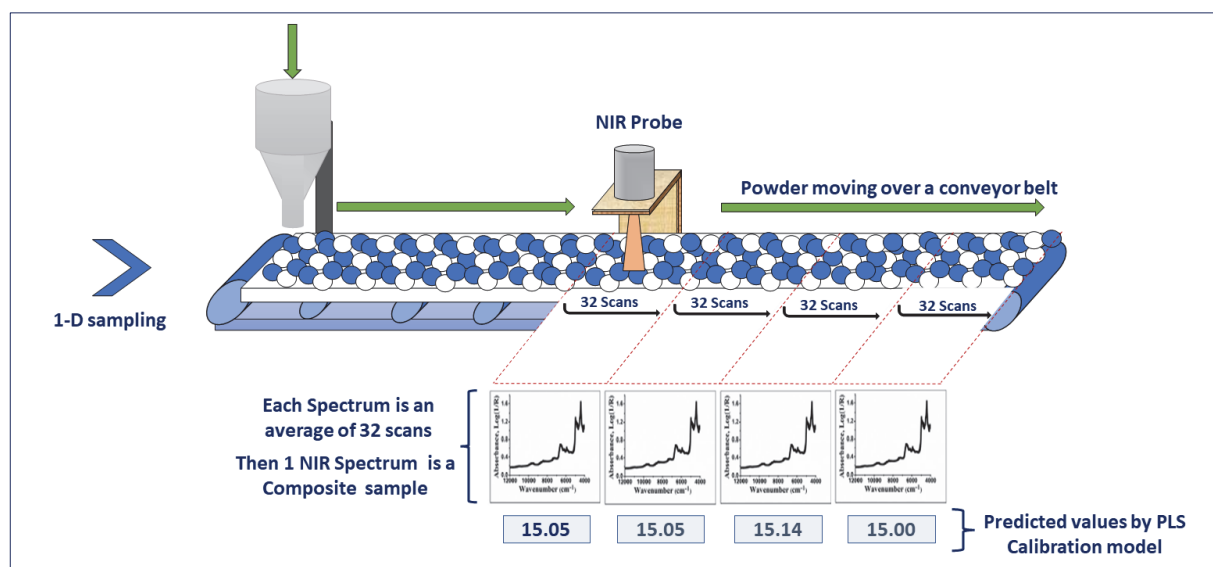

**Figure 1. NIR spectral acquisition in a 1-D optical sampling system for a conveyor belt**

The second experimental set up consisted of a hopper, a feed frame from a Fette 3090 tablet press (Fill-O-Matic, Fette Compacting, Schwarzenbek, Germany) adapted on a table and high-density polyethylene disc. The thickness of the disc is 12.5 mm and has 36 holes of 10 mm diameter each one. This set up is used to simulate the tablet press turret.<sup>20, 24</sup> Figure 2 shows the experimental set-up for the feed frame sampling system.

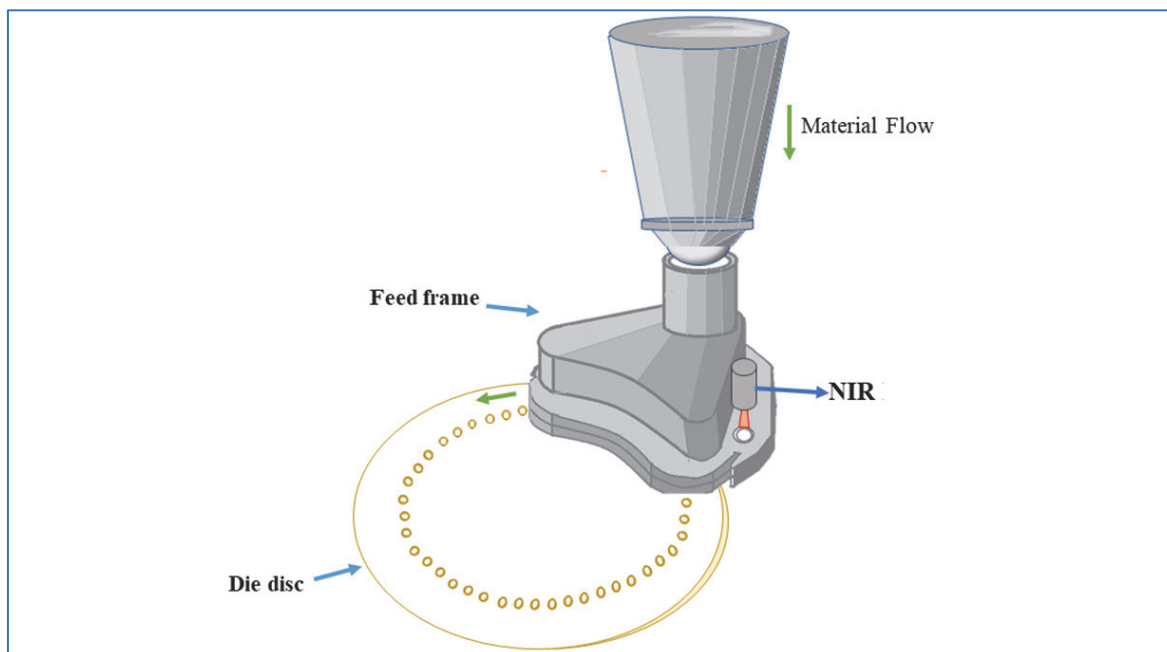
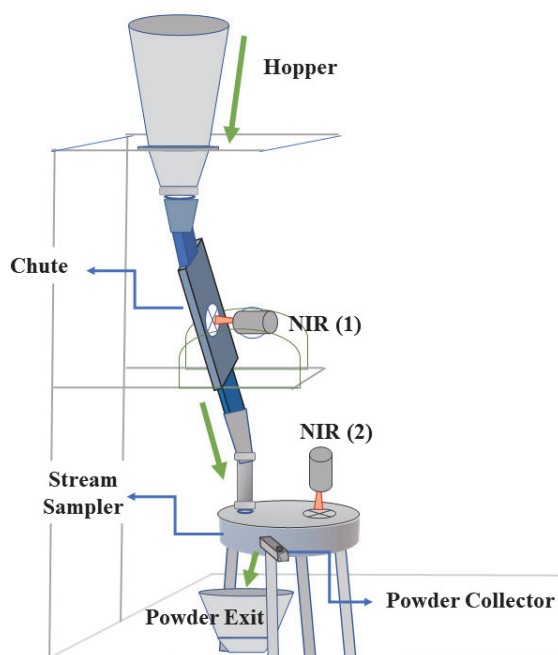

**Figure 2. Example experimental set-up for a feed frame sampling system**

The feed frame consists of three chambers, it has two levels and two inspection windows. The distributing chamber receives the powder from the hopper and transports it, using a paddle wheel, to fill and to set the dose to the chambers through two orifices in the partition plate<sup>20, 24</sup>. The paddle wheel speed and die disc speed were varied in a number of experiments. The procedure is to add powder blend to the hopper; while the paddle wheel and die disc stand still. The feed frame is turned on and it transports the powders to the chambers and inspection windows, where the NIR probe is installed over the left sapphire window to acquire spectra.

Figure 3 shows: 1) the transition chute and NIR (2) and stream sampler where spectra can be obtained.<sup>23</sup> The chute and stream sampler were designed to comply with the Fundamental Sampling Principle (FSP) which stipulates that all parts of the lot must have the same opportunity to be selected, and samples should be collected without affecting the material composition<sup>3, 14</sup>. The transition chute has a length of 41 cm a 15 cm width, with a 1 cm thickness and 2.54 cm diameter. The NIR spectra collected at the chute are obtained through a sapphire window placed 30 cm after the entry of the flowing powder. The chute is placed at an angle of 75 degrees as shown in Figure 3. The force of gravity and stream sampler revolutions allows the flowing powder blend to pass through the chute, generating more stability and continuity in the powder flow.<sup>23</sup>





**Figure 3. Schematic of the experimental sampling system set-up for the chute and the stream sampler.**

The stream sampler has a chamber of approximately 150 mm diameter. The powder flows into the chamber by a wheel of rectangular paddles with a 5 mm thickness, which rotate counterclockwise at controllable speeds. The center of the paddle wheel has a diameter of approximately 86 mm, more than fifty percent of capacity of stream sampler.<sup>9, 12</sup> The powder leaves the system at 270° after its entry, avoiding powder re-circulation and changes in the drug concentration. This design reduces the probability of attrition and rupture of particles, which could affect the heterogeneity in the material. At the top of stream sampler, there is a sapphire window in the cross section of the flow powder. The stream sampler has an off-line powder collector, this collector is slid into the sampler to acquire the powder sample from a full cross-section of flow area. The sampler uses a 1.56 cm<sup>3</sup> volume, stainless-steel cup. The sample collector is used to select and analyze samples with a reference method<sup>9, 10</sup> However, all the results described in this study were obtained as the powder flowed through the stream sampler. This study does not report work with the powder collector.

#### Multivariate data analysis

The calibration models were developed and evaluated using multivariate data analysis software. The algorithm used is based on nonlinear iterative partial least squares (NIPALS) algorithm.<sup>25</sup> In the development of the calibration models, the spectra can be transformed by mathematical pretreatments such as standard normal variate (SNV), first and second derivative (Savitzky-Golay algorithm), etc. The PLS model was evaluated with the Root Mean Square Error of Prediction (RMSEP), the Relative Standard Error of Prediction (RSEP), and bias as shown in equations 1 - 3.

$$RMSEP = \sqrt{\frac{\sum_{i=1}^m (\hat{y}_i - y_i)^2}{m}} \quad (1)$$

$$\%RSEP = 100 * \sqrt{\frac{\sum_{i=1}^m (\hat{y}_i - y_i)^2}{\sum_{i=1}^m (y_i)^2}} \quad (2)$$

$$Bias = \frac{\sum_{i=1}^m (\hat{y}_i - y_i)}{m} \quad (3)$$

#### Variographic analysis

Variographic analysis was performed to estimate the sampling and analytical errors in the in-line PAT measurements. Figure 4 shows an example used to illustrate the information provided by the variogram. The variograms were

generated through the use of a Matlab code (Matlab version R2013b, The Math Works, Natick, MA). The variograms were calculated according to Equation 4.

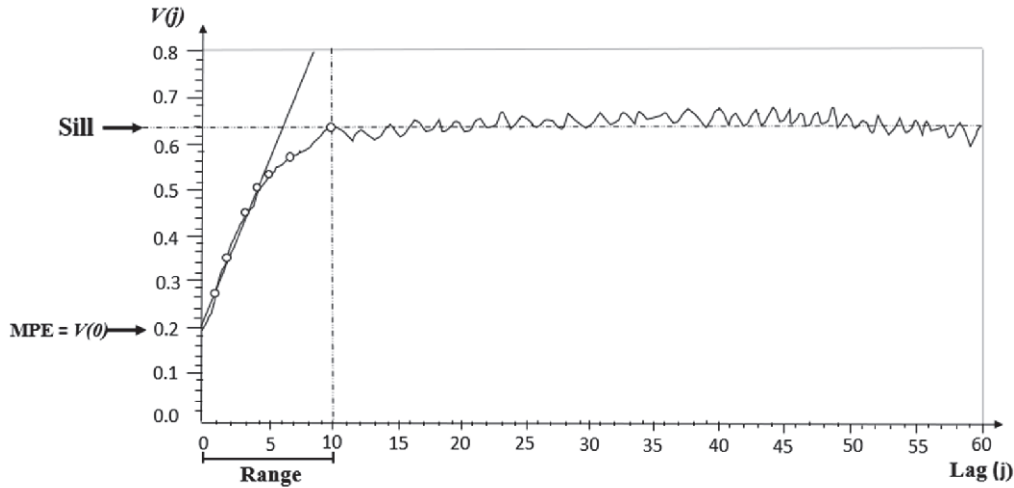

Figure 4. Example of variogram and variogram elements; Sill, MPE, Range, Lag (j) distance.

$$V(j) = \frac{1}{2(Q_{total} - j)} \sum_{q=1}^{Q_{total}-j} (h_{(q+j)} - h_q)^2 \tag{4}$$

The variogram function  $V(j)$ , represents the variation between the predicted drug concentration for the composite samples. The  $Q_{total}$  represents the total number of composite samples,  $h_{(q+j)}$  and  $h_q$  is the concentration value in each sampling point (expressed as the heterogeneity contribution). The  $j$  is the lag distance defined as the inverse of the sampling frequency in 1-D sampling. The lag is the distance between increments (or distance between samples) and can be expressed by time when the material is sampled <sup>4, 14-16</sup>.

Variographic analysis makes it possible to calculate the contribution errors in the measurements. The total error variance ( $S_0^2$ ) contribution to the analytical measurement uncertainty is: the sum of the sampling variance ( $S_s^2$ ) and analytical method variance ( $S_m^2$ ). Eq.5.

$$S_0^2 = S_s^2 + S_m^2 \tag{5}$$

The minimum practical error (MPE) – or nugget effect - is the minimum variance expected for any measurement situation, determined by back-extrapolating the first 3-5 points of  $V(j)$ . In Equation 6 it is possible to calculate the total sampling error (TSE), and the total analytical error (TAE) as a variance calculated by from the analytical repeatability study.

$$MPE = TSE(S_s^2) + TAE(S_m^2) \tag{6}$$

The sill is the mean variation of a variogram (the flat ceiling of the variogram). The ‘corrected-sill’ is calculated by subtracting the MPE from sill (relative to the dynamic of process and residual heterogeneity). The range is the lag at which the variogram becomes effectively constant <sup>15, 16</sup>.

**Procedure to performing the repeatability studies**

The analytical repeatability study was performed by obtaining six consecutive spectra of the same sample (without moving the fiber optic probe). The drug concentration associated with these spectra was determined through a PLS calibration model. The variance of the drug concentration obtained through the six consecutive spectra was then

calculated. The repeatability study was performed 3 to 10 times; then, the pooled variance was calculated as an estimation of total analytical error (TAE).<sup>4</sup>

### Data

The data shown in Tables 1 and 2 were obtained from previous publications by the present research group during the last five years.

### Materials

A number of active pharmaceutical ingredients (API) and excipients were used in the blends, The API used were metformin milled granules with a purity of 98 [%w/w]<sup>4</sup>, acetaminophen (APAP)<sup>7,8</sup>, ibuprofen powder<sup>11,22</sup>, anhydrous caffeine<sup>10,12,21,23</sup>. Microcrystalline cellulose, lactose monohydrate as excipients non-co-processed excipients, magnesium stearate as lubricant and colloidal silicon dioxide as glidant.

### Results

The four sampling systems were evaluated through variographic analysis. The repeatability study was used to estimate the TAE. The sampling error and total analytical error were differentiated through the ratio of the MPE and TAE. Table 1 shows the (MPE/TAE) ratio results of studies employing the conveyor belt or feed frame and spectrometer (NIR and/or Raman). The studies were performed with concentrations of the active pharmaceutical ingredients which varied from 3 to 100% (w/w), and with several common excipients.

**Table 1. Summary of studies performed with the conveyor belt and feed frame.**

Reference (#)	Sampling System	API	Conc. % (w/w)	MPE (%w/w) <sup>2</sup>	TAE (%w/w) <sup>2</sup>	MPE/TAE
4	Conveyor (NIRS) Model 1	Metformin	95.0	0.0513	0.0002	257
4	Conveyor (NIRS) Model 1	Metformin	97.0	0.0414	0.0002	207
4	Conveyor (NIRS) Model 1	Metformin	100.0	0.0013	0.0007	2
4	Conveyor (NIRS) Model 2	Metformin	95.0	0.0683	0.0002	342
4	Conveyor (NIRS) Model 2	Metformin	97.0	0.0559	0.0003	186
4	Conveyor (NIRS) Model 2	Metformin	100.0	0.0009	0.0010	1
4	Conveyor (NIRS) Model 3	Metformin	95.0	0.0750	0.0010	75
4	Conveyor (NIRS) Model 3	Metformin	97.0	0.0500	0.0010	50
4	Conveyor (NIRS) Model 3	Metformin	100.0	0.0005	0.0020	0.3
7	Feed Frame (NIRS)	acetaminophen	3.00	0.0023	0.00061	3.8
7	Feed Frame (NIRS)	acetaminophen	3.00	0.0020	0.00061	3.3

7	Feed Frame (NIRS)	acetaminophen	3.00	0.0034	0.00061	5.6
8	Feed Frame (NIRS)	acetaminophen	10.0	0.019	0.00012	158
22	Feed Frame (NIRS)	Ibuprofen (Co-processed excipients)	42.5	0.136	0.0365	3.73
22	Feed Frame (NIRS)	Ibuprofen (Co-processed excipients)	50.0	0.166	0.0160	10.4
22	Feed Frame (NIRS)	Ibuprofen (Co-processed excipients)	57.5	0.138	0.0788	1.75
22	Feed Frame (NIRS)	Ibuprofen (non-Co-processed excipients)	42.5	1.74	0.127	13.7
22	Feed Frame (NIRS)	Ibuprofen (non-Co-processed excipients)	50.0	1.88	0.215	8.74
22	Feed Frame (NIRS)	Ibuprofen (non-Co-processed excipients)	57.5	1.76	0.148	11.9
21	Feed Frame (NIRS)	Caffeine	4.00	0.0047	0.0016	2.9
21	Feed Frame (NIRS)	Caffeine	5.00	0.0061	0.00096	6.4
21	Feed Frame (NIRS)	Caffeine	6.00	0.0068	0.00078	8.7
21	Feed Frame (Raman)	Caffeine	4.00	0.046	0.00048	96
21	Feed Frame (Raman)	Caffeine	5.00	0.0389	0.00084	46
21	Feed Frame (Raman)	Caffeine	6.00	0.045	0.0012	38

#### Ratio of MPE to the TAE in the conveyor belt studies

The ratio of the MPE to the TAE on the conveyor belt varied from 0.3 to 342 as shown in Table 1. This very large variation is related to the heterogeneity of the blends. Table 1 shows three experiments with the conveyor belt, where the drug concentration was predicted with three calibration models.<sup>4</sup> Each calibration model had a different range of concentrations: 90-100 % (Model 1), 85-100% (Model 2) and 65-100 % w/w metformin (Model 3). Three test set blends with concentrations of: 95.0, 97.0 and 100.0 %w/w of metformin were predicted by the calibration models. The experiment was purposely designed with high concentrations to obtain blends with low heterogeneity. The use of the single component (100% w/w metformin granules) provided an opportunity to reduce the heterogeneity to a maximum level, and thereby quantify the analytical error. The MPE/TAE for the test set blends varied from 257 to 2 for Model 1, and from 342 to 1 for Model 2 and from 75 to 1 in Model 3. The lowest MPE/TAE were obtained, as expected, for the 100% (w/w) metformin granules.

Table 1 also shows three examples with the conveyor belt where the metformin concentration was predicted by NIR spectroscopy when only one material (metformin granules) was present in the conveyor belt. The use of a single component was done to minimize the heterogeneity and reduce the sampling errors. In this case the MPE/TAE values obtained were: 2, 1, and 0.3. These results show that the sampling error is minimized, and it approaches the TAE. The differences obtained were related to the calibration model used to predict the drug concentration. The MPE/TAE of 2 was obtained with a calibration model which included blends that varied from 90 to 100% w/w. The MPE/TAE of 1 was obtained with a different calibration model which included blends that varied from 85 to 100% w/w. The MPE/TAE of 0.3 was obtained with a different calibration model which included blends that varied from 65 to 100% w/w. These experiments confirm that the MPE was reduced by using a material with a low heterogeneity.

Figure 5A shows the variograms of a test set blend with 95% w/w metformin analyzed in the conveyor belt. Figure 5B shows the variogram for the 100% w/w metformin. The MPE is 150 times lower in the 100% (w/w) metformin granules. The greater heterogeneity of the 95% w/w metformin resulted in the larger MPE.

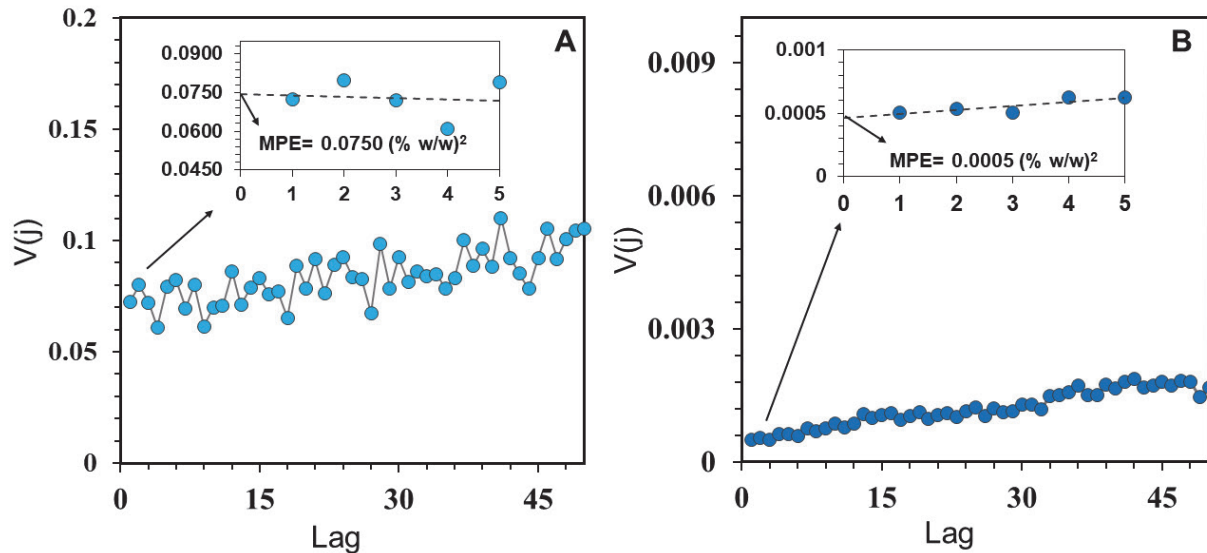
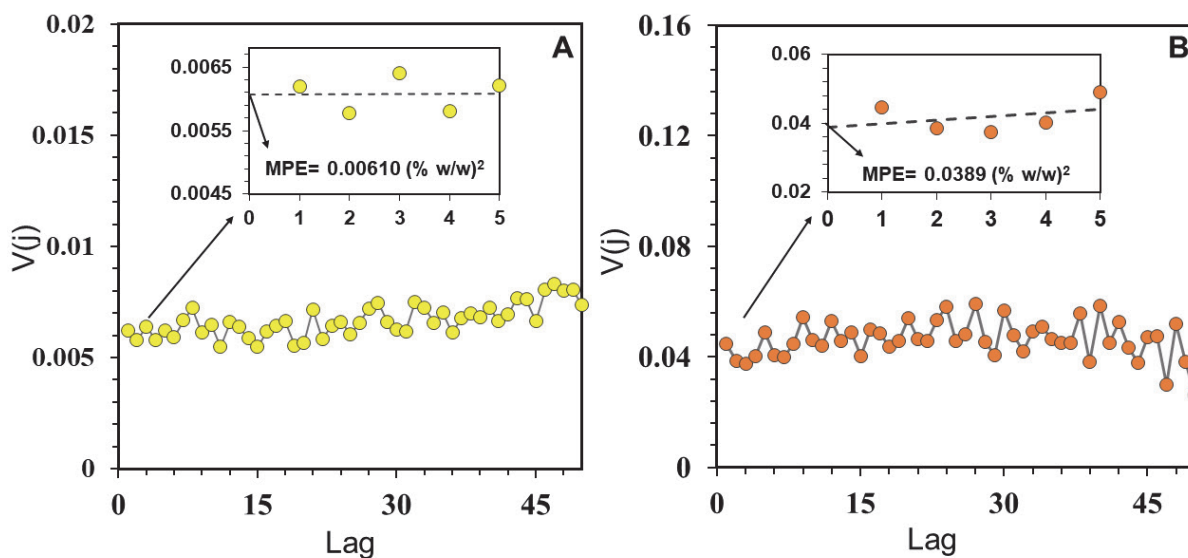

**Figure 5. Comparison of variograms of test set blend 95 % w/w (A) and 100 % w/w (B) of API obtained over conveyor belt with NIR spectrometer.**

The ratio of the MPE to the TAE in the feed frame

The ratio of the MPE to the TAE in the feed frame varied from 2.9 to 158. The feed frame was used with materials with a wide range of physical properties. The ratio of 158 was obtained at the continuous manufacturing facility at Rutgers, and it includes the effects of various components of the manufacturing line.<sup>8</sup> The experimental set-up is more complex than in other studies where the feed-frame was used. These results were also with acetaminophen, a cohesive material that affects flow properties.

Table 1 shows another case, the comparison of spectrometers in the simultaneous analysis of drug concentration, the NIR and Raman spectra was obtained over the feed frame of the tablet press.<sup>21</sup> Figure 6 shows the variograms for the test blend of 5 % w/w caffeine, the MPE is 6 times less when the NIR is used. The TAE is similar when using each spectrometer, but the ratio (MPE/TAE) is 6.4 for NIR and 46 with Raman spectroscopy. The difference of ratio obtained suggests a larger sampling error when using a Raman spectrometer. More studies of this difference will be illuminating.



**Figure 6. Comparison of variograms of test set blend of 5% by NIR(A) and Raman (B) in simultaneous analysis.**

**Ratio of MPE to the TAE in the stream sampler and chute**

Table 2 shows the (MPE/TAE) ratio results of studies employing the stream sampler and the chute respectively. The results obtained with the stream sampler varied from 1.3 to 34. The first study with the stream sampler involved the prediction of test set blends with 12.00, 15.00, and 18.00% w/w caffeine.<sup>10</sup> The MPE/TAE ranged from 2.3 – 3.4 for these test set blends. The second study with the stream sampler involved test set blends with only 2.00, 3.00 and 4.00 % w/w ibuprofen in cohesive powder blends.<sup>11</sup> The MPE/TAE for these blends varied from 7.6 – 24. The greater ratio may be due to the cohesiveness of these powder blends, which influence the powder flowability. The stream sampler was also used with low drug concentration powder blends where the concentration of caffeine in the test set blends ranged from 0.76 – 4.02 % w/w.<sup>12</sup> The MPE/TAE for these blends varied from 2.9 to 34.

The results obtained with the patented chute, used in the experimental setup illustrated in Figure 2, are also shown in Table 2.<sup>23</sup> The MPE/TAE varied from 29 to 153 for these blends. These are preliminary results with the chute, and additional studies are planned.

**Table 2. Studies performed with stream sampler and chute.**

Reference (#)	Sampling System	API	Conc. % (w/w)	MPE(%w/w) <sup>2</sup>	TAE(%w/w) <sup>2</sup>	MPE/TAE
10	Stream sampler (NIRS)	Caffeine	12.00	0.192	0.083	2.3
10	Stream sampler (NIRS)	Caffeine	15.00	0.217	0.083	2.6
10	Stream sampler (NIRS)	Caffeine	18.00	0.279	0.083	3.4

11	Stream sampler (NIRS)	Ibuprofen	2.00	0.0044	$5.8 \times 10^{-4}$	7.6
11	Stream sampler (NIRS)	Ibuprofen	3.00	0.0076	$9.3 \times 10^{-4}$	8.2
11	Stream sampler (NIRS)	Ibuprofen	4.00	0.0104	$4.4 \times 10^{-4}$	24
12	Stream sampler (NIRS)	Caffeine	2.02	0.0019	$5.6 \times 10^{-5}$	34
12	Stream sampler (NIRS)	Caffeine	3.09	0.0042	$3.6 \times 10^{-4}$	12
12	Stream sampler (NIRS)	Caffeine	4.02	0.0034	$2.3 \times 10^{-4}$	15
12	Stream sampler (NIRS)	Caffeine	0.76	0.0020	$6.8 \times 10^{-4}$	2.9
12	Stream sampler (NIRS)	Caffeine	1.51	0.0018	$3.6 \times 10^{-4}$	5.0
12	Stream sampler (NIRS)	Caffeine	2.26	0.0028	$2.2 \times 10^{-4}$	13
23	Chute (NIRS)	Caffeine	2.02	0.0041	$9.3 \times 10^{-5}$	44
23	Chute (NIRS)	Caffeine	3.09	0.0094	$3.2 \times 10^{-4}$	29
23	Chute (NIRS)	Caffeine	4.02	0.011	$7.2 \times 10^{-5}$	153

## Conclusion

The hypothesis in this work was that improvements in a sampling system could lead to an MPE/TAE value as low as of 1 in the best of all possible cases. This assessment may be used to improve the performance of powder samplers. The MPE and TAE were compared in four different sampling systems. The results obtained indicate that this ratio is a valuable source of information with which to compare sampling performance of PAT systems. This is the first comparison of MPE and TAE in pharmaceutical PAT systems.

The use of the single component (100% w/w metformin granules) reduced the heterogeneity to a minimum level and indeed provided MPE/TAE values close to 1. Metformin blends of 95% and 97% (w/w) blends were also analyzed, but the lowest MPE/TAE values were obtained, as expected, for the 100% (w/w) metformin granules.

This kind of performance comparison is only possible in PAT systems where 1-D sampling and variographic analysis are performed. The value of TOS for PAT applications is evident.

## ORCID iDs

J. Puche: 0000-0001-5060-5401

R.J. Romañach: 0000-0001-7513-7261

N. Sierra Vega: 0000-0002-2242-1127

R. Méndez: 0000-0003-3396-4538

## References

1. F.D.A. U.S. Department of Health and Human Services, "Guidance for Industry - Pat a Framework for Innovative Pharmaceutical Development, Manufacturing, and Quality Assurance," pp. 1 (2004).
2. K.H. Esbensen and P. Paasch-Mortensen, "Process Sampling: Theory of Sampling – the Missing Link in Process Analytical Technologies (Pat)", in *Process Analytical Technology*, Ed by K. Bakeev. John Wiley & Sons, Ltd, Chichester, West Sussex, PO19 8SQ, United Kingdom, pp. 37 (2010).
3. K.H. Esbensen, *Introduction to the Theory and Practice of Sampling*. IMP Open, Chichester, West Sussex PO18 0HY, UK (2020).
4. A. Sánchez-Paternina, N.O. Sierra-Vega, V. Cárdenas, R. Méndez, K.H. Esbensen and R.J. Romañach, "Variographic Analysis: A New Methodology for Quality Assurance of Pharmaceutical Blending Processes", *Computers & Chemical Engineering* **124**, 109 (2019). doi: <http://dx.doi.org/https://doi.org/10.1016/j.compchemeng.2019.02.010>
5. A. Sánchez-Paternina, A. Román-Ospino, C. Ortega-Zuñiga, B. Alvarado, K. Esbensen and R. Romañach, "When "Homogeneity" Is Expected—Theory of Sampling in Pharmaceutical Manufacturing", *TOS Forum* **67** (2015). doi: <http://dx.doi.org/10.1255/tosf.61>
6. A. Roman-Ospino, C. Ortega-Zuñiga, A. Sanchez-Paternina, S. Ortiz, K. Esbensen and R. Romañach, "Estimating Total Sampling Error for near Infrared Spectroscopic Analysis of Pharmaceutical Blends—Theory of Sampling to the Rescue", *TOS Forum* **71** (2015). doi: <http://dx.doi.org/https://doi.org/10.1255/tosf.66>
7. N.O. Sierra-Vega, A. Sánchez-Paternina, N. Maldonado, V. Cárdenas, R.J. Romañach and R. Méndez, "In Line Monitoring of the Powder Flow Behavior and Drug Content in a Fette 3090 Feed Frame at Different Operating Conditions Using near Infrared Spectroscopy", *J. Pharm. Biomed. Anal.* **154**, 384 (2018). doi: <http://dx.doi.org/https://doi.org/10.1016/j.jpba.2018.03.017>
8. N.O. Sierra-Vega, A. Román-Ospino, J. Scicolone, F.J. Muzzio, R.J. Romañach and R. Méndez, "Assessment of Blend Uniformity in a Continuous Tablet Manufacturing Process", *Int. J. Pharm.* **560**, 322 (2019). doi: <http://dx.doi.org/https://doi.org/10.1016/j.ijpharm.2019.01.073>
9. R.J. Romañach and Mendez, Rafael *Stream Sampler—Mass Reduction System for Flowing Powders*. Patent 10520400 (2019).
10. B.B. Alvarado-Hernández, N.O. Sierra-Vega, P. Martínez-Cartagena, M. Hormaza, R. Méndez and R.J. Romañach, "A Sampling System for Flowing Powders Based on the Theory of Sampling", *Int. J. Pharm.* **574**, 118874 (2020). doi: <http://dx.doi.org/https://doi.org/10.1016/j.ijpharm.2019.118874>
11. N.O. Sierra-Vega, R.J. Romañach and R. Méndez, "Real-Time Quantification of Low-Dose Cohesive Formulations within a Sampling Interface for Flowing Powders", *Int. J. Pharm.* **588**, 119726 (2020). doi: <http://dx.doi.org/https://doi.org/10.1016/j.ijpharm.2020.119726>
12. N.O. Sierra-Vega, P.A. Martínez-Cartagena, B.B. Alvarado-Hernández, R.J. Romañach and R. Méndez, "In-Line Monitoring of Low Drug Concentration of Flowing Powders in a New Sampler Device", *Int. J. Pharm.* **583**, 119358 (2020). doi: <http://dx.doi.org/https://doi.org/10.1016/j.ijpharm.2020.119358>
13. K.H. Esbensen, A.D. Román-Ospino, A. Sanchez and R.J. Romañach, "Adequacy and Verifiability of Pharmaceutical Mixtures and Dose Units by Variographic Analysis (Theory of Sampling) – a Call for a Regulatory Paradigm Shift", *Int. J. Pharm.* **499**, 156 (2016). doi: <http://dx.doi.org/http://dx.doi.org/10.1016/j.ijpharm.2015.12.038>
14. K.H. Esbensen, R.J. Romañach and A.D. Román-Ospino, "Chapter 4 - Theory of Sampling (Tos): A Necessary and Sufficient Guarantee for Reliable Multivariate Data Analysis in Pharmaceutical Manufacturing ", in *Multivariate Analysis in the Pharmaceutical Industry*, Ed by A.P. Ferreira, J.C. Menezes and M. Toby. Academic Press, London, United Kingdom, pp. 53 (2018).
15. K.H. Esbensen and R.J. Romañach, "A Framework for Representative Sampling for Nir Analysis—Theory of Sampling (Tos)", in *Handbook of near-Infrared Analysis*, Ed by E.W. Ciurczak, B. Igne, J. Workman and D.B. Burns. Taylor & Francis Group, Boca Raton, Fla, (2021).
16. K.H. Esbensen and L.P. Julius, "Representative Sampling, Data Quality, Validation - a Necessary Trinity in Chemometrics", *Comprehensive Chemometrics: Chemical and Biochemical Data Analysis*, Vols 1-4 C1 (2009). doi: <http://dx.doi.org/10.1016/j.chembolab.2004.05.012>
17. P. Gy, "Sampling of Discrete Materials - a New Introduction to the Theory of Sampling - I. Qualitative Approach", *Chemometrics Intellig. Lab. Syst.* **74**, 7 (2004). doi: <http://dx.doi.org/10.1016/j.chembolab.2004.05.012>
18. P. Minkinen, "Evaluation of the Fundamental Sampling Error in the Sampling of Particulate Solids ", *Analytica Chimica Acta* **196**, 237 (1987). doi: [http://dx.doi.org/10.1016/s0003-2670\(00\)83089-5](http://dx.doi.org/10.1016/s0003-2670(00)83089-5)
19. R. Romañach , A. Joubert Castro and K. Esbensen, "What Are Sampling Errors—and What Can We Do About Them? Part 1", *Spectroscopy Europe* **33**, 7 (2021). doi: [http://dx.doi.org/10.1016/s0003-2670\(00\)83089-5](http://dx.doi.org/10.1016/s0003-2670(00)83089-5)



20. N.O. Sierra-Vega, R.J. Romañach and R. Méndez, "Feed Frame: The Last Processing Step before the Tablet Compaction in Pharmaceutical Manufacturing", *Int. J. Pharm.* **572**, 118728 (2019). doi: <http://dx.doi.org/https://doi.org/10.1016/j.ijpharm.2019.118728>
21. N.O. Sierra-Vega, R.A. González-Rosario, R.S. Rangel-Gil, R.J. Romañach and R. Méndez, "Quantitative Analysis of Blend Uniformity within a Three-Chamber Feed Frame Using Simultaneously Raman and near-Infrared Spectroscopy", *Int. J. Pharm.* **613**, 121417 (2022). doi: <http://dx.doi.org/https://doi.org/10.1016/j.ijpharm.2021.121417>
22. N.O. Sierra-Vega, K.M. Karry, R.J. Romañach and R. Méndez, "Monitoring of High-Load Dose Formulations Based on Co-Processed and Non Co-Processed Excipients", *Int. J. Pharm.* **606**, 120910 (2021). doi: <http://dx.doi.org/https://doi.org/10.1016/j.ijpharm.2021.120910>
23. P.A. Martínez-Cartagena, N.O. Sierra-Vega, B.B. Alvarado-Hernández, R. Méndez and R.J. Romañach, "An Innovative Sampling Interface for Monitoring Flowing Pharmaceutical Powder Mixtures", *J. Pharm. Biomed. Anal.* **194**, 113785 (2021). doi: <http://dx.doi.org/10.1016/j.jpba.2020.113785>
24. D. Mateo-Ortiz, Y. Colon, R.J. Romanach and R. Mendez, "Analysis of Powder Phenomena inside a Fette 3090 Feed Frame Using in-Line Nir Spectroscopy", *J. Pharm. Biomed. Anal.* **100**, 40 (2014). doi: <http://dx.doi.org/10.1016/j.jpba.2014.07.014>
25. K.E. Esbensen and B. Swarbrick, *Multivariate Data Analysis – in Practice. An Introduction to Multivariate Analysis, Process Analytical Technology and Quality by Design*. CAMO Software AS, Oslo, Norway (2018).

## Comminution sizes in sampling calculations

D. Francois-Bongarcon<sup>a</sup> and R. Oliver<sup>b</sup>

<sup>a</sup> AGORATEK International Consultants Inc. (AICI) E-mail: dfbgn2@gmail.com

<sup>b</sup> formerly Intertek Laboratory, Jakarta

As was demonstrated by Gy empirically, then elucidated by Francois-Bongarcon, only the P95 size of comminuted material (i.e. the size of a screen rejecting 5% of the material in mass) is relevant to sampling theory variance formulas. In practice, when establishing sampling nomograms or using historic data for heterogeneity testing, the P95 is not always known and the material is not always preserved for P95 determinations by screening. A non-theoretical study of the experimental material previously used and published by Gy had suggested some unpublished, rule-of-thumb, order-of-magnitude correspondence between other Pxx sizes (e.g. P100, P80, P75, etc.) and P95, to be used as a last resort when no better determination is possible. This correspondence surprisingly followed an arithmetic progression. In this paper, various types of size distributions were researched and most of these rule-of-thumb formulas were reasonably confirmed, except for the correspondence between P95 and P100 (maximum size), which was therefore updated. The reasons for the arithmetic progression and its exception for P100 also became clearer in the process.

### Introduction

In the process of establishing a numerical model (formula) for the relative variance of the fundamental sampling error, Gy stumbled on two problems: defining the comminution size using a single size parameter (nominal size) and relating it to the average fragment volume weighted by mass, in the lot to be sampled. In his well known formula:

$$\text{Rel.Var.} = \text{cfg} \ell d^3 (1/M_s - 1/M_L) \quad (1)$$

indeed, the term  $\text{fgd}^3$  intends to represent that average quantity. It includes the chosen nominal size  $d$ , a shape factor  $f$  that transforms the cube of that size into a volume, and the granulometric factor  $g$ , which pretends to transform the nominal volume  $fd^3$  into the mass-weighted average volume in the lot.

This feat was not obvious from the start. Defining the comminution degree using a single parameter had been done before using a "percent passing" size, and Gy decided not to innovate there. But which percentage passing was to be used? And how could it be miraculously related to the average volume in the entire distribution of fragments, irrespective of the type of material and comminution, using a simple multiplicative and universal constant  $g$ ? As it turned out, it is indeed possible, but only if we restrict the definition of the comminution degree to the use of a 95% passing size (a.k.a. P95) for  $d$  and use an approximate value of 0.25 for constant  $g$ . That has been described and demonstrated <sup>1</sup>.

- Since then, two practical problems have arisen recurrently:
- Should laboratories be coaxed, often against their will, to use only P95 size on their comminution standards and controls?

When performing heterogeneity testing, i.e. model (1) calibration, or when establishing or optimising preparation protocols and sampling nomograms, what if the P95 size is not available and no material left that can be screened (a typical situation when dealing with historic data)?

### Practical derivations of P95 to date

Going back briefly to Gy's purely experimental study of that constant  $g$ , Francois-Bongarcon established rules of thumb (ROT) to derive the likely P95 size when only another Pxx size is known. This was done by identifying a subset the typical curves, out of the well known 114 experimental used by Gy to relate the percent reject  $x$  (i.e. 100% -  $xx\%$ ) to the mass-weighted average volume of the fragments <sup>2</sup>. This subset was selected so as to represent the types of materials and comminution most often encountered in process plants and laboratories. These unpublished rules, which have been used as required but successfully since circa 2000, are shown on Table 1. They revealed a curiously arithmetic progression.

Table 1. ROT for P95 (circa 2000)

xx(%)	P95/Pxx
95	1.00
90	1.25
85	1.50
80	1.75

That left the problem of 'guesstimating' P95 when only P100 (a.k.a. Pmax or d-max) is known. Indeed it is not rare in protocols to prescribe crushing to a maximum size, which is usually achieved using a screen and iteratively returning its over-size to the crusher until all the material passes. It was in slightly more recent times that Francois-Bongarcon thought to have found a way to relate P95 to the maximum size.

Indeed, Gy had also published a curve (reproduced as Figure 1) that showed an alternative granulometric factor  $g'$  as a function of the ratio  $r=d\text{-max}/d\text{-min}$ . This new, rigorously demonstrated factor  $g'$  must be substituted to constant  $g$  in formula (1) in such a case, applying it to  $d\text{-max}^3$  instead of  $d^3$  (where  $d = d_{95} = P95$ ).

The study and mathematical formula that yielded that curve was not initially found. It was noticed by Francois-Bongarcon <sup>3</sup>, however, that the asymptote for very large ratios seemed to be close to 0.1. Assuming this was true, and observing uncalibrated material would correspond to an infinite value of the ratio  $r$ , to the limit, its  $gd_{95}^3$  would also be equal to  $g'd\text{-max}^3$  with a  $g'$  taken as the apparent asymptotic value of 0.1. Curiously again, this led to  $P95 = 0.75 d\text{-max}$ , which could hardly be another coincidence, so that a new table of ROT was used since then that included P100 (Table 2).

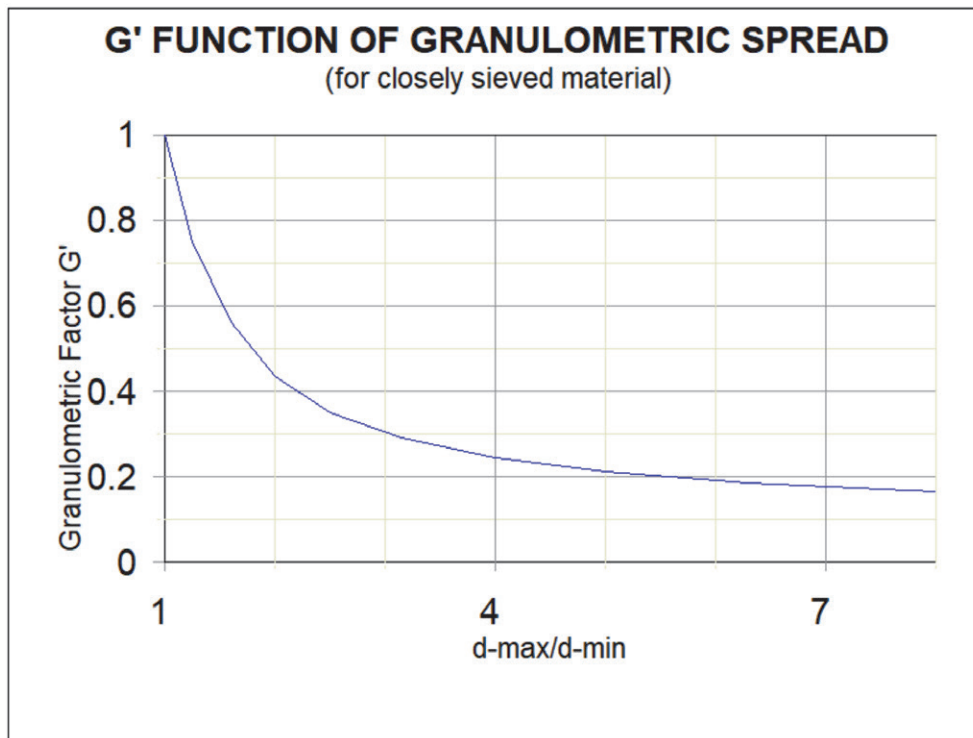

Figure 1. Granulometric factor for closely sieved material

Table 2. Revised ROT for P95 (published 2019)

Xx(%)	P95/Pxx
100	0.75
95	1.00
90	1.25
85	1.50
80	1.75

### Experimental fact checking

The time had come to (re-)verify these handy figures experimentally, especially the relationship to P100, as part of a series of papers being written on size distribution models.

After numerous discussions of the topic with the Intertek Laboratories in Jakarta, three usable data sets consisting of 10 samples each with detailed size distributions by screening were obtained. Two sets were for pulverized ore material, the third one was for crushed material. For each of the sets, it was possible to interpolate the Pxx for xx=5, 10, 15 and 20. A Rosin-Rammler model was used to improve the interpolations (over a linear one). For each sample of the crushed material, the maximum fragment size (P100) was evaluated based on screen retained masses by linear extrapolation, which was confirmed best over other methods, in the case of crushed material, using photos of the coarsest fragments. In each case, the P95/Pxx factors were calculated. The averages of these are shown in Table 3. They confirm the older ROTs, except for P95/P100, for which the new value of 0.40 is now recommended instead of 0.75.

This new, experimental confirmation of reasonableness the old ROTs for P90 and below make sense since they were already established based on Gy's experimental results. In retrospect, that the new experimental value of P95/P100 does not lie in the linear progression of the others makes sense. Cumulated size distribution curves have a stronger inflection/curvature somewhere above 95%, the strength of which, under the blinding charm of completeness of the observed linear progression, had been overlooked (Figure 2 – with any x-scale and/or units).

**Table 3. P95/Pxx Factors and ROTs**

	p95/pmax	p95/p95	p95/P90	p95/p85	p95/p80
<b>Crushed</b>	0.47	1.00	1.33	1.73	2.05
<b>Pulps</b>	0.42	1.00	1.27	1.47	1.72
<b>pulps(2)</b>	0.36	1.00	1.20	1.37	1.50
<b>AVG</b>	0.42	1.00	1.27	1.52	1.76
<b>Min</b>	0.26	-	1.11	1.20	1.33
<b>Max</b>	0.64	-	1.74	2.10	2.55
<b>Initial RoT</b>	0.75	1.00	1.25	1.50	1.75
<b>New RoT</b>	0.40	1.00	1.25	1.50	1.75

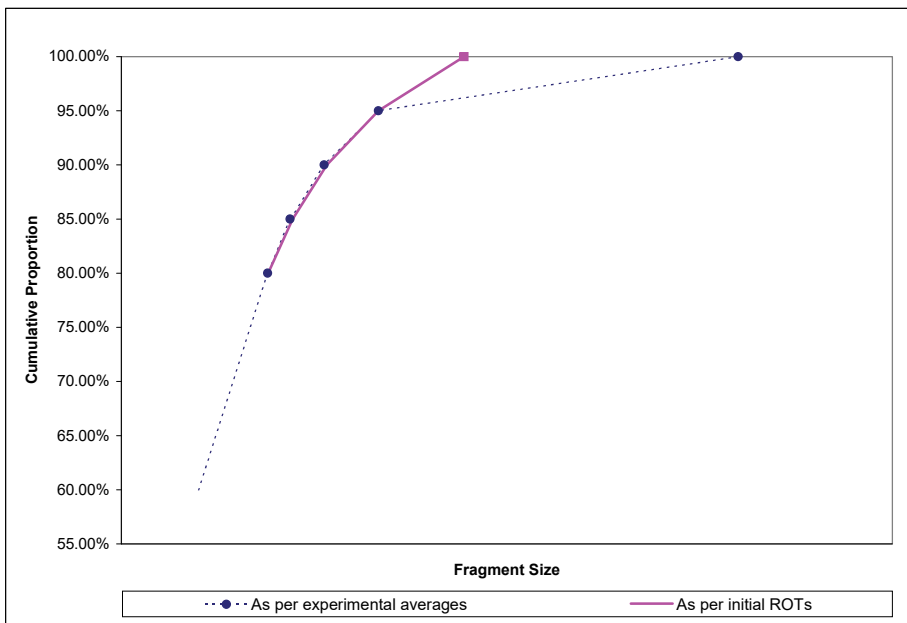

**Figure 2. Average Size Distribution of the Material**

### Closely sieved material

The curve of Figure 1 above was derived from a formula found in section 55.4.2 of Gy, 1967<sup>2</sup>, where the complete study of the g' substitute to the classical granulometric factor g is described.

Gy started off assuming that material was sieved between two screens of mesh  $d_0$  (=d-max) and  $d_R$  (=d-min), separated by a number 'R' of AFNOR standard screens sizes, or 'modules'. The AFNOR (French National Standardisation Organisation) screen sizes are in geometric progression of ratio  $10^{1/10}$  which is very close to  $2^{1/3}$ , so that:

$$d_R^3 = d_0^3 / 2^R \quad (2)$$

He then set up to estimating the average mass-weighted volume of the calibrated fragments between the two screens. Assuming approximately uniform distribution of masses in throughout the R modules, he found that the average cubed fragment in the calibrated material could be written  $g'd_0^3$  where:

$$g' = (1.5 - 1/2^{R-1} + 1/2^{R+1}) / R$$

If we call r the ratio d-max/d-min =  $d_0 / d_R$ , by virtue of (2),

$$R = 3 \text{LN}(r) / \text{LN}(2)$$

which allows us to adequately calculate g' from r, as on Figure 1, independently for the AFNOR progression.

As it turns out, the asymptote of that curve, however slowly reached, therefore is zero. This clearly invalidates any previous asymptotic reasoning to derive P95 from P100, which explains the wrong ROT for P100 that had been previously found.

## Conclusion

The experiment described in this paper is leading to the following take-away, but one should remember that deriving a P95 using ROTs remains a last resort when direct measurements are not possible:

- Previous ROTs below P95 were confirmed
- The ROT concerning P100 was found to be erroneous and was corrected
- The New ROTs in Table 3 are now believed to be safe to use

In particular, given the natural variability of comminution results from sample to sample, it may not be necessary to force laboratories to change their definitions of comminution standards and controls, as long as sampling calculations and nom-ograms are always made using P95 equivalents derived with these ROTs. This important conclusion is novelty.

## References

1. Francois-Bongarcon, 1998. Extensions to the Demonstration of Gy's Formula. in Proceedings CIM/CMMI/MIGA Montreal'98 Conference.
2. Gy, P.M. 1967. L'Echantillonnage des Minerais en Vrac, Tome 1. in Mémoires du BRGM, No. 56. Editions BRGM. Paris. 189.
3. Francois-Bongarcon, D. 2019. The Liberation Factor And Other Parameters: Are we at the end of the journey? in Proceedings Ninth World Conference on Sampling and Blending, Beijing.

## The sampling interface—A critical Theory of Sampling success factor in process sampling and PAT

K.H. Esbensen<sup>a</sup> and V. Sivalingam<sup>b</sup>

<sup>a</sup>KHE Consulting, Copenhagen, Denmark. E-mail: [khe.consult@gmail.com](mailto:khe.consult@gmail.com)

<sup>b</sup>Dept. of Process, Technology, University of South-Eastern Norway, Porsgrunn, Norway

**In the process industry arena, analytical endeavors are today well served by the Process Analytical Technology (PAT) framework, offering a plentitude of on-line analytics, mostly spectroscopic: UV-VIS, NIR, RAMAN, NMR, ‘acoustic chemometrics’ a.o. This context is generally considered satisfactory, but there is a major catch. The present paper focuses on a fundamental feature in process sampling, the *link* between an on-line analytical technique and a moving stream of matter, which is to be characterized, monitored, and analysed. A process sampling operation can serve many objectives; process regulation, product or interim product characterisation, optimisation of raw material consumption, maximizing energy efficiency, pollution, and environmental impact management – or process, plant, company, corporation decision making at supervisor and management levels concerning economics and risk management. All these objectives can only be meaningfully undertaken if based on *relevant information*, that is, if based on *reliable analytical data*, which in turn is 100% dependent upon *representative samples*, or *representative sensor signals*. The singular common element in all of this is the *process sampling interface*. This paper develops a critique of most current interfaces, with a scathing verdict: the dual role of the process sampling interface as both delineating an appropriate aliquot volume while facilitating the specific analytical technique, has largely been overlooked, with a significant negative effect that is spelled out in full detail across implemented solutions across widely different application sectors. Most current process sampling interfaces do not comply with TOS’ demands, putting representativity severely at risk for heterogenous materials.**

### Introduction – setting the scene

The Theory of Sampling (TOS) has always been front and center concerning **how to** extract representative samples from moving lots (process sampling), e.g. from a conveyor belt or from ducted material streams. TOS’ preeminence is that identical Governing Principles (GP), Sampling Unit Operations (SUO) and Sampling Error Management (SEM) can be applied identically to both stationary and to moving lots. The 70-year application history in TOS’ traditional realms is highly successful regarding physical extraction of increments and samples, especially in the Mining, Minerals and Metals processing and refining industry (M3), in cement production and in many other process industry sectors dealing with broken ores, particulate matter, minerals and slurries. A comprehensive, up-to-date introduction to TOS in these sectors can be found in three recent TOS textbooks, and in the wealth of references to the extensive literature found herein<sup>1-3</sup>. These are conveniently presented in a comparative overview, easily available<sup>4</sup>.

Recently in these industry sectors, a pronounced interest can be observed for applying modern *sensor technologies* for on-line monitoring because of the obvious advantages for fast, real-time information used for process monitoring and control allowing optimized decision making, all with significantly added economic results. These approaches take a broader view on available analytical techniques that can be applied on-line, always closely related to the characteristics of the materials and lots involved (physical, chemical, other). A key example outside TOS’ traditional realm is the use of Near InfraRed (NIR) spectroscopy in the broad pharmaceutical manufacturing context (‘pharma’ for short). In terms of societal importance and total turnaround economy, one can meaningfully equate M3 and pharma.

In the process industry arena today, analytical endeavors are well served by the Process Analytical Technology (PAT) framework, offering a plentitude of on-line mostly spectroscopic analytics: UV-VIS, NIR, RAMAN, NMR, ‘acoustic chemometrics’ a.o. A comprehensive introduction to this field can be found in the “PAT bible (2010)”<sup>5</sup>.

The present paper focuses on the fundamental feature in common in process sampling, the *link* between an on-line analytical technique and the moving stream of matter, which is to be characterized, monitored, and analysed. A process sampling operation can serve many objectives, process regulation, product or interim product characterization, optimization of raw material consumption, maximizing energy efficiency, pollution, and environmental impact management – or process, plant, company, corporation decision making at supervisor and management levels concerning economics and risk management. All these objectives can only be meaningfully undertaken if based on *relevant information*, that is if based on *reliable analytical data*, which in turn is 100% dependent upon *representative samples*, or *representative sensor signals* from the start.

The singular common element in all of this is – the *process sampling interface*.

Below it is shown that this commonality is the critical success factor w.r.t. representative sampling *sensu* TOS. To reveal the critical role of the process sampling interface, examples shall be presented from TOS' traditional realm (not many are needed taking into account the WCSB10 context), but deliberately also from what at first sight may appear as very different industrial sectors, pharma and *similar* industries (food/ feed processing, production and manufacturing for example), but which are never-the-less dealing with the same matter, i.e. heterogeneous aggregate mixtures, only often from a finer grain-size realm (powders, slurries). From these industrial sectors focus shall be on NIR spectroscopic applications, which are all in the realm of PAT.

While at first sight the M3 and pharma/food/feed (PFF) industry sectors are likely to be found disparate in the extreme in their process technology contexts and w.r.t. the wildly different materials involved, it turns out they are closely related in their *identical need* for representative process sampling to conduct reliable process monitoring and process control, and QC/QA of interim/finished product. In fact, for PFF the need for appropriate sampling Quality Management (QM) is *identical* to those for M3. This means that M3 and PFF industries are fully aligned and joined precisely at the juncture which is the focus for the present paper – the *process sampling interface*. The common *role* of the process sampling interface is to bring a specific on-line analytical technique in appropriate contact with the material/product/streaming material that is to be characterized. The role of the process sampling interface is to facilitate the analytic *interaction* with the moving material – without giving rise to sampling errors to any degree more than absolute necessary. This turns out to be a formidable challenge.

In this paper, the analytical specifics in themselves are not of interest (see the abundant PAT literature). Below it is all, and only about what comes *before* analysis. Also, the analytical competence *per se* is very rarely an issue; it is almost universally well taken care of in the form of thoroughly validated analytical procedures.

So, are the M3, PFF, and all similar particulate matter realms fully competent regarding the specific process sampling issues? After all, solutions to this task can look at the unparallel success for historical TOS applications over ~70 years in science, technology, industry, trade, society and in the environmental sciences. For more than five decades the Theory of Sampling (TOS) is rightly famous as the framework that covers all necessary elements, i.e. design of sampling procedures and equipment, correct implementation, correct practical operation, sufficient maintenance, a necessary and sufficient theoretical competence framework.

Well, it turns out there are still aspects of TOS application that can benefit from a general perspective - and none more so than the *process sampling interface*.

## TOS vs. PAT – an exemplar contrast from which to learn

Within TOS' traditional realms it is well known **how to** sample particulate matter and mixtures, both from stationary lots and from moving streams of matter. When it comes to **how to** extract physical increments and samples in a representative fashion, the foundation of TOS reigns supreme, and all new applications always take their point of departure from this framework and the from the wealth of accumulated practical experience, as witnessed by the historical library of Proceedings from the World Conferences on Sampling and Blending WCSB1-WCSB10. Sampling by physical extraction is very well served indeed, see<sup>6-9</sup> for example.

By contrast, for 'sensor sampling' i.e., Process Analytical Technologies (PAT), which is *claimed* to be a 'no sampling needed' approach, there is no similar theoretical framework for the sampling step, which is rather often treated in a somewhat stepmotherly fashion. Instead, a pronounced practical approach rules in this realm<sup>5</sup>, in which the question of **how to** achieve representative sensor signals is the first item on any agenda, here intimately related to the design and implementation of the specific analytical instrumentation, which is to be put in operation by way of a *sensor interface* connecting to, and interacting with, the streaming flux of matter.

This endeavor is closely related to the specific analytical technique involved (the use of NIR is dominant, but other analytical techniques find their use as well in specific cases). This is always based on specific *calibration* approaches; calibration is always needed as PAT instrumentation is multi-channel, multi-wavelength – producing *multivariate spectral data*. There can be observed a drive: "get the multivariate spectral signals – and all will be well", which is based on the overwhelming success of the data analytical discipline *chemometrics* in the form of *multivariate calibration* of process sensor signals from multi-channel analytical instruments<sup>10</sup>. One often gets the distinct impression that the specifics of a PAT sensor interface is more driven by the needs and requirements of the sensor analytics than of considerations for the analytical support (volume/mass) that can be realized. This is where the issue of the effective *increment volume* crops up.

Preluding what is more fully illustrated in systematic graphics below, PAT solutions make use of three principal types of interfaces, three sampling *modi*, which are very well known in TOS. Pat interfaces are almost always of the type (1,2) *instead* of (3):

1. Taking part of the stream, all of the time; *or*
2. Taking part of the stream, part of the time; *instead of*
3. Taking full cross-stream increments part of the time (the only TOS-compliant sampling approach)

These sampling *modi* have been illustrated with particularly clear graphics in a companion contribution in these proceedings, see Figs. 2-4 in Novaes & Hidding (2022)<sup>11</sup>.

With modus (3), focus rightly is on sampling the entire stream, *full slices* of the stream, while sampling *in process time*. While with (1,2), the full width/breadth/depth of the stream is never covered in full, leading to TOS-incorrect sampling, massive IDE, thereby breaking one the two necessary-and-sufficient requirements for representative process sampling (*unbiasedness* and *sufficient* precision).

Based on such a failing PAT focus, the issue of representativity here is mostly, or sometimes wholly, only related to spectral and reference sample measurement uncertainty (MU) – but data modeling errors and uncertainties are also acknowledged if the chemometrics is not up to the job (data model under – or over fitting). With this PAT focus, the realm ‘before sensor signal acquisition’ is often unwittingly ignored, even though this is the very domain where *sampling* errors abound. This issue constitutes the central theme of this presentation: In the PAT realm sampling errors are incurred in the exact *same fashion* as when extracting physical samples from moving streams. In the PAT realm this is largely a surprising insight – indeed this parallel is also able to shed light on how process sampling sometimes is subpar, even in the TOS arena.

For these reasons, sampling error effects impacting on the quality of sensor and probe signals largely constitute a *terra incognita* in the PAT realm. This situation invites all parties to take a serious look at the need to comply with TOS’ stipulations for representativity, no matter with what interface configuration sampling is performed. It turns out that there is a complete *duality* between TOS and PAT, which must be acknowledged and followed where- and whenever the goal is representative sensor signals, see chapter three in<sup>5</sup>, and also<sup>10,11</sup>. This duality is the central theme for this paper.

Be aware that a dear friend goes under many names. Thus, what in chemometrics is termed ‘*multivariate*’ (multi-variate, meaning *many variables*), in many other scientific and technological fields has acquired the name ‘*hyper-spectral*’ a.o. A good example of the latter, and a good example of the emerging awareness of the spectral (multivariate, hyper-spectral) advantage by frontline players, would be Mittrup et al (2017)<sup>12</sup>, which is also among the pioneers applying NIR spectroscopy in M3.

The contradiction between TOS and PAT has been highly frustrating, indeed a situation that has lasted for the better part of the last 10-15 years. The scope can best be illustrated by the fact that the first edition of the famed source book: “Process Analytical Technologies (PAT)” (2007) did not contain a specific chapter on sampling (*sic*). While the second edition, out just three years later (2010)<sup>5</sup>, features a comprehensive chapter, aptly named: “Process sampling: Theory of Sampling (TOS) – the missing link in Process Analytical Technologies (PAT)” – the title says it all!

## Focusing

In many industry sectors, there is today an emerging rush to take advantage of ‘modern sensor technology’ (including ‘advanced’ statistics, machine learning and other artificial intelligence approaches), to provide real-time process information to support and optimise business decision making. Although this trend manifests itself slightly differently in different process industry sectors, typically because the sector viewpoint is intimately related to one dominating specific analytical approach, e.g., XRF, PGNA, NIR, it is rare to find awareness of the overarching *hidden* commonality involved, the role of process sampling interface. Focusing on this issue makes it possible to review and critique a multitude of current applications to avoid making the same mistakes over and over in many disparate realms in science, technology, industry, trade, society, and the environment.

## In medias res - PAT

Process monitoring and control in technology and industry is *incomplete* without full understanding of all sources of variation, causing bias and impression. It is particularly important to be able to *decouple* sampling and analytical variations caused by bias-generating errors because these can, and shall be reduced maximally, indeed preferentially eliminated. This is the first, well-known mandate of TOS: elimination of sampling bias. By contrast, the analytical bias is fundamentally different, not always clearly acknowledged as is a major point in<sup>1</sup>. The analytical bias is treated very well within the specific analytical realm and literature.

A case in point: It is not enough to make use of Multivariate Statistical Process Control (MSPC) or similar QC/QAM monitoring approaches based on charted analytical results, because these may well be compromised by *unknown* significant sampling errors, if not adequately identified, quantified, and reduced to below a relevant *a priori* acceptance threshold: This situation results in unnecessarily large bias and impression.



More precisely: Process data are affected both by analytical measurement errors as well as extraction sampling errors or sensor signal acquisition errors. This understanding is of critical importance, because the latter two categories of sampling error effects are all too often unrecognized, or unknown. But worse, they typically dominate over analytical errors by factors 5-10-20+ the more heterogeneous materials targeted and/or if proper sampling competence is not brought to bear in the design, implementation, maintenance, and operation of the *total* process measurement system. Alarming, almost always the Total Analytical Errors (TAE) constitute only a very small, sometimes vanishingly small proportion of the total Measurement Uncertainty (MU) – What makes “all the difference” quantitatively and qualitatively, is the Total Sampling Error (TSE). Below we are only interested in **how to** minimize TSE in process sampling.

In the PAT and in the process technology context in general, it is not sufficiently known that sensor signal acquisition gives rise to *identical error types* as does physical sample extraction.

Below we bring forth the critical analogy between Process Analytical Technologies (PAT) and conventional physical sample extraction and show how three QCQAQM tools, the Replication Experiment (RE), interleaved sampling (IS), and variographic process characterisation (VC) can be involved. RE, IS, VC constitute a necessary and sufficient on-line approach for total variability decomposition. Without proper sampling error management (error *identification*, *reduction* and *elimination*), on-line analytical instrument calibration and validation will unavoidably incorporate significantly inflated data uncertainties, the bias complement of which is inconstant and without correction possibilities, all of which assuredly compromises the ultimate process monitoring and control objectives significantly.

The presentation below reflects the close interaction between TOS, PAT and chemometrics, a competence overlapping that is not much in focus in the IPGSA realm. Here, space consideration does not allow more than referral to a select suite of key, comprehensive literature sources for interested parties who wish to go deeper with respect to fundamental theory with all three scientific fields<sup>1,5-10</sup>.

A practical starting platform for the present objective shall be a fundamental sampling *duality*.

## The fundamental duality between physical and sensor sampling

Below all efforts have been made to make illustrations completely anonymous; no identification of persons, locations, instrument brand or companies is intended. Only the didactic value of correct vs. incorrect, faulty, or fatal non-compliance with TOS is of interest.

A fundamental sampling duality: Physical increment/sample extraction vs. sensor signal acquisition (PAT)

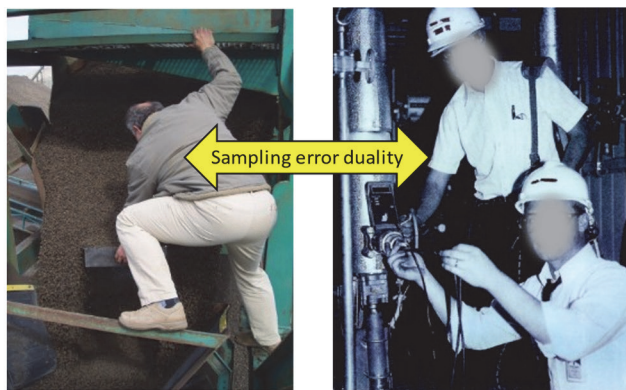

TOS: Identical sampling errors with , as without sensor technologies (PAT)

**Fig. 1. The fundamental sampling duality between physical increment/sample extraction (left) and sensor signal acquisition (right). Installing PAT sensors has often been claimed to be equivalent to ‘no sampling needed’ – alas! Illustration copyright KHE Consulting teaching collection, used with permission.**

Installing PAT sensors has often been claimed to be equivalent to ‘no sampling needed’ – alas, this is a complete fallacy. The issues treated below are not novelties for the sampling community – rather they should be trivial but are not entirely. But the main thrust of this paper is directed at related scientific communities, such as chemometrics, process technology, process engineering, processing, and manufacturing plant design – all facing the same issues. For these communities, it has been a rude awakening how the “Eureka moment” in the right panel of Fig. 1. dissolved into a whimper as soon as proper Total Measurement Uncertainty and full system performance validation was invoked. Alas, TSE error effects also abound in the PAT sensor world. “Why - there is literally no physical sampling involved?”

First lesson: Both physical extraction sampling errors and sensor technology spectral acquisition errors are in play – in fact they are identical, as even rudimentary TOS-analysis will show.

## The sampling interface

Figure 2 shows the key insight presented in this paper: TOS' mandatory rules that guarantee representative increment extraction from a moving lot (physical process sampling) are *identical* when applied to secure a representative sensor signal from a ducted material stream (sensor or PAT process sampling). There is an often-overlooked subtlety involved here, which is the distinction between a sample container, holder, cup, vial – and a *sampling interface*, see further below.

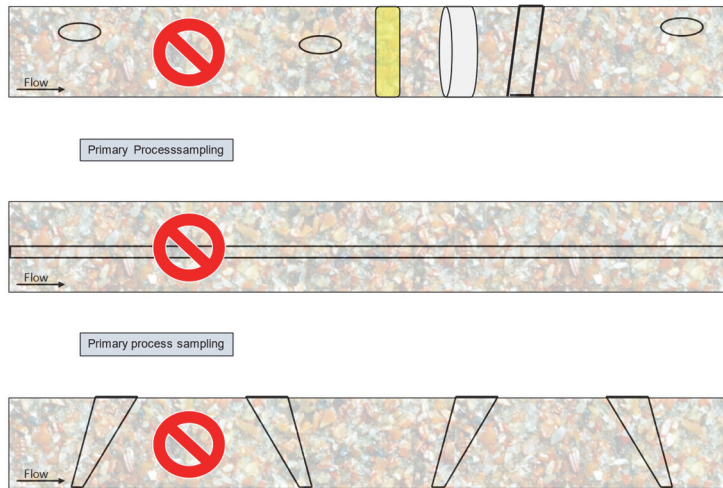

**Fig. 2. Key commonality between physical increment/sample volume and sensor signal support in process sampling: Identical rules apply w.r.t. correct increment delineation and extraction (complete and undisturbed volumetric coverage) for both physical extraction as well as for delineation of the sensor signal support volume as facilitated by a sampling interface. This illustration can either be viewed as looking down on a heterogeneous 1-D moving material lot f.ex. on a conveyor belt - or it can be understood as a vertical section through a horizontal conduit transporting a heterogeneous material (indicated by irregular texture). From both points of view, TOS-correct process sampling necessitates recovery of, or spectral coverage of, the full delineated cross-stream increment volume, shown by the three renditions in the upper panel Only fully covering increment volumes with planar-parallel boundaries will result in representative increments or samples. Illustration copyright KHE Consulting teaching collection, used with permission.**

Note the non-representative increment geometries indicated in Fig. 2. The upper panel shows fatal 'grab sampling', either as partial 3-D volumes or as superficial grabbed increments from the top of conveyed material only. The central panel illustrates increment delineation/extraction f.ex. resulting from a valve opening capturing a "partial fraction of the moving stream of matter all the time" only (as well exemplified by the infamous Shark Fin valve), while the bottom panel shows flawed cross-stream increment delineations, flawed as they furnish unbalanced increments w.r.t. transverse stream heterogeneity. None of these configurations corresponds to the imperative demand for an uncompromised full slice of the moving stream, none of these deliver TOS-compliant increments.

Thus, Fig.2 shows the non-negotiable demands for correct vs. incorrect increment delineation, which determines whether a sampling process will give rise to Increment Delineation Error (IDE) effects, or not. By implication, the illustration also shows the demands for elimination of Increment Extraction Errors (IEE). These demands on a practical physical sampling system, for example from a conveyor belt, applies with equal criticality for *sensor sampling*, but contrary to what is often *assumed*, there is not a dichotomous divide between physical – and sensor sampling. Fig. 3 shows the most often occurring principal process sampling options of either modality; it is noteworthy that all the shown examples from current process technology do not deliver representativity<sup>1-5</sup>.

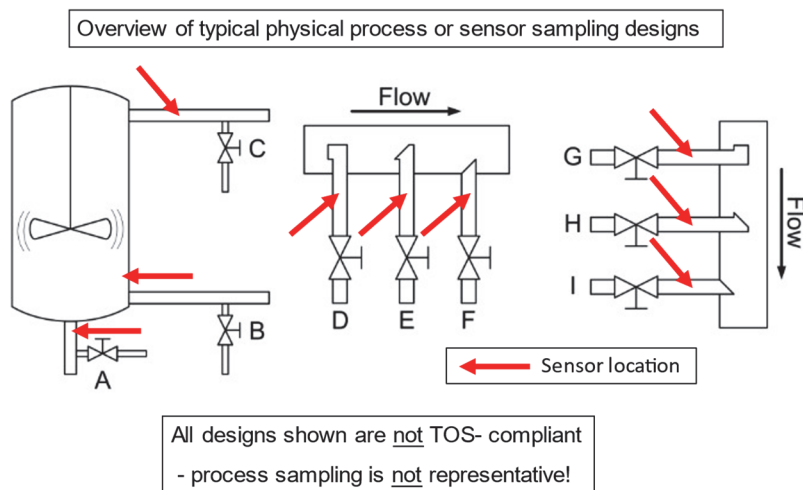

**Fig.3. Overview of typical, often occurring sampling system configurations and locations encountered in process technology across diverse industry sectors. “Sampling valves” are designated A through I, while typical locations of sensor technology solutions (PAT) are marked as red arrows. None of the process system solutions shown here are representative however, see<sup>5</sup>. Illustration copyright KHE Consulting teaching collection, used with permission.**

Whether designed for physical increment/sample extraction by use of “sample valves” [A through I] from vessels and containers, horizontal or vertical pipelines – or designed to take advantage of the much claimed “no sampling necessary” sensor technology (PAT), *none* of the sampling systems depicted in Fig. 3 will give rise to representative samples or signals, which is easily verified by reference to the ‘full slice imperative’ shown in Fig. 2.

Figures 2 & 3 and the remarks above, lend full justification to the *duality* argument illustrated in Fig 1.

There is another duality presented below. Illustrative examples of the main message in this paper shall come, apparently willy-nilly, from both the pharma PAT/NIR world and from the traditional TOS process realm addressing M3 for example. This is deliberate, as it is meant to bring forth the universality of the discussion of the process sampling interface that follows.

But first a few reflections on sensor spectroscopic penetration depth, which are of key interest.

### Spectral penetration depth also matters

NIR analysis is influenced by how lots, samples, and smaller sub-samples are handled *before* the aliquot is presented to the analyser. An iconic author in the NIR field (P. Williams, 2001) listed ~30 sample-associated factors that affect the accuracy and precision of NIR analysis, but only gave indicative actions for how to avoid *some* of these and emphasized that: “*If [these] are not efficiently carried out, consistent and accurate NIR analysis is not possible, no matter how sophisticated the software.*”, (Williams quoted in<sup>13</sup>). We might here add: “... and regardless of the analytical competence”. This view is in complete agreement with the principles presented by TOS.

Thus, with respect to analytical errors and their effect (NIR and for almost any other analytical modality), in a specific sense it is all about what comes *before* analysis – because this is where the quality, relevance and validity of the subsequent analytical results originate! Disregard for this realm is like the original sin ...

One specific analytical issue can also be seen as impacting the sampling realm, which is of paramount importance for sensor process sampling. This concerns the effective spectroscopic *penetration depth*. We shall use NIR as an *exemplar* for many other spectroscopic techniques, although their individual penetration depths will vary, and can be widely different. However, the principal argument below is universal: penetration depth is a *bona fide* sampling issue, penetration depth uncertainty matters!

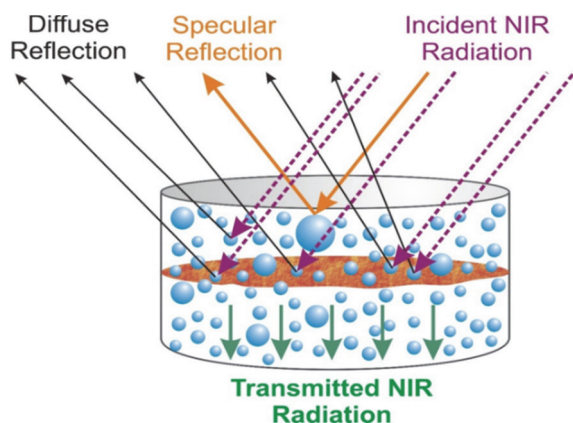

Fig. 4. Schematics for NIR spectroscopy/spectrometry, illustrating the thorny issue of varying penetration depth. Illustration copyright, Rodolfo Romanach teaching collection, used with permission. See also discussion in<sup>13</sup>

The analytical setup in Fig. 4 illustrates the business end of sensor sampling of a powder mixture, based on the interaction of the incident radiation with the material, either in an extracted sample contained in a sample holder (full cylinder height) or in an assumed, correctly delineated volume serving the same purpose as the sample container. This volume is delineated by the sensor sampling interface.

The key issue is that this interaction is simultaneously a sampling operation (sensor sampling), as well as the physical basis for quantitative analysis through a multivariate calibration model, allowing prediction of a specific material property (often a concentration) (Esbensen and Swarbrick 2018)<sup>10</sup>, Romaniach and Esbensen 2016)<sup>13</sup>. However, this type of chemometric prediction of analytical concentration will be fraught with unnecessarily inflated prediction errors (prediction variances), with varying material-dependent impacts, due to an obvious volume mismatch between the *assumed* aliquot volume (full cylinder height) and the physically realized support volume for the spectral signals, which is only a fraction thereof.

In this case, sensor sampling is intricately related to the physics of diffuse reflection in NIR spectroscopy. The volume mismatch issue is in general material dependent. As the top layers of the sample will receive more radiation than the bottom layers, less radiation reaches the bottom part of a material on a volume-to-volume comparison. For a given material with a specific physical constitution and different grain-size distribution a.o., the depth penetration also depends on the wavelength used. The lower wavelength radiation penetrates to greater depths at where molecules absorb less NIR radiations. Thus, the *effective sample mass* interacting with NIR radiation also *varies* according with wavelength. A more comprehensive introductory description of these issues can be found in<sup>13</sup> and in “Sampling” column in *Spectroscopy Europe/World SE-2* (2021)<sup>14</sup>, entitled “What are Sampling Errors – and WHAT can be done about them”, which has this ingress:

“The objective of this column is to provide easy-to-understand examples of sampling errors. Prompted by recent participations and presentations at on-line conferences and meetings, we believe there is a need for a more fulfilling introduction and exemplification of the concept and real-world consequences of committing “sampling errors”. WHAT is a sampling error? WHAT is the result of sampling errors? WHAT can we do about sampling errors? [...] The point of departure will be in the Theory of Sampling (TOS) and in the near infrared spectroscopy analysis and pharma application sectors, but the focus will be developed to be more *general*, so that readers can carry-over to other scientific and application areas of interest.”

The vast professional NIR literature is readily available (a plethora of references can be found in the literature referred to above).

The key issue is that the effective volumes are not identical – which according to TOS’ framework will unavoidably lead to a bias.

It is sometimes argued that since this mismatch error is ‘identical’ for all samples (calibration, validation, prediction samples), it will in effect create a ‘constant bias’, which will influence calibration, validation, and prediction samples identically, that can therefore be corrected for (as can an analytical bias). However, this is a fatal *misunderstanding* because this understanding tacitly *presupposed* that all materials, mixtures, and powders are *identical* when involved in NIR analysis, all differences in sample preparation, handling, pouring, compactification, and presentation a.o. notwithstanding. But this is clearly never the case for the multitude of very different materials subjected to NIR analysis in this world.

These relationships cannot be resolved universally by the traditional route of demanding a “bigger sample”. The solution is hoped to be NIR radiation interacting with an increased analytical mass in a well-designed fashion to accomplish practical *composite sampling* and at the same time guarantee sampling correctness (elimination of sampling bias). This objective has been the holy grail for decades of development of suitable ‘sample cells’ within the NIR realm, far from all of which having reached this goal, however. While the specific analytical problems of this kind are well recognised, it takes more

than a minimum of TOS competence to look through the immediate manifestations of many 'sample interfaces', salient examples appear below.

This kind of sensor sampling error cannot be corrected for by any physical pre- or post-treatment, any mathematical algorithm or by any software approach. These issues will always affect adversely on the possibility of developing fully optimised calibration models. All NIR spectroscopic methods are similar to a multiple path-length sample cell where particles may interact with radiation more times than once. The mass analysed by the radiation may be estimated in some cases but is generally not known in detail. Most other analytical chemists know exactly the material that is analysed, including its mass. The authoritative "HANDBOOK of NIR Analysis (2020)", chapter 19, characterises this fundamental sensor sampling enigma in the following way (*quote*): "NIR spectroscopists are spectacularly the most successful analytical chemists that do not know the exact sample mass being analysed!" Factor in the appropriate density of the analysed material, then mass = ~volume in this scathing dictum.

For multivariate calibration truly to be the chemometric be-all, end-all solution to process sampling, it is imperative that 'an increment – is an increment' - in the sense that 'a process sampling interface increment volume – is simultaneously also the physical reference sample volume of *matching size*'. This is obviously not something that can be taken for granted across the gamut of analytical techniques in the realm of PAT.

The process sampling interface is a harsh mistress at this most fundamental scale. It pays to pay attention, also because other issues occur at the scale of the process sampling interface itself.

## Spectral averaging is not composite sampling

Development of PAT systems to meet TOS' Fundamental Sampling Principle (FSP) is an ongoing challenge. Full compliance with FSP requires that an entire cross section of a process stream shall be obtainable for it to be a *bona fide* representative increment, Fig. 2. This requirement is probably the most often occurring sin-by-omission, or sin-by-neglect, in many current PAT and in similar process technological applications.

As but one example, the Field-of-View (FOV) of a beam of NIR irradiation only interacts with, say, the top 1-2 mm or so of a moving bed of matter. For a process stream the depth of which may be many, many times greater; there is clearly a massive Increment Delimitation Error (IDE) at work here. This situation must rightly be considered *beam grab sampling*, incurring a significant support volume mismatch. The parallel with physical grab sampling is striking – the duality is complete.

Today's dominating modus operandum is pledging allegiance to a massive averaging of spectral scans acquired during the process flow. While this in some, restricted way appears to constitute an improved procedure, the penetrative question is, how much better is a number of grab samples, scanned or physically obtained grabs, if none of them complies with the necessary principles for increment representativity? In the informed optics of TOS, this 'way out' for PAT analysts will unfortunately not necessarily lead to representative averaged signals even though *apparently* using spectral composite sampling - because it is still only the uppermost part of the streaming matter which is 'averaged'.

A representative composite sample (physical or optical) requires that all constituent parts of the lot moving through the sampling interface, have the *opportunity* to become part of the composite sample. This can manifestly not be obtained by any variation of increments which only represent the top of a moving stream, or any similar series of *partial* increment volumes only, Fig. 2. This is a structural impossibility. Spectral averaging is not by itself TOS-compliant composite sampling, thereby affecting TSE – but spectral averaging does help to get the analytical uncertainty better constrained, thereby affecting TAE (only). This all takes place under the complete boundary condition of the Total Measurement System Error  $TMSE := TSE + TAE$ .

## From PAT/NIR sensor sampling to physical sample extraction

What is the relationship between the pharma/NIR/PAT powder and powder mixture worlds briefly described above – and the traditional TOS realm of sampling of aggregated particulate materials of geological, biological a.o. origin over a very wide range of grain-sizes, say from decimeters to micrometers? Despite all the drastic intrinsic differences, from the point of view of process sampling *it is all the same* - only the scale changes.

## Key distinction

Perusing the relevant literature, one often comes across a misunderstanding concerning the distinction between a "sample cell" and a "sampling cell". The difference is very much not just a semantic difference – it constitutes the essential insight for full understanding of the role of the process sampling interface.

**A "sample cell"** (noun) (think of a sample holder, a sample cup, a sample vial, a 'petri dish' ... ...) *presupposes* that 'the sample' has been sampled before being put into this container. All the thorny issues regarding sampling have been left in the analytical ante-room, the realm 'before analysis'. For good order it is noted that this realm is typically comprised by

an integral series of sampling stages: primary -, secondary, tertiary sampling ... the last of which produces the analytical sample. The primary characteristic of a sample cell is that it is *passive*; it 'merely' is filled by the already-sampled analytical aliquot. "Someone else is responsible for the sampling" – heard this before?

A "sampling cell" (noun) is an *active* device that serves a dual purpose (think of a 'flow through' cell). A *sampling* cell is designed to delineate the operative volume support (sensor increment) from which spectroscopic signals is obtained, thus effectively determining the analytical sample mass - while simultaneously facilitating the spectroscopic interaction with the moving material (sensor field-of-view, analytical duct window opening a.o.). The former function has everything to do with TOS' concepts of IDE and IEE. A broader view is needed than the basic truism: all sampling cells enclose a specific volume, determined by the design of the sampling interface. Here is the most important distinction:

The dynamic analytical support volume delineated by the process sampling interface – must be equal to the volume of a 'full slice' increment, in the sense of Fig. 2. Indeed, physically it must be the *same volume*. No exceptions are acceptable, if representativity is the objective.

## Graphics – a picture tell a thousand words

The following figures are presented as principal sketches and generic renditions; they only serve the purpose of illustrating the characteristics of an installed process sampling interface. No identification of instrument brand, OEM, plant, company, corporation, or persons is intended. On the contrary every effort has been made only to present schematic didactic information pertaining to **how to** perform proper *process* sampling.

Figures 5-13 below all focus on the role of the sampling interface. The examples shown cover a wide and dominating range of contemporary process technological implementations and PAT installations.

It is highly significant that nearly all the illustrations are telling the story of **how not to** perform process sampling! The reason is sobering – there are not many practical process sampling equipment and system solutions found on the market today, or in contemporary industrial installations, that factually comply with TOS' requirements for representative process sampling. Unless the gamut of all the world's materials correspond to infinitely diluted chemical solutions or to perfectly mixed composite materials. Not many do (see also the compositional caveat below). For all of these, the following will be a dramatic eye-opener,

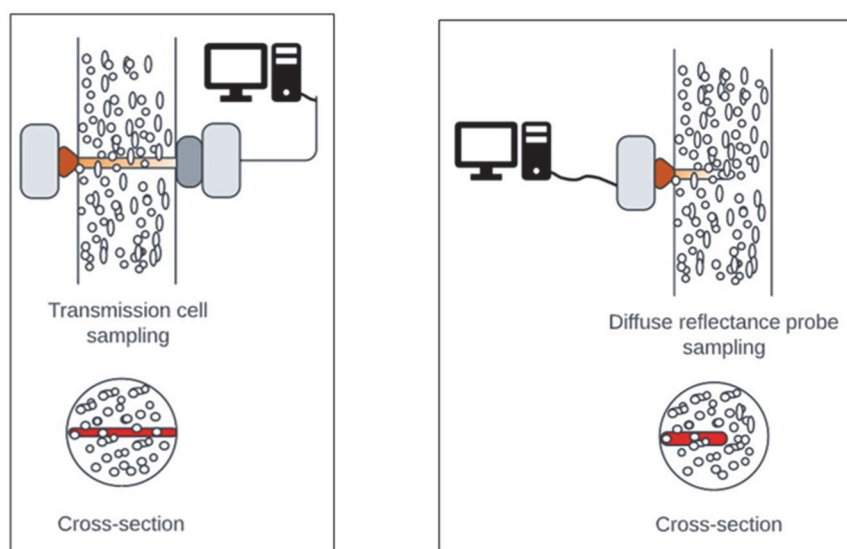

**Fig. 5. Principal sketch of process sampling interfaces for analytical techniques purporting to deliver sensor signals that are representative of the streaming matter in conveyed flows, ducted pipes or from reactors. The flow intersecting volumes, depicted in red in cross-section views of the flow, do not comply with the imperative demand for a full cross-sectional slice, cfr. Fig. 2. Illustration copyright KHE Consulting teaching collection, used with permission.**

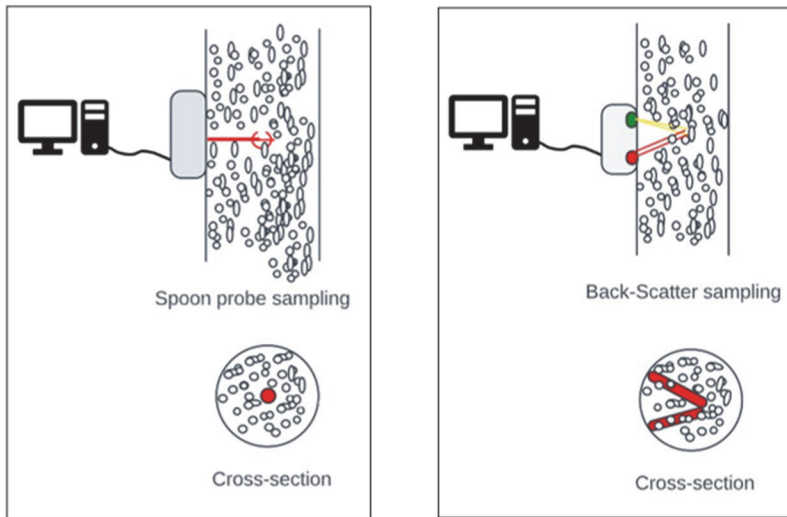

Fig. 6. Principal sketch of process sampling interfaces for analytical techniques purporting to deliver sensor signals that are representative of the streaming matter in conveyed flows, ducted pipes or from reactors. The flow intersecting volumes, depicted in red in cross-section views of the flow, do not comply with the imperative demand for a full cross-sectional slice, cfr. Fig. 2. Illustration copyright KHE Consulting teaching collection, used with permission.

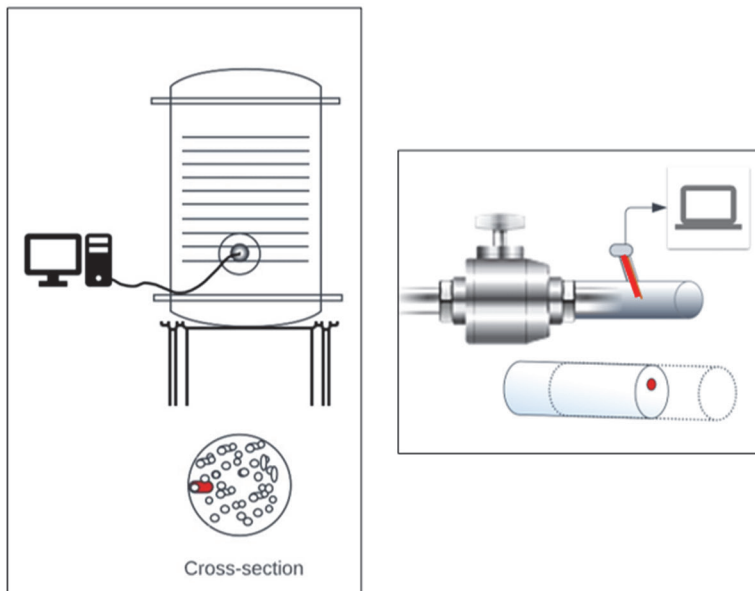

Fig. 7. Principal sketch of process sampling interfaces for analytical techniques purporting to deliver sensor signals that are representative of the streaming matter in conveyed flows, ducted pipes - or from reactors. The flow-intersecting volumes, depicted in red in cross-section views, do not correspond to the imperative demand for a full cross-sectional slice, cfr. Fig. 2. Illustration copyright KHE Consulting teaching collection, used with permission.

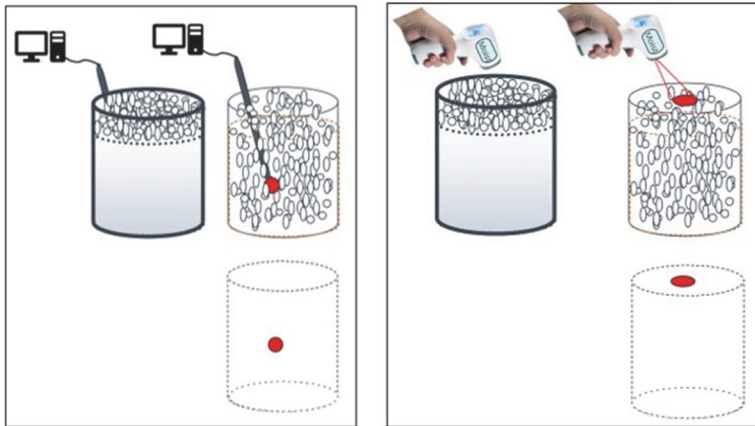

Fig. 8. Principal sketch of process sampling interfaces for analytical techniques purporting to deliver sensor signals that are representative of the lot material residing in storage containers and similar. The realized analytical support volumes, depicted in red in cross-section views, do not correspond to the imperative demand for a full cross-sectional slice, cfr. Fig. 2. A series of containers or drums, for example from a production line or forming an incoming raw product line, also constitute a process sampling situation, whether sampled by an installed sensor (left) or a handheld device (right). Illustration copyright KHE Consulting teaching collection, used with permission

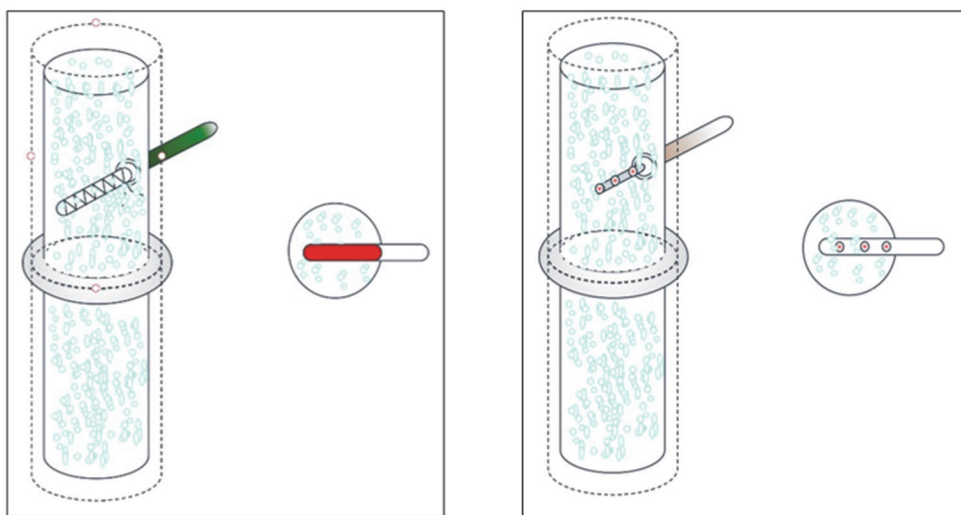
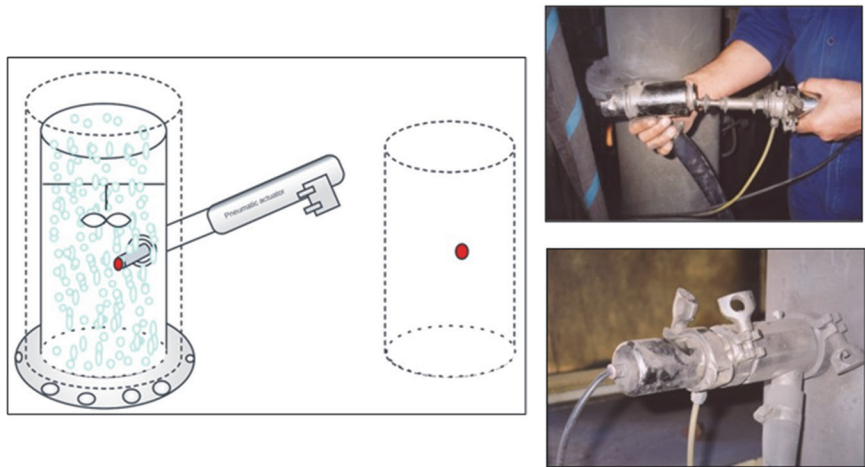
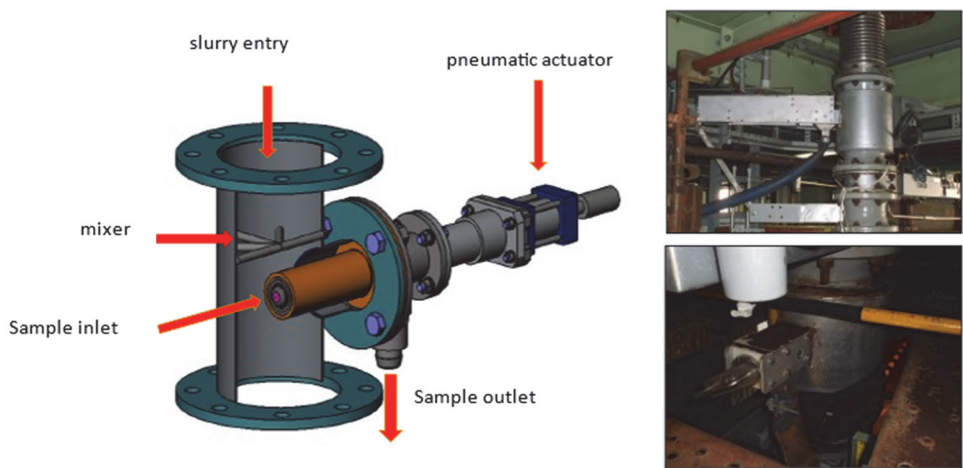

Fig. 9. Principal sketch of process sampling interfaces purporting to deliver physical increments that are representative of the streaming matter in conveyed flows, ducted pipes or from reactors. The realized analytical support volumes, depicted in red in cross-section views of the flow, do not correspond to the imperative demand for a full cross-sectional slice, cfr. Fig. 2. Inserting probes and screw samplers makes no difference, despite many claims to the contrary in the marketplace. The deliverable is a far cry away from a correct, full slice of the stream, cfr. Fig. 2. Illustration copyright KHE Consulting teaching collection, used with permission.





**Fig. 10. Principal sketch of process sampling interface purporting to deliver physical increments that are representative of the streaming matter in conveyed flows, ducted pipes or from reactors. The realized analytical support volume, depicted in red in cross-section views of the flow, do not correspond to the imperative demand for a full cross-sectional slice, cfr. Fig. 2. Process control samplers, including pressure pipe and poppet samplers, make no difference, despite many claims to the contrary in the marketplace. Illustration copyright KHE Consulting teaching collection, used with permission.**



**Fig. 11. Principal sketch of process sampling interfaces purporting to deliver physical increments that are representative of the streaming matter in conveyed flows, ducted pipes or from reactors. The realized analytical support volume (“sample inlet”) does not correspond to the imperative demand for a full cross-sectional slice, cfr. Fig. 2. Poppet samplers makes no difference, despite many claims to the contrary in the marketplace. Illustration copyright KHE Consulting teaching collection, used with permission.**



Fig. 12. Principal sketch of process sampling interface purporting to deliver physical increments that are representative of the streaming matter in conveyed flows and ducted pipes. The realized analytical support volume, here depicted in green in cross-section view of the flow, do not correspond to the imperative demand for a full cross-sectional slice, cfr. Fig. 2. This illustration shows the famous ‘shark fin’ sampler. It fails to extract a complete slice of the moving matter but delivers only a narrow central ‘part of the whole stream all of the time’. The cross-sectional areas indicated in red are structurally never available for sampling and will therefore never be able to comply with TOS’ Fundamental Sampling Principle (FSP) resulting in a highly significant sampling bias. Despite many claims in the marketplace, it is obvious that the shark fin sampler is not representative. Illustration copyright KHE Consulting teaching collection, used with permission.

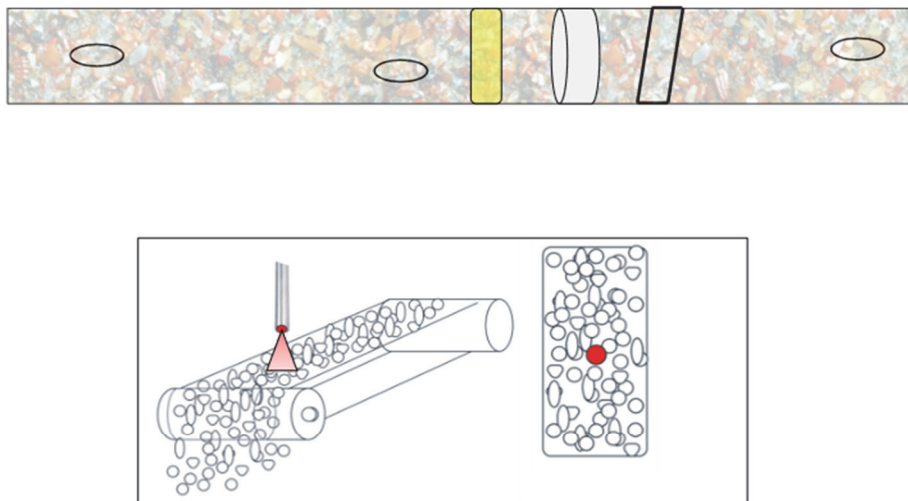
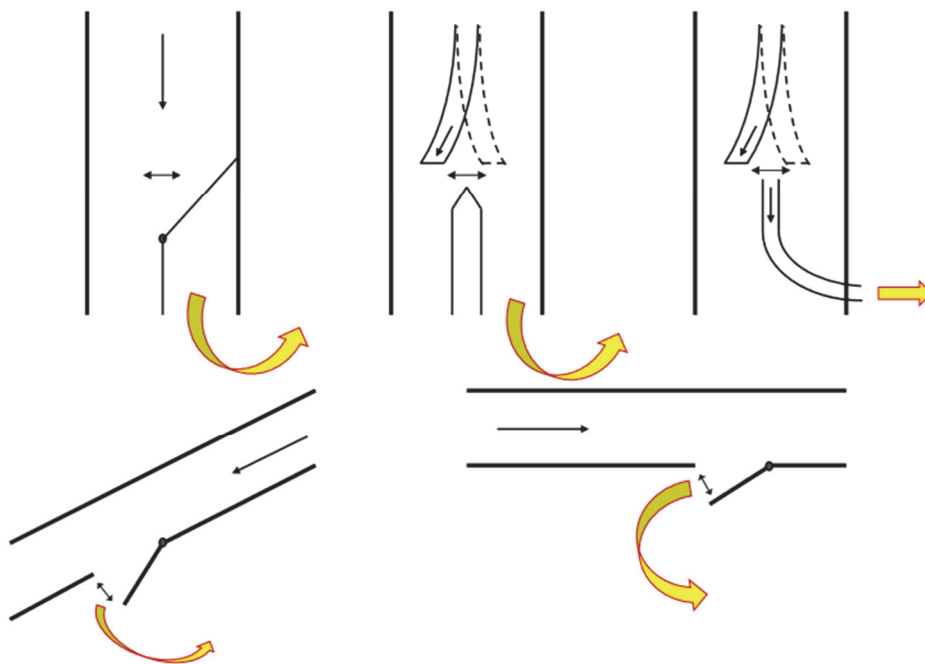

Fig. 13. Principal sketch of a process sampling interface purporting to deliver sensor signals that are representative of the streaming matter in conveyed flows. The realized analytical support volume (red) does not in any way correspond to the imperative demand for a full cross-sectional slice, cfr. Fig. 2. Many hopeful suggestions involve sensors, or cameras, capturing views (narrow-angle, or broad-angle) of moving streams of matters, which fall under the category process sampling. It is obvious however, that such solutions will always fail w.r.t. the imperative slice rule, at best delivering sensor grab samples. The duality with traditionally extracted physical grab samples from the top of the conveyed matter only is striking. Grab sampling is never a solution, neither in TOS’ domain, nor in the PAT sensor domain. Illustration copyright KHE Consulting teaching collection, used with permission.

## Underlying assumption of cross-sectional homogeneity

Upon reflection, all the non-representative exemplifications presented above, *would* to some degree be able to function – if only all instantaneous flow cross-sections *were* homogenous. This underlying *assumption* is widespread in very many process technology contexts where TOS literacy has not been obtained.

A warning, also part of the process sampling interface discussion, concerns the *by-pass valve*, often used to try to mass-reduce (sub-sample) a streaming flow of matter on the fly. While this objective is highly desirable, it is also very difficult to realise in practice, because of a fundamental misunderstanding. Not any by-pass valve follows TOS' demands for correct increment cutting. In fact, of the five alternatives shown in Fig. 14, only one is TOS compliant! Check out your next blueprint showing 'by-pass streams'. Exactly **how** is this by-pass diversion effectuated? There are many examples in which use is made of one of the non-compliant stream diversion options shown in Fig. 14, the effect of which can be of varying importance, but never neglectable. For full description, see<sup>2,5,13</sup>.



**Fig. 14. The by-pass valve enigma. How to divert a moving stream in a representative fashion? Of the five alternative designs for diverting a mass- and flow-reducing by-pass stream, only one is TOS-compliant (top rightmost example). Illustration from KHE Consulting teaching collection, used with permission.**

## A (very small) compositional caveat

To be fair, many of the process sampling system solutions depicted above actually do work according to their fundamental objectives of securing representative process samples – but this **only** applies to one-phase material systems, e.g. infinitely diluted solutions ('fluids') or mono-disperse particulate materials (uniform materials) a.o. in which there by definition are no compositional heterogeneity, no untoward grain-size distributions variability, and no grain size-grade heterogeneity issues.

Upon reflections, these latter constitute the overwhelmingly dominating proportion of the kind of materials treated with process sampling. Thus, the sampling difficulties illustrated in this paper concerns what in TOS parlance is known as 'significantly heterogeneous materials', which comprise the by far overwhelming proportion of materials targeted for process sampling and analysis in science, technology, industry, trade, commerce, environment ... and society.

An ongoing concern is that solutions devised for 'easy' chemical or physical systems have led to a various process sampling interfaces that do a fair job *within* their quite specific restricting limits, but only here. Great problems ensue when such system solutions unwittingly are being carried over to other types of materials of the significantly heterogeneous type – because here they are *bound* to fail, as the intrinsic heterogeneity of such systems (compositional heterogeneity (CH), distributional heterogeneity (DH), grain-size distribution heterogeneity and grain-size-grade heterogeneity obviously deviates from easy-to-sample 'uniform' material systems.

So, unfortunately, as a caveat, this one is very, very small and it cannot be used as justification for carrying-over of any process sampling solution from the 'easy' realm.

## How to gauge the performance of a process sampling solution?

All process system solutions, in which the sampling interface interacting with a specific moving material has not been previously characterized, must be subjected to a complete system's performance validation. It is necessary to validate all sampling systems for its status w.r.t. an a priori decided TSE variance threshold, which would qualify the sampling system as 'fit-for-purpose' representative, or not. There is no space here to go into detailed descriptions of the well-known quality assessment approaches just listed below; but full details can be found in very many references within the TOS realm. Suffice here to mention<sup>1-5</sup>.

Full system sampling performance facilities:

- Interleaved sampling (IS)
- Replication Experiment (RE)
- Variographic characterization (VC)

## So, what to do, then?

TOS calls for compliance validation of all existing designs not previously characterised and for innovative compliance in all future designs of process sampling interfaces. Validation in the view of the above presentations is of critical importance regarding representativity, especially concerning already installed systems that are "too expensive to fail". For all such cases, the key issue is simple: does the existing, or the newly designed sampling solution, capture the *entire* cross-section of flowing streams of matter in an *TOS-appropriate* manner, or not. It cannot be stated simpler ...

The hopeful quest for a universal process sampling interface will probably go on – regarding both sensor sampling and physical sample extraction. But is there a universal interface design? Whatever the answer to this question, TOS must serve as the guiding framework for all future developments with Fig. 2 outlining the principal, extremely simple, yet apparently so difficult demand: "Obey the slice rule – or representativity is lost". However, there is no other way!

## References

1. K.H. Esbensen, *Introduction to the Theory and Practice of Sampling*, IMPOpen, Chichester, UK. (2020).
2. F. F. Pitard, *Theory of Sampling and Sampling Practice* 3<sup>rd</sup> ed., CRC Press, Taylor & Francis Group, Boca Raton, FL. (2019).
3. G. J. Lyman, *Theory and Practice of Particulate Sampling an Engineering Approach*, Materials Sampling & Consultancy PTY LTD., Southport, Queensland, AUS. (2019).
4. TOS Forum. 10, [https://www.impopen.com/tosf-toc/20\\_10.IMPOpen](https://www.impopen.com/tosf-toc/20_10.IMPOpen), 15-19, IMPOpen, Chichester, UK. (2020).
5. K.A. Bakeev (Ed.) *Process Analytical Technology: Spectroscopic Tools and Implementation Strategies for the Chemical and Pharmaceutical Industries* 2<sup>nd</sup> ed., John Wiley & Sons, LTD., West Sussex, UK (2010).
6. K.H. Esbensen and P. Minkkinen (Eds.) Proceedings of the First World Conference and Sampling and Blending, Special Issue: 50 Years of Pierre Gy's Theory of Sampling, *Chemometrics and Intelligent Laboratory Systems*, **74:1**, Elsevier B.V., Oxford, UK. (2004)
7. K.H. Esbensen and C. Wagner (Eds.) *Proceedings for the 7<sup>th</sup> World Conference on Sampling and Blending*, in TOS forum, vol **5**, IMPOpen, Chichester, UK (2015).
8. S.C. Dominy and K.H. Esbensen (Eds.) *Proceedings of the 8<sup>th</sup> World Conference on Sampling and Blending*, AusIMM, Carlton Victoria, AUS. (2017).
9. BGRIMM Group (Eds.) *Proceedings for the 9<sup>th</sup> World Conference on Sampling and Blending*, BGRIMM Group, Beijing, China (2019).
10. K.H. Esbensen and B. Swarbrick, *Multivariate Data Analysis: An introduction to Multivariate Analysis, Process Analytical Technology and Quality by Design*, 6<sup>th</sup> edition, Camo Software A/S, Oslo, Norway (2018).
11. A.R. Novaes and B.M. Hidding, 'Choosing metallurgical samplers or static cutters for process control in slurry: when or why to avoid the increment delimitation error, in *Proceedings of the 10<sup>th</sup> World Conference on Sampling and Blending*. IMP Open, Chichester, UK, pp. 171–175 (2022).
12. D. Mittrup, O. Dominguez and M. Haest, "A new approach to implement quality assurance and quality control to technological innovations—quality of spectral data capture and processes in the minerals industry" in *Proceedings of the 8<sup>th</sup> World Conference on Sampling and Blending*, Ed. by S.C. Dominy and K.H. Esbensen, AusIMM, Carlton Victoria, AUS. (2017).
13. A.P. Ferreira, J.C. Menezes and M. Tobyn (Eds.) *Multivariate Analysis in The Pharmaceutical Industry*, Elsevier, Academic Press, London, UK (2018).
14. R.J. Romañach, A. Joubert Castro and K.H. Esbensen, "WHAT are sampling errors—and WHAT can we do about them? Part 1", *Spectrosc. Europe* **32(2)**, 36–42 (2021). <https://doi.org/10.1255/sew.2021.a11>



## Online elemental analysis for process control in the mineral processing industry

L. Rybok<sup>a\*</sup>, T. Kowoll<sup>a</sup>, A. Thomas<sup>a</sup>, A. Nad<sup>b</sup>, and C. Bachmann<sup>a</sup>

<sup>a</sup>J&C Bachmann GmbH, Pforzheim, Germany. E-mail: [lry.tko.ath.cbal@icbachmann.de](mailto:lry.tko.ath.cbal@icbachmann.de)

<sup>b</sup>Circular Economy Solutions, Geological Survey of Finland, Outokumpu, Finland. E-mail: [alona.nad@gtk.fi](mailto:alona.nad@gtk.fi)

Even though devices to perform online and inline elemental analysis are widely available, they are generally under-utilised in the mineral processing industry. Instead, information obtained from laboratory analysis of material samples is used for process control, despite of sample analysis being time-consuming, expensive and error prone. Thus, in this paper, we demonstrate that online elemental analysis is a viable alternative to sampling-based material monitoring. To this end, we present the results of field-studies performed in a controlled environment, as well as at a flotation cell of the GTK Mintec mineral processing pilot plant. In both studies, we analyse the copper concentration in a suspension using the FLORIDA XRF device and report relative errors as low as 4% under controlled conditions, and 6% at the processing plant.

### Introduction

Froth flotation<sup>6</sup> is one of the most common techniques in the mineral processing industry, during which the fine-grained minerals are separated by taking advantage of their hydrophobicity. To maximize target material yield, the process parameters need to be continuously optimized, which is typically achieved by manual sampling of the extracted material followed by laboratory analysis of the samples' chemical composition<sup>5</sup>. This method of process control is, however, very time-consuming, expensive, and error prone.

In this paper, we demonstrate the viability of inline and online elemental analysis as an alternative to the sampling-based approach for process control. Specifically, we evaluate the FLORIDA XRF analyser<sup>2</sup>, which adapts the X-ray fluorescence (XRF) principle to determine the elemental composition of slurries and suspensions without direct sampling. The device can be mounted directly on pipes at a mineral processing plant for reliable continuous monitoring of the concentration of chemical elements with an atomic number greater than 20. When used for process control, it has the advantage over sampling-based approaches, that it allows for an immediate response during process optimization while eliminating some errors arising from sampling.

It should be noted, however, that due to the underlying measurement principle, the analyser does not measure the elemental composition of the whole product stream, but only of a fraction thereof, and thus still suffers from some errors associated with sampling. For instance, we can only hope that turbulent flows cause the measured material to be sufficiently homogenized to result in representative samples. Thus, we do not claim, that online elemental analysis leads to more representative results than laboratory analysis of periodically extracted samples, but rather that it is a viable alternative.

To support this claim, we have conducted a field study on-site at a flotation cell of the GTK Mintec pilot plant<sup>1</sup> and in this paper we evaluate the performance of the inline elemental analyser for process optimization and compare the results with traditional sample analysis. For the study, copper ore slurries were prepared and pumped through a pipe segment installed



**Figure 1.** FLORIDA XRF analyser that has been installed at a flotation cell of the GTK Mintec plant for our experiments. The upper box of the device is the sensor head consisting of an X-ray tube, an SDD detector, and a cooling system. It is fed by the attached pipe. The lower box contains the control cabinet of the device.

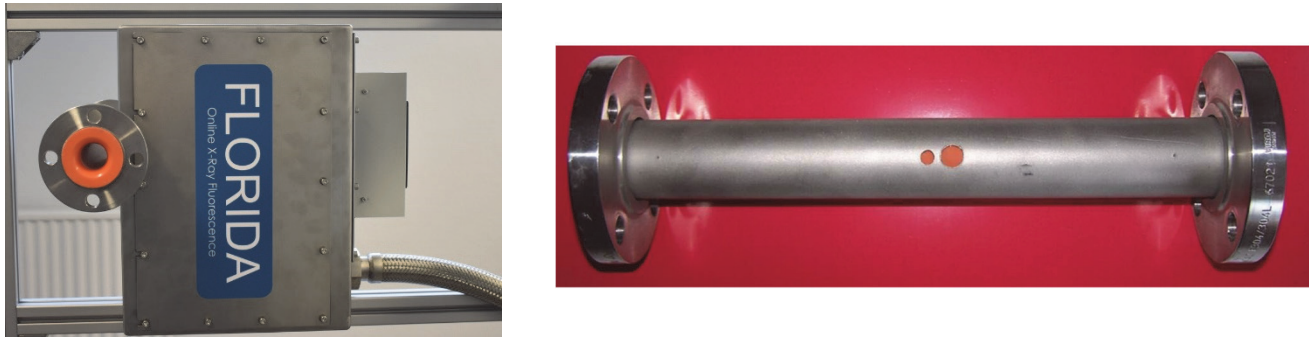

**Figure 2 Left: FLORIDA sensor with attached spool piece. Right: A typical 40 mm spool piece with a measuring window in its centre. To ensure that the pipe is always filled with slurry, it is ideally installed in a vertical position. If only a horizontal position is possible, the window should be placed in a 03:00 or 09:00 position to make sure that the slurry is measured instead of rising bubbles or settling sediments and thus increase the representativeness of the measurement.**

in the FLORIDA XRF device which continuously recorded XRF spectra of the slurry. Simultaneously, the device's outflow has been sampled for laboratory analysis of the slurry chemical composition. We compare these laboratory results with the measurements of FLORIDA and show a relative measurement error of 6%, which can mainly be attributed to sampling errors and statistical uncertainties that are inherent to XRF analysis.

We conclude the paper with a qualitative evaluation of a long-term measurement of the slurry during which the process parameters were altered several times and thus show that capability of online and inline elemental analysis to delineate trends that likely can be used for process control in the mineral processing industry.

### Online elemental analysis for process control in the mineral processing industry

The goal of process control in mineral processing is to optimise the recovery of valuable minerals, while maintaining the quality of the concentrates delivered to the processing plants<sup>5</sup>. After the minerals have been liberated from the ore by comminution and sizing processes, they are separated from the gangue using methods that depend on the materials' relative physical and surface chemical properties, such as hydrophobicity, specific gravity, magnetic susceptibility, and colour. This separation process is highly complex since it is influenced by a high number of parameters that require to be tuned to guarantee optimal yield.

To control the effect of the parameter adjustments, the quality of the concentrate needs to be constantly monitored. Typically, this monitoring is performed by sampling the material and analysing the samples in a chemical laboratory. This process is not only expensive but also time consuming, which has been shown to result in negative economic impacts<sup>7</sup>. Furthermore, any sampling process of heterogeneous materials generates errors which result in inaccuracies of the laboratory analysis<sup>4</sup>. According to Gy's Theory of Sampling (TOS)<sup>3, 4</sup>, these sampling errors can be divided into three main classes: errors that are caused by material heterogeneity, errors that are inherent to the sampling process, and analytical errors that are encountered during laboratory analysis of the samples. Note, that beside of the identification of sampling errors, TOS also provided tools for their evaluation, minimisation, and/or elimination; however, in practice the utilization of this toolset is still rare, despite TOS being a gold standard for many decades.

An alternative to sampling-based methods for process control are inline and online elemental analysers, which have the advantage of forgoing the error-prone manual material sampling step for offline analysis. Instead they offer immediate information about the process and can be continuously operated 24/7 for material monitoring. However, even though such devices are widely commercially available, they are generally under-utilised in the mineral processing industry due to the plant operators' distrust in the online information given by estimation models<sup>5</sup>. These devices are typically based on the X-

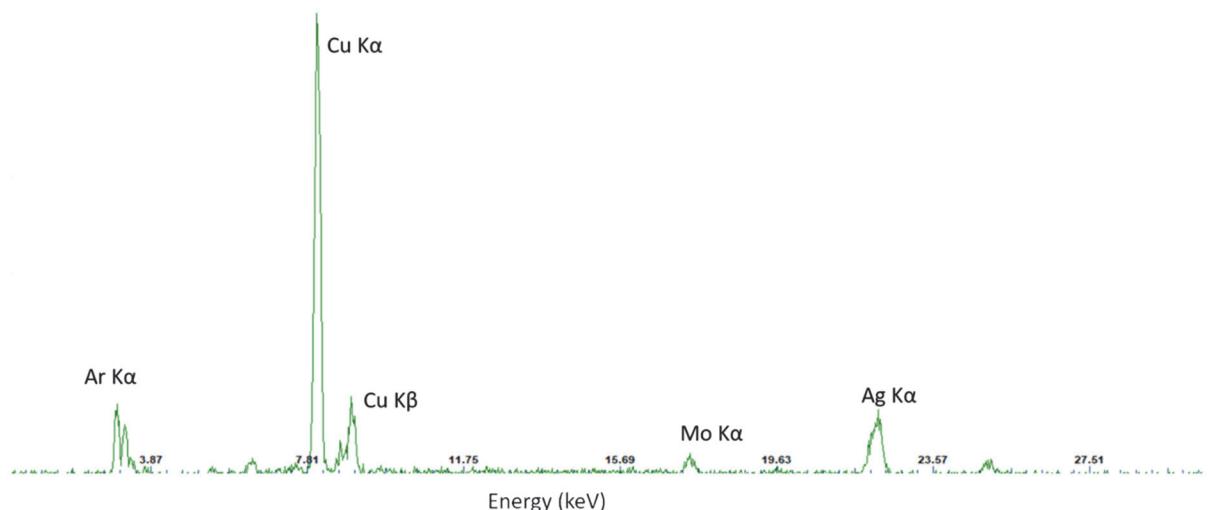

**Figure 3. Typical sample spectrum recorded with an XRF analyser, such as FLORIDA XRF.**

ray fluorescence principle or Prompt Gamma Neutron Activation Analysis (PGNAA). Among XRF-based devices are the Courier 5X/6X<sup>8</sup>, PERI Online Slurry Analysis System<sup>9</sup>, Boxray 24<sup>10</sup>, and FLORIDA XRF<sup>2</sup>, while the GS Omni<sup>11</sup> uses the PGNAA technique. While all the aforementioned devices are aimed at the online analysis of slurries and suspensions, similar solutions for the analysis of solids like coal or ores exist as well, such as the XRF-based CON-X<sup>13</sup> and TEXAS<sup>14</sup> analysers, and the PGNAA-based GEOSCAN<sup>12</sup> series.

### FLORIDA inline and online X-ray fluorescence analyser

The FLORIDA XRF analyser for liquids and slurries has been developed by J&C Bachmann GmbH and adapts the industry-proven X-ray fluorescence analysis used in chemical laboratories for plant conditions. The device enables continuous monitoring of the physical composition of the material in the process and can be installed directly on a process pipe, as shown in Figure 1. A dedicated spool section with an application-specific measurement window is installed (c.f., Figure 2). Spool and window are specified to meet the chemical and physical conditions and to protect the sensor system against damage. The systems do not require continuous or regular sampling for its calibration and can be used in a large variety of applications.

The XRF technique<sup>15</sup> relies on generation of fluorescent X-rays by bombarding a sample with high-intensity X-rays produced by an X-ray tube. The fluorescent X-ray photons are then detected by an energy discriminating detector. This detector further sorts the registered photons into one of a predefined number of channels and reports the particle counts in each channel as a spectrum (c.f., Figure 3 for an example XRF spectrum). The mapping between a channel and the photon energy is achieved by means of an energy calibration step with a defined sample of known composition.

Each chemical element produces a signal at its characteristic energies, which is represented as a peak in the spectrum. Thus, to quantify the concentration of the target element, first the area of its corresponding peak is determined which is then mapped to the elemental concentration by means of a calibration curve whose parameters are learned from a reference sample set with a known concentration, which is determined by a laboratory. Since the relationship between the areas of characteristic peaks and the elemental concentration is usually linear, in most cases, linear regression is used for the underlying calibration model, and any deviation from this linear curve (primarily due to absorption of emitted lines by other elements in the sample) can easily be corrected by influence coefficients or other methods.

### Elemental analysis for process control

To demonstrate the suitability of online elemental analysis as a viable alternative to laboratory analysis of periodically sampled produce, which is typically performed for process control in a mineral processing plant, we have conducted several measurements with the FLORIDA XRF analyser under varying environments. Specifically, we have conducted two measurement campaigns which will be discussed in detail in the following subsections. The first measurement campaign has been conducted in a controlled environment to establish a baseline that is independent of any errors introduced by the material sampling process, whereas the second one has been done at the GTK Mintec pilot plant. To increase comparability of the measurement campaigns, both campaigns performed under similar conditions, regarding the measurement parameters.

Throughout the experiments, we report as evaluation metric the mean absolute error (MAE) and the mean absolute percentage error (MAPE). In this context, the MAE is a measure of errors between the elemental concentration reported by a chemical laboratory and the FLORIDA XRF. When using online elemental analysers, this error typically increases with an increase of the target element concentration, which is caused by physical phenomena, such as absorption and scattering<sup>17</sup> of the radiation, in-homogeneity of the measured material, or other random fluctuations associated to the process of measurement of X-ray peak intensities<sup>16</sup>. Nonetheless, the MAPE being the relative deviation between both measurements is usually independent of the concentration, which is why it is reported as well. Furthermore, calibration curves (e.g., Figure 3) are used to illustrate the error between the XRF measurement (“Calibrated value”) and laboratory result (“Lab value”).

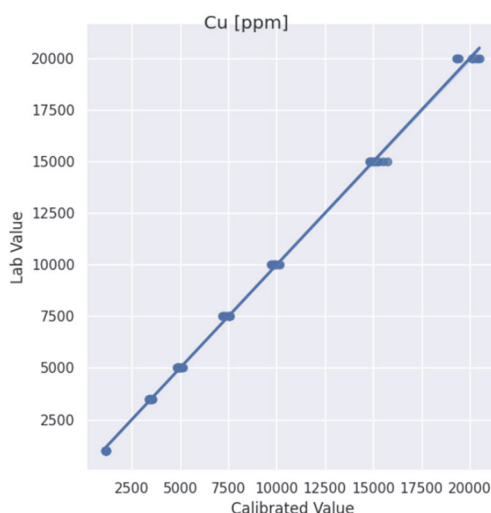
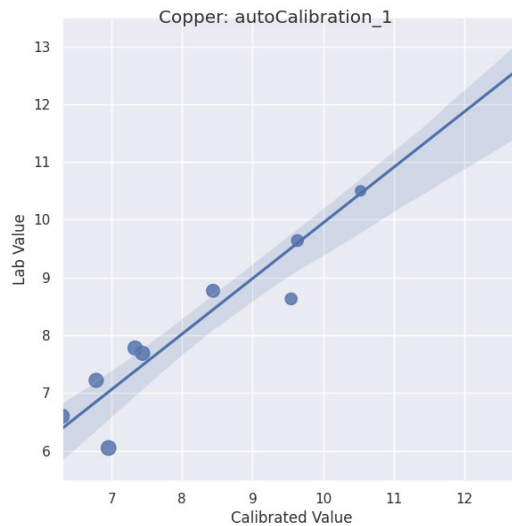

Figure 4. Cu calibration curve obtained from the measurements performed in a controlled environment of  $\text{CuSO}_4(\text{H}_2\text{O})_5$  solutions of different concentrations (MAPE = 4 %, MAE = 170 ppm).





**Figure 5. Cu calibration curve obtained with the training set of the measurements of ore slurries at GTK Mintec (MAPE = 5%, MAE = 0.36%).**

### Baseline experiment in a controlled environment

To demonstrate the reliability of elemental concentration measurements with an XRF analyser when sampling errors can be ruled out, we have conducted a measurement campaign under strictly controlled conditions. To this end, we have used the FLORIDA device to analyse a solutions of Copper(II) sulphate pentahydrate, i.e.,  $\text{CuSO}_4(\text{H}_2\text{O})_5$ , with Cu concentrations in the range of 1000 ppm to 20000 ppm. During all measurements, the spectrum integration time was equal to 60 s and each solution has been measured at least ten times.

The resulting calibration curve of this baseline experiment can be found in **Error! Reference source not found.** It can be observed that all measurements follow the trend of a straight line without any outliers. This is not surprising, since the measurement were unbiased by a material sampling process. It can, however, be further observed, that with increasing Cu concentration, the absolute deviation of the measurements from the ideal curve increases as well, which explains the reported mean absolute error (MAE) of 170 ppm and a mean absolute percentage error (MAPE) of 4%. As previously explained, this behaviour has been expected due to errors introduced by statistical uncertainties<sup>16</sup>. In theory, this statistical error could be reduced by increasing the spectrum integration time, which in turn might make the measurements temporally too far apart to allow for a smooth control of the process parameters. Nonetheless, this experiment underlines the accuracy and robustness of XRF-based online elemental analysis for process control in the mineral processing industry. It must be noted that due to the saturation of the solution at Cu concentrations greater than ~2%, this experiment does not fully correspond to the in-situ experiments at the Mintec plant, where the analysed slurry had a Cu concentration ranging from 5% to 13%. However, this does not mean that the results of this baseline experiment cannot be generalized, since previous experiments with different target elements have shown that the calibration curve continues to stay linear when analysing suspensions with much higher elemental concentrations. The only exception to this statement occurs, when measuring slurries with a very high ore concentration, in which case X-ray absorption effects transform this line into a curve.

### Copper ore measurements at the GTK Mintec mineral processing plant

The goal of the second measurement campaign was twofold: to highlight the stability of XRF-based online elemental analysis in an in-situ application and to empirically demonstrate the errors introduced by material sampling for process control. This measurement series has been performed at the Mintec pilot plant of the Geological Survey of Finland (GTK) from August 26 to 31, 2021.

GTK Mintec<sup>1</sup> is comprised of a mineral processing pilot plant as well as process mineralogy and bench-scale processing laboratories for minerals, ores, geomaterials, and circular economy materials, and belongs to the Circular Economy Solutions unit, which is the largest unit within GTK. Its main purpose is to develop innovations for mineral grinding and beneficiation processes and to provide research services for different industries.

Our experiments took place in a flotation cell of GTK Mintec, where we performed online measurements of the product stream with a FLORIDA XRF analyser, as shown in Figure 1. There, copper ore slurries were prepared and pumped through a pipe segment installed in the FLORIDA XRF device, which obtained a spectrum of the slurry every 60 seconds. At selected intervals, slurry samples were taken from the device's outflow. To ensure comparable results, the sampling procedure was as close as possible to the one that is usually employed at the plant to sample material for laboratory analysis whose results are then used for process control. The spectra corresponding to the sampling times were then used to construct all the calibration curves, which are discussed in the following.

Following the principles of proper validation (PPV)<sup>18</sup>, two sample set were collected: a training (i.e., calibration) set, and a test (i.e., validation) set. The calibration set spectra were used to teach the calibration model, which in turn has been used to construct the calibration curve depicted in Figure 5. This calibration model was then applied to the samples in the validation set to determine its validity (c.f., Table 1).

As in the calibration curve in previous baseline experiment (c.f., Figure 3), the calibration measurements mostly lie on the

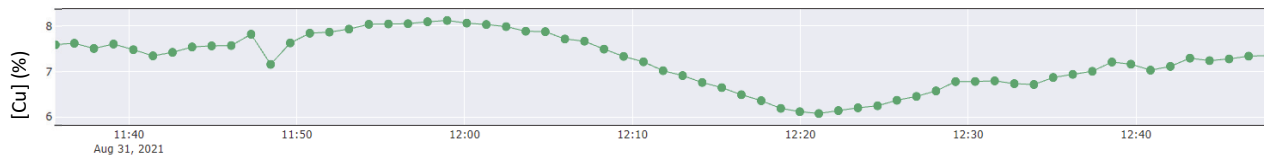

**Figure 6. Evolution of the measured Cu concentration in a copper ore slurry over the course of an hour. The observed changes over time indicate the parameter changes of the process parameters performed during the flotation test, demonstrating the capability of online and inline monitoring of an elemental analyser for mineral preparation.**

perfect calibration curve, this time however, two outliers (i.e., training sample 2 and 5) can be clearly registered. We attribute these outliers to the physical sampling process and not to measurement errors, since in the previous experiment, we have already established the accuracy of the XRF analyser in a setup when sampling errors can be ruled out. Obviously, these ideal measurement conditions of the baseline experiment cannot fully be transferred to the real-world conditions of a mineral processing plant, where an inhomogeneous produce stream, as well as an inappropriate sampling design not accommodating to the material inhomogeneities are always to be expected. Nonetheless, having validated the analyser under perfect conditions decreases the likelihood of the outliers having been caused by the sensor setup and thus increases the confidence to improve the representability of the calibration by dropping the outliers from the training set. However, despite the existence of outliers in the calibration set, the overall accuracy of the analyser is in line with the baseline results, with a MAPE of 5% on the calibration set and 6% on the validation data.

To ensure that these results were not caused by a coincidental assignment of samples to both sets (i.e., calibration and validation data), we have further analysed the effect of data set assignment of these samples, as shown in the calibration curves in Figure 7. Even though both curves are impacted differently by the outliers that were introduced by the sampling process, the measurement statistics are still consistent with the statistic of the original training set (c.f., Figure 5), which highlights the robustness of the calibration procedure to sampling errors. Nonetheless, it should be noted, that this experiment only indicates that an in-line elemental analyser produces results that are robust to sampling errors that occur when assembling a calibration set, however, an appropriate sampling procedure is still of utmost importance, when selecting the calibration samples.

In a final experiment, we have conducted a longer-term measurement with FLORIDA XRF to qualitatively demonstrate its capability. To this end, we have applied the previously described calibration model to the spectra obtained from the copper or slurry to measure the copper concentration within the slurry and plotted the evolution of the Cu concentration over the course of one hour, during which parameter changes of the flotation process were performed. This plot can be found in Figure 6, where the impact of the parameter changes on the Cu concentration can be clearly observed, which further underlines the viability of online and inline elemental monitoring as an alternative to the error-prone and time-consuming laboratory analysis of samples regularly taken from the product stream.

**Table 1. Accuracy achieved when the calibration model is applied to the samples in the calibration set (left) and validation set (right). The accuracies on both sets are similar implying the generalization capability of the model. The two outliers, i.e., training sample 2 and validation sample 1, have most likely been caused by errors introduced by the sampling process and not by the measurement, since the measurement error of the remaining samples is consistently much lower.**

calibration sample No	[Cu] (%)	measured [Cu] (%)	abs. error	rel. error (%)	validation sample No	[Cu] (%)	measured [Cu] (%)	abs. error	rel. error (%)		
1	10.5	10.59	0.09	1	1	4.9	5.87	0.97	20		
2	6.05	7.00	0.95	16	2	11.9	11.35	0.55	5		
3	12.9	12.88	0.02	0	3	9.89	10.70	0.81	8		
4	8.77	8.48	0.29	3	4	6.74	7.14	0.40	6		
5	8.63	9.6	0.97	11	5	7.72	7.90	0.18	2		
6	9.64	9.69	0.05	0	6	9.3	9.47	0.17	2		
7	7.69	7.48	0.21	3	7	8.73	8.04	0.69	8		
8	6.6	6.33	0.27	4	8	7.29	7.51	0.22	3		
9	7.78	7.37	0.41	5	9	8.31	8.2	0.11	1		
10	7.22	6.82	0.21	6	10	6.45	6.24	0.21	3		
<b>Mean calibration error</b>				<b>0.36</b>	<b>5</b>	<b>Mean validation error</b>				<b>0.43</b>	<b>6</b>

## Conclusions

The aim of this work was to highlight the advantages of inline and online elemental analysis of suspensions and slurries for process control in the mineral processing industry. To this end, two measure campaigns have been conducted with the FLORIDA XRF analyser. The first campaign took place under controlled conditions that removed the necessity of material. Its goal was mainly to establish a baseline for the second campaign, which has been undertaken in situ at the Mintec mineral processing plant. The major results of the presented experiments were threefold. Firstly, we have demonstrated the

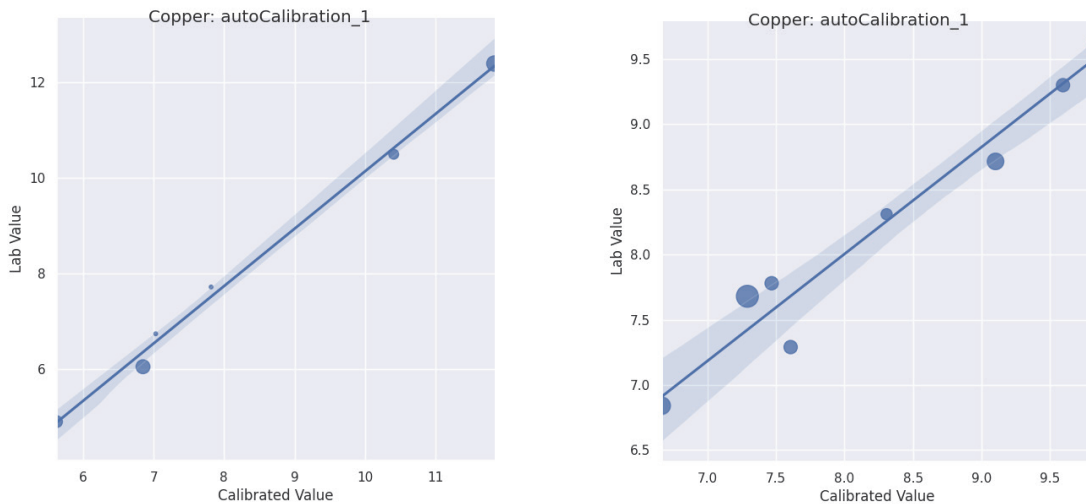

**Figure 7. Cu calibration curves when changing the calibration set assignment of the GTK measurements (left MAE = 0.43%, right MAE = 0.26%). Even though both curves are impacted differently by the outliers that were introduced by the sampling process, the measurement statistics are still consistent with the statistic of the original training set (c.f., Figure 3), which highlights the robustness of the calibration to sampling errors.**

qualitative and quantitative accuracy of inline elemental analysis which highlights its usefulness for process control. The calibration curve obtained based on slurries with precisely generated concentrations show excellent correlation between the inline measurement and the laboratory results. Secondly, we have shown the device's robustness to outliers arising from errors introduced by sampling and probably in the laboratory process reference data that was used for calibration. Lastly, we have highlighted the problems which are related to the use of more or less representative samples from a fluid process stream. Obviously fluid sampling is frequently accompanied by some bias; therefore, the calibration samples show significant differences to the inline analyses. This result also indicates that an analysis in the main stream (inline) should be preferred compared to an analysis in a bypass stream since even continuously working automatic sampling stations cannot guarantee to be free of sampling errors. Overall, our results demonstrate that online and inline elemental analysis a viable alternative to the laboratory analysis of periodically drawn material samples that is commonly used for process control in the mineral processing industry, since it yields sufficiently accurate results, provides immediate, continuous 24/7 measurements, and eliminates some error sources that are inherent to laboratory sampling.

## ORCID iDs

L.Rybok: <https://orcid.org/0000-0002-8896-5282>

A. Nad: <https://orcid.org/0000-0002-2042-8261>

## References

1. A. Nad, M. Jooshaki, E. Tuominen, S. Michaux, A. Kirpala, J. Newcomb, "Digitalization Solutions in the Mineral Processing Industry: The Case of GTK Mintec", *Minerals* **12**(2), 2022. <https://doi.org/10.3390/min12020210>
2. <https://jcbachmann.com/products/florida/> (accessed on 18. March 2022)
3. P. M. Gy, "Sampling for Analytical Purposes", Wiley, 1998.
4. L. Petersen, P. Minkkinen, K. H. Esbensen, "Representative sampling for reliable data analysis: theory of sampling", *Chemometrics and intelligent laboratory systems*, **77**(1-2), 2005. <https://doi.org/10.1016/j.chemo-lab.2004.09.013>
5. D. Hodouin, S.-L. Jämsä-Jounela, M. T. Carvalho, L. Bergh, "State of the art and challenges in mineral processing control", *Control Engineering Practice*, **9**(9), 2001. [https://doi.org/10.1016/S0967-0661\(01\)00088-0](https://doi.org/10.1016/S0967-0661(01)00088-0)
6. B.J. Shean, J.J. Cilliers, "A review of froth flotation control", *International Journal of Mineral Processing*, **100**(3-4), 2011. <https://doi.org/10.1016/j.minpro.2011.05.002>
7. A. Remes, K. Saloheimo, S. L. Jämsä-Jounela, "Effect of speed and accuracy of on-line elemental analysis on flotation control performance", *Minerals Engineering*, **20**(11), 2007. <https://doi.org/10.1016/j.mineng.2007.01.016>
8. <https://www.mogroup.com/portfolio/courier-5x6x-sl-analyzer/> (accessed on 18. March 2022)
9. <https://www.flsmidth.com/en-gb/products/peri-online-slurry-analysis-system> (accessed on 18. March 2022)
10. <https://www.xore.se/boxray-24-onstream-analyzer/> (accessed on 18. March 2022)
11. <https://www.thermofisher.com/order/catalog/product/GSOMNI> (accessed on 18. March 2022)
12. <https://www.scantech.com.au/product/geoscan> (accessed on 18. March 2022)
13. <http://bsi.lv/en/products/ndt-analyzers/-line-xrf-conveyor-analyzer-con-x/> (accessed on 18. March 2022)
14. C. Bachmann, J. Bachmann, M. Cipold, J. Ha, "Online quality control of a coal blending yard", *World Conference on Sampling and Blending*, 2017.
15. B. Beckhoff, B. Kanngießler, N. Langhoff, R. Wedell, H. Wolff, „Handbook of practical X-ray fluorescence analysis”, *Springer Science & Business Media*, 2007.
16. R. M. Rousseau, "Detection limit and estimate of uncertainty of analytical XRF results", *The Rigaku Journal*, **18**(2),

- 2001.
17. J. E. Fernandez, "Rayleigh and Compton scattering contributions to x-ray fluorescence intensity", *X-Ray Spectrometry*, **21**(2), 1992. <https://doi.org/10.1002/xrs.1300210204>
  18. K. H. Esbensen, P. Geladi, "Principles of proper validation: use and abuse of re-sampling for validation", *Journal of Chemometrics*, **24**(3 - 4), 2010. <https://doi.org/10.1002/cem.1310>



## Implementation of a QAQC program for in-situ grade control by Pulsed Fast and Thermal Neutron Activation methods

Henning Reichardt<sup>a</sup>, Ashley Grant<sup>a</sup>, Soheil Koushan<sup>a</sup>, Snezana Petrovic<sup>a</sup> and Oscar Dominguez<sup>b</sup>

<sup>a</sup> Technical Services & Data Integration, Western Australian Iron Ore Geoscience, Minerals Australia, BHP  
125 St Georges Terrace, Perth WA 6000, Australia; E-mail: Henning.Reichardt@bhp.com

<sup>b</sup> Resource Centre of Excellence, BHP  
125 St Georges Terrace, Perth WA 6000, E-mail: Oscar.R.Dominguez@bhp.com

**Following years of development and testing, in-situ chemical assay by Pulsed Fast and Thermal Neutron Activation (PFTNA) has been implemented in mining grade control at BHP Western Australian Iron Ore as a world first. Demonstrating the technical capability and aptness of a new methodology, however, is not sufficient to ensure the sustained quality of reported assay data. The success of moving from testing stage to implementation in active mining grade control, is chiefly dependent on the robustness of ongoing quality control and quality management.**

**This paper shows the steps undertaken to achieve end to end monitoring of data acquired by Blasthole Assay Tools (BHAT) using PFTNA methods. The main challenge for in-situ chemical assay by the BHAT is to design a quality assurance/ quality control program (QA/QC) without a physical sample being collected, and in consequence, without the conventional separation into the focus areas sample collection, sample preparation and laboratory analysis. In this context, the BHAT combines all in one instrument, and different ways to monitor data integrity, repeatability and accuracy need to be established as outlined below.**

**After the validity of a BHAT calibration has been verified and a tool is in operation, data is monitored on a daily basis to check that relevant operational parameters inside the tool are working within defined acceptance limits. Measurement error in the field is monitored with repeat logs in Blastholes, and inter-instrument error by replicate logs of different BHAT units in the same Blastholes. Accuracy and instrument drift over longer periods are monitored by repeated logs in Reverse Circulation (RC) drill holes. Operational parameters, such as neutron output and spectral resolution of the instrument detector are monitored by scheduled logs in dedicated testing facilities. Also, duplicate manual sampling in Blastholes is used to compare grade populations obtained by different sampling methods in mining pits to aid grade reconciliation from mining to production. By routine application of these QA/QC steps, in conjunction with close communication of results to mining teams, the new BHAT technology has been successfully embedded in day to day mining operations.**

### Introduction

Chemical assay data in near real time from non-destructive methods has gained much attention in the minerals industry in recent years. In this context, the implementation of in-situ chemical assay by Pulsed Fast and Thermal Neutron Activation (PFTNA) methods<sup>1</sup> in mining grade control at BHP Western Australia Iron Ore (BHP WAIO) signifies a momentous change in data acquisition. At present, a small fleet of Sodern FastGrade™ 100 units, internally labelled Blasthole Assay Tools (BHAT) is mounted on downhole geophysical logging trucks and collecting assay data in Blastholes in semi-automatic operation.

A big hurdle to clear for new technology is to move from research and testing to production. And even if a new method to acquire chemical assay data passed production tests and is considered fit for implementation, the work to safeguard ongoing quality has just begun. The process of building a calibration model for BHAT instruments<sup>2</sup> that use PFTNA methods, and the validation steps to establish acceptable error and accuracy prior to implementation are not discussed here. Rather, this paper describes how adequate quality is sustained through continuous monitoring of control data. In this context, environmental changes, instrument drift and auxiliary operational parameters are key areas that need to be monitored.

### Field controls in production logging

During production logging in grade control on mining blast patterns, the BHAT units are required to collect one repeat log per shift. The main objective here is to define and monitor repeatability of the process. Because no physical sample is taken and consequently no material is processed at a lab, the repeat logs combine field error and lab error. Major factors to consider as sources of error are the alignment of the instrument in the borehole and environmental conditions. To capture instrument drift, the two logs of the repeat are not acquired directly after one another, but at the start and end of each twelve hour shift. An example of summary results of the field error for the BHAT method in comparison to manual blastcone sampling and in-pit Reverse Circulation (RC) drilling as well as individual results by BHAT unit over a three months period at a mine site are shown in Figure 1. For simplicity, only the main elements with the biggest impact on grade control are included.

area. For these, the same borehole is used as for repeat logs, which means that the borehole is logged overall four times, twice by each instrument. If required, differences between instruments are managed through planned calibration releases.

#### Field Error by Method

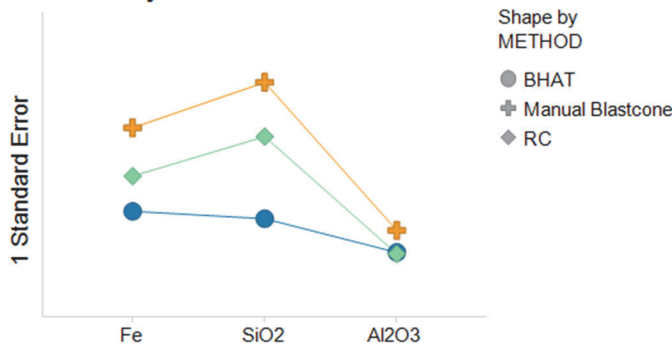

#### Field Error by BHAT unit

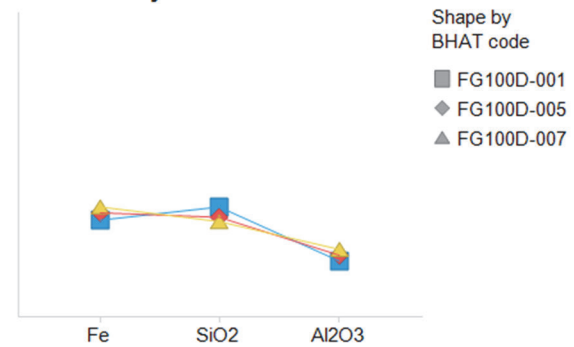

**Figure 1. Summary results for different methods of assay data acquisition at a mining site (left). Note the high error for manual blastcone sampling using shovels and the lowest error for the BHAT method. The plot on the right shows field error for three BHAT units operating at the mine site, showing consistent results. Note: One Standard Error is given as the standard deviation of the absolute difference between sample pairs.**

### Accuracy drift monitoring and matrix changes

In general, monitoring of analytical accuracy of a laboratory is fairly straight forward by using Certified Reference Materials (CRM). For the BHAT method, however, determination of accuracy is more difficult due to the absence of a material that can be used as a true value and the absence of a controlled laboratory environment. The accuracy of a BHAT unit is assessed using a large dataset including at least 7,000 RC drill samples and 3,000 in-pit blastcone samples. After this initial validation process is completed and a BHAT unit is approved for production logging, accuracy is monitored by repeated logs in selected RC holes and by manual twin sampling in Blastholes.

Although individual sample intervals in RC drill holes show large variability and cannot be used as a true value, the repeated logs are appropriate to monitor performance over time and drift from the initial, validated state. The focus here is on monitoring relative changes from log to log, rather than the difference between original assay by XRF methods in the RC drill hole and the BHAT assay for individual sample intervals.

In addition to drift monitoring using RC drill holes, the suitability of an instrument calibration in different matrices needs to be checked in changing operational environments. In particular, moving production logging from one mining pit to another requires an assessment of accuracy in a different matrix. The main differences between mining pits are changes in mineralisation styles, moisture and porosity in the ground among others. The accuracy check is completed by manual twin sampling with a shovel of 20% of the blastcones on a mining pattern (Figure 2). The assay data acquired by manual sampling and subsequent laboratory XRF analysis is compared to the BHAT assays on a mining pattern level and assessed for likeness.

#### Grade populations by method

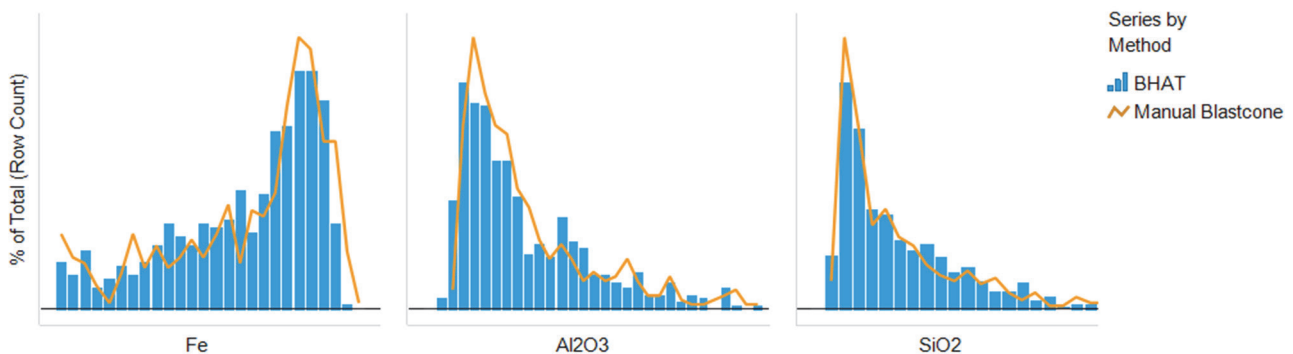
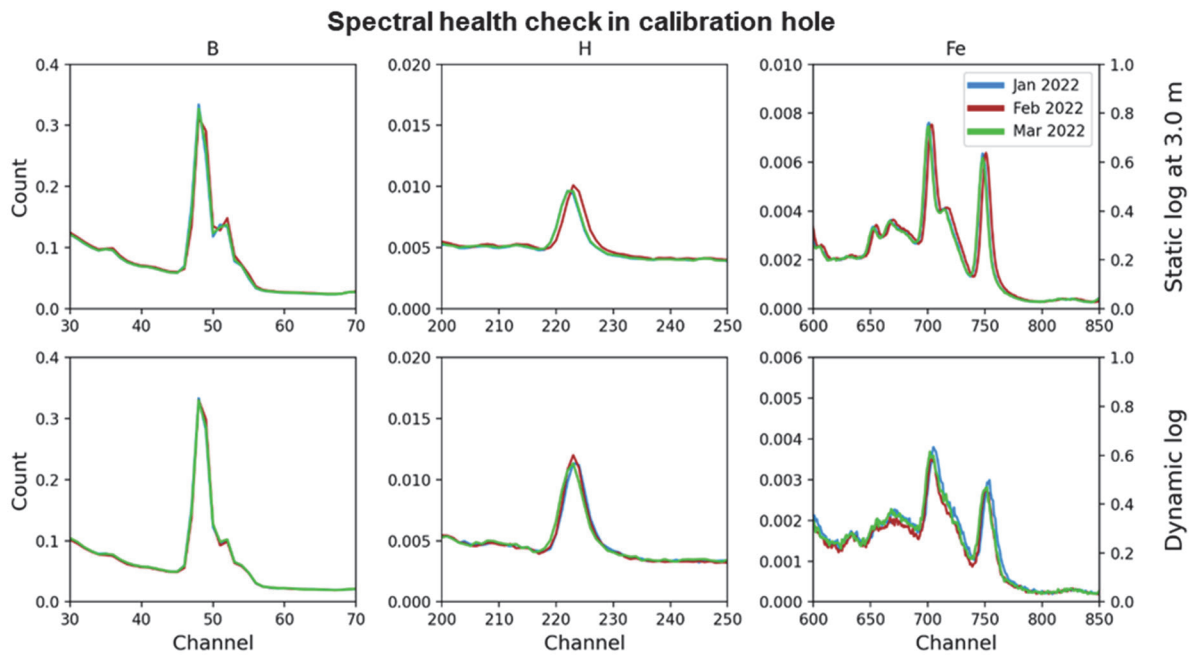

**Figure 2. Illustration of grade populations of main elements on a mining blast pattern. The histograms show assay data collected by BHAT logs in Blastholes and manually twinned blastcone samples.**

### Spectral health

The spectral data acquired by PFTNA methods is processed into chemical assays and the assessment of error and accuracy can be used to communicate QA results for mining grade control. However, monitoring the spectral health of BHAT instruments gives the opportunity to identify potential problems at their onset before issues become apparent in the processed assays. Thus, monthly checks are completed in an artificial calibration hole. A key parameter shown as an example in Figure 3 is the spectral resolution of the instrument detector that conversely influences the ability to process spectra into assays correctly. Further, regular tests in calibration blocks monitor the output of the neutron generator which has an effect on signal strength.

Also, in day to day operations, requirements for spectral health are routinely checked for each reported data file. If predefined limits of spectral peaks are not met, the data is automatically rejected and removed from processing. Minor issues, such as unusual logging depths are flagged for review, but the data can be processed.



**Figure 3.** Monthly test logs in the artificial calibration hole at BHP WAIO facilities. For simplicity, only a selection of parameters is shown. In this example, performance over time is considered acceptable.

### Operational parameters

A crucial part of safeguarding data integrity is checking the reported data formats, borehole logging locations and the performance of auxiliary systems. Incorrect logging locations that do not match planned borehole locations are flagged and raised with the operating company for validation. Also, the processing environment of the signal detector is monitored for temperature, voltage and current (Figure 4). These operational controls are important because all collected data is reported raw by the logging operators and is then processed using in-house propriety programs<sup>2</sup>. This is a major difference compared to laboratory assays that are generally subjected to internal checks before the data is reported to clients.

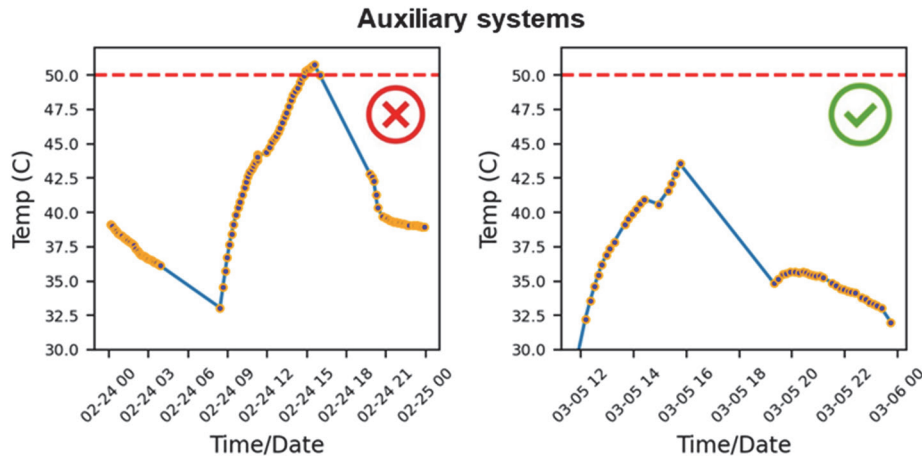

**Figure 4.** Temperature data from a BHAT instrument's Photo-Multiplier Tube (PMT). Voltage and current are not included in this example. The plots show two 24 hour periods that include day and night shifts. In the example on the left, the critical temperature limit inside the instrument was exceeded.

### Discussion

Implementing a QA/QC program for a new technology can be challenging because it is difficult to sufficiently define all sources of error in a test environment alone. Once the technology is embedded in full production, the focus of data monitoring can change based on newly identified gaps, and solutions need to be found quickly. An example of this is that changes in environmental conditions can have a significant impact on spectral health. Specifically, at temperatures above 50 degrees Celsius in the detector environment, the spectral resolution deteriorates. This has been observed in pairs of repeat logs where the first log is collected at the start of a shift in the cool early morning hours and the second log on a hot afternoon. Countermeasures are now put in place to prevent overheating in a pro-active manner. This highlights the importance of continuous monitoring of auxiliary system parameters and regular revision of control parameters based on learnings in the field. Compliance with operation procedures is monitored on a weekly basis and potential issues are raised with field teams. What is important here is good communication between client and contracted operating company to clarify changing requirements and improve on previous results.

Local differences in environmental conditions between mining blast patterns are also identified as contributors to misalignment of the applied calibration. In particular, moisture and porosity in the formation can influence the captured BHAT



spectra and thus the conversion to chemical assays. Also, areas with an unusually high number of ground cavities or otherwise widened borehole diameter, have an effect on spectral results and give rise to problems with signal processing. Manual twin sampling on new mining patterns provides a practical check to see if results have changed compared to the approved calibration model. It needs to be considered though that due to the very high variability of this sampling method, individual sample pairings have limited meaning. However, at a mining pattern level, the grade populations observed in manual blastcone sampling are expected to largely overlap with grades reported by the BHAT. Thus, the mining pattern population analysis can identify these problems should they arise.

Validation of instrument accuracy while in production logging is challenging due to the absence of CRM. Carefully sampled and assayed Diamond drill holes, otherwise regarded as the best case for sampling, are not suitable because the measurement footprint of the instrument extends up to 40 cm distance into the wall rock beyond the borehole and homogeneity of the material cannot be assumed. However, based on previous test work using RC Bulk Sampling and direct comparison of the BHAT method in Diamond and RC drill holes in cross-reference tests, the RC method is considered overall unbiased. Consequently, if the variability of RC samples is taken into account, the mean grades of the reference method (RC) and the test method (BHAT) in relevant element concentrations can be used to establish acceptable accuracy.

A key factor in promoting confidence in chemical assay data by the BHAT method instead of physical sampling methods and laboratory XRF assays, is regular reporting of QA/QC results and good communication with stakeholders. In this way, opportunities to improve can be identified and actions put in place to further build on the consistent quality of results.

## Conclusions

Grade control by PFTNA methods in mining operations at BHP WAIO is now successfully implemented. This has been supported by establishing a QA/QC program that monitors field error, instrument performance over time and operational parameters. Importantly, changes in the logging environment and the rock matrix are also considered. It is emphasized that the work on developing and refining QAQC routines is not finished. Rather, operational procedures and control requirements are regularly updated based on new findings and the growing experience with this new technology.

## Acknowledgements

We greatly appreciate the work by Arthur Maddever and Ben Chi in developing processing models, instrument calibrations and driving analytical capabilities of this new technology further. We also want to thank Jennifer Market and the team at Epiroc for their technical and operational support.

## References

1. C. Smith, P. Jeaneau, R. Maddever, S. Fraser, A. Rojc, M. Lofgren and V. Flahaut, "PFTNA logging tools and their contributions to in-situ elemental analysis of mineral boreholes", TOS forum 5, 157–164 (2015). doi: <https://doi.org/10.1255/tosf.5>
2. Chi, B, Maddever, R A M, Mahanta, A and Dominguez, O. "Near real-time assay with downhole assay tool (Fast-Grade 100)", in Proceedings Eighth World Conference on Sampling and Blending , pp 137-144. The Australasian Institute of Mining and Metallurgy: Melbourne (2017).

## Process analytical technologies for precise, timely and representative elemental and moisture measurement for conveyed flows

H. Kurth<sup>a</sup> and L. Balzan<sup>b</sup>

<sup>a</sup>143 Mooringe Avenue, Camden Park SA 5038 Australia. E-mail: h.kurth@scantech.com.au

<sup>b</sup>143 Mooringe Avenue, Camden Park SA 5038 Australia. E-mail: l.balzan@scantech.com.au

**Abstract:** Industrial and technological processes are very difficult to manage when the quality of feed and product or discard are not measured with confidence. Effective control can occur when process analytical technologies are chosen that provide representative, precise, and timely measurements. For the measurement technique to be representative it must comply with the Theory of Sampling (TOS) and provide an equal chance of any component in the streaming material to be included in the support for the measurement. This generally precludes technologies that measure only the surface of materials, or biased measurements stemming from a limited portion of the material only, particularly in the minerals processing and recycling sectors, which usually display high compositional variability. The location of the analytical technology should relate to the benefit being targeted and allow for enough reaction time to respond to the quality in some way; diverting short increments based on composition and decision parameters based on process impact, blending with other quality materials, or feeding information backwards or forwards. Feed forward options can include flow rate control, reagent control, operational process variables that impact recoveries, etc. Major benefits have been achieved in measuring coarse conveyed flows with high specification Prompt Gamma Neutron Activation Analysis (PGNAA) over short increments (thirty seconds to two minutes) for most elements, or over five to ten minute increments for trace elements, such as gold. PGNAA applied to conveyed flows allow the full flow to be measured continuously and composition averaged for each increment in real time. The use of penetrative and continuous moisture measurement using transmission microwaves has also proved effective for moisture monitoring and management. Precisions between laboratory samples of the flow and analysis data from analysers can be sufficient to have high confidence in resulting process control decisions. This paper explains the benefits in more detail and includes case studies to highlight actual benefits derived from the application of such systems. It should be noted that sampling of the materials is still required for calibration and adjustments for the process analytical tools.

### Introduction

In order to obtain optimal efficiency gains in a process, it is imperative that process control is acting on the best quality data available. By measuring various properties of a process, control can be implemented based on relevant data to obtain improvements to the process. Measuring the quality of the feed or product and discard of a process can enable decisions to be made based on the measured quality and the economics of the day. For these decisions to be effective, it is critical that the measurements are made with confidence and thus that any process analytical technologies employed are able to provide results that are representative, precise, and timely for the process. Satisfying the need for measurements to be representative is a fundamental requirement from the Theory of Sampling (TOS), which requires that all material has an equal probability of influencing the measurement outcome without preference to any specific component<sup>1</sup>. This implies that any measurement system that preferences one aspect of the measured material, such as a surface measurement, or a measurement of a small part of a flow cross-section only is by definition not representative than one that is able to measure without bias.

In addition to being able to make representative measurements, it is also important that measurements are made in a timely way to allow proper process actions to take place. It has often been seen that being able to provide representative analysis is traded off against being able to provide timely analysis. Sensors may be fast, but not representative; optical sensors are typically able to provide rapid analysis, but are a surface-only measurement technique, and are affected by variations in particle size and weathering, flow height variation, or even dust. By contrast, techniques such as prompt gamma neutron activation analysis (PGNAA) utilise radioactive interactions and are fully penetrative of the material flow, however being a statistical analysis technique, they require that a sufficient integration period lapses to make a confident measurement<sup>2,3,4</sup>. Despite such perceptions, there have been various developments with Scantech's GEOSCAN PGNAA analyser that has allowed for drastic reductions in analysis times, which has been an enabler for the GEOSCAN to be utilised as a tool in bulk diversion applications<sup>5,6</sup>. The use of PGNAA has been well established as providing representative and precise measurements of conveyed flows in a variety of industries including cement<sup>7</sup>, iron ore<sup>8</sup>, manganese<sup>9</sup>, copper<sup>10</sup>, lead zinc<sup>11</sup>, phosphate<sup>12</sup>, and even gold<sup>13</sup>, with the demonstration of rapid analysis providing the final demonstration of comprehensive effectiveness for process analytical technology to supply optimal analysis of the quality of conveyed flows of material. The technology has been demonstrated to lead to gains in material handling and processing and economic gains, particularly on highly variable or heterogeneous material flows<sup>14, 15</sup>.

This paper seeks to demonstrate how the use of the GEOSCAN's PGNAA technology can lead to optimised outcomes for process control. A brief summary of the technology and how it works is provided, followed by examples of analysis performance in key industries of copper and gold, where very different measurement metrics are necessary. An outline of how the technology can be employed to lead to economic benefits is presented, contrasted with outcomes in the case of where a faster but less precise measurement system is employed. An outline of future possibilities concludes the paper.

## PGNAA Technology

Scantech's GEOSCAN on belt analyser utilises prompt gamma neutron activation analysis (PGNAA) to determine the elemental composition of conveyed bulk materials in real-time. Also referred to as thermal neutron capture, the technology utilises a californium-252 radioactive source located within the instrument below the belt to generate a flux of neutrons. These neutrons are then absorbed by the conveyed material as it passes through the tunnel of the GEOSCAN. The neutrons are captured by the nuclei of the atoms in the material flowing on the belt, and gamma-rays are instantaneously produced with a unique energy distribution for each element. The gamma-ray spectrum is captured by an array of high performance detectors located at the top of the GEOSCAN, where Scantech's signal processing algorithms resolve the signal into a set of individual elemental results.

The measurement technique is completely penetrative allowing for analysis of the full material stream, figure 1. The physics of measurement and geometry of the GEOSCAN spectrometer allow for the entire bed-depth and belt-width to be measured. It is independent of ore mineralogy, particle size, segregation or layering in the flow and belt speed, thereby allowing for fully representative analysis of the conveyed material. Obviously not every single atom or every element present in the increment of conveyed flow is measured due to limitations of the physics involved, but the many gamma emissions detected within each measured increment has been demonstrated to result in acceptable precisions for the purposes of the measurement data and responses to it<sup>3,5,6,11,12,13,16</sup>. Radioactive decay of the source is occurring continuously, such that all material is analysed all the time. Thus GEOSCAN measurements do not suffer from delimitation nor extraction sampling errors (IDE, IEE), contrary to what is often the case with other approaches, such as measuring only from the top surface of the moving matter, or is only interacting with a longitudinal strip, or small section, of the cross-section of the flow. Results are produced for a suite of elements calibrated for the specific requirements of the particular application, which can vary from installation to installation, and is tailored to account for variation due to changes in the belt load and material composition.

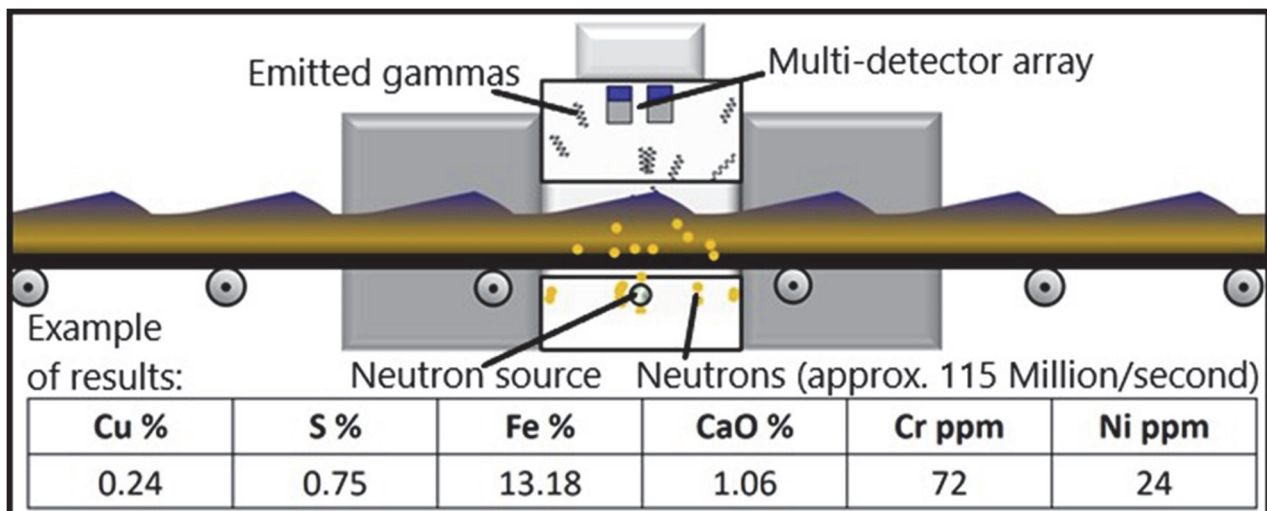

**Figure 1. Cross-section through the GEOSCAN analyser showing the components of the system illustrating why it delivers representative measurements. The technique is continuous, penetrative and measures elements randomly with a penetration depth >0.5 metres. The conveyed flow passes through the tunnel where neutrons are dispersed to cover the full width and depth cross section.**

Additionally, moisture measurement can be made using a through-belt moisture (TBM) analysis system. The TBM utilises a microwave transmission measurement technique to directly measure the moisture content of the conveyed material, and is typically installed alongside the GEOSCAN, therefore providing both elemental and moisture results. The TBM has undergone scrutiny for use within the iron ore industry and has become widely accepted for its high level of accuracy<sup>16</sup> in this and the majority of commodities in the minerals industry.

Results from the GEOSCAN and TBM are output to the plant control system typically every two minutes in the majority of installations. This analysis period has been traditionally selected as it allows for sufficient time for reliable and repeatable results while minimising inherent randomness from radioactive decay. In the majority of cases, this analysis period is also fast enough to provide results that can be acted upon in downstream process control (feed-forward control) or upstream material management (feedback control) as required. In 2016, Scantech recognised a need to increase the speed of analysis so that the GEOSCAN data could be used to determine process control decisions on small material flow increments, and thus to enable the concept of bulk sorting based on representative and accurate analysis. Scantech undertook research to satisfy this requirement and has since been able to have analysis performed rapidly in as short as 30-seconds while maintaining the repeatability statistics (precision) expected over longer integration periods.

## Case Studies

This section aims to outline several examples in key commodities where analysis of the conveyed flow has been demonstrated to be representative, precise and timely. The concept of bulk diversion of feed presents a useful example to demonstrate this capability, as it necessarily requires analysis to be sufficiently fast for the process, while requiring results to be representative and accurate to be able to derive economic benefits.

Scantech has had a long history with over 35 years of experience in bulk sorting<sup>17</sup>. The earliest examples involve measurement in coal and diversion based on ash measurement using a flop-gate diverter, and longer analysis increment diversion has been implemented successfully in iron ore. In more recent times, the approach has focused on rapid analysis in base and precious metals commodities, with some results outlined below. It has been observed at multiple sites that high precision measurement provides a significant reduction in misallocation of material than lower precision measurement, even when the latter measurement occurs over shorter time increments.

### Base Metals

One of the key areas of interest in bulk sorting has come from base metals commodities such as copper and nickel. Scantech has implemented many copper bulk diversion projects around the world, including two in Canada, two in Chile, one in Peru, and two in Australia, plus two projects in nickel at sites Brazil and Australia respectively. Each site has taken a different approach depending on local requirements, but in all cases, a similar process has been undertaken in the development of successful bulk diversion.

The first steps involve successful and reliable calibration of the GEOSCAN, calibrated against samples collected and subsequently verified using the same method. The next step involved characterisation of the material variability by collecting 30-second GEOSCAN analysis over a period and evaluating the variability considering the economics of diversion. From this study, suitable analysis periods have been selected (usually 30-seconds, but in some cases, 1 minute or 2 minutes), and the bulk diversion regime implemented accordingly. Customer feedback has suggested improvements in ore grade from 10% to 30%. Paramount to this success is the GEOSCAN's analysis performance, with figures 2 and 3 below showing results for copper and nickel respectively.

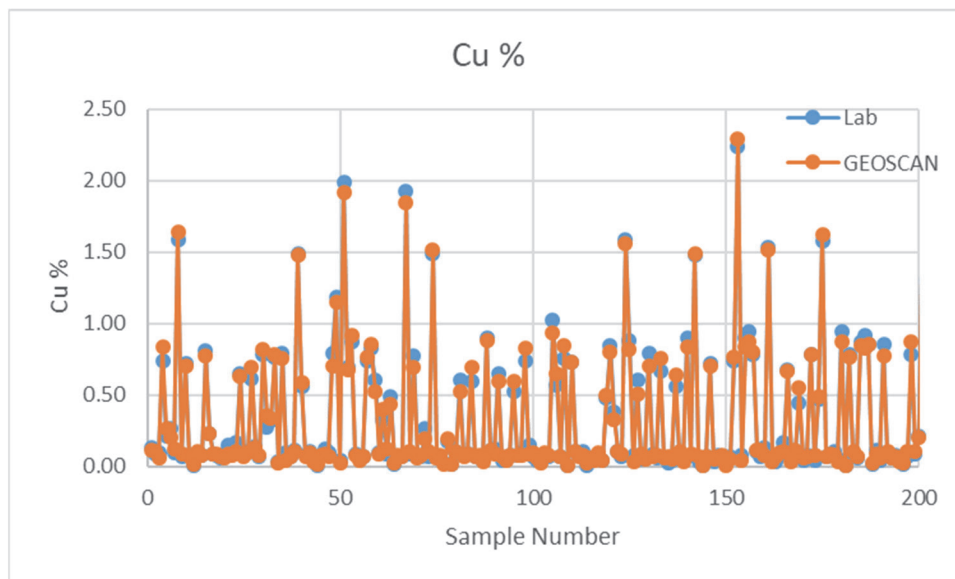

Figure 2. GEOSCAN and laboratory results for Cu %

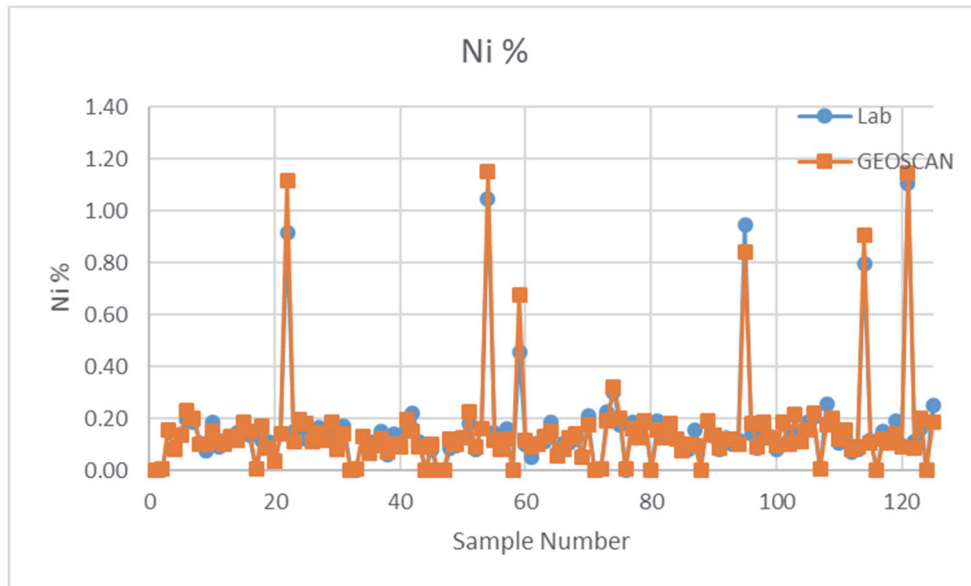

Figure 3. GEOSCAN and laboratory results for Ni %

### Precious Metals

Recent developments in analysis capability have allowed for the direct measurement of precious metals in ore using PGNAA<sup>13</sup>. Due to the typically low concentration of precious metals in ore, analysis of these elements is typically required over longer measurement timeframes than for other elements. A longer integration time allows for adequate measurement statistics so that sufficient confidence in any result can be attained. This means that direct measurement of elements like gold, silver, and platinum cannot be used in a typical bulk diversion system, where 30-second analysis is usually required. However, for many sites, there are strong correlations between elements like gold or platinum and other elements that can be readily measured on a 30-second basis. This has formed the basis for a number of installations of bulk diversion for precious metals, including two in Africa, one in Canada and three in Australia where precious metals are reported by proxy measurement of other elements including sulphur, copper, and nickel. It should be noted that the calibration of the analyser and its reporting of the calculated element from the proxy is based on establishing useful correlations from laboratory data for each rock/ore type. The degree of correlation is therefore a limiting factor in determining the precision between calculated values and those derived from representative sampling and laboratory assay. Figure 4 below highlights the GEOSCAN's performance in such proxy measurement for gold. Such performance is possible over a longer period of direct measurement, say 5 or 10 minutes, and can be observed in figure 5.

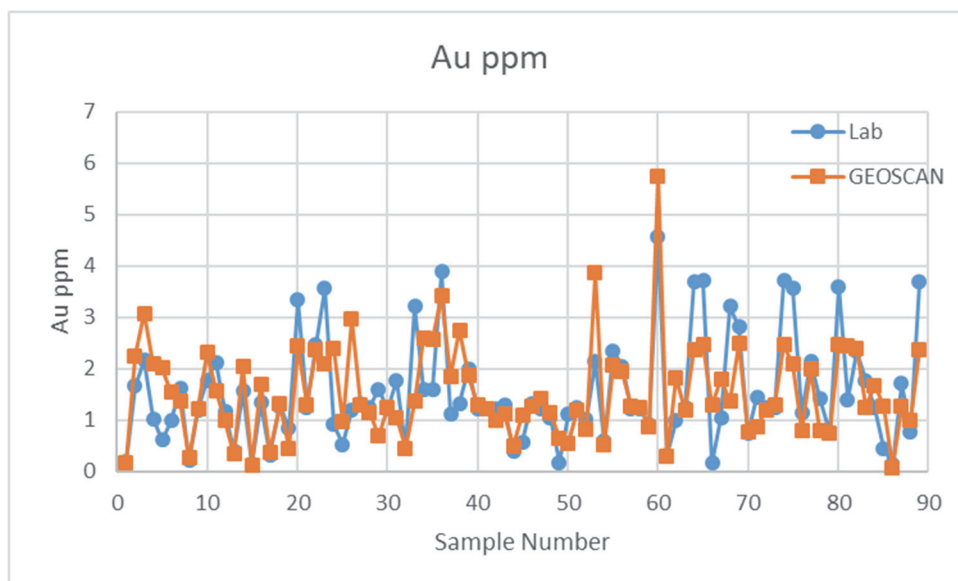
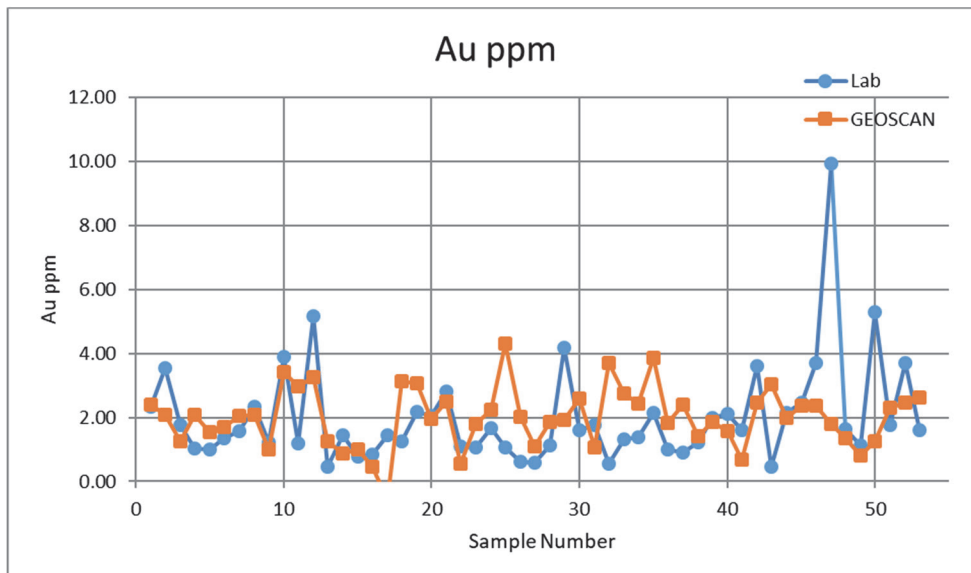

Figure 4. GEOSCAN and laboratory results for Au ppm using proxy measurement



**Figure 5. GEOSCAN and laboratory results for Au ppm using direct measurement. Laboratory results are based on very small sub-samples which lead to relatively high sampling variability due to the nugget effect, while GEOSCAN senses all the conveyed flow continuously providing an average analysis over a longer increment interval.**

### Benefits of representative, precise and timely measurement

Modelling of data based on 2,000 sequential 30-second measurements of copper in a copper-gold ore stream at a rate of approximately 1,200 tonnes per hour demonstrates the benefit of more precise measurement over less precise measurement. The measured data from the GEOSCAN was assumed to be the actual grade data and then estimated measured quality was determined by randomly varying the error applied so that the average error to model the GEOSCAN measurements were similar to the actual 0.03% Cu precision determined based on RMSD between analyser and laboratory data at the site for samples removed from the belt. The distribution of results is plotted (figure 6) and expected cut-off grade shown for the “actual” results and those of the modelled measured results. Increments are considered misallocated if the classification of that increment is not consistent between actual and measured values relative to the cut-off grade. Increments that have a measured grade below cut-off but an actual grade above cut-off are ore misallocated as waste. Increments that have a measured grade above the cut-off but an actual grade below cut-off are waste misallocated as ore.

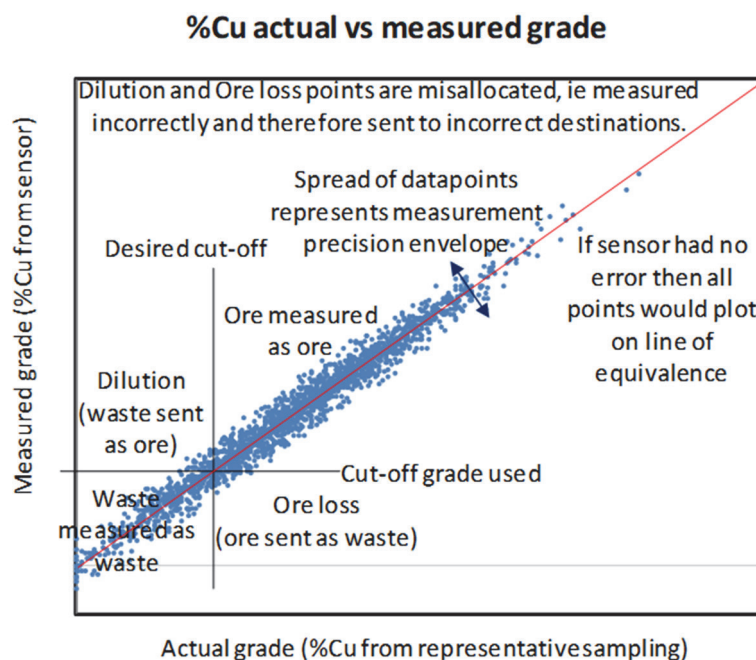
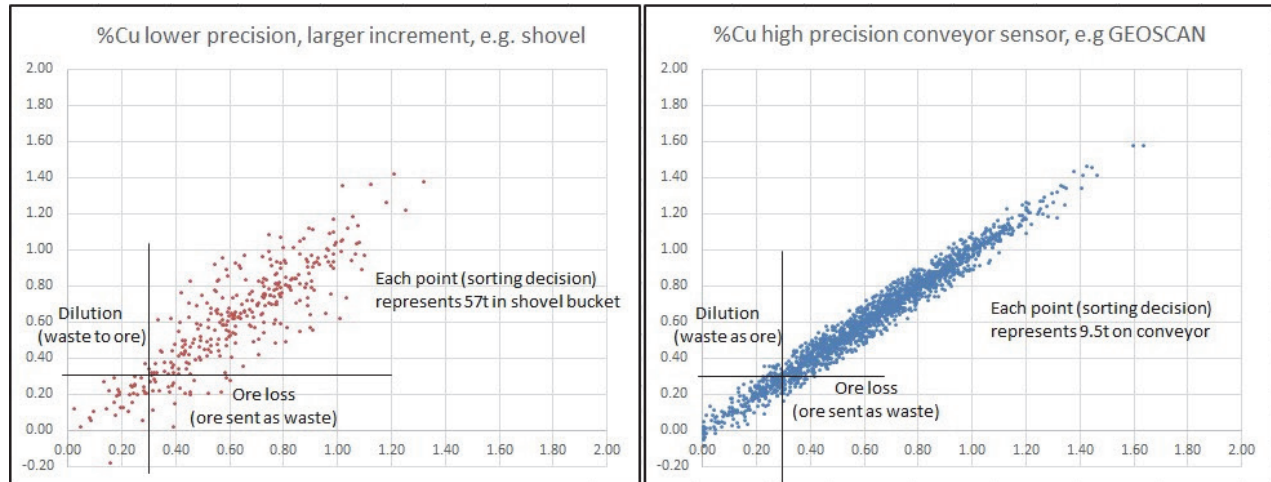

**Figure 6. Modelled actual vs modelled GEOSCAN results for %Cu based on 2,000 measurements each representing average copper content of each 30 seconds on a 1,200t/hr conveyed ore flow at an existing copper-gold mine**

Less precise increments were assumed to have a precision 0.05%Cu larger than the GEOSCAN precision in the modelling exercise. This difference may be very conservative when considering that the common techniques marketed against high specification PGNAA are surface analysis methods, such as x-ray fluorescence (XRF), laser-induced breakdown spectroscopy (LIBS), hyperspectral and near-infrared (NIR), and hence results shown here should be considered as a minimum difference in recovered values of contained copper metal to the ore stream. Surface analysis techniques either extrapolate the measurement to the full volume based on some artificial intelligence applications (i.e. assumptions on grade deportment, particle size distribution, etcetera), or simply assume the surface of the flow is representative of the full volume (which is

known to be almost never the case for primary crushed conveyed rock). Conveyed flows are often seen to segregate by particle size through the conveying action and surface analysis techniques may effectively limit penetration to the dust coatings on the rocks in the analysis area. Natural heterogeneity present in the conveyed material may further vary for different material types as changes in the mineralogy will also affect fragmentation and hence segregation.

When modelling measurements with a poorer precision we look to what the mining industry has been implementing to understand the consequences of applying various sensor technologies and resulting data quality. To assess the differences in outcomes between measurement precisions we model data with poorer precisions and combine results to model differences in increment size. Figure 7 effectively models the different between a shovel sized increment and a 30 second conveyed flow increment with respective measurement precisions based on sensing techniques applied (XRF and high specification PGNAA respectively) using a conservative difference in precisions.



**Figure 7. Each dot on the left graph represents the equivalent of a shovel load from 57 t using a best case precision estimate and the dots on the right are 9.55 t using a 30 second conveyed analysis period at worst case precision estimate. The same initial total tonnage and grade variation is used in both.**

Mining shovels (excavator buckets) used in open pit mining operations are large capacity equipment, commonly in the 50 t to >100 t range. For the purposes of this paper, we used six increments of the measured conveyed flow to represent the equivalent of a shovel. Larger shovel sizes would have to be represented by a higher number of smaller increments and would have provided a less conservative comparison. Data in Figure 7 was used to determine the differences in expected copper metal recovery when decisions were based on the different estimates of the material quality. Larger increments measured at poorer precision than the conveyed increments using better precisions, resulted in larger proportions of waste misallocated as ore and ore misallocated as waste as demonstrated in Table 1. This supports the conclusion that more precise analysis provides better outcomes in ore and waste designation and therefore leads to improved outcomes in bulk ore sorting.

**Table 1. Modelled allocation of rejected and recovered proportions comparing a short conveyed increment to six times decision increment. The shorter more precise measurement recovered a net 3.5 per cent more Cu metal to the mill, valued at approximately USD21 million per annum (assuming a copper metal price of USD 10,000 per tonne).**

	30 seconds conveyor flow			Bulked up to shovel bucket size		
	No. of 9.55 t increments	Tonnes	%Cu	No. of 57 t increments	Tonnes	%Cu
Waste as waste	241	2299	0.181	30	1812	0.199
Ore as waste	28	269	0.335	22	1265	0.419
<b>Total to waste</b>	<b>269</b>	<b>2569</b>	<b>0.197</b>	<b>52</b>	<b>3077</b>	<b>0.290</b>
<b>% Reject</b>		<b>13.4%</b>			<b>16.1%</b>	
Ore as ore	1699	16 227	0.691	275	15 647	0.692
Waste as ore	32	303	0.275	6	354	0.210
<b>Total sent to mill</b>	<b>1731</b>	<b>16 529</b>	<b>0.683</b>	<b>281</b>	<b>16 001</b>	<b>0.681</b>
<b>% Recovery</b>		<b>86.6%</b>			<b>83.9%</b>	
<b>% Cu metal to mill</b>			<b>95.8%</b>			<b>92.3%</b>

To test that the misallocation was simply not due to the larger increment size being considered less selective, the modelling was repeated using a comparison of smaller increment size (representing 10 second measurements) at a poorer measurement precision compared with the 30 second analysis increment at better precision. Results are summarised in Table 2. Again the more precise measurement provided the better outcome primarily because increments covering a larger overall tonnage were correctly allocated.

**TABLE 2. Modelled allocation of rejected and recovered proportions comparing a short conveyed increment to increments one third of the size. The more precise measurement (despite being a larger increment) recovered a net 2.5 per cent more Cu metal to the mill, valued at approximately USD15 million per annum.**

	30 seconds conveyor flow			10 seconds conveyor flow		
	No. of 9.5 t increments	Tonnes	%Cu	No. of 3.2 t increments	Tonnes	%Cu
Waste as waste	210	2009	0.187	617	1976	0.175
Ore as waste	35	333	0.325	333	1067	0.414
<b>Total to waste</b>	<b>245</b>	<b>2342</b>	<b>0.207</b>	<b>950</b>	<b>3043</b>	<b>0.259</b>
<b>% Reject</b>		<b>12.3%</b>			<b>15.9%</b>	
Ore as ore	1727	16 494	0.681	4822	15 429	0.704
Waste as ore	25	242	0.271	196	626	0.246
<b>Total sent to mill</b>	<b>1753</b>	<b>16 736</b>	<b>0.675</b>	<b>5018</b>	<b>16 055</b>	<b>0.686</b>
<b>% Recovery</b>		<b>87.7%</b>			<b>84.1%</b>	
<b>% Cu metal to mill</b>			<b>95.8%</b>			<b>93.3%</b>

Comparison of more precise analysis results with less precise results demonstrate that the less precise measurements result in higher proportions of ore and waste misallocations than for more precisely measured increments irrespective of increment size<sup>18</sup>.

It can be concluded that more precise, representative and timely measurement will result in greater confidence in decisions when appropriate to the context in which decisions are required. The benefits are seen in many of the bulk sensing and diversion (bulk ore sorting) applications in which such analysers have been supplied. Furthermore, as a process analytical technology these systems provide high levels of confidence in any decision-making based on the measurement data. Operators at mine sites can, and do depend on the real time measurement data to monitor conveyed material quality and are prompt to respond when corrective actions are needed. These can include ore blending control, additive proportioning, feed forward to downstream operations to improve process performance including metal recovery, and automating responses where needed.

The measurement data can be confidently used for feedback to mining operations, ore reconciliation and metal accounting as it is considered by metallurgical and process engineers to be the most objective and representative analysis of the conveyed flows taking material from the mining operations and feeding their processes. Geologists and mining engineers have also become comfortable with the quality of the measurement data which minimises their dependency on sampling faces, stockpiles and conveyed flows that are difficult to sample safely, easily or representatively.

Moisture measurement is used in dry tonnage determination for metal accounting and ore reconciliation, dust management, transportable moisture limit (TML) monitoring during ship loading, dryer and filter control loops, and alarming when moisture levels in sticky material are elevated and correspond with materials handling system blockages. At a major USA gold operation with dry tonnage processing licence limit, the introduction of a moisture analyser has resulted in a 3 percent increase in ore feed, equivalent to USD 75 million per year of contained gold value able to be processed. They had previously over-estimated their feed moisture content and had therefore limited their throughput.

Further applications of these measurement technologies can include:

- automating grade control particularly for in-pit crushing and conveying operations (IPCC) where ore and waste can be diverted and separately conveyed from the pit,
- operational geometallurgy where ore type and waste type characterisation can be used in conjunction with digital twins to optimise process performance in real time, where ore hardness can be used in managing grinding mill feed rate, and deleterious and acid-consuming content used to adjust reagent control,
- separation of clean waste from acid generating waste to better utilise mining waste and improve environmental management.

## Conclusion

This paper discussed how representative analysis of conveyed flows can be implemented utilising Scantech's GEOSCAN PGNAA analyser. An explanation of the analysis technique was provided, together with case studies that have demonstrated the performance of the equipment in a range of commodities. An exploration of the benefits of representative analysis using such a methodology has been provided, together with a comparison to a less accurate and less precise measurement system that utilises alternative and less representative measurements. Even with conservative assumptions on the performance differences expected with less representative analysis, the economic benefits are seen to be significant. The paper summarises the benefits that can be gained by using representative analysis for near real-time measurement of conveyed flows.

## ORCID iDs

H. Kurth: <https://orcid.org/0000-0002-4683-5164>

L. Balzan: <https://orcid.org/0000-0003-0447-7888>



## References

1. F.F. Pitard, "Pierre Gy's sampling theory and sampling practice: heterogeneity, sampling correctness, and statistical process control", 2<sup>nd</sup> Edition. CRC Press. ISBN 0-8493-8917-8 (1993).
2. L. Keeney, D. La Rosa, P. Walters, J. Rutter, and M. Scott, "Evaluation and operationalisation of bulk sensing technologies: insights from real world case studies", in *Proceedings of Preconcentration Digital Conference 2020*, AusIMM, pp. 52—65 (2020).
3. M. Scott, J. Rutter, J. du Plessis, and D. Alexander, "Operational deployment of sensor technologies for bulk ore sorting at Mogalakwena PGE Mine", in *Proceedings Preconcentration Digital Conference 2020*, AusIMM, pp. 169—181 (2020).
4. W. Valery, K. Duffy, P. Holtham, A. Reple, P. Walker, and P. Rosario, "Techno-economic evaluation of bulk ore sorting for copper ore at the PanAust Phu Kham operation", in *Proceedings of XXVIII International Mineral Processing Congress*, Canadian Institute of Mining, Metallurgy and Petroleum (2016).
5. L.A. Balzan, A.R. Harris, and Z. Bauk, "Faster analysis: recent advances in GEOSCAN on-belt analysis techniques allowing for rapid real-time measurement of minerals", in *Proceedings of COM2017 Conference of Metallurgists*, Canadian Institute of Mining, Metallurgy and Petroleum (2017).
6. L.A. Balzan, H. Kurth, "Rapid GEOSCAN fully penetrative analysis enabling bulk diversion", in *Proceedings of Sensor Based Sorting and Control Conference*, RWTH Aachen (2022).
7. A. Harris, K. Smith, and F. Rossi, "On-belt analysis breakthrough", *International Cement Review*. October 2005, pp. 62—66 (2005).
8. D. Matthews, and T. du Toit, "Real-time online analysis of iron, validation of material stockpiles and roll out for overall elemental balance as observed in the Khumani Iron Ore Mine South Africa", in *Proceedings Iron Ore 2011*, AusIMM, pp. 297—305 (2011).
9. L. Balzan, and A. Harris, "Adaptation and performance of GEOSCAN on-belt analysers for manganese ore at Assmang Black Rock", in *Proceedings Africa Australia Technical Mining Conference 2015*, AusIMM, pp. 125—130 (2015).
10. T. Arena, and J. McTiernan, "On-belt analysis at Sepon copper operation", in *Proceedings MetPlant 2011*, AusIMM, pp. 527—535 (2011).
11. M. Patel, "On-belt elemental analysis of lead-zinc ores using prompt gamma neutron activation analysis", in *Proceedings XXVII International Mineral Processing Congress 2014*, Gecamin: Santiago, Chile, chapter 17 (2014).
12. L.A. Balzan, and M. Kalicinski, "GEOSCAN-M Use For Process Improvement in Phosphate Plants", "SYMPHOS 2019", *5th International Symposium on Innovation and Technology in the Phosphate Industry*, Procedia Engineering (2019).
13. L.A. Balzan, A. de Paor, A. Doorgapershad and W. Futcher, "The end of the rainbow: real time direct gold analysis in run of mine ore at Newcrest's Telfer mine using GEOSCAN analysis", in *Proceedings of International Mineral Processing Congress Asia-Pacific 2022 (IMPC Asia-Pacific2022)*, AusIMM, in preparation (2022).
14. S. Nadolski, M. Samuels, B. Klein, and D. Hart, "Evaluation of bulk and particle sensor-based sorting strategies for the New Afton block caving operation", in *Proceedings 8th International Conference, Sensor-Based Sorting & Control*, RWTH Aachen (2018).
15. H. Kurth, "Sampling or on-line analysis – which to use when", in *Proceedings of Ninth World Conference on Sampling and Blending*, Beijing General Research Institute of Mining and Metallurgy, pp. 737—745 (2019).
16. L. Balzan, and A. Harris, "Real-time through-belt moisture analysis for iron ore", in *Proceedings Iron Ore Conference 2015*, AusIMM, pp. 539—542 (2015).
17. H. Kurth, and L. Balzan, "Bulk sensing for effective ore sorting – learnings over 35 years", in *Proceedings Preconcentration Digital Conference 2020*, AusIMM, pp. 238—247 (2020).
18. H. Kurth, "Ore quality measurement and control using GEOSCAN-M PGNA real time elemental analysis", in *Proceedings International Mining Geology Conference 2022 (IMGC2022)*, AusIMM, pp. 338—345 (2022).

## Moisture determination. Mass loss on drying – Commercial sampling washed away

D. Aldwin Vogel

Alfred H. Knight International Ltd, Raamsdonksveer (the Netherlands). E-mail: aldwin.vogel@ahkgroup.com

**What is this? Sampling washed away; "samplewashing?" Greenwashing is a known term nowadays, but is there such a thing as "Samplewashing" too? Yes and no: Greenwashing is the process of conveying a false impression or providing misleading information about how a company's products are more environ-mentally sound. ... Greenwashing is a play on the term "whitewashing," which means using misleading information to gloss over bad behaviour. And that is what this sampling paper is all about: presenting moisture results on samples of solid bulk materials where the theory of sampling was not applied... and therefore sampling errors are magnified by not only glossing over the representativeness of the process, but at the same time by watering-down the monetary profits of the trade for one whilst condensing them for the other party. It really is "Samplewashing" when it comes to moisture determination!**

### Introduction

Quantification of the moisture content is one of the main "value influencers" for traded solid bulk commodities where transactions are made and paid on the basis of its unofficial unit of measurement, or the "DMT" - Dry Metric Tonne. Googling for "what is DMT," we quickly run into the commodities glossary at IndexMundi for dmtu, or dry metric tonne unit<sup>1</sup>: "as the internationally agreed-upon unit of measure for iron ore pricing it has the same mass-value as a metric tonne, but the material has been dried to decrease the moisture level. A dry metric tonne unit consists of 1% of iron (Fe) contained in a tonne of ore, excluding moisture." Not much there eh? Drying the whole tonne how; what temperature?

Decrease moisture to what level? Maybe commercial contracts provide some guidance as encountered on the Google quest to learn about moisture? Law Insider to the rescue with an appropriate example. Its Iron Ore Royalty Agreement<sup>2</sup> states: "Article 1.1 - Dry metric tons means the actual weight of Iron Ore calculated on a moisture-free basis. Methods of sampling, testing and calculating moisture-free weight shall conform to methods described in Article 5: Sampling, Assay, and Analysis." Excellent! We have just learned that the material should be in fact moisture-free and it also appears that calculation is done using testing on a sample.

Let's continue and find out how with referenced Article 5 of same agreement: "Article 5 - Sampling, Assay, and Analysis. Any determination of weight, volume, moisture content, or pay metal content, and any sampling and analysis required pursuant to this Article 5 shall be made in accordance with sound mining and metallurgical practices and standard sampling and analysis procedures prevailing in the Iron Ore mining and milling industry by an independent inspector mutually agreed to by IMG and the Agent. Upon the request of the Agent, but no more than three times in any 12-month period, IMG shall cause such inspector to take three samples and provide one such sample to IMG, a second sample to the Agent and retain a third sample in the event of a dispute among the Parties in respect thereof. All statements or reports wherein such independent inspector's assay of samples are set forth shall be conclusively presumed to be true and correct, unless, within ninety (90) days after such statements or re-ports are delivered to the Agent and IMG, either the Agent or IMG makes written objection thereto and demands an assay by an independent referee mutually agreed to by IMG and the Agent. Unless such objection and demand are made within such 90-day period, the independent inspector shall have no duty to preserve the third sample after the end of such 90-day period." Such absolute horror, but such a reality! If you do not see it yet, I will tell you why in this paper.

### Pay metal content

This article will go over some key sentences of Article 5 of the Iron Ore Royalty Agreement mentioned above. These key sentences of Article 5 will be like the table of contents for of this document.

Whereas the Iron Ore Royalty agreement is a specific contract, its wording is very similar to trade contracts seen by the author. Taking things from the top of Article 5: Pay metal content. Pay Metal Content really is the culmination of all determinations that are required to have a commodity change ownership and decide on its price. It looks as if it is built up from weight, volume, moisture content and of course the analysis of the element of interest. Leaving the frivolous reference to volume aside, as this should not feature at all in a commercial contract covering solid bulk commodities, at this stage I would only want to point out the careless use of the term weight determination. As pointed out in one of my other papers (Vogel & Esbensen, 2021)<sup>3</sup> weighing deserves proper attention and clarification if used for commercial settlement transactions, the impact of errors in mass determination may overshadow all other sampling and testing errors.

### Sound mining and metallurgical practices and standard sampling and analysis procedures prevailing in the Iron Ore mining and milling industry

Remembering that the referenced IndexMundi article is about DMT and also mindful that we are trying to find out its 'what' and 'how', then it is pretty disappointing to find ourselves with a set of undefined terms in the example Iron Ore Royalty Agreement. In the example agreement we find terms such as 'Sound mining' and 'metallurgical practices'. We can quickly agree that they refer to activities outside the scope of sampling and testing. But then, what does the article say next with respect to terms that do affect us?

The Iron Ore Royalty Agreement – Article 5 further mentions: "standard sampling and analysis procedures pre-ailing in the iron ore mining and milling industry." Delegates of ISO Technical Committee 102 for Iron ore and direct reduced iron can surely voice their expert opinions on what could be considered as the appropriate standards for iron ore commodity trading. ISO (not an acronym) is the International Organization for Standardization that develops and publishes international standards that are designed to facilitate equal trade conditions. Unfortunately, here there is no reference in the Article to an ISO or other specific standard, or even to the Theory of Sampling. That would have helped the person that is tasked to do the sampling, moisture-testing and calculation of the DMT, but there is no further guidance in the agreement, not a commercial contract, there is nothing at all on the specific approach to follow when it comes to DMT and the associated sampling and testing. Is this just a bad example? Let's take another look in the repository of Law Insider for a reference to DMT and moisture. In a trade contract for a solid bulk commodity we find for a copper concentrate from a renowned Swiss trader<sup>4</sup>: "Article 9.02 - Determination of Dry Weight and Moisture. The dry weight and moisture as determined pursuant to Section 9.01 shall govern for the purpose of final settlement of the Total Compensation for each Parcel." Again, we are referred to another article in this Swiss trader contract to find the answers that we need, but here we go: "Article 9.01 - General Procedure. (a) With respect to Parcels shipped to Japan, South Korea, the Philippines, North America (including Mexico), or Western Europe (including Bulgaria) hereunder, the weighing, sampling and determination of moisture for each Parcel shall be carried out in accordance with internationally accepted industry standards at the Port of Discharge or at the ultimate receiving smelter in the country, whichever is customary. The Seller and the Buyer shall mutually agree on the person to supervise at these operations, and its costs shall be shared equally. (b) For shipments to China and India, the Seller and the Buyer shall mutually agree whether each ultimate receiving smelter: (i) has available reliable modern equipment; and (ii) applies accepted standards commonly recognized in the industry, for the purposes of weighing, sampling and determining moisture content of a Parcel. If the Seller and the Buyer agree that a smelter does not satisfy both of these requirements, the weighing, sampling and determination of moisture of each applicable Parcel shall be carried out in accordance with internationally accepted industry standards at the Port of Discharge. If, alternatively, the Seller and the Buyer agree that both of the foregoing requirements are satisfied, the weighing, sampling and determination of moisture shall be carried out in accordance with internationally accepted industry standards at the receiving smelter. In either event, the Seller and the Buyer shall mutually agree on the person to supervise at these operations, and its costs shall be shared equally."

Delegates to ISO Technical Committee 183 for copper, lead, zinc and nickel ores and concentrates would know too that there are specific standards that cover the weighing, sampling and moisture determination that can provide a lot more guidance than the same undefined terms that we find in the Swiss contract. It was not just a coincidence: sales contracts very seldom actually specify the standards that will apply. And with more than 20 years of experience in traded commodity inspections the author can state that buyer and seller will seldom agree and actually specify a standard or a theory at any stage in their dealings. It is really left to the person that is appointed for sampling and moisture determination to make his/her own interpretation on what is an 'international standard', or what is a 'prevailing practice'. That is quite subjective unfortunately and it may stem from the insecurity or lack of expertise. It does explain another bold referenced sentence of Article 5... more on this later.

### Three samples

Here we are not going into a quest for more contractual examples; please take my word for it that it is common again that, at least contractually, there is little to no meaningful guidance in commercial contracts on how many samples should be tested for moisture determination. Let alone a specification how many cuts or increments samples should be composited together. In fact, in most contracts the use of the term 'sample' has nothing to do with precision of sampling, but is only used to indicate the number of final split portions obtained by dividing an unspecified mass of sample material at an unspecified nominal top size. In this case the number of three samples corresponds to the parties to whom final samples are to be distributed:

- Seller
- Buyer
- Agent (umpire or referee sample)

Each party would receive only one sample each. This too is typical for sale and purchase agreements for solid bulk commodities where the financial settlement is finalized after both parties have tested their sample for metal content, or penalty elements... Such final samples should be the end result of a representative sampling process, they would be dried, crushed, homogenized and pulverized to a size of about 1/10 of a millimetre... But this is not meaningful at all for moisture determination!

Moisture – or mass loss on drying at a specified temperature in a specified atmosphere (e.g. air or inert gas) – should be determined on test portions that result from a representative sampling process that was done as close as possible to the time and place where increments (or cuts) were drawn from the bulk commodity. In practice it is not possible to pack and protect the integrity of divided sample material that is to be used for moisture determination. Not only is packing and transporting over long distances a concern with respect to loss of moisture, but it is also a cumbersome exercise with respect to the sample mass that is required for transport. In the examples of iron ore, the minimum mass of a single test portion is 1 kg (at 10 mm nominal top size) and as a minimum four test portions are required in case there is a single composite sample for the whole shipment. Therefore, the minimum mass of a divided sample to be dispatched – each of the 'three samples' – should already be 10 kg minimum as per ISO standards 3082 (Iron Ore)<sup>5</sup>. In the example of the copper concentrates where sub samples for each 500 tonnes were agreed the sample mass to be dispatched as per ISO 12743<sup>6</sup> would have been minimum 46 kg (at 10 mm nominal top size of agglomerates) for a 10,000 tonnes shipment. Such sample weights may seem trivial in a world where millions of tons of solid bulk commodities are shipped, but the reality is that the logistics and costs of

shipping some tens of kilograms of sample material by mainstream courier companies is considered as burdensome due to red tape regulatory and documentary reasons. It is also considered expensive in relation to the cost of sampling and testing. All in all: not an option, moisture determination should be done on-site or near-site.



**Figure 1. Samples in their non-absorbent air-tight bags awaiting drying soonest after sampling for best integrity**

Unfortunately, in the contractual agreements for establishing dry metric tonnage, this is not properly addressed. Equally unfortunate is that inspection and laboratory management standards such as ISO 17020 for sampling, and ISO 17025 for testing, are not providing adequate help in my experience either. ISO 17020 and ISO 17025 accreditors often miss the true meaning of the commodity specific guidance that the subject matter experts working in ISO Technical Committees included to reduce risk of moisture bias and it happens that moisture samples of accredited sites still traverse quite a bit of distance and time before being tested. Advise: specify that your moisture samples are tested on site or near-site... and add KPI as maximum distance and time!

### Retain a third sample in the event of a dispute

Retain a sample in the event of a dispute? Retaining a sample for longer periods for moisture determination? Following the last paragraph, where the objections of more or less immediate sample dispatch were already discussed, it is hopefully evident that a longer period of storage would be required here. The third sample will be retained pending testing for moisture by 1. the seller and 2. the buyer, plus a certain time needed for the unsuccessful dispute resolution; this will not do the sample integrity any good. But, for the sake of legal conformity as the contracts refer to international standards after all: we will check one such standard; using ISO 3082:2017 – Iron Ores – Sampling and preparation procedures. Again, just as an example of what specific standards would contain: "ISO 3082:2017 – 4 General considerations for sampling and sample preparation – Basic Requirements: ... Moisture samples shall be processed as soon as possible and test portions weighed immediately. If this is not possible, samples shall be stored in non-absorbent airtight containers with a minimum of free air space to minimize any change in moisture content, but should be prepared without delay." ISO 3082:2017 – 10.2.4 Special procedure for moisture content: "Constitution and collection of moisture test samples for moisture determination shall be such that changes in moisture content are minimized, including measures to minimise the effects of weather (heat, humidity and rainfall) and time (evaporation), and may include the use of special containers and storage conditions. This will minimise bias and result in better overall precision (including sampling, sample preparation and moisture determination)..."

"You see!," the legal teams will now say, "...it is possible! Even the ISO international standard permits what we wrote in our contracts!" Admittedly, in a court of law or in arbitration proceedings it will require persuasion and expertise by looking further than the verbatim of the standard alone. Bear in mind too that the name ISO is derived from the Greek 'isos', meaning equal, and as such aims to ensure that its standards to describe the characteristics of the traded commodities provide confidence that the requirements for those commodities and testing have global relevance and are accepted worldwide. We must look a bit further and investigate context and meaning: ISO 3082:2017 – 10.2.4 "Special procedure for moisture content: ...When it takes a long time for loading or unloading a lot, the lot shall be divided into parts corresponding to not more than 8 h periods. A moisture partial sample shall be constituted representing each part and a moisture determination shall

be carried out. The division into parts shall be subject to weather conditions, e.g. heavy rain or high temperature, and other conditions or circumstances at the time of loading or unloading. However, if the moisture sample containers and storage conditions prevent a change in the moisture content of the moisture partial samples, a moisture gross sample may be prepared for the whole lot..." The intention of ISO is clear, by reference to the 8 h periods it sets the expectations of moisture determination. It shall be done within hours after sampling. Not days or weeks that would be the case by courier logistics of the seller and buyer sample, testing in remote laboratories of seller and buyer, testing for moisture in both laboratories, exchange of results between seller and buyer, unsuccessful dispute resolution, courier dispatch of the third (umpire/referee) sample and ultimately testing at the umpire/referee lab.

If the legal teams would not give up yet and insist referring to text in ISO 3081 mentioning sample containers and storage conditions that can protect the integrity of such important moisture samples, then I want to refer to Ziegelaar and Fritz (2017)<sup>7</sup> that have studied a selection of sample containers. They concluded that well-sealed plastic bags, PVC jars with screw-top lids and even steel paint cans failed their test to preserve moisture... already for relatively short periods. Quantification of moisture losses is very difficult as there are so many variables that impact changes in moisture: ambient temperature and relative humidity just to name two. But, a difference of 0.1 per cent in moisture change is not hard to imagine for a loss over a period of a few weeks. Ziegelaar and Fritz even referred to errors from 0.5 to 1 per cent in moisture and calculated the impact of 0.1% for the Australian iron ore exports in 2017 to make a point. At current pricing levels of iron ore iron and an export tonnage of around 900 Mt/annum that would now convert to US\$ 140M as cost for such a small error. Moisture determination needs to be done on-site, or near site. Immediately after sampling, or within hours after sampling but only provided that the containers and storage conditions are not introducing significant change in the moisture content in such period of hours as it not possible in practice to maintain sample integrity over longer time. It is practically impossible to preserve samples over longer periods of time without compromising accuracy of moisture determination. Consequently, the provisions in the contracts with respect to sampling and to samples have little real use when it comes to moisture determination and calculation of DMT.

### **All statements or reports wherein such independent inspector's assay of samples are set forth shall be conclusively presumed to be true and correct**

Wow! Such high credit and praise to the independent inspector who appears to be all-knowing and with full empowering own discretion of deciding on a sampling plan and a way to test for moisture. A couple of grab increments at a random moment during loading or discharge taken by an ever so popular cast aluminium, round bottom, sugar/flour utility scoop would fill up a couple of moisture trays. Moisture trays with ore that are then put over a gas burner and stirred until the technician considers it as 'dried'.

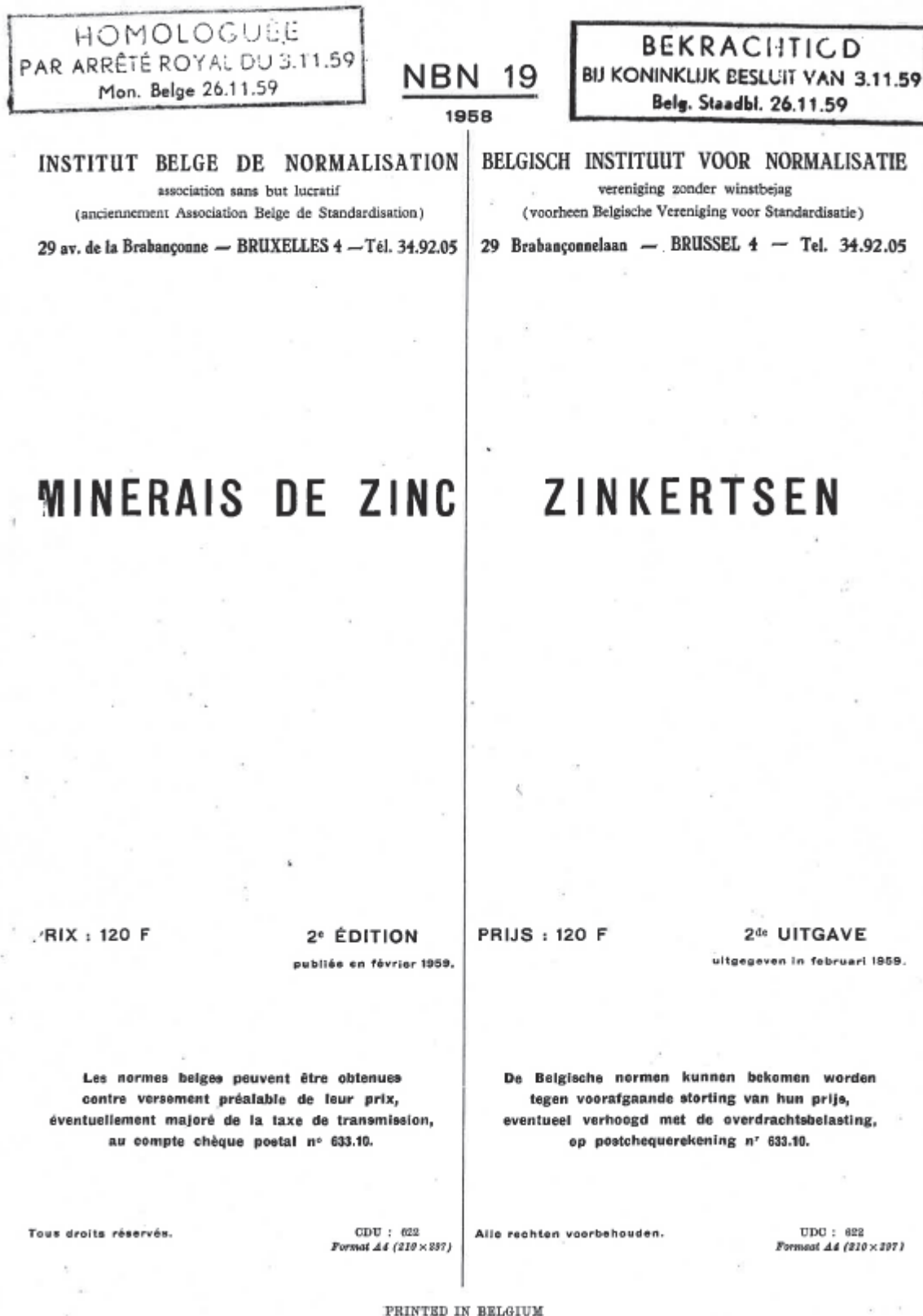

Figure 2. Belgian standard from 1925, reissued in 1959 and still valid in 2022

"Surely that is not a standard practise for solid bulk minerals!", a reader may now exclaim in shock. "No?" Meet NBN 19:1958<sup>8</sup>, a Belgian standard for sampling and testing of Zinc Minerals which contents were first issued in 1925 but remains valid today as official standard for imported zinc ores and concentrates for the sampling and testing of the moisture content. Translated into English with smallest possible liberty and NBN-19:1958 states, bulletized:

- Take all 1 kg sub samples for each of 300 tonnes sublots and spread on a steel plate,
- Pound and mix twice, then form into a square,
- Extract 1 kg taking increments diagonally,
- Crush in a mortar till all passing a sieve with apertures between 2 mm and 3 mm,
- Place into a sample container and seal for transport to the laboratory,
- Moisture content shall be measured in the evening, or latest the next morning,

- Testing will be done by the buyer and with the help of the seller's representative,
- Open the container with the moisture sample [filled with 1 kg during sample preparation process] and transfer the sample to a large copper bowl,
- Spread out evenly,
- The operator accurately extracts a test portion of 100 g using a spatula and places it in a round porcelain enamel dish of 250 ml that was tare weighed earlier to nearest 0.05 g,
- Heat over a Bunsen burner,
- Monitor with a mercury thermometer that is kept in the bulk of the test portion during heating that the temperature will not exceed 100°C,
- Use the thermometer to stir and mix the test portion whilst making sure that no sample material is spilled; this can be checked by cleanliness of the working surface,
- Cut off the burner till pilot light when 100°C is reached and only ramp up again when temperature has dropped to 50°C,
- When the temperature has again reached 100°C the burner is turned off and a cold sheet of glass is placed over the moisture tray that should then not show any condensation, repeat heating process when condensation is noticed,
- Weigh the warm tray and test portion to nearest 0.05 g and heat for one more cycle,
- Re-weigh the warm tray and test portion, the weights should be identical; if not continue with heating and weighing cycles until two successive weighings are identical,
- Record mass of the gross dried test portion and the tray,
- Subtract 1/10 of a gram from the tare weight of the cold tray as this is the correction factor for weighing in hot condition,
- Subtract the corrected tare weight from the gross mass of the dried test portion and the tray in order to obtain the dry weight of the test portion,
- The difference between the 100 g that was initially placed in the tray and the dry weight represents the moisture that was in the sample and is used to calculate the moisture content of the subplot to nearest one-half of one-thousandth.

Using the above as example is very much for purpose of polarization, but it shows what might happen in an extreme case when a contract is followed to the letter and everything is left to the discretion of the inspector. In practice this kind of moisture determination is no longer observed in its entirety in Belgium on zinc concentrates. However, parts of the procedure such as pounding of the sample, mixing it and forming a square are for example. Also, for other materials such as ferro alloys, stainless steel scrap turnings and occasionally even on industrial minerals a similar heating procedure and drying over a Bunsen burner is still observed sometimes at locations without suitably equipped sample processing facilities, or where receivers do not mind preparation error of losing some sample material and inflating the moisture content. The point in case: specify the testing method! Define the mass of the test portion in relation to the particle size, state the temperature of drying, mention the atmosphere of drying and the endpoint of the test. This does not have to be too detailed. The following may suffice: "Test portions of 1 kg and sample material of max. 10 mm nominal top size shall be dried in air in a suitable oven at 105°C ±5° until constant mass is reached between two successive weight determinations and recordings of the dry mass; 4 hours apart. Constant mass is achieved when the two successive do not differ by more than 0.05% of the initial wet mass of the test portion." Without such definitions and agreements, it is a pretty big step to contractually agree that everything the independent inspector says is true.

Trueness of the reported moisture value will require that the tested sample is the output of a representative sampling process and that during the sample preparation nothing is added to the sample... or removed from it. Sampling and its representative process is not given much attention in the example contract Iron Ore Royalty Agreement, neither in the copper concentrate contract of the Swiss trader. Nothing on the number of increments of cuts by the mentioned "available reliable modern equipment", we will have to hope for the best that the "sound mining and metallurgical practices and standard sampling and analysis procedures prevailing in the Iron Ore mining and milling industry" will deliver. That might be a bit too much to hope for unless each of such practices and standards find their foundation in the Theory of Sampling (TOS). In fact, would that not be the best provision in any contract: "Sampling shall be in compliance with TOS"? No need to refer to undefined approaches and practices or to modern [what is it?] equipment, but to a comprehensive authority to resolve such uncertainties and undefined references. TOS is there to tackle all issues with respect to correct – and incorrect sampling, bias, precision and representativity; it is further detailed in four fundamental publications<sup>9, 10, 11, 12</sup>. Remember: TOS is not commodity specific! TOS can be applied across the board if implemented by a knowledgeable specialist who understands it as well as the commodity in question.

Back to "samplewashing" as this was the term used in the opening sentence of this paper. Let's for the purpose argument assume here that TOS was followed and that the sample is the end result of a representative sampling process. A process where heterogeneity and target precision were duly considered and where the airtight containers that were used, to preserve the sample integrity during transport and storage, were flawless. It was detailed already in this paper that maintaining the integrity of a moisture sample over longer time is not practically possible, but even if it were: then still all diligent efforts of sampling and packing samples can be washed away by incorrect sample preparation and testing.

We will go through the process steps sequentially, but first remember what the basic requirements for sample processing are. Most sampling standards that describe sample processing start with a variation of the below, this is from ISO 3082: "ISO 3082:2017 – 4 General considerations for sampling and sample preparation – Basic Requirements: The basic requirement for a correct sampling scheme is that all parts of the ore in the lot have an equal opportunity of being selected and becoming part of the sample for analysis (Gy; Pitard). Any deviation from the basic requirement can result in an unacceptable

loss of trueness and precision. An incorrect sampling scheme cannot be relied on to provide representative samples..."

First step, after sampling and storing moisture samples in non-absorbent airtight containers with a minimum of free air space, is to obtain a test portion from these samples. Therefore, the sample container must be emptied again. Often condensation is formed on the inside of the container during transport and storage. If not mixed back into the sample, or when not quantified by drying of the container itself after emptying it, then something – a mass of water – is excluded from the sample at that stage. This is preparation error, when it happens the reported moisture will likely be lower (than a situation without preparation error).

For some bulk ores, there can be a comminution step as the particle size is too large to accommodate oven drying. ISO 3082 states for iron ore that the nominal top size of the moisture test sample shall be 31.5 mm or less and that samples larger than 31.5 mm shall be crushed first. The standard does warn that the sample may be pre-dried – in its entirety – when it is difficult to conduct crushing and dividing owing to a sample being adhesive or excessively wet. "Oh, oh," we now even find vague, undefined conditions in the standard by the very ISO technical committee that I am part of myself. To completely avoid an unquantified loss of moisture due to heat generation of crushing, or wet adhesive particles left behind in the crusher pre-drying whilst weighing the wet and pre-dried sample: it really is the best approach to vigorously follow TOS and avoid all incorrect sampling errors. But it comes at a price, literary. To accommodate pre-drying, sample preparation facilities must have space, a lot of space to spread out uncrushed sample material and allow it to air-dry and equilibrate to the ambient conditions. The mass of the uncrushed sample that should be subjected to pre-drying is large: at 40 mm nominal top size table 4 in ISO 3082 gives an example of minimum 325 kg. If – as is the case in most sample processing facilities – multiple successive samples require processing in immediate, or short succession then this can become a serious bottleneck very quickly. With floorspace of sample preparation often not being much more than an ordinary office space in an available building, typically only one sample can be processed at once.



**Figure 3. Sample immediately after crushing (during sample preparation), pre-drying was not possible and moisture loss has likely occurred**

There is often no space for more samples, and it would be too much of a risk of cross contamination when successive samples would be spread out closely adjacent on the floor for air-drying and left uncovered for the time that such pre-drying requires. So, what is done in practice around the world? Here we inevitably come a point to consider what is available for sample processing on-site or near-site? The only option is to apply a best effort with the available drying space and processing equipment whilst using the wording such as "being adhesive or excessively wet" as found in ISO and some other standards as an escape clause and decide that samples are not too adhesive or too wet... and continue with crushing to 31.5 mm, or smaller, to a mass that will simply fit into the available drying space. When comminution is required on the sample that is used for moisture determination there is again risk that some sample with high moisture content is lost: this is preparation error and the reported moisture will likely be lower.

Except at limited locations where there are facilities with mechanical division, there will also be a step of mixing. This is an attempt to homogenise the sample and to aid extracting of test portions, because there will be segregation as a result of the compositing of the sample by individual cuts or increments, i.e. from the quality variation of the product itself. But there can also be segregation caused by the time and conditions of sample store in the container, referring to condensation again as perhaps the most imaginable one. But how to mix a sample of a bulk solid material without loss of moisture due to airflows



and evaporation? ISO 3082 will even prohibit mixing despite an obvious need in case of segregation; it states that mixing of moisture samples may result in moisture loss and hence bias, so moisture samples shall not be mixed prior to division. ISO 12743 is clear too by stating that moisture samples shall not be mixed prior to division, unless mixing is carried out in a closed container, such as a plastic bag. The differences between the two ISO standards are a result of the different commodities iron ore vs. non-ferrous concentrates. This is not because TOS provisions are different, but because the sampling and sample preparation conditions are different. The sampling and preparation conditions are designed towards the tonnage and volume processed at the place of sampling. ISO 3082 considers very large lots over 340,000 tons. ISO 12743 does not specifically consider the tonnage of shipments, but in practice a shipment is seldom more than 10,000 tons. The standards in the industry are designed by representatives from the industry and as a result include specificities of respective conditions. As industry standards and ISO are primarily there to accommodate equal trade it may thus happen that TOS takes the backseat. When it comes to moisture, that has such a significant impact on the money that changes hands: this is a potentially expensive oversight.

And then there is division, or extracting, into the actual test portions. As was covered above, it is practically impossible to pre-dry samples in their entirety, the same applies to 'full drying' and moisture determination on the entire sample. In most cases a sample must be divided into test portions that can be accommodated by the availability of moisture trays and fitted into the drying ovens. Like the installation of a sampling system is often an afterthought of engineers when designing a terminal, sample preparation facilities with appropriate drying facilities meet the same limitations. As a result, drying is not tailored to the conditions and properties of the samples, but it is the other way around and test portions are shaped in size and mass to fit into the oven space and maximum allowed time for drying. When it comes to moisture determination it is not only the weight of the test portion that may enable a sample preparation process to maintain its representativeness from correct sampling error perspective. Much more important is that there are no incorrect sampling errors introduced from division techniques where airflow causes evaporation.

Finally, after obtaining the test portions we are ready for the actual testing. That should be pretty much straightforward, "yes?" Weigh, stick it in the oven till dry, weigh again and express the loss of mass as percentage of the initial mass of the test portion... Well "yes" indeed, but mind your steps:

- moisture trays should pre-weighed clean and dry, made from non-corrosive material
- balance for weighing should be of sufficient size to support the moisture tray,
- test portion should be spread out as a thin layer of few or single particle thickness,
- drying temperature should be as agreed, or specified
- drying time should be sufficient, but not too long; especially when material may oxidize, sublime, or lose volatile elements / hydrated water
- end-point should be defined, what is constant mass exactly?
- test portions shall weighed immediately after drying when they are still hot, or allowed to cool in a desiccator only
- balance for weighing should have a heat protective barrier so that loadcell(s) are not influenced by hot moisture trays
- preferably the same material tested for moisture should be used for further chemical analysis too (as common sample)

All in all quite a bit of detail eh? And in the contract there is this: "All statements or reports wherein such independent inspector's assay of samples are set forth shall be conclusively presumed to be true and correct." Of course, the independent inspector is expected to be competent and suitably equipped with all the tools to perform its job without introducing bias or impacting precision. It is just that differences in comminution (or not), division techniques and to what mass, time of drying and end-point definition can have a significant effect on the trueness of the final moisture assay. Especially when considering the overall precision for moisture for the two example commodities of iron ore and copper concentrates when following the respective ISO standards.

**Table 1. Target typical overall precision as absolute percentage for moisture  $\beta$ S<sub>PM</sub> or  $\beta$ T.**

Commodity	Mass of lot t								
	Over 270 000	210 000 to 270 000	150 000 to 210 000	100 000 to 150 000	70 000 to 100 000	45 000 to 70 000	30 000 to 45 000	15 000 to 30 000	Less than 15 000
Iron Ore	0.34	0.35	0.37	0.38	0.40	0.42	0.45	0.49	0.55
Copper Concentrate	0.6								

A target overall precision between 0.34% and 0.6% absolute... and that is for standards that are prescriptive when 'minding our steps!' For outdated yet arguably still legal, or regulatory standards such as NBN 19:1958 that will obviously not be the case; just to list a few reasons:

- evaporation during spreading and pounding = Preparation Error
- evaporation during mixing twice (how?) and spreading into a square = Preparation Error
- segregation after spreading into square = Quality Variation
- diagonal extraction of increments (how many and how much) into a 1 kg sample = Delimitation Error, Extraction Error & Preparation Error
- Fixed 'correction factor' of effectively 0.1% due to weighing hot sample trays...

## Demanding an assay by an independent referee [in case of disputes]

Actually, this paper already touched on the futility of demanding a moisture re-test. Samples for moisture cannot be easily preserved over time and losses are likely to occur, especially over prolonged periods. It is expected that at least days have lapsed since the actual sampling and division of samples into moisture test portions. I will not dwell on this again at this stage. What is most interesting though, is that suddenly, the sample is considered absolutely true and representative of the cargo and material it was taken from!

Seller and buyer have a dispute on the moisture content, or DMT, but contractually look at the last little step of testing only. Albeit this last step is of course important and not devoid of its own problems as demonstrated above, the last step is what it is: then end of a process. In case of dispute on DMT not only the last step, but the whole process should be reviewed, the weighing and sampling first, then preparation and ultimately the test methodology itself. If a dispute is settled by just repeating the moisture test we can actually say with great confidence that TOS is thrown overboard: preparation errors are likely as moisture would have been lost since sampling and the most important scrutinizing of the sampling process is simply not considered at all. So: once a sample was generated, by whatever procedure deemed adequate, it becomes the contractual holy grail. Even when such process was flawed or erroneous, there is little contractual recourse possible. If that is not 'samplewashing' then I do not know what is! Mis-leading information on and of the sample is used to gloss over bad behaviour of non-TOS sampling and erroneous testing. Samplewashing!

Retrospectively it is not easy to repeat the process of weighing, sampling and moisture determination:

- it is difficult to demonstrate integrity of the material since it was weighed, sampled and stockpiled
- it is cumbersome and expensive
- and without TOS compliant standards... how?

For several reasons, but in practice there is only one time that DMT can be truly determined. That time is when the commodity changes ownership and the weighing sampling and moisture determination is performed right there and then. At that time and place the sampling should follow TOS and that is what should be contractually agreed to avoid disputes at later stage.

## Conclusion

For commercial transactions of solid particulate commodities, the pay metal content is needed. It requires the moisture free mass, or dry metric ton basis. Which in turn requires sampling and testing for moisture determination. The problem is often that the procedure and theory for such sampling and testing are not contractually agreed or de-fined. Ultimately, in case of differences between interventions at different locations, there can be disputes. The disputes are most likely a result of a sampling methodology that is erroneous: where incorrect sampling errors were not completely eradicated and/or where correct sampling error was not sufficiently mitigated. However, in case of a dispute on DMT, in practice, only the moisture test is repeated on the erroneous sample. Even when flawed and stemming from bad behaviour, or when the sample integrity was compromised because moisture would have been lost, that sample still would be used to for commercial moisture determination and its result considered final and true. To glance over errors... and still use an outcome as true: that I can only call samplewashing.

The solution to this is the same message that you will have heard before. It is the same message when discussing installation of a sampling system when this is done as an afterthought in an existing port infrastructure. The message: do not forget to define a TOS compliant standard from the earliest stages! When designing a port, terminal, or warehouse and sampling is part of the workflow then it solves a lot of problems to set things up properly from the beginning. Ultimately the effort at the onset will result in cost savings for not having to make major modifications to logistics or sampling solutions. Or cost of being wrong, making ill-informed decisions, or trading on the wrong values. Perfectly in line with this reasoning is contractually agreeing on the moisture determination method itself and making sure that also here all incorrect sampling errors are removed and only correct measurement remains.

## ORCID iDs

D. Aldwin Vogel: <https://orcid.org/0000-0003-0445-5259>

## References

1. IndexMundi, Commodities Glossary - Dry Metric Tonne Unit, 2022 <https://www.indexmundi.com/commodities/glossary/dry-metric-tonne-unit>
2. Law Insider, Iron Ore Royalty Agreement, Undated <https://www.lawinsider.com/contracts/7NwhSRadzOc>
3. Vogel, D.A. & Esbensen K.H., *WHAT are sampling errors—and WHAT can we do about them? Part 2: Sampling and weighing—different, but the same...*, Spectroscopy Europe, Journal article, 2021-04-13.
4. Law Insider, *Copper concentrates sales agreement among Louis Dreyfus Company Metals Suisse S.A., and Terrane Metals Corp., and Thompson Creek Metals Company Inc.*, 6 May 2016 <https://www.lawinsider.com/contracts/8Aw9e5qsvH7>
5. International Organization for Standardization, 2009. *ISO 3082:2009, Iron ores – Sampling and sample preparation procedures*, p. 10, 11, 40.

6. International Organization for Standardization, 2021. ISO 12743:2021, *Copper, lead, zinc and nickel concentrates – Sampling procedures for determination of metal and moisture content*, table 6.
7. Ziegelaar, B. & Fritz, M, *Sampling for the percentage moisture in the iron ore industry*, proceedings Eight World Conference on Sampling and Blinding, Perth 9-11 May 2017, p. 273.
8. Institut Belge de Normalisation, 1959. NBN 19:1958, *Minerais de Zinc 2e Édition*, Imprimerie Hayez, s.p.r.l., Brussels, Belgium
9. Dansk Standardiseringsrad, 2013. DS 3077:2013, *Representative sampling – Horizontal standard* <https://webshop.ds.dk/en-gb/subjects/standard/ds-30772013-1>
10. Esbensen, K.H., *Introduction to the Theory and Practice of Sampling*. IMP Open, Chichester, UK (2020). ISBN: 978-1-906715-29-8. <https://store.impopen.com/en/sampling/introduction-to-the-theory-and-practice-of-sampling.html>
11. Pitard, F.F., *Theory of Sampling and Sampling Practice 3rd Ed*. CRC Press, Taylor & Francis Group (2019). ISBN 978-1-138-47648-6 <https://www.amazon.com/TheorySampling-Practice-Third/dp/113847648X>
12. Lyman G.J., *Theory and Practice of Particulate Sampling: an Engineering Approach*, Materials Sampling & Consulting Pty Ltd. <https://materials-sampling-and-consulting.com>

## Case study - Improved sampling of iron sludge at Glencore Nikkelverk

Eirik Djuve<sup>a\*</sup> and Elke Willam Thisted<sup>b</sup>

<sup>a</sup>Glencore Nikkelverk AS, Vesterveien 31, P.O.boks 604, 4604 Kristiansand, Norway. E-mail: [Eirik.Djuve@glencore.no](mailto:Eirik.Djuve@glencore.no)

<sup>b</sup>Glencore Nikkelverk AS, Vesterveien 31, P.O.boks 604, 4604 Kristiansand, Norway. E-mail: [Elke.Thisted@glencore.no](mailto:Elke.Thisted@glencore.no)

Glencore Nikkelverk produces nickel, copper and cobalt with high purity. This demands several leaching and filtration steps removing contaminants to achieve a high-quality metal via electrolysis. In one of the process steps iron is oxidized to its trivalent state and forms a slurry precipitate, which contains different iron components described as  $\text{Fe}_x\text{O}_y(\text{OH})_z$ . The slurry is very fine-grained, corrosive and has a consistency resembling muddy clay. Filter presses with up to 90 frames separate the process solution from the iron slurry, which undergoes a washing cycle. Due to the slurry's fine-grained nature, this washing cycle is challenging with uneven distribution of the washing water and results in loss of valuable dissolved Nickel chloride ( $\text{NiCl}_2$ ) which is left in the slurry. The slurry discharges of the filter presses are stored in Nikkelverk's underground landfills and leads to a yearly loss of approximately 20 million Norwegian kroner. In 2017, the R&D department at Nikkelverk took spear samples for over a period of nine months to map the Nickel content in the material prone to be discharged to the underground landfill. The results showed that the Nickel lost was approximately 40% higher than reported from the samples taken directly from a frame by the operators. In 2018, a mapping of several press frames by handheld X-ray analysis showed that the Nickel content, depending on the position of the sample taken in a frame, varies. Since the physique of the operators determines where the sample is prone to be taken, this will add to the variation in the analytical result of Nickel lost. It can be assumed that this variation completely overshadows the process variation resulting in lost Nickel. In summary, the current sampling protocol gives a high variation and a wrong content of Ni in the slurry. Nikkelverk's commitment to its business system and thereby involvement of resources on any level of the company has resulted in formations of process teams which shall approach such issues and find solutions fit-for-purpose. Therefore, a process team was initiated to develop an automatic sampler in-house for the iron slurry. Their goal was to achieve samples that are more representative as the ones retrieved by today's protocol. There are six filter presses where slurry is separated from the filtrate. Each filter press releases its slurry on a conveyor belt, which transports the slurry to a collecting chute. The idea is to mount an automatic sample in the collecting chute prior to the slurry compiled for transport to the underground landfill. The article will describe in detail the pre-studies of the problem, the development of the automatic sampler for the collecting chute and discuss its conformity regarding the theory of sampling.

### Introduction

Since 1910 Nikkelverk has refined, produced, and exported nickel and other metals from the production plants in Kristiansand. The environmental, energy and process technology used at Nikkelverk has made the plant one of the most effective and technologically advanced refineries in the world. An important part of the extensive value chain in the Integrated Nickel Operation, it is of the utmost importance to handle the intermediate raw materials responsibly and avoid losses at the refinery. Achieving a high material yield is desirable both from an economic and environmental point of view. It is also vital to reconsider traditional waste streams occurring during production. If properly managed regarding specifications, waste from one company can be of value as raw material for another. When striving for a sustainable operation to serve social, environmental, and economic purposes, one goal must be to revise existing sampling procedures and check their conformity towards the theory of sampling (TOS). This is both valid for physically withdrawn samples and sensors representing process analytical technology. Any kind of sampling in the process industry should be fit-for-purpose, representing the actual condition of your operation. Only then one can place confidence in the resulting data and the decisions made upon them ensuring a sustainable production.

During the last century Nikkelverk has developed towards a highly technological company through engaged staff and high competency in several disciplines. Productivity tools like Six Sigma and Lean were applied to systemize work and utterly improve performance of the process. To achieve maximum efficiency, both in terms of staff performance, management and processes, concepts on how to organize improvement work developed further. The latest productivity tool currently used at Nikkelverk, Nikkelverk Business System (NBS), encourages to form temporary working groups of employees from different areas and with different backgrounds to solve identified problems. The investigations and planning on the automatic sampler described in this paper were done in such a group.

## Background

At Nikkelverk, the sulphide-based matte is processed in several leaching and purification steps to high purity metals needed in a modern society as simplified illustrated in figure 1. Impurities are separated from the nickel containing filtrate by precipitation. It is important to keep process parameters at an optimum to ensure maximum output of metals in the filtrate..

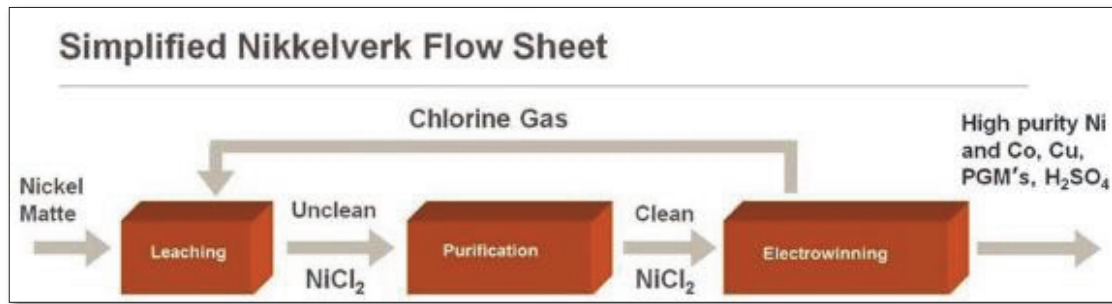

Figure 1. Simplified flow sheet for the Glencore Nikkelverk production process.

Separation of the filtrate from the precipitate is mainly done using filter presses. The filter presses are filled with the liquid/solid mixture, and thereafter pressure is applied to remove the liquid phase to be sent to the next process step. The remaining solid phase undergoes a washing cycle with water to remove the remaining liquid phase containing metals for production. When completed, the press frames are emptied sequentially on a conveyor belt, the content is collected in the basement and transported to a storage facility, figure 2. Depending on the content of the solid phase, it is either returned to a prior process step or stored at the disposal site. Samples taken from the solid phase of each filter press whilst emptying, indicate the performance of the washing cycle.

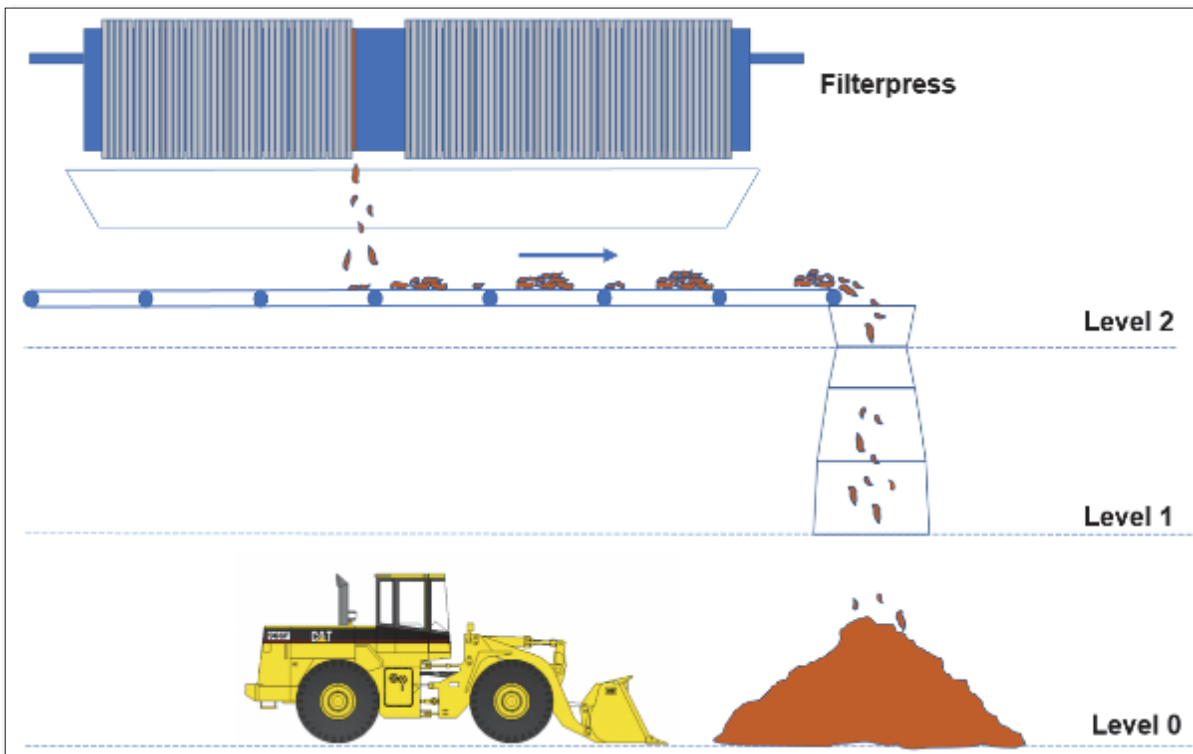

Figure 2. Schematic diagram of emptying a filter press and transportation of solid phase to the storage facility.

In the process step where iron sludge is removed from the process stream several filter presses are in operation. Each filter press contains over 90 frames with a height of 180cm and a width of 100cm of the filtration surface. Though presentations on the internet from filter press suppliers show an evenly distribution of the liquid/solid mixture, the filling of a filter press with iron sludge will certainly lead to a heterogeneous filter cake for each frame and for the whole press. The current sampling routine is done manually by taking samples on one of the frames of the filter press frame chosen by each operator. The press frames are emptied on a conveyor belt and the total content of the filter presses is transported to a storage facility. The manual sample of an arbitrarily chosen frame is most likely taken from the region marked with the red frame in figure 3. Operators take a piece of the sludge from the filter press frame as shown in figure 4, and in addition to bagging a lab sample, they often take a conductivity test. This is done by mixing a fixed amount of sludge and water, using a kitchen hand-mixer. The conductivity of the resulting solution is measured using an inductive conductivity meter. The conductivity comes from water soluble salts in the iron sludge which is mainly based on  $\text{NiCl}_2$  in the sample. Therefore, this indirect measurement serves as an indicator of the remaining Nickel content in the sludge and can help operation to adjust parameters in the filtration process.



**Figure 3.** One of the filter press frames with iron sludge. The red framed area marks the most likely reachable region for the manual sample taken by the operators.



**Figure 4.** Manual sampling from the filter press frame.

### Studying and understanding the problem

The sludge samples, originating from grab sampling, are sent to the laboratory, and analyzed by XRF to determine their Nickel content. During an arbitrarily chosen two years' period, the resulting Nickel content shows a relative variation of 110% ( $u = 2$  std), figure 5. This indicates either that the process is not under control or that the samples taken are not fit-for-purpose where the latter might be the most relevant issue to look at first.

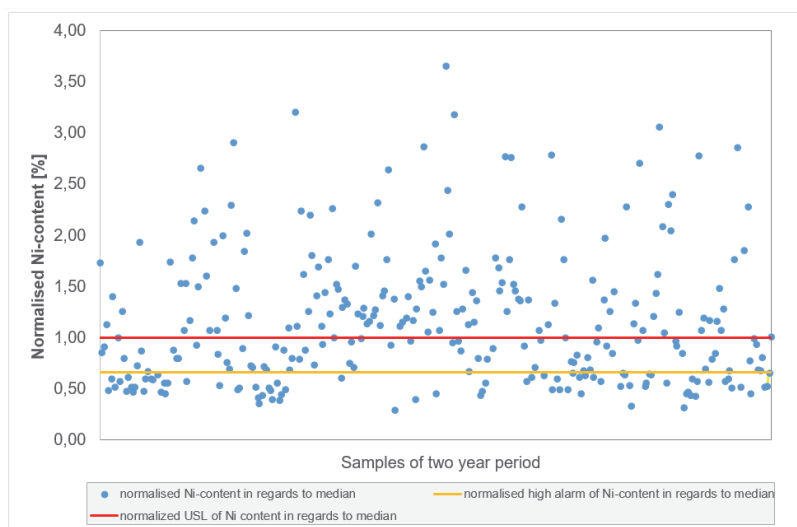

**Figure 5.** Normalized Nickel content compared to median over a period of two years.

Apart from the probable issues during filling and cleaning of the filter sludge in the filter press, there exist a certain likelihood that during the water wash cycle channels are formed where the water can easily go through the filter cake without washing all of the sludge content in the frame. Independent of the root causes leading to this event, it increases the variation of Nickel content from frame to frame.

A sample taken from an arbitrary filter press frame represents the Nickel content of the whole filter press with over 90 frames. Since the position of where to withdraw the sample was not standardized in the beginning of investigating the sampling problem, an additional contribution to the large variation could be assigned to the different height of the operators determining where it is most comfortable to take a sample. Additionally, sampling is usually done by hand with protective working gloves which are also used elsewhere in the process and can at times be contaminated with Nickel salt. This raises the concern that samples are unwillingly cross contaminated and wrongly contribute to the increasing variation in the resulting Nickel content. As recent as February 2022, a procedure for manual sampling was introduced. This helps the situation somewhat by ensuring that the sample is always taken from the same couple of frames, and it also emphasizes the use of clean gloves to avoid contamination.

### Investigation of the filter cake content 2017/2018

In 2017, an attempt was made to determine how much Nickel was lost to storage by investigating the Nickel content in the sludge pile at ground level (Level 0, figure 2). Spear samples from the storage pile were removed over half a year and the results were compared to the corresponding, manual grab samples from the filter press frames. The same analytical method at the main laboratory was used for both sample types to determine the Nickel content.



**Figure 6. Illustration of spear sampling the iron sludge pile at ground level.**

The comparison showed that on average approximately 25% more Nickel was lost to storage than registered via the standard operating procedure with grab samples from the filter press frames. Though spear sampling might not give a fully representative answer<sup>2</sup>, the results indicated that the current sampling grab sampling procedure do not represent the actual content of Nickel in the sludge, figure 7.

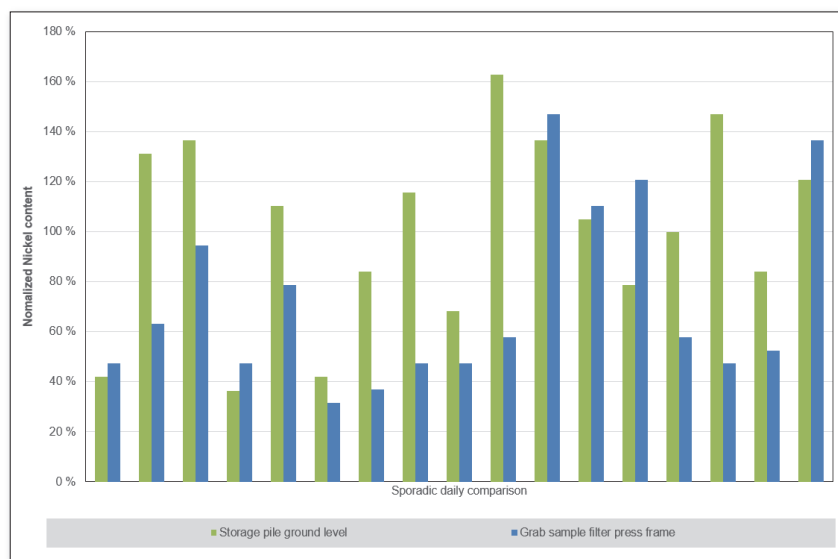
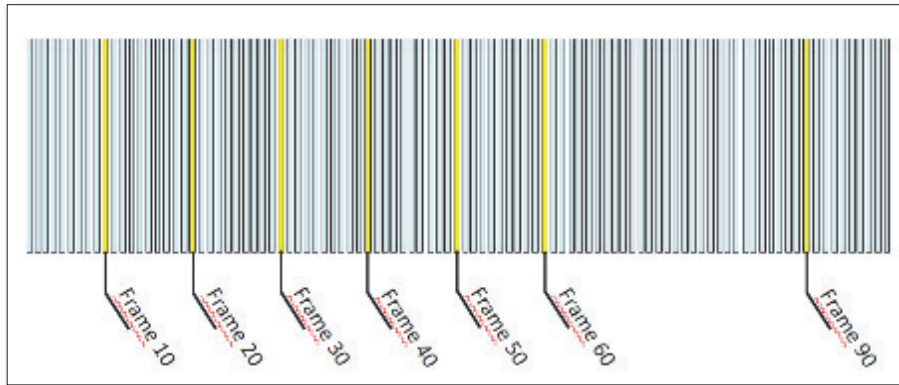

**Figure 7. Comparison between grab sampling filter press frame vs spear samples storage pile over half a year, normalized according to the average of each sampling series.**

In May 2018, another investigation was undertaken to prove the heterogenous distribution of the Nickel content and map the distribution of Nickel in selected filter press frames. Suppliers of filter presses present the filling procedure as an operation where

slurry is distributed evenly on the whole frame<sup>6</sup>. However, in reality the sludge will be affected by gravity and fill from the bottom up rather than distribute the sludge homogeneously over the filter frame. Since there can be deviation from an optimal washing and airdrying cycle of the filter press, Nickel might be more prone to remain in certain parts of the frame.

It was planned to measure the sludge in the filter press frame directly before discharge to the conveyor belt. A handheld X-ray instrument (HH-XRF) from Niton, XL3t-GOLDD+ from 2018 with an Ag-Xray tube and an SSD-detector was used. The most appropriate program on the instrument was chosen. This was the mining programme with four separate programs analysing the sludge sample for 30 seconds for each program, determining the elemental content ranging from heavy to light elements. The total analysis time is two minutes and makes it challenging to keep the HH-XRF at its position on the frame. Additionally, several positions on the frame should be analysed qualitatively, preferably five to six positions, which challenged the need to free the filter press for production purposes. Therefore, on site, another strategy was chosen, where physical grab samples from the filter press frames were placed on filter press clothes placed aside to reproduce their actual position. This secured both continuous production and enough time to analyse the samples withdrawn from the selected filter press frames.



**Figure 8. Illustration of the sampled filter press frames selected for more thorough analyses of the distribution of the Nickel content.**

Seven filter press frames were chosen as shown in figure 8 and for each frame samples were placed approximately on the place of withdrawal, figure 9 and 10.

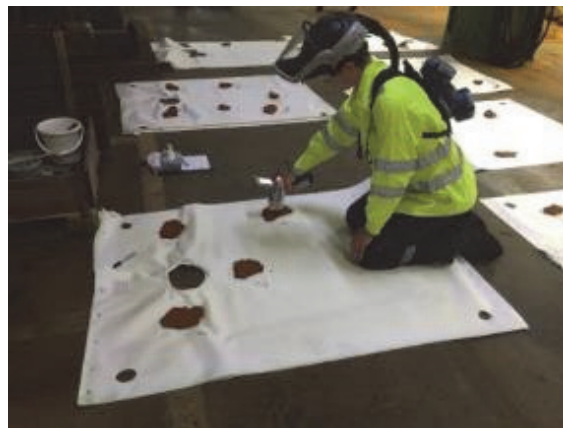

**Figures 9 and 10. Samples positioned on filter press clothes for each frame selected for more thorough analyses of the distribution of the Nickel content with HH-XRF.**

Depending on the element to be analysed one must consider if the element to be analysed is properly represented in an x-ray context. For Nickel, as one of the heavier elements the periodic table of elements, the penetration depth in the sample should be sufficient. As the filter sludge containing mainly a type of iron hydroxide, the matrix of the samples is considered medium heavy. However, the penetration depth of X-rays is theoretically calculated to be only a few millimetres in this matrix which cannot ensure a proper presentation of the Nickel content in the whole sample. Nevertheless, it should be kept in mind that the main goal of the investigation was to prove that there exists an uneven distribution of Nickel in the filter press frames.



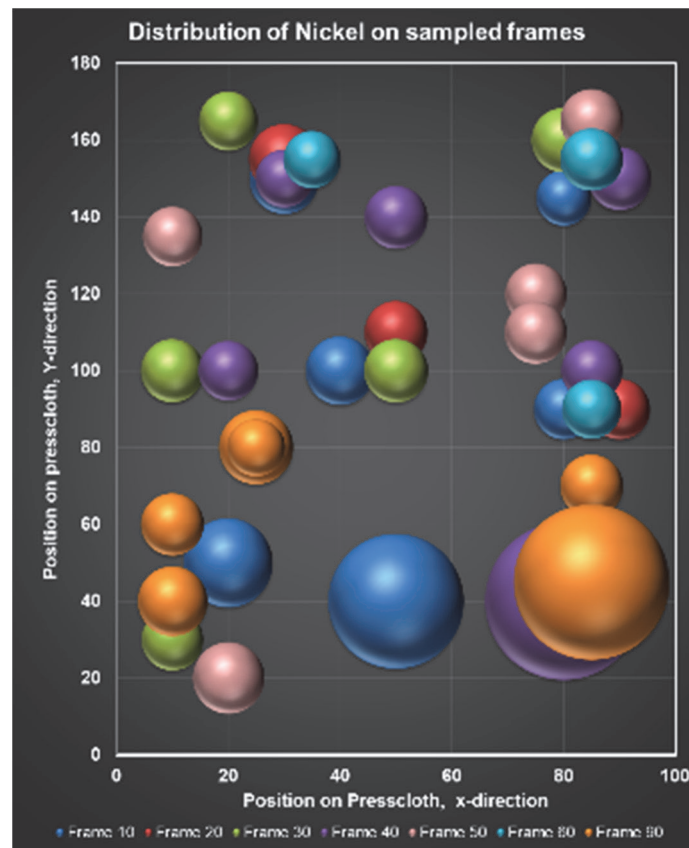

**Figure 10. Illustrated distribution of the Nickel content in seven filter press frames. Size of circles is related to the Nickel content.**

There are hotspots of high Nickel content at one corner bottom of the frames at the day of sampling, figure 10. The root cause(s) could be the washing cycle procedures and so forth. It is expected that minor Ni-components, which are not water-soluble, will not be removed from the sludge. However, efforts are made to reduce the loss of Nickel in the sludge to the absolute minimum. To achieve this, the control measurements of Nickel content in the sludge must be improved. An automated sampling system is planned to be installed where the conformity towards the theory of sampling (TOS) must be considered.

### How to plan a sampler from scratch

According to NBS, a process team was formed with shift operators, mechanical and project engineers as well process metallurgists and electric and instrument engineers on request. Their expertise on the process, material to be sampled and mechanical components was assumed to be sufficient to build a robust automatic sampler. It might seem as an ambitious and maybe even imprudent assignment to plan a sampling system from scratch with inhouse resources. However, one must understand that Nikkelverk has had several mediocre experiences with external suppliers over the years, promising plug and play solutions and resulting in equipment with insufficient performance, extended workload on our inhouse resources and thereby lost value for the company. The main reason for failure of purchased equipment from suppliers is probably the unusually corrosive solutions and sludges being processed at Nikkelverk, which require very robust equipment made of corrosion resistant materials. Therefore, a determined attitude developed over the years to primarily fix issues and challenges mainly with own resources. The Nikkelverk business system also encourages to engage people from several disciplines to solve such problems together as a team. This gives each team member the chance to broaden their knowledge on other areas and motivates them to contribute to a sustainable solution. When implementations of solutions show better results for process control and so forth, the team will additionally be rewarded with a proud feeling having contributed to improved performance of their company. Unfortunately, the team had close to zero knowledge of TOS and had to rely on past experiences and common sense instead. This is obviously affected the samplers' conformity to TOS.

Considering the development of a sampling system for the iron sludge, several workshops and brainstorming sessions in the process team were held to understand the scope of the problem and the challenges involved. Many ideas were discussed, but two possible concepts were considered more thoroughly. The first solution was a sampling device cutting through the falling stream back and forth. This idea was considered to be the least viable, since the discharge chute had to be reconstructed to fit the sampler. The second idea resembled an input feeder which is a well-known technique for transportation of materials at Nikkelverk. Placing it across part of the falling stream seemed to be more robust and easier to implement than the first solution. Emphasis was on the flow behaviour of the material and practical issues involving sample extraction and the functional reliability of the new sampling equipment. In the initial stages, less thought was given to the representativity of the samples extracted representing the sludge content of one filter press. This is mainly because the slurry is sticky and corrosive, so creating a robust and reliable automatic sampler in such an environment is hard. If the sampler works well also gives a more representative sample than before, this would already be a great success and a hard enough challenge even though there is still much more potential for increasing the representativeness of the sampler. The idea considered was a tube placed across the discharge chute as shown in figures 11 – 13.

Placed in a fixed position in the falling stream of the iron sludge, an opening on top of the tube going over the whole length of the falling stream, should ensure that parts of the discharge were collected. The extraction of the sample from the tube was planned to be done with a piston pushing “increments” towards the end of the tube and into a container placed beside the chute.



Figure 11. Picture showing the discharge chute for the iron sludge.



Figure 12. Illustration of planned automatic sampler with collection container besides the chute.

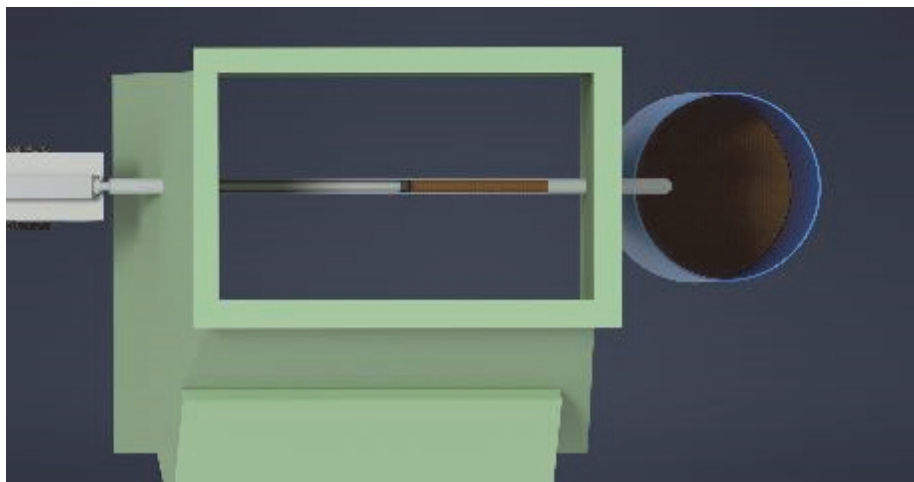

Figure 13. Top view on the planned automatic sampler with collection container besides the chute.

Prior to implementing the complete sampling system, manual tests are planned to check if the concept will work properly and manages to extract parts of the falling stream during the filter press discharge operation.

### The chosen sampler's conformity to TOS

As shown in the previous sections of the paper, substantial work has been done to prove that the previous sampling procedure was unfit and had to be redesigned. In the previous section the chosen sampling system design was presented which shall be compared to the principles of the theory of sampling. As for any sampling and reduction system, one has to know all possible errors which can occur. There are errors due to the material, the process, and the sampling system itself. As stated in the literature and courses related to TOS<sup>3, 4, 5</sup>, the first thing to keep at a minimum – and optimally avoid – are the incorrect sampling errors due to the sampling system, which are the increment delimitation error (IDE), the increment extraction error (IEE), the increment preparation error (IPE) and the increment weighing error (IWE).

#### Increment delimitation error

Since the mass stream consists of a slurry, preferably with low liquid content, the material will agglomerate in large lumps. The size of the lumps may depend on size distribution of individual particles, chemical composition, and solid fraction among others. Hence, there might already be a correlation between the flow properties and the parameter that should be measured. As a consequence, one shall expect a variation in the Nickel content of the slurry leading to a bias in the result. Therefore, designing an equipment that maintains the equiprobability principle is important. Each particle in the mass stream has to have the same likelihood to be sampled. The proposed design, figure 12 and 13, extracts samples only at a fixed position and violates thereby the equiprobability principle. Ideally, the sampler should cut through the entire falling stream at a constant speed and keep the geometry of the cut constant to avoid or at least minimize the IDE – strike 1 for the chosen sampling design.

#### Increment extraction error

Next, the sample must be extracted correctly to minimize the IEE. It is important that the rule of the centre of gravity is followed and thereby ensures that all fragments can fall randomly on either side – into or outside the sampler. Since the slurry lumps have a maximum diameter of about 5-6 cm, the cutter opening shall ensure that the largest fragments can be collected as well. A rule of thumb is to have a cutter opening at least three times larger than the largest fragment of the increment i.e. at least 15 to 18 cm in the case of the planned sampler. As for the current setup, the cutter opening of the sampling tube has a width of 2,9 cm (see figure 14) which means that lumps will break when falling onto the sampler's opening. In addition, the fixed sampling tube has not enough volume to capture the sample fragments and will be filled rather fast building up lumps on top. The sampler should ideally only be 1/3 filled when cutting through the falling stream ensuring that the fragments sampled cannot escape the sample container after being collected. Hence, the suggested design has insufficient capacity to cope with the flow rate.

For moving the slurry lumps from the cutter to the collection container, the sampler should ideally be equipped with a transportation belt or screw inside the cutter suitable for sampling of non-free-flowing materials<sup>5</sup>. Since the slurry may vary in its flow characteristics due to varying water content, this transportation device must be designed to cope with all possible extreme cases concerning the slurry texture. Concerning the shape of the cutter edges, those should be designed in such a way to avoid build-up of the material. As for the chosen design with no cutter edge this means strike 2 according to TOS.

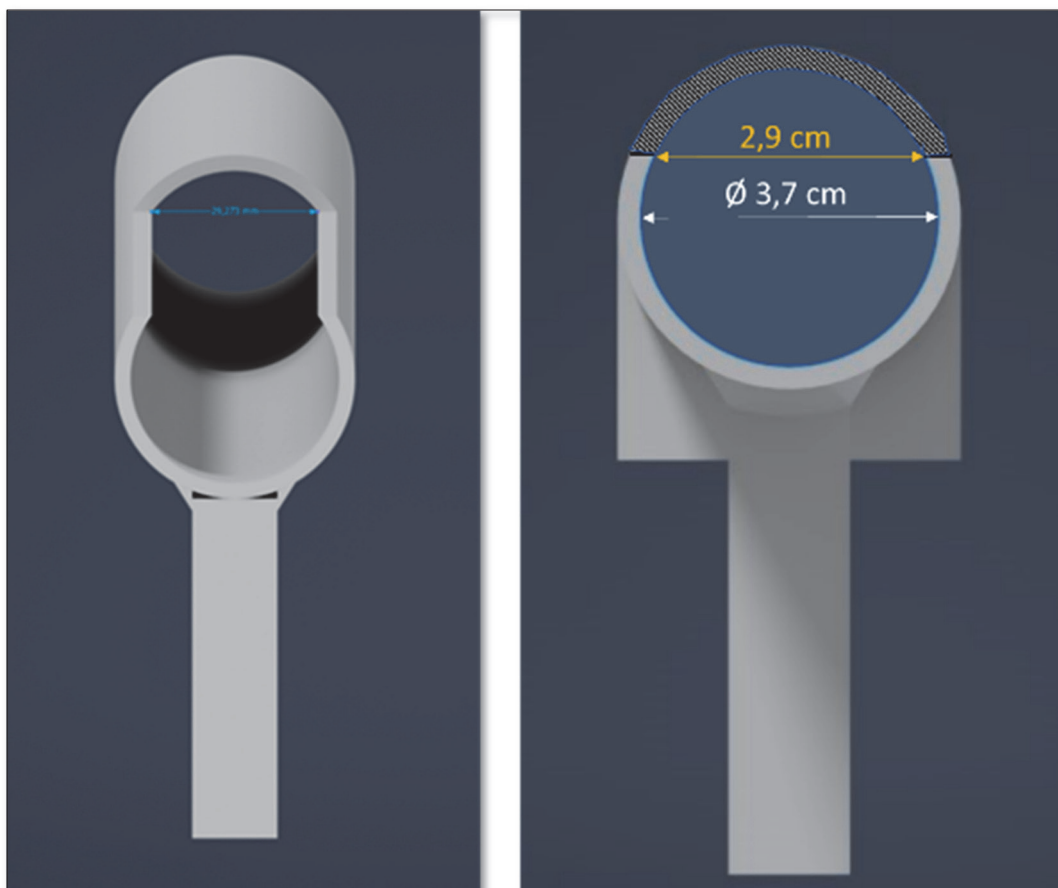

Figure 14. Illustrations of a section from the sampling collection tube to the left and cross section with measures to the right.

### Increment preparation error

As for the IPE, it is of the utmost importance to preserve the increment's integrity when extracted from the mass stream. Contamination of the sample by equipment due to abrasion or corrosion or by contamination through the surroundings should be kept at an absolute minimum. As for the planned sampler - though the prototype will be built in stainless steel - the final design will be built out of titanium which is a much-used material at Nikkelverk withstanding corrosive process environments. Thereby contamination of the equipment itself is avoided, however one must keep in mind that the environment around the filter presses might contain contaminants. After all, it is Nickel which is produced at the plant.

Though the designed sampler has already shown several faults according to TOS, the planned extraction of the sample from the sampling tube should be examined with regards to IPE. A piston in the sampling tube is supposed to push the sample out of the cylindrical formed tube and into a container. The sample extraction was theoretically thought to be viable, since the slurry contains approximately between 35 – 45wt% of water. Therefore, sliding the sample through the sampling tube seemed to be feasible. However, late field tests with a prototype showed that most of the slurry collected escaped the sampling tube and was lost before being pushed into the container. Losing large parts of the increment during extraction will increase the IPE considerably. As follows, this is strike 3 for the chosen design. As for the moment, unfortunately no further sampling reduction after the primary sampling has been planned. This leaves the primary sample exposed to the idea of grab sampling – possibly strike 4.

### Increment weighting error

Since emptying of the filter press frames can vary in time from frame to frame, the weight of the mass stream on the transport belt is not constant. For the planned sampler with a fixed position in the chute, this does represent a similar challenge as for a cross stream cutter. If the sampler would be built in a more traditional cross-stream cutter manner, care should be taken to avoid an unnecessary IWE originating from an uneven mass flow rate.

The correct sampling errors, like the fundamental sampling error (FSE), grouping & segregation error (GSE), process trend error (PTE) and process periodicity error (PPE)<sup>3</sup>, are not evaluated in the paper since the incorrect sampling error mentioned above should be minimized first.

## Conclusion - Engineering versus TOS

The automatic sampler currently designed and planned is witness to a shift from manual to automated grab sampling still containing major faults according to TOS and not giving a representative sample as an optimum. Emphasis has been on reducing the workload on the operators and on improving the sampling procedure, and not on TOS-conforming sampling. The process team, planning the automatic sampler, evaluated several design possibilities and rated them according to four criteria: ease of construction, EHS-considerations, reliability & low maintenance as well as sample quality in reference to the manual grab sampling. The planned design fulfils the requirements of the first three criteria. Unfortunately, the lack of TOS awareness in the selected team caused them to focus mainly on the engineering aspects. This is a typical example and a common problem in all industries basing decisions on data originating from samples – physical or by sensors. A main reason for this is the lack of awareness on TOS and unsuccessful communication and knowledge sharing from the sampling community acquainted with TOS.

A traditional mindset in industries is to achieve their goals with the least necessary effort. A known expression is “achieving 80% effect with 20% effort”. This type of philosophy promotes a quick response on occurring problems saving resources for other tasks. However, it will not make the sampling world a better place and contribute to a more sustainable future. Even though not all projects at a company can demand 100% effort from available resources, critical projects should aim for maximum impact with highest possible precision with regards to representative sampling. Engineers – like all others – should team-up with the other academic disciplines and keep in mind that equipment should not only work, but it should work correctly in all aspects, especially when it comes to representative sampling.

### Learning curve – is it the whole story?

Sampling of filter cake is obviously a demanding task. During the study there were several discoveries which showed the complexity of the problem. For example, in the process step of filling the filter press with iron sludge and starting the cleaning cycle with water, channels can form in the filter cake. This phenomenon leads to poor washing of the iron sludge in certain frames and leaves water soluble Nickel components in the filter cake, increasing the amount of Nickel unnecessarily lost. Therefore, a proper sample from the filter press might reveal such process problems faster and save valuable material. Furthermore, the texture of the iron sludge to be sampled can vary a lot, due to several process parameters and therefore, as discussed in the previous section, the material flow on the conveyor belt is not constant. These facts need to be taken into consideration when revising the automatic sampler.

Since the conductivity of the iron slurry sampled is an easy measurement done by the operator in the field and a sufficient indicator if soluble Nickel components remain in the filter cake, there should be a correlation between these two variables. However, as for today, this correlation is not existing due to many parameters distorting the relationship – one being the current sampling procedure.

In summary one must appreciate the will and effort to understand and improve the sampling procedure of the iron sludge. It takes time to grasp all aspects of a complicated problem and ensure that the chosen solution will work properly. The experience gained in a “trial & error” fashion will give a much more long-lasting knowledge for the involved parties than merely stating the theories in meetings and expect them to be applied in the field. To allow testing of ideas, even though they are not TOS compliant, can be of value on a personal and company level. Since the presented automatic sampler has not yet been built in full scale, reconsideration of the design will be necessary to incorporate the principles of TOS.

As new improvement projects steadily occur, and representative sampling might be one of the main goals to achieve, the team working on the problem should neither approach the challenge from a purely engineering perspective or a TOS angle alone. The team should be a multi-faceted group with different academic disciplines to cope with the complexity of the problem as well as to

find an approach with is easy to maintain and understand. Since the knowledge on TOS in companies is far from widespread, finding resources with TOS knowledge is like finding a needle in a haystack. And even though large efforts are made to circulate this knowhow in a broader community, there are still few recipients compared to the many companies existing. A challenge is still to promote the benefits of applying TOS in an easy and comprehensible manner and thereby increasing the impact field of TOS-supporters and the sustainable gains thereof.

## ORCID iDs

B. Elke Thisted: <https://orcid.org/0000-0001-5798-5144>

Eirik Djuve: <https://orcid.org/0000-0002-3559-4625>

## References

1. K.H. Esbensen and C. Wagner, "Theory of sampling (TOS): the missing link before analysis", *Spectroscopy Europe* **26**, 19–21 (2014). <https://www.spectroscopyeurope.com/sampling/theory-sampling-tos-missing-link-analysis>
2. K.H. Esbensen and C. Wagner, "Spear sampling—a bane at all scales", *Spectroscopy Europe* **28/5**, 26–29 (2016). [https://www.spectroscopyeurope.com/system/files/pdf/Sampling\\_Column\\_28-5.pdf](https://www.spectroscopyeurope.com/system/files/pdf/Sampling_Column_28-5.pdf)
3. K.H. Esbensen, *Introduction to the Theory and Practice of Sampling*. IM Publications Open (2020). <https://doi.org/10.1255/978-1-906715-29-8>
4. F. Pitard, *Theory of Sampling and Sampling Practice*, 3<sup>rd</sup> ed., Boca Raton, FL: CRC Press, <https://doi.org/10.1255/tosf.120>
5. G.J. Lyman, *Theory and Practice of Particulate Sampling: An Engineering Approach*. Materials Sampling & Consulting Pty Ltd., 43-44 (2019), ISBN 978-164633382-0, <https://doi.org/10.1255/tosf.121>
6. <https://mwwatermark.com/articles/what-is-a-filter-press/>

## Choosing Metallurgical Samplers or Static Cutters for Process Control in Slurry: when or why to avoid the Increment Delimitation Error

Reinaldo Novaes<sup>a</sup> and Michael Hidding<sup>b</sup>

<sup>a</sup>Rua José Dolles, 264 · Votorantim · SP 18116-710 · Brazil, E-mail: Reinaldo.Novaes@FLSmidth.com

<sup>b</sup>Osborne Park, Perth WA 6916, Australia, E-mail: Michael.Hidding@FLSmidth.com

Despite “sample collecting”, with the objective of evaluating the quality of a material lot, being a very ancient activity, and many books and papers being published with the purpose of “educating” the sampling community, we can say that the Theory of Sampling - TOS (developed by Pierre Gy) is the one that gave the best approach of the potential, and most common, errors of this activity.

The focus of TOS in the early days was primarily dry particulate material, maybe because it presents bigger challenges in terms of heterogeneity, but there are other areas that have discovered the use of this precious tool to solve the same issues on many other kinds of materials, but it is still not universally adopted. For instance, there is a belief that liquids are completely homogenous, as if every liquid have the same behaviour as water, but it is not true, especially when we talk about mixed materials, not soluble between them, and with different densities. For instance, ore slurries (pulp), is a suspension formed by pulverized ore, flotation reagents and process water

This slurry may seem a homogenous substance, looking from the top of a flotation cell or discharging in a thickener, but, any fluid, flowing in a pipe develops a specific profile of speed which is dependent of the rheology and of the pipe wall friction, etc. Other important variables to consider in the make-up of mineral suspension include the concentration gradients through the flow profile and specific gravity of the particles.

This work evaluates the types of slurry samplers or static cutters to answer the question: “Which equipment do I really need?” The answer to this question will help the project owner make the correct decision for plant sampling – including longer term viability.

### About Slurries

In basic terms slurry is a mix of ore and water but, in the real world, slurry is actually a mix of pulverized ore of unknown constitution, with a characteristic size distribution curve, plus flotation reagents and a very diluted solution of an unimaginable combination of solutes, called process water. If we take notice of these parameters, it is impossible to imagine something homogeneous made in this way.

Of course, it all seems homogenous when you look from some distance, or when the material is flowing in channels but, as the slurry is not a clear liquid, it is impossible to see inside the material and to see the particles behaviour without some special tools. Thus, it is very difficult to guarantee whether the material is homogeneous or not - it is a dangerous assumption to believe it is.

However, when compared with dry ore, which has generally bigger particles and possibly a wider range of distribution, slurry seems i “homogeneous”, or accurately speaking, less heterogeneous. However, the segregation issues are still in place with a different name - sedimentation in comparison to dry ore where any movement causes segregation, with slurry the movement is necessary to avoid it. Slurries need to be under agitation.



Figure 1. Slurry and dry ore.

### Slurry sampling

An engineer or plant designer, unfamiliar with the complexities of slurry sampling, visualises a perfect flow of a homogeneous material and therefore believe it is appropriate just to use any kind of deviation flow to “take a sample”, even if they know the basics of sampling theory.

Once you understand the general idea about the characteristic, behaviours and especially the heterogeneity of slurries, it will only then be possible to think about how to sample this material correctly. To define the best sampling solution, it is crucial to know about the material process (e.g. is it a gold processing or a copper concentrate plant?) and to know about the purpose of your samples (quality control, process control, metallurgical accounting). Besides this, there are some other characteristics that must also be checked.

- Movement – the slurry needs to be in constant movement to create an almost one-dimension spatial distribution to be cut.
- Pressure – to evaluate the possibility to cut the flow without breaking the pressure, creating a spray where it is impossible to take a proper cut.
- Speed – to evaluate the possibility of cutting the flow without losing material from the cutter spoon.
- Additives – to evaluate the behaviour of the material and decide the best drainage angles, apertures, agitation need, etc.
- Particle Size Distribution – big range means big segregation issues.
- Solid content – to evaluate the behaviour of the material and decide the best drainage angles, apertures, agitation need, etc.
- Temperature – Generally disregarded, but temperature changes the viscosity and consequently the flowability, so again drainage angles, apertures and agitation need attention especially for the regions with a big difference between day and night temperatures.

With knowledge of these parameters, it is possible to start selecting the best fit for purpose sampling equipment.

### Lack of knowledge

Mining companies are being pushed by communities, investors, employees and sometimes even owners, to provide clear and confident information about results. And, to fulfil demands they are looking for engineering companies which usually have more knowledge about sampler installation, not about sampling. Unfortunately, the knowledge of correct sampling is still restricted a small group in the industry.

With technological development of the capital equipment and processes used in the mineral industry, the sizes of the flows are growing considerably, increasing the need for appropriate space to install a proper sampler. This means generally extra height, in turn leading to bigger structures and bigger investments; so, engineering teams, without proper knowledge, looking to reduce constructions costs, and based on the false idea about the slurry homogeneity, are presenting “magical” solutions with deflectors, deviations flows, pressure pipe and other static cutters

“The sampling operation of a flowing stream is usually performed by one of the three following schemes:

- Taking the whole stream part of the time. Figure 2
- Taking part of the stream all the time. Figure 3
- Taking part of the stream part of the time. Figure 4

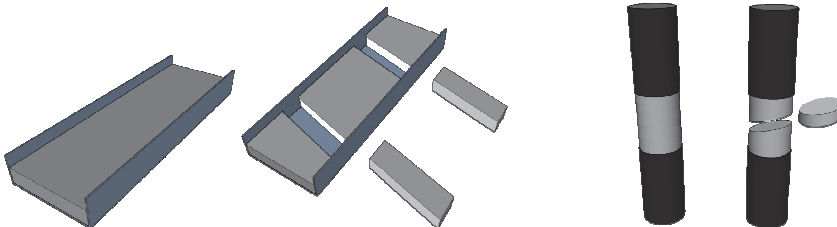

Figure 2. Whole stream taken

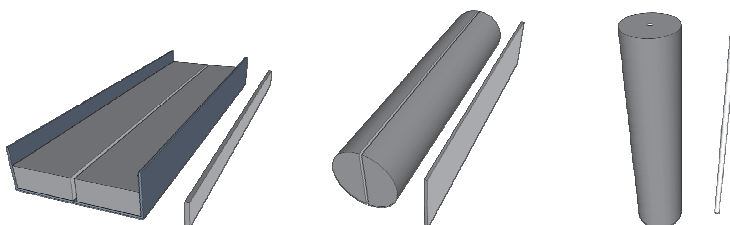

Figure 3. Partial stream all the time

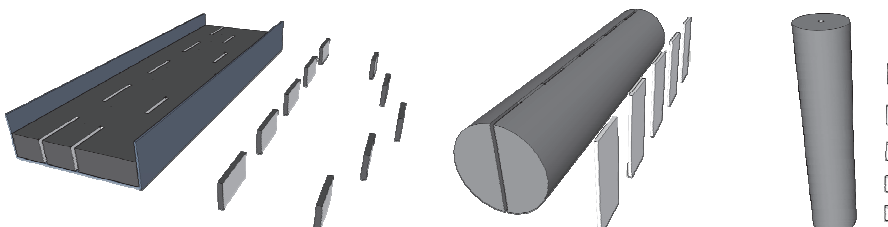
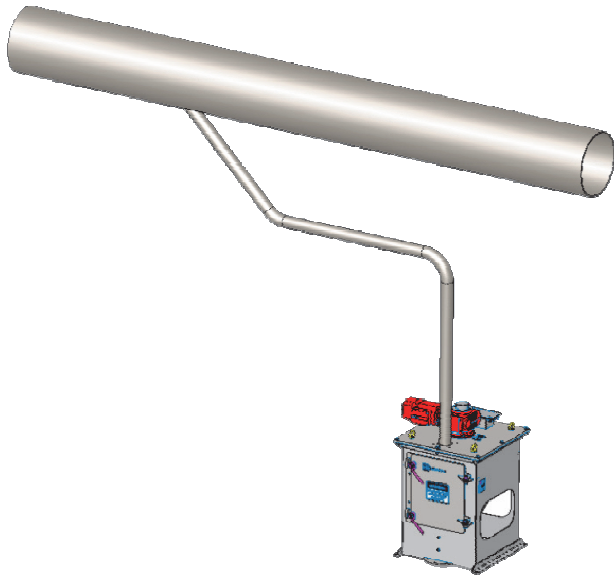

Figure 4. Partial stream partial time

As mentioned by many authors, it is impossible to take a sample, or correct sample, using static cutters (figures 2 or 3), it will be always biased due the Incorrect Delimitation Error. No metallurgical account can be carried out based on the results from that collected material.

However, the material collected by these device types, once sent to Online Analysers, can produce a very good and fast answer about the variations of the process permitting a more effective process control. It can be very useful for processing plants that receives material from different mining areas or even the different suppliers. With a good analyser is possible to get many results per hour, offering a good curve of the process variation and permitting many adjustments.

Based on the above, the same engineering team are completely confident that this “magical” solution can provide a representative sample. The same thoughts are being used to defend the use of pipe deviator; a small pipe came from a big one to reduce the flow size to take a small “sample size”.



**Figure 5. Pipe deviator**

On the other hand, the serious engineering teams are trying to build good systems, including correct samplers, or better, correct sampling systems. But too often the purchaser or engineering responsible, know very little about representative sampling so generally they prefer the “simple solution”.

## Metallurgical Samplers X Static Cutters

A sample or increment is a relatively small quantity of material, so taken from a lot as to be representative in respect of the quality characteristics to be assessed. If it is not representative, it is not a sample, just a mis-illustration of the lot.

Following this line of thinking, only metallurgical samplers can be called Samplers, so, to facilitate the understanding we use the expression Sampler for metallurgical devices and Static Cutter for the other devices.

A Sampler is a device to take increments from a one-dimensional stream of material, in the following conditions:

- The linear or circular velocity of the cutter spoon be constant during all the time necessary to cross the entire stream.
- The velocity remains uniform during the collection of all increments
- Geometry of the cutter spoons: for a straight trajectory, the edges should be parallel and for a circular trajectory, edges should be radial.
- The increment is the portion of the one-dimensional stream taken each time the cutter spoon crosses the stream
- The cutter spoon volume and aperture should be generous enough to ensure that the cutter behaves as correct as possible (paying attention to high solids content, froth factor, etc)

A Static Cutter is a device where apertures, circular or rectangular, are installed in the stream path, to deviate a part of this stream, in the following conditions:

- For pressurized flows, the aperture should be circular, and the flows shall be on the ascending vertical pipe.
- For gravitational flows, the aperture should be proportional to the pipe shape, circular for pipe and rectangular for box, launders, and square pipes.
- The aperture should be enough to permit the material enter freely (attention high solids content, froth factor, etc).
- More apertures give more opportunities for the flow but may still be just as biased as single apertures.

In other words, to be absolutely clear to take a metallurgical sample, representative enough of the entire lot, it is mandatory to take a complete section of the free-falling stream. Any deviation of this rule will generate a Delimitation Error which will affect the results of the evaluation.

A Static Cutter is not a Sampler, but it can be an important tool to control the processes and can be used under certain conditions.



## Engineering phase - How to choose the best solution?

Any project, during the engineering phase, should consider all requirements of the processes and quality controls, including the sampling points. Some parameters, such as the following, should be defined:

- In order to close the loop for metallurgical accounting, what/where are the main points for control of the overall process?
- For process plants, what is the frequency of the metallurgical accounting period
- What are the critical process control parameters?
- Where will the collection/sampling points be located?
- What level of automation to control the process, once the sample is collected, will be used?

With this information it is possible to evaluate the reason for sampling, which determines height and clearance required to install appropriate Samplers. It can also help to define a layout that permits the optimum collection of material (and pipe routing) for a centralized on-line analyser.

Some examples

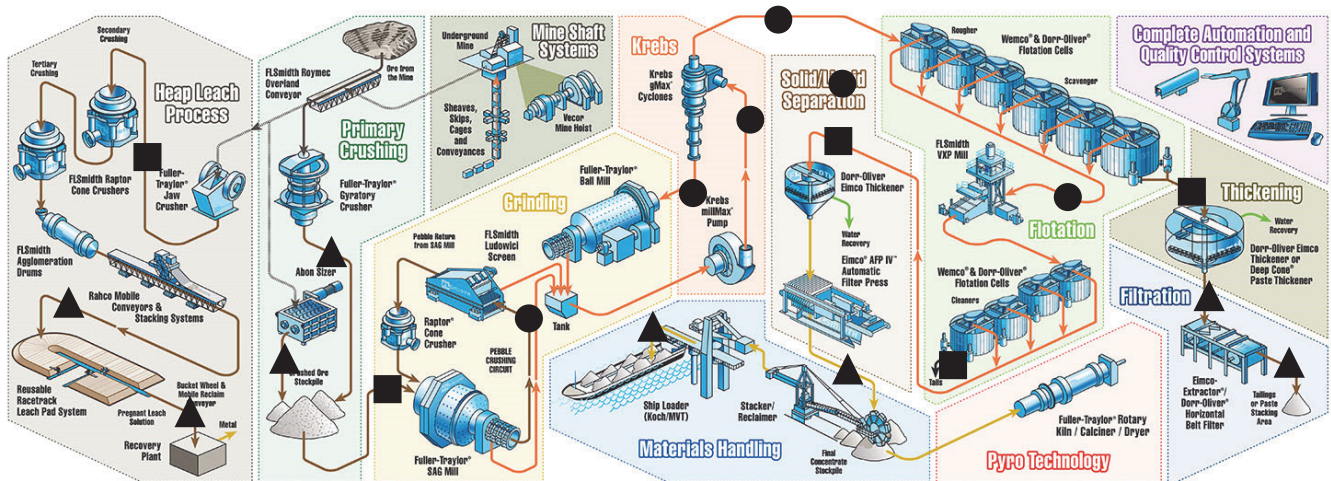

Figure 6. Samplers and Static Cutters location.

In the figure the circles represent Static Cutters, and the squares represent Samplers in the most common application points and the triangles show alternatives points of installation for Samplers.

The Static Cutters can be replaced by Samplers when the process evaluation is a critical stage of the process. The opposite, replacement of Samplers by Static Cutters, cannot be done,

For metallurgical accounting it is crucial to know the inputs and outputs of the process, for:

- Plant feed
- Final product (concentrates)
- Tailings

In this application the devices should be Samplers, even if the samples also need to be sent for quick analysis, for process control. A different frequency of cuts can be applied to attend both needs; feed the analyser and create a global sample to send to the lab.

Special care is needed with the direction and distance between the sampler and the analyser, if the increment discharge is intermittent.

For process control the idea is the same as accounting, but with some circular flows, (e.g. for mills and cyclones) it is more difficult, so it is also important to know the "bottlenecks" of the process to decide where to install the Static Cutters, that will feed the analysers.

The same care about direction and distance can be taken in the Static Cutters, but in this application a constant gravity or pumped flow (without buffer or other type of holding tanks) can be provided to avoid sedimentation on the analyser feed pipeline

## Final comments

It is easy to be confused with the sampler types, especially with some devices that promise metallurgical results but are also biased. Maybe they can be considered less biased than some options or even manual "sampling" and, due to a lack of knowledge, the engineering companies choose them because they are looking for less expensive solutions. Solutions that require less head height, less space and minimal interferences on the drawings they have already done but pay no attention to the integrity of the results.

It is very common to see requests for one single stage sampler, without information about the sample purpose and then to ask the manufacturer to specify the number of increments, increment size and final sample mass. This demonstrates the unfamiliarity about TOS and highlights the work still to be done by the sampling community. If the final customer is involved in the process, the risk of not fairly comparing systems (between single stage and a compliant system) is less, however it can still happen, and here too more education is required.

## Conclusion

Samplers and Static Cutters are reliable devices for different applications and can be used for most processes. Each commodity, each project, each plant is unique and needs to be evaluated under the proper characteristics in terms of process, and consequently, in terms of sampling needs.

To choose the proper device for each application is a simple task, but it requires knowledge - so is important to look for the specialists help. If implemented correctly the right sampler can save a lot of money during the plant operation.

## Proposal

Based on the dialog above, I am proposing to avoid the use of the expression SAMPLER for any kind of device that does not meet the definition of a true cross-stream sampler. This subtle change in description could save a lot of confusion when purchasing decisions about sampling equipment are taken.

## References

1. Pitard, F.F., 1993, Pierre Gy's Sampling Theory and Sampling Practice, 2nd Edition, CRC Press LLC, Boca Raton, FL.
2. A.C. Chierigati and F.F. Pitard, "Fundamentos teóricos da amostragem", in Teoria e prática do tratamento de minérios: manuseio de sólidos granulados. Chaves, A.P. (Org.), Signus Ed., Sao Paulo (2011), pp. 299–338.



## Cross Belt Sampler: Mechanical Design of the World's Largest Hammer Sampler for Bauxite Export Contractual Requirements

---

W.P. Slabbert

Email: [willems@multotec.com](mailto:willems@multotec.com)

---

**Automated, mechanical cross belt (hammer) samplers remain popular because they are easy to retrofit into brown fields applications or green fields projects when cross stream samplers are not always designed into the plant layout from initiation. Cross belt samplers require less headroom and are easy to retrofit onto existing conveyors. Despite disputes about possible delimitation and extraction errors resulting from hammer samplers, they are not excluded for use from ISO sampling standards (13909 - Coal and Coke and 8685 - Bauxite) but are excluded from others (3082 - Iron ore). Possible errors can be mitigated by applying “know-how” into the bespoke design of a hammer sampler for installation on a specific conveyor belt system. This paper discusses the design details of a primary stage hammer sampler for a Bauxite ship-loading sampling plant. The design requirements of 10 000 metric ton per hour ship loading rate, 100mm particle top size, 1800mm wide conveyor travelling at 5.4m/s, results in a hammer sampler that takes up to a 260kg increment with each cut. The application requires more torque and at faster responses than that delivered by 10 Bugatti Chiron’s combined and is (to my knowledge) the largest of its kind requiring a unique high-torque-at-low-rotational-speed drive system where conventional geared motors could not achieve the necessary output performance. Even though the sampler is the primary stage to a complete operational sampling plant, the emphasis is on the power requirement calculations, the mechanical design, components, materials and features of this unit that makes it not only mechanically operational but also intended at high sampling precision levels prescribed by the Theory of Sampling (TOS). Despite a small statistical bias detected for the sampling system (not the hammer sampler only), the sampling plant performed within the maximum tolerable bias specified for the commercial trade application and is fit for purpose.**

**Keywords:** cross belt sampler, hammer sampler, TOS, mechanical design.

Credits: The Multotec Samplers design team who contributed to the design in their respective disciplines.

### Introduction

The comprehensive application of the Theory of Sampling (TOS) into minerals sampling applications is still limited globally despite ongoing, active, and dedicated contributions and learnings from free publications by (amongst others) the International Pierre Gy Sampling Association (IPGSA). Some believe that the various related textbooks, technical publications, papers, best practices, and learning are too far removed from practical implementation to be understood by the industry (Steinhaus and Minnitt, 2014<sup>1</sup>), possibly because the theory is perceived as ambiguous (Pitard, 2005<sup>2</sup>). Pitard (2005<sup>2</sup>) goes on to explain that sampling standards are lacking in detailed prescriptions towards correct mechanical equipment designs that can reduce or eliminate selective materialization errors that known for large magnitude sampling error contribution. Without detailed prescriptive standards, the responsibility is transferred to knowledgeable stakeholders, engineering companies, consultants, and Sampling Equipment Manufacturers (SEMs) to ensure sampling projects achieve their intent. Sellers and buyers of mineral commodities are equally at risk of bias and/or poor precision level sampling where inaccurately reported grades occur. Sampling results (lack of) confidence levels can lead to remuneration losses/gains, let alone reputational damage towards quality assurance and control of large mining companies. The responsibility of the experienced SEM and their inputs into reputable sampling projects is explained by Steinhaus and Minnitt (2014<sup>1</sup>). SEMs have invaluable experience with sampling of mineral ores (Steinhaus and Minnitt, 2014<sup>1</sup>) and can often find themselves not only as preferred suppliers to the project, but at the same time consultants/advisors who contribute towards and promote correct sampling and uphold their responsibility where they form part of the client’s decision making panel.

This paper explains the SEM's key involvement and hence the panel's consideration of influential project parameters that concluded the design of potentially the world's largest hammer sampler over a theoretically "more correct" belt end crosscut sampler.

### Hammer cross belt sampler history

Hammer samplers first appeared in the 1960's originating from German mineral bulk solids processing equipment supplier, Siebtechnik GmbH. The technology is still commonly used as primary belt samplers to sample periodic material increments from a production conveyor belt by scooping perpendicularly to the direction of conveyor travel across the belt width. Hammer samplers remain popular because they are easy to retrofit into brown fields applications or green fields projects where cross stream samplers require more headroom and are also not always designed in or space allowed for in the plant layout at project initiation. Hammer samplers take smaller increments than cross stream equivalents, especially for high-speed conveyors and this will often result in smaller downstream sampling plant with consequent reduced footprint and substantial cost savings. Despite purist TOS work (Pitard, 2005<sup>2</sup>; Robinson, Sinnott, and Cleary, 2008<sup>3</sup>) about possible delimitation and extraction errors that could result from automated mechanical hammer samplers – they are not excluded for use from ISO sampling standards (13909 - Coal and Coke and 8685 - Bauxite) but are excluded from others (3082 – Iron ore). It is my view that the possible errors can be mitigated by applying "know-how" into the bespoke design of a hammer sampler for installation on a specific conveyor application.

### Project Background

The client understood the importance of correct sampling as an important contributor to quality assurance of bauxite grade between port-and-buyer. Commercial payment terms were structured around ISO 8685: 1992<sup>4</sup> with specification of Aluminium and Silica grade maximum tolerable bias (MTB) levels. Compliance to ISO 8685 and sampling plant performance to sampling variance within the MTB levels are therefore important to defend commercial trade risks. The client identified the need for correct sampling and ensured that commercial trade conditions were written around the applicable commodity ISO sampling requirement. They did their part well, only to be let down by the executing engineering company and a Sampling Equipment Manufacturer (SEM) who proposed a single stage hammer sampler. Apart from mechanical design inadequacy and evident under designed parts, this single stage sampling system would result in enormous composite sample masses forcing the operation to take too little sample cuts required for an ISO compliant sampling scheme. Thankfully, informed client technical adjudication role-players compared the single stage, primary sampler proposal against their experience with multi-stage sampling plants on iron ore, coal and manganese and probed the compliance of the offer with a different SEM. This SEM consulted and guided project stakeholders on: 1) sampling correctness, 2) adequate automated mechanical sampler design and 3) understanding the requirements for ISO compliance,

A further project constraint included production conveyors which were under construction. SEM advice on sampling correctness of a cross stream primary sampler was explored but concluded that existing conveyor designs and transfer tower heights did not allow for belt end crosscut samplers to be fitted at the head pulley. A feasibility study was conducted, with conceptual equipment designs from the SEM, to determine the techno-commercial project implications to install cross stream samplers. The anticipated project costs and reworks on existing infrastructure rendered this option to be unfeasible despite recommendations that quality sampling should be independent of economic aspects (DS 3077:2013<sup>5</sup>). Suitable positions were identified for installation of a primary hammer (cross belt) sampler, despite structural engineering challenges on existing conveyor stringer load allowances that would have to be overcome. Despite other ISO sampling standards prohibiting the use of cross belt samplers, ISO 8685<sup>4</sup> does not exclude hammer samplers from use in Bauxite sampling applications. The run of mine (ROM) material is crushed down to -100 mm export size using Mineral Sizers which are promoted to generate less fines and more regular shaped product both of which are suitable characteristics for representative cross belt sampler applications.

The client's mandate to be recognized as a reliable bauxite supplier overcame the technical and commercial hurdles to install a multi-stage sampling system with cross belt primary sampler as a "compromise" to cross stream samplers which are better regarded by sampling purists.

## Literature Review

### Cross stream versus cross belt sampling

The advantages, disadvantages, precision levels, reliability, and comparisons between cross stream (crosscut) and cross belt (hammer) samplers are discussed in detail by Steinhaus and Minnitt (2014<sup>1</sup>). They conclude (referencing the work of Rose, 2012<sup>6</sup>) that superior practical precision levels are achievable by cross stream samplers but not easily attained in poorly installed, inadequately maintained and neglected sampling plants where cross belt samplers are easier to install. The simplified installation is not only appealing commercially on project outcomes of cost and time, but the simplicity often results in better integration of the sampler with the production plant infrastructure and ultimately more likely to pass “bias tests” - still used as validation criteria of sampling plants for commercial mineral commodity trading contracts. Where hammer samplers are allowed by mineral ISO standards, they remain viable alternatives for practical implementation, but the responsibility lies with all stakeholders and particularly the SEM expertise and inputs to ensure successful sampling projects.

### Mass versus time-based sampling and the weighting error

The Weighting Error is defined by TOS as the error that results when a sample increment weight is inconsistent despite consistent lot sizes (production weight intervals) it is supposed to represent - where the sampling rule of proportionality is not conserved. In the case of hammer samplers, they can only sample the material loaded on the belt at the instance of increment extraction. Even if the cutter speed set point is changed in between consecutive increments, the sampling action will not result in a different sample increment weight because the hammer sampler will still sample the material burden on the belt (now only at different velocity through the stream). The increment mass extracted by a hammer sampler will only change if the velocity of the production conveyor it is sampling from changes and results in a lower loading (ton per meter) on the belt. If each hammer sample increment is intended to represent a constant production weight, where the sample cut is prompted by a cumulative weightometer input in a mass-based scheme, there could be a discrepancy in the ratio of sample increment weight over constant production weight, between consecutive increments. For this reason, hammer samplers can only be used on a time basis.

Cross stream samplers, however, can be controlled over a defined range by varying frequency drives to change their cutter speed before a cut is initiated and then cut through the stream at that instantaneous speed set point. This possibility allows a cross stream sampler, running on a mass-based sampling scheme, to adapt its cutter speed to spend more or less time through the stream and result in a constant ratio of sample increment weight over constant production weight. Cross stream samplers can be used in mass- or time-based sampling regimes. For use in time-based regimes, the cutter speed must be consistent between cuts at a fixed set point irrespective of instantaneous throughput.

## Cross stream hammer sampler design

### System parameters: design inputs for this application

Table 1 below lists the client conveyor and material properties design inputs to the SEM for equipment mechanical design for this bauxite sampling application. The system design parameters resulted in a hammer cross belt sampler larger than previously built by SEM Multotec Process Equipment and affiliated Licensor Siebtechnik GmbH and to our knowledge, is the largest of its kind in the world.

**Table 1. Conveyor and material design input parameters.**

Conveyor parameters		Material parameters & properties	
Input	Value	Input	Value
Production throughput	10 000 ton/h – max. 7 000 ton/h – nom.	Particle nominal top size	100 mm**
Conveyor width	1 800 mm	Bulk density for volume	1.4 ton/m <sup>3</sup>
Fixed belt speed	5.4 m/s	Bulk density for weight	2.3 ton/m <sup>3</sup>
Idler angle	45° onset parameter	Nature	Abrasive, sticky
Idler angle *	Sampler design dictated 35° *	Transportable Moisture Limit	14%

\*The sampler design dictated a 35° idler angle requirement. Constraints on belt curvature profile, cutter to belt gap tolerance and sample increment discharge trajectory are discussed in more detail in applicable sections to follow. The production belt profile was transitioned from 45° to 35° (and back) in 2.5° intervals with SEM supplied idler sets.

\*\* Low fines fraction and regular, cubic-shaped particles expected from ROM crusher technology: mineral sizer.

Main components of the hammer sampler

The main components of the hammer sampler are shown in Figures 1 and 2 below. The design of these components' critical variables, parameters and tolerances are discussed in the following subsections.

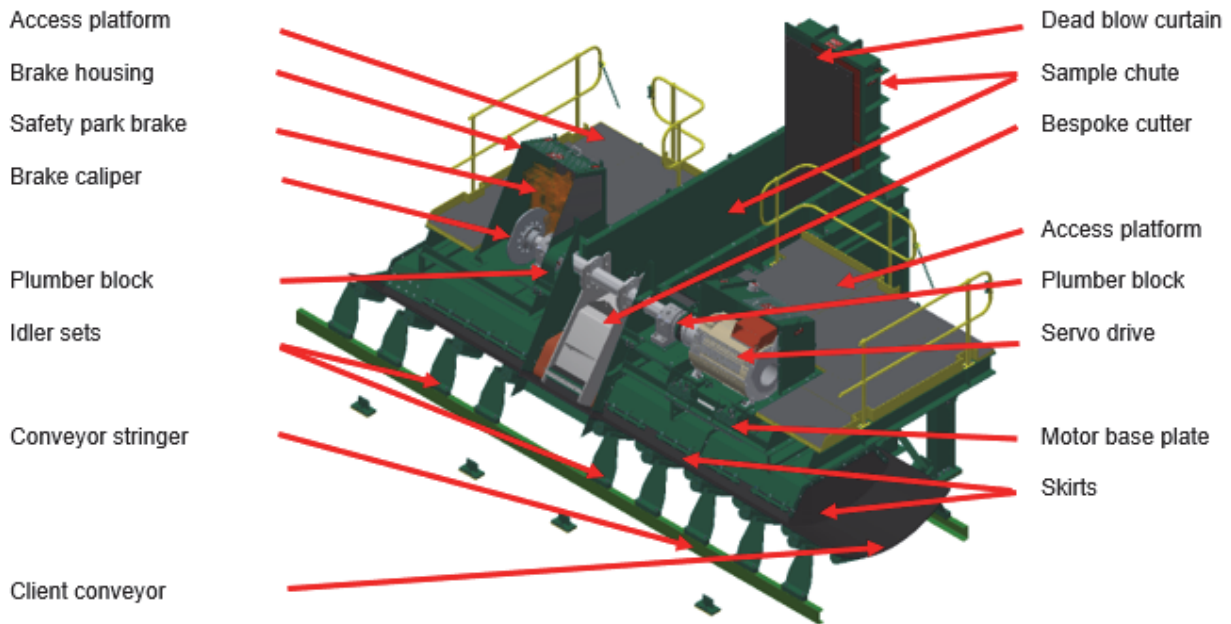

Figure 1. Main components of the hammer sampler seen from the drive end – sectional view without support frame. Handrails appear incomplete resulting from the sections made on the model to show the operational parts.

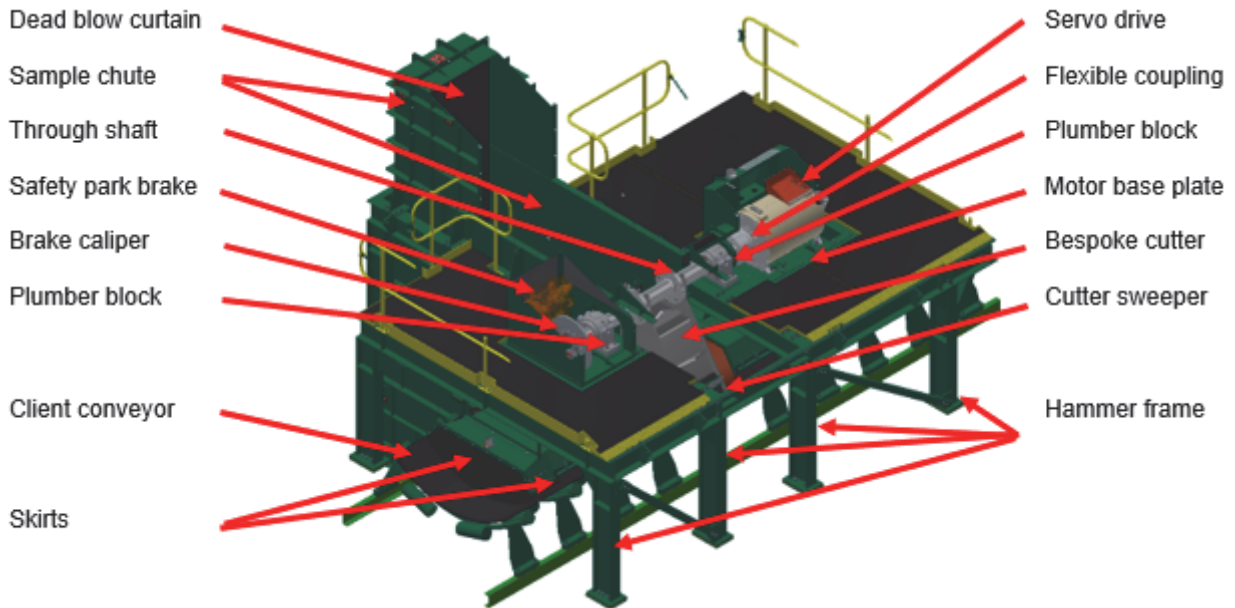

Figure 2. Main components of a hammer sampler seen from the park brake end –sectional view now including hammer integral support frame.

Cutter

The cutter is the heart of the machine and must be designed to minimize error generating mechanisms as set out by Pitard (2005<sup>2</sup>) and Robinson, Sinnott and Cleary (2008<sup>3</sup>). The resultant design outcomes of cutter mass, it's center of gravity and weight of increment that will be extracted by the cutter geometry feeds into the design power requirements of the hammer sampler. All the SEM cutters are bespoke design to the installations to result in accurate sampling with minimized materialization errors. The sections below elaborate on the additional detailed design considerations for this demanding application.

### Straight versus skew cutter

Through their modelling simulations on coal Robinson, Sinnott and Cleary (2008<sup>3</sup>) quantified the extent to which both skew and straight cut hammer samplers were prone to delimitation and extraction errors when “over-sampling” material in their respective mechanisms. Their findings are summarized below:

- Straight cut hammer samplers: the leading cutter blade side wall (upstream) is subject to material pushing up against the outside of this cutter wall, which under friction from the approaching conveyor, is also thrown into the sample chute erroneously when not designated to be delimited between the cutter blades.
- Skew cut hammer samplers: the combination of 1) angle of the cutter blades and 2) speed of cutter relative to conveyor speed could result in material not delimited to be part of the sample, to be bulldozed off the belt by the trailing (downstream) cutter edge.

Both designs are not without possible bias if not carefully designed for the application. However, straight design cutters can be supplemented with sturdy rubber curtains mounted to the sample discharge chute on the outside of either cutter blade side wall. These curtains can deflect unintended material, built up on the side wall of the leading blade, back onto the production conveyor belt and prevent the oversampled material from reaching the sample chute and minimize or even eliminate particle misplacement. The straight cutter design is selected for this application and suitable rubber curtains designed with maintenance access to frequently inspect their condition.

### Cutter opening (width/aperture)

Robinson, Sinnott and Cleary (2008<sup>3</sup>) explains a mechanism of a bow wave in front of the cutter movement through the stream that “blocks” the cutter opening and result in a delineation error where oversampled material is incorrectly thrown into the sample chute. The mechanism is applicable to straight- and skew cut hammer samplers. These extraction and delimitation errors result from not only direct interaction between sample-designated particles and the cutter blades, but also propagated interactions between designated particles and the indirect momentum transfer they effect to neighboring particles through a bridging effect. The proportional mass of oversampled material decreases with increasing cutter width where the effect of bridging is less pronounced. The authors recommend that cutter width (opening/aperture) be at least four times the particle top size being sampled - the maximum tested in their simulations. Naturally, the cutter blade leading edges must be sharpened in their design (and maintained) and the blade wall thickness as thin as possible to allow a “clean” cut while also maintaining structural integrity in its application.

A cutter width of 500mm with sharpened leading cutter edges, safe maintenance access hatches to regularly inspect edge condition and abrasion resistant stainless steel material of construction with suitably thin wall thickness of 20mm (a finite element analysis confirmed design) is designed for this application. The cutter walls (Figure I & II above) are designed to be fabricated from the same sheet of continuous steel to eliminate possible inward steps that can contribute to bridging and soft edges close to the belt surface, both of which can result in delimitation and extraction errors (design allowances on recommendation of Pitard, 2005<sup>2</sup>).

The 500mm cutter results in a linear proportional 1.67 times larger sample increment, calculated using equation [1]. This larger increment may result in larger and more downstream sampling plant infrastructure (crushers, sub-sampling equipment and interlinking solids handling conveyors and chutes) but through a case study had no significant cost addition to processing a three times nominal top size, 300mm cutter increment.

$$M_{\text{increment}} = \frac{W_{\text{cutter}} \times \dot{M}}{v_{\text{conveyor}} \times 3600} \quad [1]$$

$M_{\text{increment}}$  is the increment mass in kg

$W_{\text{cutter}}$  is the cutter width in mm

$\dot{M}$  is the production throughput in ton/h

$v_{\text{conveyor}}$  is the conveyor belt speed in m/s

### Conveyor belt profile and gap between cutter and belt

Robinson, Sinnott and Cleary (2008<sup>3</sup>) reports a delimitation error through selective material loss of the -12mm fraction through the gap between back of the sampler cutter and the production conveyor belt. Their results were recorded for system parameters of cutter-to-belt gap of 25mm for a PSD of -50mm top size coal also containing <12mm particles. A standard industry practice and necessity (Pitard, 2005<sup>2</sup>) is to install a rubber sweeper at the back of the cutter (Figure 3) to sweep the sample-intended fines from the belt and prevent the potential delimitation error. Pitard goes on to explain that even though



a rubber sweeper might be installed, a large cutter-to-belt gap will still result in losses when fines build up against the sweeper and are deflected sideways underneath the side walls of the cutter.

For this application the cutter gap is designed to 5mm. The client conveyor idler angle of 45 degrees did not allow a smooth radius of curvature but rather segmented trapezoidal steps between the 5 idlers which created 4 dead zones that cannot be sampled clean off the belt by a cutter with fixed radius of rotation. The cutter gap could only be reasonably maintained over the 1800mm conveyor width using custom design idler set designs using 5 roll, offset idlers, at 35° idler angle (Figure 4). The client conveyor had to be transitioned over SEM supplied idler sets from 45° to 35° and back to 45° in 2.5° intervals along the length of the conveyor. Conveyor idler transition should not be done without carefully considering belt tension, deflection points, stress points and belt loading to determine the length of transition and spacing between idler sets.

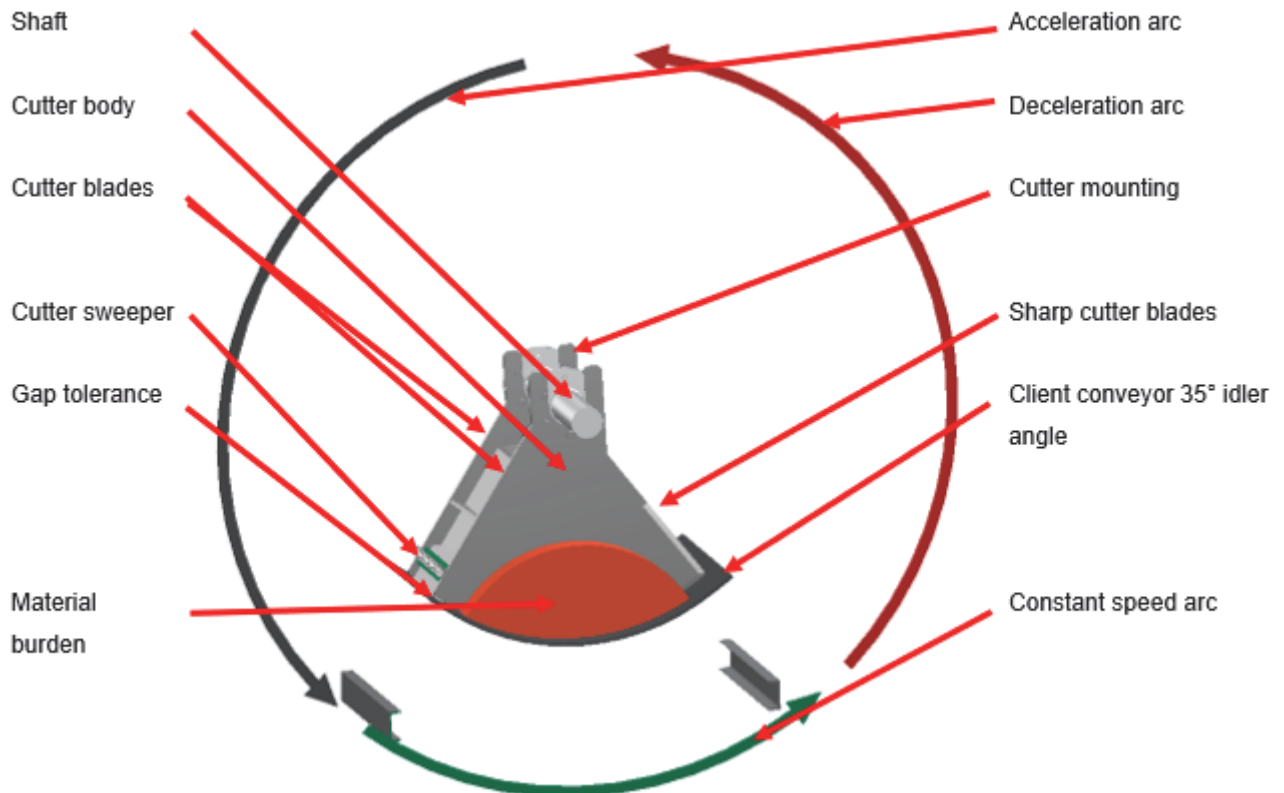

**Figure 3. Cutter capacity relative to material burden and rotational arcs available for acceleration (black), constant speed (green) and deceleration (red).**

Pitard (2005<sup>2</sup>) explains: "The last thing that should happen is for the cutter to lift or damage the belt as it enters the stream. Therefore, a gap between the bottom of the belt and the lower part of the cutter is necessary, especially as the cutter enters the stream". He recommends a pronounced gap between cutter and belt at the leading edge of the cutter but at the same time comments that this clearance can result in sampling errors. To prevent possible damage to the client conveyor, the 5mm cutter gap specified for this design across the full cutter arc therefore must be maintained with a tolerance of  $\pm 0.5\text{mm}$ . (This design consideration was paramount in sampler installation onto the conveyor because it meant that the 15 ton hammer sampler, capable of 16 kN.m of torque in 0.852 seconds, installed on an inclined belt, 14m above ground level, on its own support structure straddling the production conveyor has to be aligned overall to a tolerance of  $\pm 0.5\text{mm}$ . This was quite an engineering constraint, but a feat that was achieved, even though more costly than conventional hammer sampler installations.)

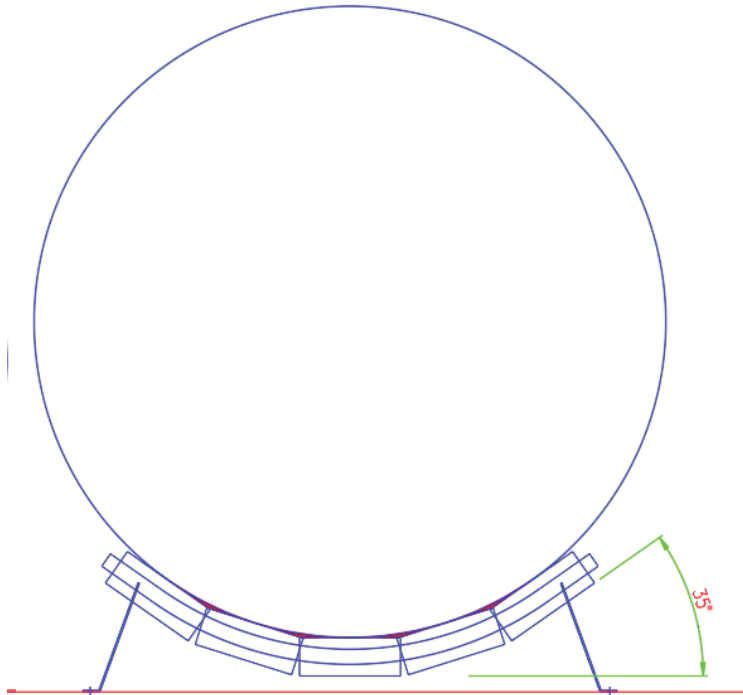

**Figure 4. Cutter rotational diameter showing design tolerance between cutter and belt given the SEM supplied 5-roll, offset, 35-degree idlers to the 1800mm conveyor. The proportionately small dead zones remaining in purple can confidently be cleaned off with a sweeper minimizing delimitation errors.**

#### Cutter geometry and capacity

As recommended by Pitard (2005<sup>2</sup>) the cutter geometry is designed to generously cover the calculated material profile on the belt (Figure 3). The depicted burden profile is calculated using the conservative bulk density parameter for volume design. Furthermore, the total cutter capacity is designed at 1.5 times the increment (extracted burden profile) volume calculation to prevent sample increment reflux that would result in delimitation error.

#### Cutter speed

Cutter speed is designed according to recommendation by Robinson, Sinnott and Cleary (2008<sup>3</sup>) who concluded that for a straight cut hammer sampler, a cutter speed of 1.5 times belt speed minimizes delimitation and extraction errors evident from the minimized amount of “oversampled” material thrown from the production conveyor. Given the production conveyor velocity of 5.4m/s, the cutter tip speed is designed at 8.1 m/s. The SEM confirmed with the client that after a soft start, the production conveyor is a fixed speed design. A process interlock to prevent sampler action until design belt speed is reached is employed.

Considering error generating mechanisms by Pitard (2005<sup>2</sup>) from insufficient sample discharge chute geometry: the design cutter speed will discharge the increment over the original client conveyor idler angle of 45 degree almost vertically upward from where it could erroneously report back onto the belt. The idler angle must change to 35° below the hammer sampler cutter for material trajectory to be flatter but requires a sample discharge chute with a high ceiling (Figure I & II). Considering the same mechanisms, the sample chute is also elongated in the direction of increment trajectory (Figure I & II) to prevent delimitation error resulting when material bounces back off the sample chute. As a final safeguard against this error mechanism, a durable, weighted, free hanging, natural rubber “dead blow” curtain is supported from the ceiling some centimeters before the vertical receiving wall of the sample chute (Figure 1 & 2) to break the material velocity down sufficiently from 8.1m/s and allow the increment to drop down.

#### Cutter coupling onto shaft

The cutter is designed to be a replaceable wear part. The cutter is flanged and bolts to the shaft’s machined flanges. The assembly is more expensive to manufacture as opposed to complete cutter/shaft/bearing combination replacement but worthwhile considering future ease of maintenance, replacement time and replacement costs of a single part. The design is

deemed necessary given bespoke, expensive shaft design as well as shaft alignment to servo drive motor via the flexible coupling which requires laser alignment tolerances.

Should a “cutter stuck in stream” scenario occur for uncontrolled reasons, the cutter is designed as the sacrificial part over other components of the machine because the cutter cost, ease of replacement and isolation of damage to other components rendered it the lowest impact part. The cutter is designed to warp at its neck below the shaft mounting flange. After controlled failure, the incoming material burden (approaching at 2.7 ton/s design throughput) is allowed to pass without major stream interference that minimizes spillages off the belt.

### Cutter center of gravity

Discrete modelling software from a suitable design package is used to determine the center of gravity and its radius from the shaft center point for the cutter design. These values are used as input into the power requirement calculations of the hammer sampler.

## Power requirements

### Arc available for dynamic phases through cutter rotation

A hammer sampler cutter is typically stopped at (or near) the 12 o'clock position from where gravity contributes to acceleration downward towards the material stream and conversely with deceleration upwards away from the stream (Figure 3). Each sampler rotation has four zones that the cutter passes through: the arc of the cutter width in park position, cutter acceleration, constant speed sampling and deceleration.

The arc available for each zone is determined by the cutter design geometry, belt width and belt radius of curvature and obtained from drawing models. For this design, the available arcs are: 1) cutter arc 78°, 2) acceleration 102°, 3) constant speed 82° and 4) deceleration 98°. The cutter radius of rotation is designed as 1.22764 m. The angular velocity of the cutter ( $\omega$ ) can be calculated using equation [4] and for this design is  $8.1/1.22764 = 6.598$  rad/s. The angular velocity can be converted to revolutions per second (rps) by dividing through  $2\pi$  resulting in 1.050 rps (or 63 revolutions per minute). This means that one complete cutter rotation takes 0.95228 seconds. For this design, the time of the cutter in each of the 3 dynamic zones were:  $(102^\circ/360^\circ) \times 0.95228 = 0.26981$  s acceleration, similarly 0.21619 s constant speed and 0.26188 s deceleration (the cutter arc in park position is not included in the time determination).

### General power requirement

The apparent power required for each of the three hammer sampler dynamic phases can be calculated by the equation for power requirement of a rotating body:  $P = 2\pi nFr$  [2]

P is power (Watt = kg.m<sup>2</sup>/s<sup>3</sup>)

n is revolutions per second (Rev/s)

F is force (N = kg.m/s<sup>2</sup>)

r is radius of applied force F (m)

Then, n is calculated by:  $n = \frac{\omega}{2\pi}$  [3]

And in turn  $\omega$  is calculated by:  $\omega = \frac{v_{cutter}}{R_{cutter}}$  [4]

$\omega$  is angular velocity (radians/s)

$v_{cutter}$  is cutter tip velocity (m/s)

$R_{cutter}$  is cutter tip radius (m)

Writing [4] into [3]:  $n = \frac{\omega}{2\pi} = \frac{1}{2\pi} \frac{v_{cutter}}{R_{cutter}}$  [5]

Writing [5] into [2]:  $P = 2\pi nFr = 2\pi Fr \frac{1}{2\pi} \frac{v_{cutter}}{R_{cutter}} = Fr \frac{v_{cutter}}{R_{cutter}}$  [6]

F is calculated by one of two equations: 1) for the constant speed arc where the force requirement is that required to remove the increment mass from the belt and 2) the force required to accelerate the cutter body mass to the required angular velocity.

### Power to remove the increment from the belt

By Newton's third law, and assuming negligible friction factor and assuming perfect collision conditions, the force to remove the sample increment from the belt is equal in magnitude and opposite in direction to the force required to drive the cutter through the stream at constant velocity, and can be calculated by:  $F_{inc} = m_{inc} a_{inc}$  [7]

$F_{inc}$  is the force to remove increment from belt (N)

$m_{inc}$  -s the mass of increment (kg)

$a_{inc}$  is the required acceleration of increment ( $m/s^2$ )

The increment mass  $m_{inc}$  is calculated by equation [1] listed earlier. By substituting [1] into [7]:

$$F_{inc} = m_{inc} a_{inc} = \frac{W_{cutter} \dot{M}}{3600 v_{belt}} a_{inc} \quad [8]$$

Increment acceleration is calculated by:  $a_{inc} = \frac{\Delta v}{\Delta t} = \frac{v_2 - v_1}{t_2 - t_1}$  [9]

$\Delta v$  is the change in increment velocity (perpendicular to conveyor travel direction) (m/s)

$\Delta t$  is the time taken for velocity change to occur (s)

The initial increment velocity ( $v_1$ ) is 0 m/s, then  $\Delta v \approx v_2$ . For the same reasons  $\Delta t \approx t_2$ . Then [9] becomes:

$$a_{inc} \approx \frac{v_2}{t_2} \quad [10]$$

From the design parameters, we know that  $v_2$  will be equal to 1.5 times belt speed and therefore:

$$a_{inc} = \frac{1.5 v_{belt}}{t_2} \quad [11]$$

We know that  $t_2 = 0.21691$  s and  $a_{inc}$  is calculated to be  $1.5 \cdot 5.4 / 0.21691 = 37.3$   $m/s^2$ . From [8],  $F_{inc}$  is then calculated to be  $257.2 \times 37.3 = 9.593$  kN. With the assumption that the displaced sample increment's center of gravity is at 1.00 m from the shaft center, the power requirement can be calculated with [6] to be 63.3 kW.

### Power to accelerate the cutter from park position to required cut-velocity

Ignoring the contributions of gravitational acceleration as a reasonable design assumption considering the gravitation will assist cutter acceleration downwards towards the stream and reduce force requirement, the torque required for acceleration can be calculated by:  $\tau_{acc} = I \alpha_{acc}$  [12]

$\tau_{acc}$  is the torque required to accelerate rotating components (N)

$I$  is the inertia of rotating components ( $kg \cdot m^2$ )

$\alpha_{acc}$  = angular acceleration of rotating components ( $m/s^2$ )

Then, simplifying the rotating components to be a single component and not a compounded object, the inertia can be calculated by [13]:  $I = m r^2$  [13]

$m$  is the mass of the cutter (kg)

$r$  is the distance of the center of gravity from shaft rotation axis (m)

The simplified cutter inertia works out to be (with a design cutter mass of)  $265 \times (1.22764)^2 = 399.4$   $kg \cdot m^2$ . Next, angular acceleration can be calculated by:

$$\alpha_{acc} = \frac{\omega_2 - \omega_1}{t_2 - t_1} \text{ but with } \omega_1 \text{ and } t_1 \text{ equal to 0 (starting from park position), } \alpha_{acc} \approx \frac{\omega_2}{t_2} \quad [14]$$

The angular acceleration is calculated to be  $6.598 / 0.26981 = 25.454$   $rad/s^2$ .

Now the torque required for acceleration can be calculated with [12] to be  $399.4 \times 25.454 = 10.2$  kN.m.

Next the apparent power is calculated with:

$$P = Fr \frac{v_{cutter}}{R_{cutter}} = \tau_{acc} \frac{v_{cutter}}{R_{cutter}} \quad [15]$$

With resulting  $10.2 \cdot 8.1 / 1.22764 = 67.0$  kW of apparent power required for cutter acceleration.

### Power to accelerate the cutter from park position to required cut-velocity

Following equations 12 through 15 for deceleration, the apparent power is calculated as 66.4 kW.

## Drive system

When the conventional geared motor will not do...

Three reputable global suppliers of geared motors were approached with above power requirements for proposals on a conventional 4 pole motor coupled to a suitable reduction gearbox. The feedback was unanimous, even after special consideration by head offices in Germany and Brazil: that geared motors cannot deliver the torque in the required times and that mechanical reliability of gearbox internal gears is not guaranteed because gear materials can possibly not withstand the shock loads of the application.

### The servo drive and its engineered operational system

Recommendations by a consulting engineer lead to a solution in a high-torque DST2, multi-pole, direct current, electrical, gearless drive from Baúmuller Group. Over its operating range of 0-80 rpm, the selected servo drive model delivers up to 16 kN.m of torque in even faster response times than required without the need for a gearbox. But tis high precision drive comes with its own design considerations and constraints.

A direct current (dc) power supply is required for acceleration and maintaining constant speed through increment extraction. In the detailed design of the project, the power requirements were firmed up (including the effect of gravity and considering the cutter as a compound object) and the cutter acceleration control amended to a logarithmic function (not linear) from the drive's control system to efficiently power it through the 3 dynamic zones. The drive has a factory fitted motor resolver that mechanically monitors the drive output shaft rotation to within fractions of a degree; this monitoring is used by the drive's dc-control system to apply torque control throughout the shaft rotation.

The direct current technology also means that electricity will be generated in the deceleration zone when the hammer cutter acted as a dynamo; a brake resistor bank is employed to dissipate the generated electrical energy to atmosphere as heat energy. Considerations to apply phase control and synchronization to allow the generated electricity to be put back into the grid was considered but in this case is unfeasible given the hammer sampler's low duty cycle of a sample cut once every 5 minutes.

The drive's operational air quality requirement is equivalent to European Union, office environment air quality which is far removed from bauxite ship loading conditions in an equatorial climate. The drive is enclosed with an IP65 enclosure (Figures 1 & 2) and this enclosure fitted with a particulate filtration and moisture absorbing silica gel crystal breather that changes colour upon water saturation. An online relative humidity (and ambient temperature) analyzer is installed to monitor operational conditions within the enclosure.

The servo drive's inherent heat transfer mechanism is designed for continuous running. The hot and humid climatic conditions, high instantaneous ampere drawn coupled with a low duty cycle of the hammer sampler operation determine that the generated heat must be removed from the drive and it's dc- drive system by a forced (pumped) fluid-cooling system. The servo drive's factory fitted thermocouples were used as control loop inputs to control the cooling system. The cooling system has its own process and safety instrumentation and interlocks. The heat transfer design considers the dew point temperatures of the equatorial conditions to prevent moisture condensation in the servo drive internals. Also, the brake resistor heat dissipation is carefully engineered for the hot ambient temperatures and sampler duty cycle.

The precision tolerances between the drive's rotor and stator allows no linear force transfer (other than the intended motor output torque) or misalignment of the servo drive's shaft to within tolerances of 0.5mm vertical, 0.5mm horizontal and 0.25 degree offset. A flexible coupling between hammer sampler through shaft and servo drive output shaft allows torque transfer while decoupling deflection and offset transfer to the drive output shaft. Laser alignment between the two shafts ensures that drive tolerances are met.

### Motor Base

An adjustable motor base allows precision laser alignment between drive stub shaft and hammer through shaft. Simultaneously the motor base frame transfers the torque generated by the servo drive to the hammer sampler main frame. Finite Element Analysis is conducted through design iterations to ensure mechanical rigidity to within +/-0.5mm deflection tolerance of the hammer sampler's cutter to belt gap. All mounting interface surfaces for the servo drive to the motor base and in turn the motor base to the support frame are machined to design tolerances to allow force transfer through the full design area.

### Cutter park brake

The servo drive is not equipped with mechanical park function / brake. The size and inertia of the cutter in free fall would result in fatality if accidentally released from park position when motor loses power or is isolated. Even though the servo drive and its dc-drive allows functionality and control of balancing the cutter in a pendulum park position, this would generate heat which is not dissipated through servo drive rotation (while stationary in park position) and increasing the forced cooling system's duty unnecessarily. A mechanical safety park brake is used in-between 5-minute sample cut intervals. The brake need not be designed to serve as a dynamic stop brake in case of operational emergency because the dedicated dc-drive system controls also the servo drive emergency stop conditions.

### Shaft

An extended, through shaft is designed to rotate the cutter while transferring the necessary drive power to the cutter and mount the park brake on the non-drive end. A suitable shaft material and heat treatment condition is engineered to allow for normal mechanical duties, but further rigidity to within the tolerance of  $\pm 0.5\text{mm}$  over the span of the shaft, as well as withstand the shock load over iterative analysis.

### Bearings

Installation of a hammer sampler onto a sloped conveyor by means of a "shaky suspended bridge" support structure is not recommended (Pitard, 2005<sup>2</sup>). This statement is elaborated here considering the force vector down the conveyor slope that will be generated by a hammer sampler rotation where the sampler is not installed horizontally.

Over and above the normal bearing loads (perpendicular to shaft axis) of this heavy duty application and alignment tolerances, selected thrust bearings are required to withstand the force vector generated down the plane of the inclined conveyor that the sampler is mounted on (parallel to the shaft). These bearings are packed in plumber blocks. The bottom mounting surfaces of the plumber blocks must be designed to undergo additional manufacturing to be machined flat, post reliable OEM factory supply. The machined plumber blocks are bolted into plumber block seats which must also be machined to tolerance to ensure proper plumber block seating in the hammer sampler's support frame. Without machine surface interfaces, the force transfer available area might be compromised outside of design limits.

### Housing

Pitard (2005<sup>2</sup>) acknowledges the importance of the (seemingly simple plate work) housing design as an integral part to the working and potential accuracy of a hammer sampler by recommending:

- Generous and safe inspection hatches (Figure 5) to allow maintenance inspection of wear parts to ensure design conditions are maintained,
- Eliminate delimitation and extraction errors by isolating and containing flung material from high velocity vector cutter-with-stream interaction through (refer Figures 1, 2 and 5):
- Generous ceiling design to contain material trajectory.
- Sufficient sample chute length to prevent sample increment bouncing back onto the conveyor.
- The addition of skirts and curtains that isolate sample material form unintended material sampling.
- In this case, the addition of a dead blow curtain to break sample increment velocity.

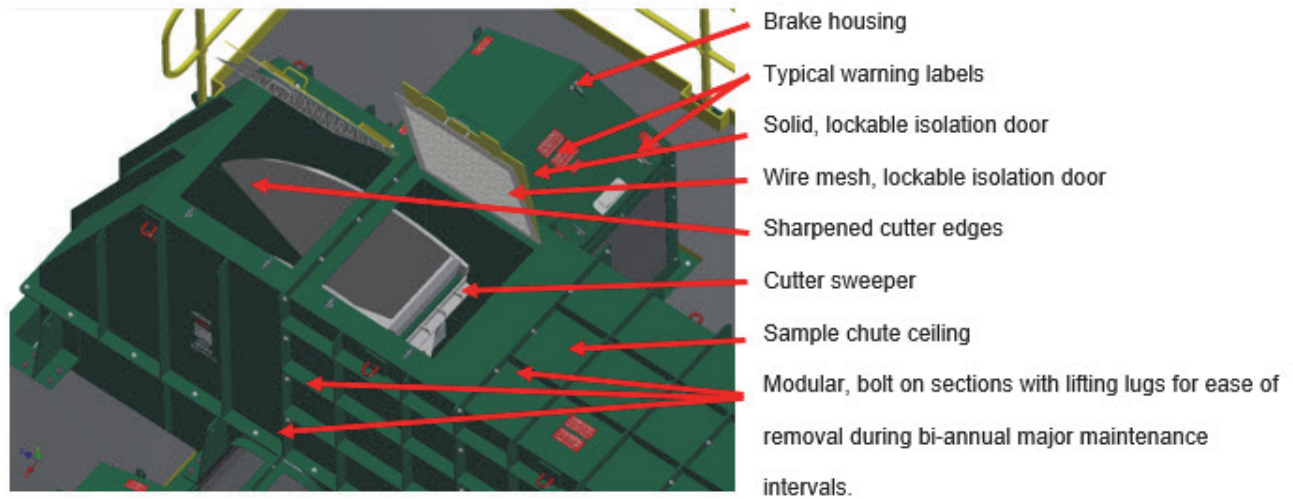

**Figure 5. Housing design including multiple maintenance inspection hatches that are accessible to inspection, too small to climb through and safe: with double lockout possibility of solid door and/or expanded metal mesh screens.**

Other outcomes of the housing are protecting operators against the rotating components (also display warning labels in English and operator first language option) and to protect machine components from external damage. All the above is included in the hammer sampler design. The housing of this design did contribute to overall machine static loads but did not contribute to stiffening of the structure which is all designed into the support frame. A client design request is to add additional low friction Tivar 88, abrasion resistant, 3% w/w glass bead laced liners into the sample chute to assist with sticky material discharge.

### Frame

The frame transfers the torque induced forces from the motor, through the motor base, to the hammer support structure and then into concrete pilons into the ground.

Critical parts of the drive train were bolted to the frame where both interface surfaces of the frame and the components are machined to tolerances to allow full area for force transfer. Seating surface areas are used in FEA design iterations to ensure deflection tolerances of  $\pm 0.5\text{mm}$  overall were met.

The resulting force transfer through the sampler frame's 10 feet mounting positions cannot be accommodated into the existing client conveyor's stringers. The engineering requirement is to build a suitable, independently grounded, support structure that straddles the client conveyor. This structure must support the hammer sampler 14 meter above ground level, must successfully transfer the generated machine force into concrete pilons driven into the swamp-like soil conditions – all while stiff enough to comply with the overall 0.5mm tolerance and last through cyclic operation.

The decision is taken to mount the ten hammer sampler feet onto two girders with 5 receiving pads each. These pads are machined across the length of the girder in a single milling action to ensure the alignment between hammer sampler shaft center and conveyor center line fell within the project design tolerance. The girders were in turn mounted to the hammer support structure.

### Safety features

The mechanical safety features of the machine design are:

- The housing which guards operators against rotating components and machine parts against external damage.
- Individually lockable, solid and expanded metal mesh maintenance inspection hatches.
- Mechanical park brake.
- Audiovisual alarm before sampling plant start up.
- Hardwired emergency stop

Safety interlocks are:

- Emergency Stop activated or engaged.
- dc-Drive system ready
- dc-Drive Fault
- Cooling fluid heat sink chiller fault
- Internal motor temperature

Process interlocks are:

- Profile detector that prevents large lumps / abnormally high material burdens to be sampled outside of design intent.
- Cutter park position proximity switch flags a fault if the cutter is delayed or never reaches the park position
- Sample chute blocked chute detector delays / prevents the sampler from taking another sample cut
- Moisture analyser to delay / prevent sampling material with moisture higher than the TML that will choke up the downstream sampling plant
- Production conveyor running to prevent a sample cut until client conveyor is operational
- Additional dc-Drive process interlocks are considered as proprietary information
- A metal detector interlock is recommended to prevent damage from sampling rigid steel tramp

### Control and instrumentation

The entire sampling plant infrastructure, drives, instruments, interlocks and sequencing is controlled via a Siemens Programmable Logic Controller (PLC). The hammer sampler however, required such fast response times that its own proprietary logic controller is used as a dedicated fast response processor located within the dc-drive unit.

At ISO 8685:1992 compliant primary sampling intervals of 5 minutes, the PLC would evaluate system healthy conditions and if confirmed, will prompt the dc-drive controller to take a sample cut. The dedicated controller would take control of hammer sampler rotation and once successfully completed, would relay a signal back to the PLC that a successful cut is taken.

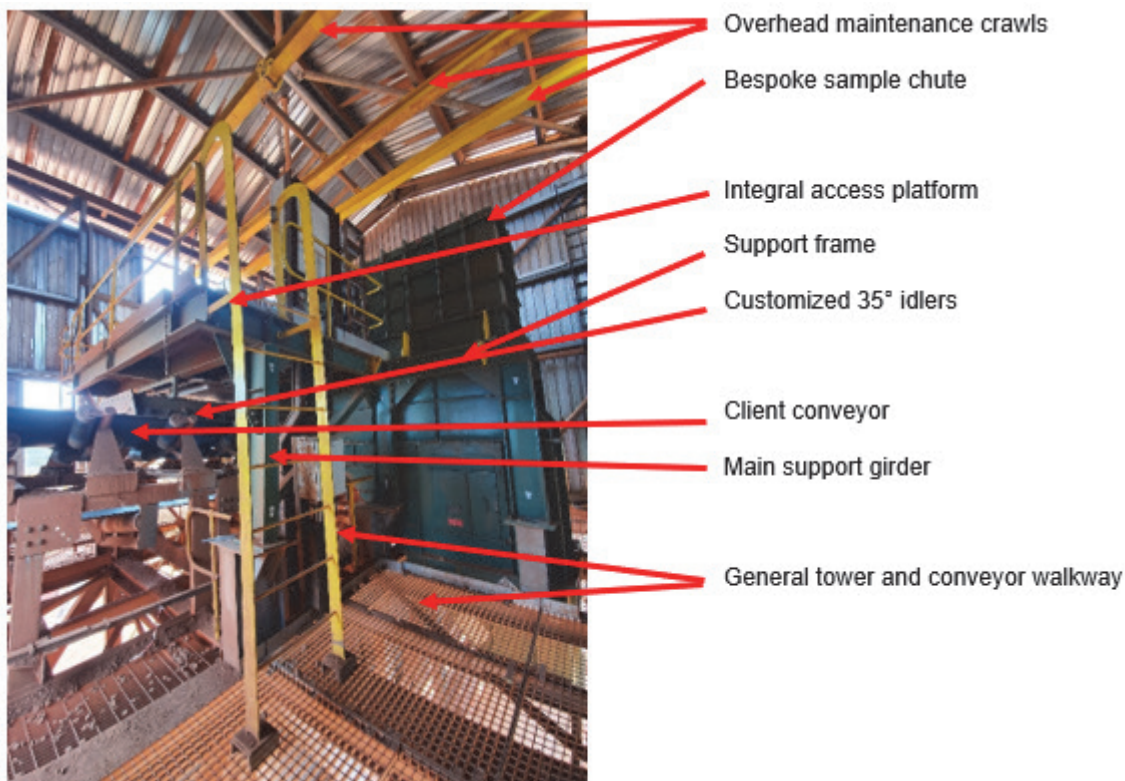

**Figure 6.** A photo of the installed and operational, world's largest hammer sampler showing some featured components and integration over the client conveyor. The technical design team nicknamed the machine Mjöltnir, according to Norse mythology: the name of Thor's trusted hammer.



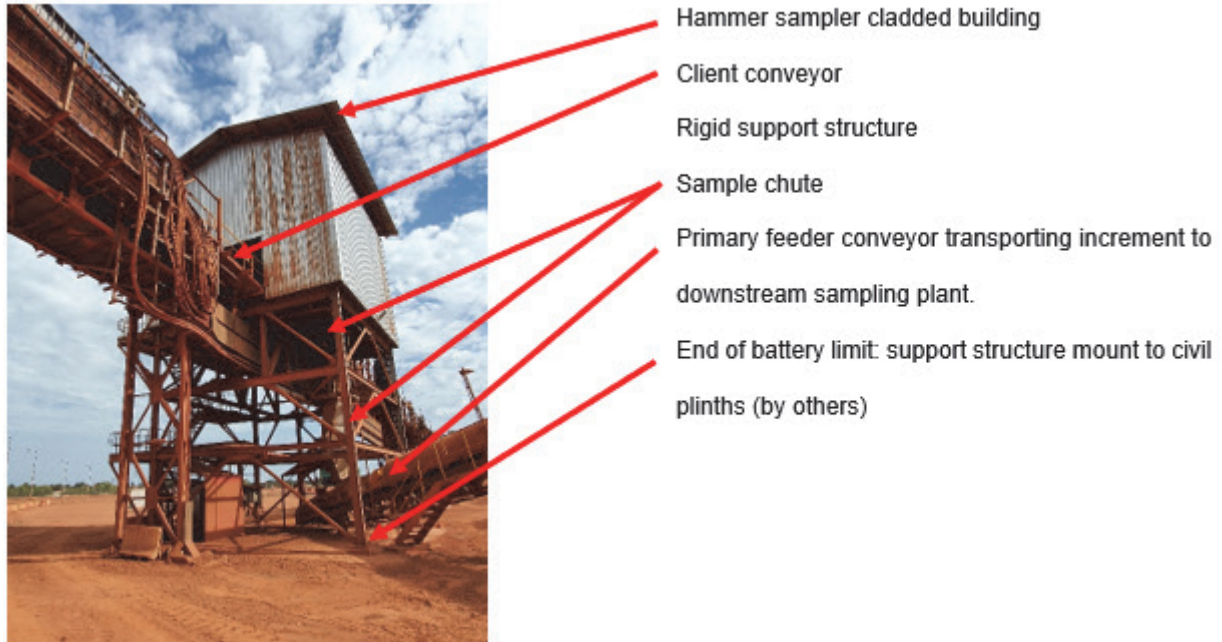
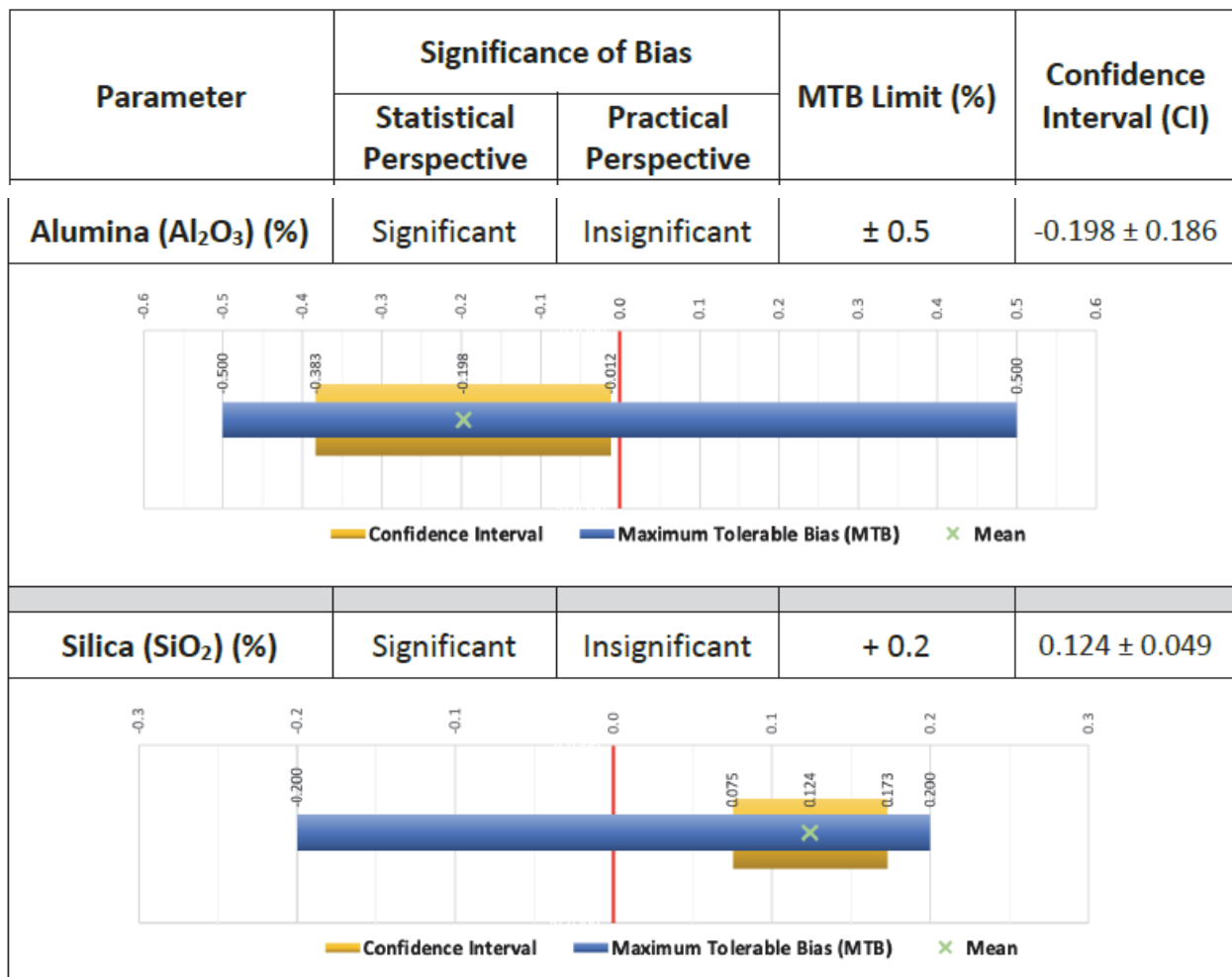

Figure 7. A photo of the installed hammer sampler's 14-meter-high tower, i.e. Mjölínir's home.

### Performance – bias testing

The sampling plant, sample preparation and analytical procedures were bias tested 6 months after commissioning, by an independent, experienced third party. The bias test results can be seen in Figure 8 below. The reference samples were extracted from the stopped production conveyor as per standard industry practice and in compliance to ISO – 10226 Aluminium ores – experimental methods for checking the bias of sampling<sup>7</sup>. The composite chemical sample results were compared to the profile plate reference belts cuts over 60 sample sets (one set comprising the composite system sample and reference samples A and B). No separate bias testing of the primary sampler was conducted – only the entire sampling plant performance was tested.



**Figure 8. Bias testing results of the sampling scheme showing client specified Maximum Tolerable Bias Level (MTB) with the blue line, bias test results with the yellow line.**

Bias detection was done in accordance to ISO – 10226<sup>7</sup>. A bias from a statistical perspective was observed where the average and standard deviation (position and span of the yellow line) does not intercept zero. However, from a practical point of view the data renders the bias irrelevant since the confidence interval falls within the MTB limits set out by the client as applicable to their commercial trade parameters.

Silica grade is overreported against the reference samples. The client informed that the Silica grade reports in the fine fraction. This implies that fines are oversampled in their proportion in relation to the Aluminium bearing coarser material. This finding is in direct contradiction to claims that hammer samplers tend to leave fines on the belt. An isolated bias test on the primary hammer sampler only (not the entire sampling plant) would be a more conclusive basis to support this claim.

Aluminium grade was slightly underreported while Silica content slightly overreported against the “truth” (reference samples). If the seller of bauxite is faced with a contractual claim for quality (low Aluminium content or high Silica content), the under and over reporting of respective elements would act in the bauxite seller’s favor to defend the claim when explaining that the sampling plant values are conservative on each quality parameter.

### Conclusions

Revenue risk and reputational damage to mineral trading parties demands key and correct, representative, automated mechanical samplers compliant to TOS as essential. The absence of detailed mechanical design criteria in most international standards (that commercial transactions are based on) requires client, engineering houses and the SEM to uphold their responsibilities to sampling projects that successfully meet their quality assurance intent. These projects will often result in multi-discipline engineering projects which must not be underestimated in complexity and cost during budgeting, detailed design and execution. Where cross stream samplers are not practical given independent projects’ circumstances, hammer samplers are proven to be a viable alternative if designed correctly.

The accuracy and precision levels (representativeness) required for this metal accounting application required revisited consideration of all published error generating mechanisms and minimizing their effect through component-design and

hammer sampler integration into the plant infrastructure. The cutter angle (straight versus skew), geometry, capacity, width and speed are influential design parameters. However, the selected 5mm gap between cutter and belt was paramount and dictated not only that the client conveyor parameters had to be changed to a smooth profile, 35° idler angle curvature– but also that the installed hammer sampler and all its components had to be designed to a tolerance of  $\pm 0.5$ mm dynamic deflection. This tolerance concluded that a 15 ton hammer sampler, capable of 16 kN.m of torque in 0.748 seconds, installed on an inclined belt, 14m above ground level, on its own support structure straddling the production conveyor has to be aligned overall to a tolerance of  $\pm 0.5$ mm. This engineering feat that was achieved, even though more costly than conventional hammer sampler installation. The client's strict requirement to be a reputable, quality assured mineral supplier overcame quality (prototype concerns, technical concerns and most importantly prior unreliable SEM influences), speed (project deadlines) and cost influences to support the successful implementation of the world's largest hammer sampler.

A bias from a statistical perspective is observed, but from a practical point of view, the standard deviation is low and falls within the minimum tolerable bias limits set by the client. Verification of the performance and material variances using variographic analysis according to methods described in DS 3077 (2013<sup>5</sup>) is recommended for future work.

The combined material parameters, conveyor parameters (particularly belt speed) and hammer sampler component mechanical design, results in a drive system power requirement that was unique and cannot be achieved with conventional induction motors and gearboxes. An existing servo-drive technology was pioneered in this application because it was the only known available option; even though its own considerations and constraints added complexity to the system it was successfully integrated and now boasts functionality of torque control and precision monitoring that is invaluable to its application.

## References

1. Steinhaus, R.C., and Minnitt, R.C.A. 2014. "Mechanical Sampling - a Manufacturer's Perspective". *The Journal of The Southern African Institute of Mining and Metallurgy*, vol. 114, January 2014. pp 121-130.
2. Pitard, F. 2005. "Sampling Correctness – A Comprehensive Guideline". *Sampling and Blending Conference, Sunshine Coast, QLD, 9 - 12 May 2005*.
3. Robinson, G.K., Sinnott, M.D., and Cleary, P.W. 2008. "Can Cross-Belt Cutters be Trusted?" *Sampling Conference, Perth, WA, 27 - 29 May 2008*.
4. International Organization for Standardization. (1992). Aluminium Ores – Sampling Procedures – (ISO 8685:1992(E)).
5. Danish Standards Foundation. (2013). Representative Sampling Horizontal Standard – (DS 3077:3013).
6. Rose, C.D. 2012. "Bias testing of mechanical sampling systems for coal – a review of test results". *Sampling 2012: The Critical Role of Sampling, Perth, WA, 21-22 August 2012*. Publication series no. 7/2012.
7. International Organization for Standardization. (1991). Aluminium Ores – Experimental methods for checking bias of sampling – (ISO 10226:1991).

## Fake Data? The Need for Theory of Sampling Concepts in Environmental Research and Investigations

\*R. Brewer<sup>a</sup>, C. Ramsey<sup>b</sup>, M. Heskett<sup>c</sup>, J. Song<sup>d</sup>,

<sup>a</sup>Senior Geologist/Environmental Scientist, Hawaii Department of Health, 2785 Waimano Home Road, Suite #100, Pearl City, Hawai'i 96782, United States of America. Email: roger.brewer@doh.hawaii.gov

<sup>b</sup>President, EnviroStat, Inc., P.O. Box 339, Vail, Arizona 85641, United States of America. Email: chuck@envirostat.org

<sup>c</sup>Senior Scientist, Element Environmental, 98-030 Hekaha St Unit 9, Aiea, Hawai'i 96701, United States of America. Email: mheskett@e2hi.com

<sup>d</sup>Professor, Institute of Soil Science, Chinese Academy of Sciences, No. 71 East Beijing Road, Nanjing, Peoples Republic of China, Post Code: 210008. Email: jingsong@issas.ac.cn

**Abstract:** The sampling intensive mining and environmental industries share a common need for representative data but differ in the motivations to accomplish this objective. The desire to obtain representative sample data for “commodities” in the mining industry is driven by anticipated economic gain and the exploitation of natural resources. The desire to obtain representative sample data for “contaminants” in the environmental industry is driven by anticipated social gain and the protection of natural resources. In terms of obtaining reliably representative data, motivation driven by economic gain has thus far been the clear winner. Theory of Sampling concepts are well established and tested in the mining industry. The environmental industry, in contrast, has traditionally been plagued by scientifically unsound sampling practices and data that are not reliably representative of conditions in the field. This has significant implications for topics ranging from the efficient identification and remediation of contaminated industrial lands to the accurate assessment of risk to human health and the environment.

This paper explores the nature and cause of this dichotomy and presents a methodical approach for application of Theory of Sampling concepts to environmental testing of soil, water and air. Much of the problem is tied to a general recognition of compositional and distributional heterogeneity in contaminated media but unawareness of a method to control it or an understanding of the magnitude of potential error. As a result, published regulatory guidance focused on classical sampling and statistical methods appropriate for testing of “finite element” media. A lone exception is testing of indoor air, where concepts of “Decision Units” and sampling methods more appropriate for testing of “infinite element” media have long been employed to control and represent heterogeneity.

The solutions are, in hindsight, relatively simple. Pushback from affected parties and even scientists and environmental agencies can be significant, however. This is primarily due to a lack of training of environmental professionals in the Theory of Sampling and the common absence of clear evidence of erroneous or misleading sample data in the field. Reluctance to change is also tied in some cases to implications regarding liability for past and ongoing projects. The need for more reliable, efficient and science-based methods to assess and address risk posed by environmental contamination is clear, however. Progress will be made by countries like China that are beginning to tackle legacies of early development and are able to learn from the successes as well as the mistakes of countries that have been addressing environmental contamination for several decades. Training of environmental workers as well as pressure from liability-savvy responsible parties, attorneys and financial institutions will continue to force the industry to evolve, to the benefit of the environment as well as stakeholders on all sides.

### Introduction

Similar stages of investigation are common to both the mining industry and the environmental industry in their efforts to identify and take action on anomalously high concentrations of chemicals in the environment (Figure 1). The process begins in the mining industry with geologic mapping or ore bodies and ends with extraction and marketing of the targeted “commodity.” The process begins in the environmental industry with preparation of a Conceptual Site Model (CSM) of the extent and magnitude of impacts and ends with destruction or isolation of the targeted “contaminant.” In each case, samples are collected, processed and tested and the resulting data used to make decisions regarding the economic extraction of the commodity or the risk to human health and the environment posed by the contaminant.

The success of both industries relies on the efficient and reliable collection of representative sample data. In the mining industry, extraction and measurement of the true mass of the commodity present in crushed ore allows the accuracy of the data and the sampling method employed to be routinely tested. Economic and business repercussions for data error are severe and quickly realized by those responsible for directing the collection of sample data. Such economic incentives combined with an intense dedication to the science of sampling led to a progressive evolution and improvement in the

collection, processing and testing of samples that ultimately came to be referred to as Gy's Theory of Sampling<sup>1,2,3,4</sup> (see also 5,6).

A correlative pressure to identify and address sampling error in the environmental industry has been lacking, due in large part to two factors: 1) Lack of routine extraction and direct measurement of the mass of the contaminant present in the targeted media which would directly identify sample error and 2) Oversight and direction of sampling methods by government agencies largely shielded from repercussions of erroneous or misleading data and decision making. Some degree of "third-party" verification of data reliability exists in operations to extract volatile contaminants from soil or to otherwise treat and destroy contaminants in situ. Remediation experts typically over engineer the design of a remedial action at significant added cost in order to address uncertainty in the sample data. Discrepancies in the mass of contaminant extracted and the mass initially predicted by sample data is often attributed to "laboratory error," however, rather than to mistakes in the field.

The disconnection of government agencies from unnecessary legal and economic damage inflicted on regulated entities has hindered serious, scientific review of the nature and source of errors and improvement of sampling methods. Basic concepts of Gy's Theory of Sampling and related sampling methodologies used in the mining industry since the 1950s can, however, help address lapses in the environmental industry and improve the reliability of data used in research and routine investigations.

## Traditional Environmental Sampling Methods

### Testing of Soil, Water and Subsurface Vapors

Soil and water sampling guidance was initially published by the United States Environmental Protection Agency (USEPA) in the 1980s, following passage of the Resource Conservation and Restoration Act<sup>7,8,9,10</sup> (see also 11). The Superfund program and other offices within the USEPA were tasked with developing guidance for characterization of the extent and magnitude of contamination in soil, sediment and other media. Concurrent guidance<sup>12,13,14</sup> for quantitative assessment of health risk emphasized the need to estimate a mean contaminant concentration for a targeted "Exposure Area".

A detailed overview of the evolution of soil and sediment sampling guidance in the environmental industry is provided by Brewer et al<sup>15,16</sup>. Early environmental guidance for site characterization focused on the collection and individual testing of small, discrete samples of soil and water with the mass or volume of the sample dictated only by the minimum mass required by the laboratory for testing. This typically required the collection of only 100 to 300 grams of soil and a few liters to as little as 40 milliliters of water. This is likely due to experience of the early authors with testing of relatively uniform, industrial wastewater. Concentrations of contaminants within relatively small volumes of water can be assumed to be consistent provided that operations within the manufacturing facility do not change.

Reliance on testing of small-mass or small-volume, discrete samples from a single point characterize contaminant distribution within a targeted media necessarily requires an assumed lack of significant, variability over very short distances and even within the same sample. This assumption is clearly stated in guidance for environmental testing of soil and sediment:

"The implicit assumption that residual contamination is equally likely to be present [at similar concentrations] anywhere within the sampling area is reasonable"<sup>7</sup>.

"To apply this [discrete sampling] method, the following assumptions are required... The shape and size of the contaminated zone must be known at least approximately. Any sample located within the contaminated zone will identify the contamination. These assumptions are not severe and should be met in practice"<sup>8</sup>.

"When there is little distance between points it is [assumed] that there will be little variability between points"<sup>14</sup>.

Distributional heterogeneity as well as compositional heterogeneity within samples of soil and other particulate matter is largely ignored at the laboratory. Minimal to no processing of samples is required before collection of a subsample for testing. Subsamples are collected at random from a single point within the sample submitted. The mass of subsample is intentionally minimized to the extent possible in order to minimize reagents and waste and to shrink benchtop automated systems, with as little as half a gram of unground material tested in some cases. Validation of sample data quality only focuses on the reproducibility of the laboratory method itself rather than the representativeness of the subsample tested. Discrepancies between duplicate laboratory subsamples or field samples is normally resolved by simply using the higher concentration.

Warnings were raised within the USEPA regarding the unreliability of individual discrete sample data points for determining the extent of contamination in the field, including<sup>17</sup> (see also 18,19):

"Grab samples' or judgmental samples lack the component of correctness; therefore, they are biased. The so-called grab sample is not really a sample but a specimen of the material that may or may not be representative of the sampling unit. Great care must be exercised when interpreting the meaning of these samples."

The fact that the prescribed sampling approaches for soil might prove in the future to be unreliable was not lost to the authors<sup>14</sup>:

“Future changes in EPA policy may invalidate some of the discussions in this (guidance).”

Detailed field and laboratory studies have indeed demonstrated significant and random distributional and compositional heterogeneity in contaminated soil as well as other particulate matter<sup>15,16</sup>. High variability between sample data hinders the precision of classical statistical tests to estimate a mean contaminant concentration for assessment of risk. In order to address this issue, environmental risk assessment erroneously recommends that high-concentration “outlier” data be ignored<sup>20</sup>. Error in sample data collected and tested in this manner is, as a result, unknowable. The potential for significant underestimation of the mean is apparent, however, by the common need to over engineer *in situ* treatment systems by experienced remediation experts in order to accommodate an anticipated order-of-magnitude or more actual mass of contaminant present than predicted by discrete sample data.

Guidance documents for testing of groundwater<sup>9</sup> (e.g., to assess drinking water aquifer risk) and guidance for testing of vapors from volatile chemicals immediately beneath the slabs of buildings (“subslab vapors”)<sup>21,22,23</sup> (e.g., to assess vapor intrusion risk and impacts to indoor air) similarly rely on an undemonstrated assumption of negligible, distributional heterogeneity over short distances and recommendations for individual testing of widely-spaced small-volume, discrete samples:

“(Groundwater) samples taken in close proximity (e.g., within a few meters)... are highly auto-correlated. ...Dense spatial monitoring... runs the risk of redundant data”<sup>9</sup>;

“The default (indoor air:subslab vapor attenuation factors) assume (that) ...the subsurface (vapor plume) is reasonably homogeneous”<sup>22</sup>.

Detailed field studies of the nature of random, distributional heterogeneity of contaminants in groundwater have never been carried out to the knowledge of the authors. Such localized variability is inevitable, however, given the inherent heterogeneous nature of soil. The variability of contaminant concentrations in subslab vapor plumes over very short distances is, in contrast, well documented<sup>24,25</sup>. As stated by Luo et al.<sup>26</sup> in reference to the use of single samples to estimate attenuation factors:

“Random sampling of a few locations might not reveal the true range of concentrations... Even if one had precise knowledge of the subslab soil-gas distribution, it is not clear how it would be used to assess pathway significance without knowledge of the vapor entry points to the building and soil-gas entry rates through those points.”

An especially egregious example is USEPA’s “Empirical Database” of the attenuation of intruding, subslab vapors in indoor air<sup>27</sup>. Subslab vapor and indoor air data were compiled for hundreds of structures. Data for a single, small-volume (typically one liter) sample of subslab vapors was compared to data for indoor air and used to generate an indoor air:subslab attenuation factor for the structure. Apparent attenuation factors calculated from the database were spread over five orders of magnitude, even though the structures involved were reasonably similar. Statistical tests were carried out on the database in an attempt to make sense of the data, with the 95% Upper Confidence Level of the mean selected for use in regulatory guidance. The total error associated with the USEPA database is impossible to quantify and the proposed attenuation factor scientifically invalid. Discrepancies between impacts to indoor air predicted by the default attenuation factor and actual field measurements led some workers to simplistically declare that the physics involved in vapor intrusion was “wrong,” rather than consider that the data collected were in fact unrepresentative.

The potential for localized and random, distributional heterogeneity of contaminants within the targeted area and volume of surface water is recognized in sampling guidance<sup>28</sup>:

“The probability is small that any body of still water (lake, reservoir, pond, lock, storage pool) is relatively homogeneous with regard to any water-quality characteristic. Therefore, a single sampling point generally is not adequate to describe the physical and chemical properties of the water body, or the distribution and abundance of the inhabiting biological community.”

The collection and individual testing of discrete samples was still called for, however<sup>28</sup>:

“Still-water samples generally also are collected at multiple locations in the water body and at multiple depths...”

The number of sampling locations selected and the depths where samples will be collected depend on study objectives and the physical, chemical, and biological characteristics of the water body.”

Statistical tests were to be used to estimate mean contaminant concentrations for targeted bodies of groundwater or groundwater extracted from a single well. In the absence of replicate sets of sample data, however, the representativeness of a single set of discrete sample data for a targeted volume of water as a whole will remain uncertain.

Such lapses did not go entirely unrecognized by early environmental professionals. A small number of scientists within the USEPA pushed internally for consideration of sampling methods familiar to the mining industry at contaminated sites soon after initial guidance was published but with limited success<sup>29, 30 (see 16)</sup>. As discussed by the authors of USEPA guidance for the collection of representative subsamples at the laboratory<sup>30</sup>:

“It soon became clear that sampling is perhaps the major source of error in the measurement process, and, potentially, sampling [including the collection of laboratory subsamples] is an overwhelming source of error for

heterogeneous particulate materials, such as soils. It was also clear that classical statistical sampling theory was not adequate for such samples... We knew that geostatistics offered some answers, such as the sample support (mass, volume, and orientation) and particle size (diameter) make a difference. That is only common sense... We searched for a non-conventional statistical sampling theory that actually takes into account the nature of particulate materials and, in 1989, we hit "pay dirt," ...the Pierre Gy sampling theory for particulate materials. ...Over the ensuing years, we were only moderately successful at transferring this technology to the environmental community so that it might be implemented."

These and other examples of data error in the environmental industry's reliance on discrete sample data for decision making have caused significant financial and legal hardships for entities tasked with carrying out investigation and remedial actions, including:

- Repeated need to collect additional sample data with no clear end point;
- Significant time delays and cost overruns for site characterization and remediation;
- Liability associated with contamination discovered on supposedly remediated properties; and
- Unnecessarily abandoned properties sites later found to still be contaminated.

With only a few exceptions, this struggle to incorporate sound science into the environmental industry continues thirty years later but in recent times has made progress.

### Testing of Indoor Air

An exception to the above noted problems in the environmental industry is traditional method used to test indoor air. Although not specifically described as such, Theory of Sampling type concepts have long been incorporated into testing of indoor air quality. A typical Investigation Question might be: "Does the mean concentration of contaminant 'X' in the air circulating through this room during time period 'Y' exceed screening level or target risk level 'Z'?" The volume targeted for sample collect is calculated as the volume of the indoor space times the measured or estimated indoor air exchange rate times the designated time period. For example, 2,050,000 liters of air are predicted to circulate within a default, single family home with a volume of 244 cubic meters<sup>31</sup> and a minimum-recommended indoor air exchange rate of 0.35 times per hour<sup>32</sup> over a 24-hour time period. Risk is assessed by comparison of the mean concentration of the target compound in the air to a screening level pertinent to the exposure scenario or by incorporating the data into a human health risk assessment.

The collection and testing of single or multiple, instantaneous, discrete samples of indoor air is rarely if ever done. The sampling device is instead placed within the targeted indoor area and allowed to collect a continuous sample throughout the designated exposure period. Air flowing past the device is assumed to be representative of air circulating within the DU as a whole. One of three methods is typically used to collect a sample: 1) Whole air sampling; 2) Sorbent tube sampling and 3) Passive sampling using sorbent materials. The first two methods are referred to as active sampling<sup>33</sup>. Whole air sampling involves the collection of air in a sample container over a specified time interval, such as a Summa canister or a Tedlar bag, and analyzing the gas from that container directly<sup>34</sup>. In the second method, a pump or syringe is used to pull air through a tube containing a sorbent material<sup>35</sup>. The concentration of the chemical in air is determined by dividing the mass of the chemical sorbed to the material by the volume of air pulled through the tube. Passive sampling involves placing an adsorbent material in the targeted DU area and allowing compounds in the air to sorb to the material over the targeted time period without the use of a pump or a Summa canister<sup>36</sup>.

This approach to testing of indoor air fits well into Theory of Sampling concepts regarding the collection of a single sample that is reliably representative of a very large volume of infinite element media. The sample is normally collected over a time period of one to five days and during hours when the structure is occupied (e.g., 24 hours a day for residences and during working hours for commercial buildings). The resulting data are assumed to be representative of long-term, indoor air quality. Replicate samplers can be placed in independent areas of the targeted indoor area and/or on different days in order to test the precision of the data collected. Similar concepts of the collection of small samples that are directly representative of very large volumes of environmental media can also be applied to soil, water and even subsurface vapors.

## Application of Mining Industry Concepts to the Environmental Industry

### Systematic Planning

Detailed guidance on the application of Theory of Sampling concepts to testing of soil, sediment, water and subsurface vapors has been in use by the State of Hawaii for over ten years<sup>37</sup>. Guidance specific to the investigation of contaminated soil has recently been published by the Chinese Academy of Sciences<sup>38</sup>. The following presents a summary of these and related guidance documents.

Careful, systematic planning of an environmental investigation is necessary to ensure that the data collected reliably address the investigation objectives. The process centers on a basic but methodical series of questions applicable to any

type of investigation:

- What is the media of interest?
- What is the contaminant(s) of potential concern (COPC)?
- What is the specific Investigation Question?
- What is the Decision Unit(s)?
- How can a representative sample of the DU be collected?

A Decision Unit (DU) is defined as the area and volume of targeted media about which a decision is to be made<sup>37,38</sup>. In the environmental industry, such decisions typically reflect the assessment of risk or optimization of remedial actions. Efficient designation of DUs for sample collection requires the development of specific Investigation Questions beyond the simplistic determination of the presence or absence of contamination, for example: “Does the concentration of ‘X’ in the media ‘Y’ exceed a target screening level or health risk of ‘Z’?” This is most commonly assessed based on comparison of data representative of the mean concentration of the COPC for the DU to a published or site-specific, risk-based screening level. If an adverse risk is already known, then the Investigation Question might be “What is the location of the main mass of contamination that will require remediation to address risk?”

Initial preparation of the scope of an investigation begins with a review of the site history and available environmental data. This is used to prepare a preliminary Conceptual Site Model (CSM) of suspected conditions, identify COPCs, develop specific investigation questions and determine data needs. The site is then divided into well-thought-out risk- or remediation-based DUs and a detailed SAP prepared. When the data are made available, a thorough data quality review is carried out to confirm that samples were properly collected, processed and tested and that data for replicate samples met data quality criteria. When an acceptable level of confidence in the data is reached, the environmental risk is assessed, the CSM updated as needed and recommendations for additional actions proposed.

A key part of the Systematic Planning process is the development of DU decision statements that specify how sample data will be used for decision making. This is done *prior to* the collection of samples and agreed upon by the field workers, risk assessors and remediation experts involved in the project. An example might include “If Contaminant ‘X’ in soil exceeds Screening Level ‘Z’ then the DU volume of material will be excavated and disposed of in a regulated landfill.” Investigations are intentionally designed in a manner that minimizes the need for remobilization and collection of additional samples. This can be accomplished with proper forethought and planning.

### Sampling Error Control

Controlling data error is critical to making reliable decisions. Potential error associated with the collection of samples in the field and subsamples for testing in the laboratory is in part related to the compositional and distributional heterogeneity of the media of interest<sup>2,3,4,5,6</sup> (Figure 2). Compositional heterogeneity or “Fundamental Error” refers to variability between individual particles and is described in terms of particle size, shape and density (Figure 2a). Other characteristics of importance include whether the contaminant of interest is bound up within individual particles or fully liberated and present as individual nuggets.

Error associated with compositional heterogeneity is controlled through the collection of an adequate mass of material. Compositional heterogeneity is relatively easy to control in testing of air and water due to the smaller particle size but plays an important role in testing of particulate matter. In the case of soil, defined as particles equal to or less than two millimeters in diameter, a minimum subsample mass for testing of 30 grams is required to reliably address Fundamental Error<sup>37,38</sup>. Smaller subsample masses can be acceptable for finer-grained material, but testing of a minimum of 10 grams of material is required for any particle-size material that has not been thoroughly ground.

Distributional heterogeneity refers to variability of the mean concentration of a contaminant within the project site as well as within individually targeted DUs and even the sample collected from a DU and submitted for processing and testing (Figure 2b). Division of a project site into DUs in order to isolate heavy contamination and optimize remedial efforts requires a preliminary estimate of distributional heterogeneity based on historical information and available data. This must be carried out at a scale that is cost-beneficial for the project as a whole. Excessively large DUs could lead to unnecessary cost for treatment of otherwise clean material. Excessively small DUs could lead to unnecessary time and effort in the field with no benefit for successful completion of the project.

Distributional heterogeneity, described by Gy as Grouping and Segregation Error, plays an important role in all types of environmental media and is the main cause of data error in research and regulatory field investigations. Other types of sampling error pertinent to environmental investigations include designation of increment collection points (Increment Delimitation Error) and collection of sample increments in the field (Increment Extraction Error); sample processing at the laboratory (Preparation Error) and error associated with analysis of a subsample (Analytical Error). Analytical error is often considered the primary concern for data variability. Analytical error is generally minor, however, in comparison to sample collection and processing error<sup>1,4</sup>.



### Testing of “Finite Element” Versus “Infinite Element” Media

Proper collection of samples in the field is required to obtain representative data. Media targeted for sample collection can be defined as “finite element” or “infinite element”<sup>38,40</sup>. “Elements” are defined as the individual components that comprise a material, for example particles of minerals and organic material that make up soil and individual molecules that make up liquids and vapors. Finite element media are defined as media composed of elements that can be individually identified and individually selected at random. Examples include room of people, forest of trees, cans of tuna, bags of rice, bags of soil, bottles of water, etc. Data Quality Objectives (DQOs) for sample collection typically include the need to assess variability between individual elements (e.g., people or packages) or estimate “minimum,” “maximum” or other quality control parameters. Data are compiled by are collecting and independently testing individual elements. The elements collected in total represent the “sample.” Traditional statistical tests are used to compile the desired DQOs. The only variable of concern is the number of elements selected. Variability between individual elements is used to assess the overall precision of the estimated parameter values.

Infinite element media are defined as media composed of elements that cannot realistically be individually identified or individually selected at random for testing. Examples include a pile of flour, rice or soil as well as a pool of water or a room of air. Vapor in unsaturated pore space in soil immediately beneath the slab of a building, often the focus of environmental investigations associated with “vapor intrusion,” also represents a form of “infinite element media. The primary DQO associated with testing of these types of media is always determination of the mean or “true” concentration of the specified chemical or other parameter for the DU area and volume of material as a whole. Data are compiled by collecting and combining groups or “increments” of individual elements into single, bulk sample for processing and testing<sup>37,38</sup>. Variables of concern include the number of increments used to prepare the sample, the method used to collect the increment and the total mass of the resulting sample. Data for independent, replicate samples collected from a portion of the project DUs are used to test the overall precision of the sampling method. The precision of replicate sample data in combination with a review of the final sampling collection and processing methods is used to assess the overall quality and reliability of sample data for decision making.

A historical mistake in the environmental industry, as described above, has been to apply “discrete” sampling methods appropriate to finite element media to testing of infinite element media such as air, water and soil. As a result, the data provided by the laboratory are not reliably representative of the sample provided and the sample provided is not reliability representative of the area and volume of media that it was collected from. This is the crux of the problem with traditional sampling methods employed by the environmental industry.

## Collection of Representative Environmental Samples

### Testing of Soil and Sediment

**Investigation Question and DU Designation.** Testing of soil, sediment and other particulate matter for contaminants presents challenges similar to testing of crush ore for commodities. In the case of environmental contamination, the basic Investigation Question might be “Does the mean concentration of contaminant ‘X’ in the targeted area and volume of soil ‘Y’ exceed screening level or risk ‘Z’?”

Decision Units are designated for testing based on either the need to assess risk (“Exposure Area” DUs) or to better isolate areas of high contamination or estimate contaminant mass (“Source Area” DUs) and optimize remedial actions<sup>37,38</sup>. The size, shape and volume of DUs for a particular investigation will be dependent on the specific questions being asked. For example, a default DU area of a few hundred square meters (m<sup>2</sup>) to a depth of 15 cm might be adequate to assess risk posed by direct contact with contaminated soil in existing or planned residential areas. Larger DUs sizes might be appropriate for investigation of commercial or industrial sites. Designation of DUs for deeper, subsurface soil is usually based on the need to identify the main mass of contamination and optimize potential remedial actions. This is similar to the identification of an economically minable subsurface body of ore in the mining industry.

**Recommended Sampling Methods Sampling Methods.** The State of Hawai’i undertook detailed field studies of Theory of Sampling methodologies for testing of contaminated soil and sediment in 2004, the first state in the United States to do so. Guidance on the use of “Decision Unit” and “Multi Increment® Sample” (DU-MIS) investigation methods was first published in 2009 and updated in 2016. (Multi Increment® is a registered trademark of EnviroStat, Inc.) Additional updates were underway at the time this paper was published. Coordination was subsequently carried out with the Chinese Academy of Sciences, Nanjing Institute of Soil Science, for expansion and use of the guidance in China<sup>38</sup> (see also 41).

Error associated with distributional heterogeneity within a targeted DU is addressed through the collection and combination of a large number of small masses of particles throughout the targeted DU into a single sample. Each mass is referred to as an “increment.” For soils and other particulate matter, a field sample composed of at least 50 increments with a minimum mass of one to three kilograms and collected in a systematic, random manner is normally adequate to address distributional

heterogeneity and general sample collection error<sup>37,38</sup>. A greater number of sample increments and/or a larger sample mass might be required in cases where the contaminant is present as liberated “nuggets” within the particulate matter.

Error in the collection of subsamples at the laboratory is controlled in a similar manner as done in the field. The sample is allowed to air dry and then sieved to isolate the target, particle-size fraction. The sample might or might not be ground, depending on the nature of the Investigation Question being asked. Subsamples for testing are collected either through use of a sectoral splitter (preferred) or manually, following a similar, Multi Increment type collection method as used in the field. Subsamples must meet minimum mass requirements to address Fundamental Error and other error associated with subsample collection and testing, typically 30 grams.

A detailed review of sample collection and processing methods is provided in guidance published by the Hawai'i Department of Health<sup>37</sup> and the Chinese Academy of Sciences<sup>38</sup>. This includes methods for the collection of both surface and subsurface samples, as well as samples from stockpiles. Alternative approaches for the collection and testing of samples to be tested for volatile contaminants are also provided, as is guidance on the collection of replicate samples and step-by-step methods for a review of overall data quality.

### Testing of Subslab Vapors

**Investigation Question and DU Designation.** Contamination of indoor air is sometimes associated with a release of chlorinated solvents and petroleum fuels into soil and groundwater and subsequent upward diffusion and advective migration of vapors into overlying buildings, a process referred to as “vapor intrusion”<sup>27,31,21,25</sup>. A similar Investigation Question as applied to indoor air is applied to testing of subslab vapors: “Does the mean concentration of contaminant ‘X’ in vapors intruding the building during time period ‘Y’ exceed screening level or risk ‘Z’?”

The volume of subslab vapors intruding a building during the targeted time period is the DU. This volume can be approximated as the predicted vapor entry rate through gaps in the building slab times the time period of concern<sup>25</sup>. For example, a subslab vapor entry rate of 4.5 liters per minute is assumed for single-family home in cold climates where buildings are heated for much of the year based on the typical annual-average indoor-outdoor air pressure differential and the total area of cracks and gaps in floors. This implies a daily vapor entry rate of 6,480 liters.

Risk is assessed by comparison of the mean concentration of the contaminant in intruding vapors to a risk-based screening level or direct incorporation of the data into an indoor air impact model. Subslab vapor screening levels for vapor intrusion risk are calculated as the screening level for the contaminant in indoor air times the default indoor air:subslab vapor attenuation factor<sup>42</sup>. The attenuation factor reflects the volume of subslab vapors intruding through a building slab during the specified time period divided by the volume of indoor air circulating within the structure during the same time period and including fresh air brought in through the ventilation system (see above discussion). For example, an attenuation factor of 0.0032 is predicted for a single family home located in a cold climate zone  $(6,480/2,050,000)^{25}$ . In theory, a building specific attenuation factor can be calculated by dividing the concentration of a targeted contaminant in indoor air by the mean concentration of the contaminant in vapors intruding through the building slab. While simple in concept, this requires careful collection of a representative sample and knowledge of the specific location of intruding vapors is rarely known. The latter, in particular, is rarely known.

**Collection of Representative Samples.** A sample representative of a DU volume of vapors at a targeted point beneath the building slab is collected using a “Large Volume Purge (LVP)” sampling methodology<sup>43,44</sup>. Following this approach, a small-diameter (e.g., 5cm) subslab vapor sampling point is installed in the floor of a building based on the area anticipated to be most heavily contaminated or the area of the most sensitive receptors or, if neither is applicable, in the approximate center of the slab. The objective is to estimate the mean concentration of the targeted contaminant in vapors that could intrude through the point and impact indoor air over the targeted exposure period. Testing of vapors representative of vapor intrusion over an exposure period of several years is not feasible. Initial screening of potential risk can instead be carried out but collection of a sample representative of the volume of vapors predicted to intrude through the point over a period of several days. For example, the volume of vapors predicted to intrude a single family home in a cold climate over a period of five days would be approximately 32,000 liters<sup>25</sup>. This allows some control of distributional heterogeneity within the subslab vapor plume.

Under ideal circumstances, the entire DU volume of subslab vapors would be drawn from the sampling point and sent in a single container for testing. This again is practicable and a representative sample of the DU volume of air must instead be collected using an LVP method. Under this approach, a vacuum is used to draw the targeted volume of vapors from the sampling point. A continuous sample of the vapor stream is collected by connection of a Summa canister to the purge line. A six-liter canister is normally used. The vacuum is turned off when the target purge volume has been reached and the valve to the Summa canister closed. The canister is then submitted to the laboratory for analysis.

Data for the relatively small volume of vapor collected in the sample can be reasonably be assumed to be representative of the mean concentration of the targeted contaminant in the full volume of vapors purged from the point. As would be expected, field studies have documented an increasing mean concentration of the contaminant in vapors as the purge

volume increases<sup>45</sup>. This reflects the capture and inclusion of small pockets of elevated contamination of contaminants into the purge stream. This is similar to the observed increase in the mean concentration of a contaminant in soil with an increasing number of increments included in a sample<sup>15,16</sup>.

### Testing of Surface Water

**Investigation Question and DU Designation.** Testing of surface water is similar to testing of indoor air. In both cases the targeted media is contained within a fixed structure, in the first case a basin and in the second case a room or building. The water or air might or might not be flowing into and out of the containment. The contaminant of concern might be present as either individual, molecular-scale particles in a single-phase media, for example vaporized in air or dissolved in water, or as particulate matter in a dual-phase media. In the case of surface water, particulate matter might include suspended sediment or bacteria.

The volume of water held within or moving through a targeted area during the targeted time period is the DU. Designation of one or more DUs within a project area might be desirable based on the locations of specific aquatic habitats, suspect source areas, discharge points or other considerations. Risk is assessed by comparison of the mean concentration of the target compound for the DU volume of water as a whole to a screening level pertinent to the investigation question or by incorporating the data into a human health risk assessment (e.g., bacterial count or concentration of suspended sediments or dissolved-phase contaminants).

**Recommended Sampling Methods.** The above dilemma can be addressed through consideration of sampling methods more appropriate for infinite element media. Under this approach, a single sample of water is prepared by collection and combination of multiple "increments" of water from throughout the targeted DU. Water collected from each point is referred to as an "increment" and the combined increments referred to as a "Multi Increment" sample.

Isokinetic water sampling methods are used to collect depth-integrated samples from water moving more than 0.5 to 1.0 meters per second<sup>28,46</sup>. Under this approach the sampling device is lowered at a constant rate through the targeted depth interval. The device is designed to ensure that water enters the sampling container at a rate that directly corresponds to the velocity that the water is moving. This allows the sample collected to be representative of the volume of water moving through the point as a whole. Increments of water can be collected from multiple points perpendicular to the flow direction to prepare a Multi Increment sample. Concurrent, replicate samples can be collected from different points along the same transit line to evaluate the precision of the sample data. Samples can be collected at different time periods to assess variability in contaminant concentrations over time and in stream volumes of water.

Non-isokinetic samples can be used to collect Multi Increment samples in still water<sup>46</sup>. An example is the "Aloha Sampler™". (Aloha Sampler™ is a trademark of EnviroStat, Inc.) The sampler consists of a standard one-liter, high density polyethylene sample bottle with two to three holes drilled in the cap. The bottle is immersed horizontally at a consistent rate in a manner that allows water to enter the lower hole and air to escape from the top hole. The sampler lowers and raises the bottle to the target collection depth at multiple points throughout the entire DU. This allows collection of a sample representative of the DU volume of water as a whole.

These approaches allow collection of a representative sample of water in a time- and cost-efficient manner. Data collected are directly relatable to the Investigation Question asked. Independent, replicate samples are collected to test the precision of the sample data.

### Testing of Groundwater

**Investigation Question and DU Designation.** The collection of representative samples of groundwater presents challenges similar to the collection of subsurface soil vapor. Investigation questions applied to groundwater are similar to those applicable to subsurface vapors, for example: "Does the mean concentration of contaminant 'X' in groundwater passing through targeted area during time period 'Y' exceed screening level or risk 'Z'?" As applied to an individual well, the question might be: "Does the mean concentration of contaminant 'X' in groundwater extracted from the well during time period 'Y' exceed screening level or risk 'Z'?"

The concept of "Decision Units" is again not routinely discussed in published guidance. Decision Units for groundwater should be designated based on risk or optimization of remedial actions. For example, the standard exposure duration for assessment of noncancer health hazard and protection of young children is six years<sup>47</sup>. The standard exposure duration for assessment of cancer health risk in adults is 30 years. Under ideal circumstances, the capture zone that predicts the volume of groundwater to be produced by the well over the time period applicable to the COPC would be identified as the DU.

A purely risk-based approach to DU volume designation could be applied for periodic, snapshot monitoring of water quality. For example, an average drinking water ingestion rate of 0.78 liters per day is assumed for children ages 0 to 6 years and an average rate of 2.5 liters per day is assumed for adults. This equates to an annual volume of water consumed by a child over six years of 1,638 liters and over a 30 years by an adult of 23,538 liters. These could be considered to represent

Exposure Volume DUs.

Alternative DU volumes could also be designated for monitoring of remedial efforts (Remedial Monitoring DUs). The Investigation Question for a specific well can now be reworded to state: “Does the mean concentration of contaminant ‘X’ in the targeted DU volume of groundwater extracted from the well exceed screening level or risk ‘Z’?” The next step is to devise a method to collect a representative sample of this water.

**Collection of Representative Samples.** In the most ideal case, the entire six- to thirty-year production volume of water would be extracted from a production well and submitted to the laboratory for analysis as a single sample. This is of course not practicable. The water could alternatively be extracted, stored in a large tank and a single, Multi Increment sample collected and submitted for analysis. This again is unlikely to be practicable under most circumstances. A second alternative is to install multiple wells within the aquifer and prepare a single, Multi Increment sample by combining increments of water from each well into a single sample. Determination of the number of wells necessary to represent the DU volume of water would require a detailed field study. Replicate sets of wells would need to be installed and used to assess the precision of the data. This approach once more is unlikely to be practicable due to the cost required.

The focus of sample collection must therefore return to the collection of sample data from individual wells. Although not currently done, Large Volume Purge type sampling methods described above for the collection of subsurface vapor samples could be utilized to collect a sample representative of the targeted DU volume of water from a well<sup>46</sup>. For example, risk-based volumes of groundwater corresponding to the amount of water consumed over six years by children (e.g., 1,638 liters) could be periodically extracted from the well for testing. For nonvolatile contaminants, this might include storage of purged water in a large, holding tank and collection of a sample for testing. Replicate samples could be collected to test the precision of the sample collection method and the approach revised as needed. Excess water could be reinjected in the same area of the aquifer, allowed to infiltrate or otherwise treated or disposed of.

The collection of representative samples to be tested for volatile or otherwise unstable contaminants is more challenging. A continuous sample would presumably need to be continuously drawn from the purge train as the water is extracted from the well in the same manner as the collection of a sample during testing of subsurface vapors. Such methods are used for testing of flowing, surface water<sup>28</sup> but to the authors’ knowledge have not been adapted for testing of water flowing through a pipeline or sampling train. The precision of the data can be tested through the collection of replicate samples from the same sampling train.

## Summary and Discussion

Whether crushed ore, soil, air, water or other type of infinite element media, similar sampling concepts apply. The delay in the incorporation of Theory of Sampling concepts in the environmental industry for testing of subsurface vapors and water as well as soil and other particulate matter is related to several factors. This includes a lack of training of environment regulators; a reluctance to move away from traditionally accepted sampling methods; a lack of routine, third-party verification of sample data reliability; a lack of clear repercussions for erroneous data and the lack of guidance that presents a viable alternative. These problems are slowly beginning to be addressed as field-tested guidance becomes available and demand for more efficient and reliable investigation methods grows.

Environmental risk assessors sometimes mistakenly cling to discrete sample data for small volumes of air or other media in an attempt to assess “acute” health effects posed by the “maximum” concentration of a contaminant in the targeted media. Such an assessment would still require that a DU volume of the media specific to acute risk be designated, for example a few liters representing a single breath of air. This represents a finite element media sampling challenge, with each DU volume representing an individual “element” for which data are required. A large and likely unmanageable number of samples would then be required to predict the maximum concentration of the contaminant in any given DU volume of air within a specified level of confidence. For example, the collection of a minimum of 59 samples would be required to predict the maximum concentration of a contaminant of the contaminant in any given DU volume of air with a 95% confidence level (e.g., one-sided nonparametric tests)<sup>14</sup>. This is a different sampling problem and only occasionally a part of environmental investigations<sup>48</sup>.

Caution is still called for, however. A recent guidance document<sup>49</sup> for what is referred to as “Incremental Sampling Methodology (ISM)” provides a reasonable overview of discrete sample data error and the incorporation of Theory of Sampling concepts in the collection, processing and testing of soil and sediment samples. As critiqued by the Hawaii Department of Health<sup>50</sup>, the document then erroneously regresses to require the use of statistical tests applicable to finite element media to assess risk and calculation a 95% Upper Confidence Level (UCL) for final decision making. This necessarily requires the expensive and unnecessary collection of replicate samples in all DUs. As an alternative, the guidance implies that a 95% UCL based on as few as ten discrete samples can instead be used for decision making, ignoring the unreliability of discrete sample data discussed in earlier sections of the document. Such compromises and mistakes do not properly address Theory of Sampling and must be rigorously opposed.

## References

1. F.F. Pitard, *Pierre Gy's Sampling Theory and Sampling Practice*. New York: CRC Press (1993).
2. F.F. Pitard, "Sampling correctness – A comprehensive guideline", *Proceedings of Sampling and Blending Conference (WCSB2)*. Sunshine Coast, Queensland, Australia (2005).
3. F.F. Pitard, "Theoretical, practical and economic difficulties in sampling for trace constituents", *Proceedings of the Fourth World Conference on Sampling and Blending (WCSB4)*. The Southern African Institute of Mining and Metallurgy, Cape Town (2009).
4. F.F. Pitard, *Theory of Sampling and Sampling Practice*. Chapman and Hall/CRC, Boca Raton, Florida, ISBN 9781138476486 (2019).
5. C.A. Ramsey and A.D. Hewitt, "A methodology for assessing sample representativeness", *Environ Forensics* **6**, 71–75 (2005).
6. R.C.A. Minnitt, P.M. Rice and C. Spangenberg, "Part 1: Understanding the components of the fundamental sampling error: A key to good sampling practice", *J. South. Afr. Inst. Min. Metall.* **107**, 505–511 (2007).
7. USEPA, *Verification of PCB Spill Cleanup by Sampling and Analysis*. United States Environmental Protection Agency, Washington, DC, EPA-560/5-85-02, (1985).
8. USEPA, *Field Manual for Grid Sampling of PCB Spill Sites to Verify Cleanups*. United States Environmental Protection Agency, Office of Toxic Substances, Washington, DC, EPA-560/5-86-017 (1986).
9. USEPA, *Low Flow (Minimal Drawdown) Ground-Water Sampling Procedures*. United States Environmental Protection Agency, Office of Research and Development, EPA/540/S-95/504 (1996).
10. USEPA, *Groundwater Sampling*. United States Environmental Protection Agency, Science and Ecosystem Support Division, SEDPROC-301-R4 (2017).
11. USEPA, *RCRA Orientation Manual*. Office of Resource Conservation and Recovery, United States Environmental Protection Agency (2014).
12. USEPA, *Risk Assessment Guidance for Superfund. Volume I, Human Health Evaluation Manual (Part A)*. United States Environmental Protection Agency, Office of Emergency and Remedial Response, EPA/540/1-89/092 (1989a).
13. USEPA, *Risk Assessment Guidance for Superfund. Volume II, Environmental Evaluation Manual*. United States Environmental Protection Agency, Office of Emergency and Remedial Response, EPA/540/1-89/001 (1989b).
14. USEPA, *Methods for Evaluating the Attainment of Cleanup Standards, Volume 1: Soils and Solid Media*. United States Environmental Protection Agency, Office of Policy, Planning, and Evaluation, Washington, DC, EPA/230/02-89/042 (1989c).
15. R. Brewer, J. Peard and M. Heskett, "A critical review of discrete soil sample reliability: Part 1 – Field study results", *Soil and Sediment Contamination* **26**, 1 (2017a). <http://dx.doi.org/10.1080/15320383.2017.1244171>
16. R. Brewer, J. Peard and M. Heskett, "A critical review of discrete soil sample reliability: Part 2 – Implications", *Soil and Sediment Contamination* **26**, 1 (2017b). <http://dx.doi.org/10.1080/15320383.2017.1244172>
17. USEPA, *Preparation of Soil Sampling Protocols: Sampling Techniques and Strategies*. United States Environmental Protection Agency, Office of Research and Development, Washington, DC, EPA/600/R-92/128 (1992).
18. USEPA, *A Rationale for the Assessment of Errors in the Sampling of Soil*. United States Environmental Protection Agency, Environmental Monitoring Systems Laboratory, Washington, DC, EPA/600/4-90/013 (1990).
19. USEPA, *Guidance on Surface Soil Cleanup at Hazardous Waste Sites*. United States Environmental Protection Agency, Office of Emergency and Remedial Response, Washington, DC (EPA 9355.0-91 (2005).
20. USEPA, *ProUCL Version 5.0.00, User Guide*. United States Environmental Protection Agency, Office of Research and Development, Washington, DC, EPA/600/R-07/041 (2013).
21. ITRC, *Vapor Intrusion Pathway: A Practical Guideline*. Interstate Technology Regulatory Council (2007).
22. CAEPA, *Guidance for the Evaluation and Mitigation of Subsurface Vapor Intrusion to Indoor Air*. California Environmental Protection Agency, Department of Toxic Substances Control (2011).
23. CAEPA, *Advisory – Active Soil Gas Investigation*. California Environmental Protection Agency, Department of Toxic Substances Control (2015).
24. T. E. McHugh, T.N. Nickels and S. Brock, "Evaluation of spatial and temporal variability in VOC concentrations at vapor intrusion investigation sites", *Proceeding of Air & Waste Management Association's Vapor Intrusion: Learning from the Challenges*, pp 129-142 (2007).
25. R. Brewer, J. Nagashima, M. Rigby, M. Schmidt and H. O'Neill, "Estimation of generic subsurface attenuation factors for vapor intrusion investigations", *Groundwater Remediation and Monitoring* **34**, 79–92 (2014). doi: 10.1111/gwrmr.12086
26. H. Luo, P. Dahlen, P.C. Johnson, T. Peargin and T. Creamer, "Spatial variability of soil-gas concentrations near and beneath a building overlying shallow petroleum hydrocarbon impacted soils", *Groundwater Monitoring & Remediation* **29** (1), 81–91 (2009).

27. USEPA, *EPA's Vapor Intrusion Database: Evaluation and Characterization of Attenuation Factors for Chlorinated Volatile Organic Compounds and Residential Buildings*. United States Environmental Protection Agency, Office of Solid Waste and Emergency Response, EPA 530-R-10-002 (2012a).
28. USGS, *National Field Manual for the Collection of Water-Quality Data, Chapter A4 – Collection of Water Samples*. United States Geological Survey (2006).
29. USEPA, *Correct Sampling Using the Theories of Pierre Gy*. United States Environmental Protection Agency, National Exposure Research Laboratory, Environmental Sciences Division, Technology Support Center, Washington, DC, Fact Sheet 197CMB98.FS-14 (1999).
30. USEPA, *Guidance for Obtaining Representative Laboratory Analytical Subsamples from Particulate Laboratory Samples*. United States Environmental Protection Agency, Office of Research and Development, Washington, DC, EPA/600/R-03/027 (2003).
31. USEPA, *User's Guide for Evaluating Subsurface Vapor Intrusion into Buildings*. United States Environmental Protection Agency, Office of Emergency and Remedial Response (2004).
32. ASHRAE, *Ventilation for Acceptable Indoor Air Quality*. American Society of Heating, Refrigerating and Air-Conditioning Engineers, Standard 62.1. Atlanta, GA (2013).
33. B. Hartman, "How to collect reliable soil-gas data for risk-based applications, Part 1: Active soil-gas method", *New England Interstate Water Pollution Control Commission, LUSTLine Bulletin* **42** (2002).
34. Air Toxics, *Guide to Air Sampling and Analysis, Canisters and Tedlar Bags*. Air Toxics, Ltd. (2012).
35. Air Toxics, *Sorbent and Solution Sampling Guide*. Air Toxics, Ltd. (2012).
36. USEPA, *Vertical Distribution of VOCs in Soils from Groundwater to the Surface/Subslab*. United States Environmental Protection Agency, Office of Research and Development, EPA/600/R-09/073 (2009).
37. HDOH, *Technical Guidance Manual (Sections 3-5, Soil and Sediment)*. Hawai'i Department of Health, Office of Hazard Evaluation and Emergency Response (2021).
38. CAS, *Standard for the Use of Decision Unit and Multi Increment Sample Investigation Methods to Assess Soil Quality*. Chinese Academy of Sciences, Nanjing Institute of Soil Science (in final review, 2022).
39. AAFCO, *GOODSamples: Guidance on Obtaining Defensible Samples*. Association of American Feed Control Officials, Champaign, Illinois. (2015).
40. AAFCO, *Good Test Portions: Guidance on Obtaining Defensible Test Portions*. Association of American Feed Control Officials, Champaign, Illinois (2018).
41. R. Brewer, J. Song, J. and C. Ramsey, "Advanced sampling methods to expedite the reliable characterization, remediation and redevelopment of contaminated industrial lands in China", *Proceedings of the 9th World Conference on Sampling and Blending (WCSB9)*. Beijing, China, pp. 292-307 (2019).
42. HDOH, *Evaluation of Environmental Hazards at Sites with Contaminated Soil and Groundwater (Hawaii Edition)*. Hawai'i Department of Health, Office of Hazard Evaluation and Emergency Response (2017a).
43. T.A. McAlary, P.J. Nicholson, L.K. Yik, D.M. Bertrand, and G. Thrupp. "High purge volume sampling - a new paradigm for subslab soil gas monitoring", *Ground Water Monitoring and Remediation* **30** (2), 73–85. (2010).
44. HDOH, *Technical Guidance Manual (Section 7: Indoor and Soil Vapor)*. Hawai'i Department of Health, Office of Hazard Evaluation and Emergency Response (2017b).
45. HDOH, *Field Study of High-Density Passive Sampler and Large-Volume Purge Methods to Characterize Subslab Vapor Plumes*. Hawaii Department of Health, Office of Hazard Evaluation and Emergency Response (2017c).
46. HDOH, *Technical Guidance Manual (Section 6: Surface Water and Groundwater)*. Hawai'i Department of Health, Office of Hazard Evaluation and Emergency Response (2021).
47. USEPA, *Screening Levels for Chemical Contaminants*. United States Environmental Protection Agency, Superfund Program (2021).
48. C. Ramsey and K. H. Esbensen, "Inferential statistical sampling of hyper-heterogeneous lots with hidden structure: the importance of proper Decision Unit definition", *Spectroscopy Europe* **34** (2) (2022).
49. ITRC, *Incremental Sampling Methodology*. Interstate Technology and Regulatory Council (2020).
50. HDOH, *Critique and Use of ITRC Incremental Sampling Methodology Guidance Document in Hawai'i*. Hawai'i Department of Health, Office of Hazard Evaluation and Emergency Response (November 23, 2020).

<b>Mining Industry</b>	<b>Environmental Industry</b>
1. Geologic Map	1. Site Conceptual Site Model
2. Preliminary Ore Body Identification	2. Preliminary Source Area Identification
3. Mining and Crushing	3. (not applicable; already particulates)
4. Sample Collection (TOS)	4. Sample Collection (discrete)
5. Sample Processing (TOS)	5. Sample Processing (minimal/none)
6. Subsample Collection (TOS)	6. Subsampling Collection (discrete)
7. Data Quality Review <ul style="list-style-type: none"> <li>• Sample collection method;</li> <li>• Field replicate precision;</li> <li>• Laboratory replicate precision;</li> <li>• Analytical precision;</li> <li>• Unadjusted data used for decision making.</li> </ul>	7. Data Quality Review <ul style="list-style-type: none"> <li>• Minimal to no testing of field sample or lab subsample reproducibility;</li> <li>• Validation of laboratory analytical method only;</li> <li>• 95% UCL of mean of discrete samples used for decision making.</li> </ul>
8. Economic Feasibility Assessment	8. Environmental Risk Assessment
9. Commodity Extraction and Marketing	9. Contaminant Destruction or Isolation

**Figure 1. Comparison of mining industry and environmental industry sampling methodologies.**

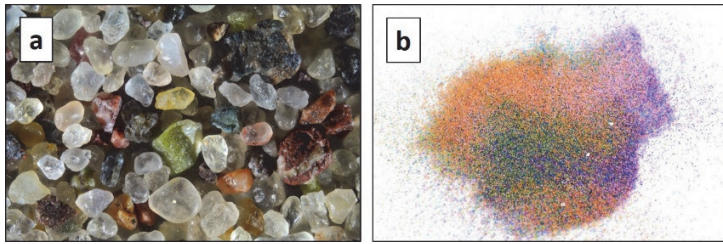

**Figure 2. Example of compositional heterogeneity between individual particles (a) and distributional heterogeneity of particle types within a targeted volume of material (b).**





## Representative Sampling for condition monitoring of in-service wind turbine bearings: challenges and solutions over 10 years

H. Møller<sup>a</sup> and K.H. Esbensen<sup>b</sup>

<sup>a</sup>Sr. Specialist, COWI A/S, Visionvej 53, Aalborg, DK [hsmo@cowi.com](mailto:hsmo@cowi.com)

<sup>b</sup>Owner, KHE Consulting, Copenhagen, DK [khe.consult@gmail.com](mailto:khe.consult@gmail.com)

**Development of cost-effective and accurate methods are crucial for operational condition monitoring of wind turbine blade bearings. Based on the Theory of Sampling (TOS), a novel method for acquiring representative samples of lubricating grease from in-service wind turbine blade bearings has been developed over the last 10 years, in some respects similar to ‘on-line’ PAT approaches used for continuous process sampling. The new method is compared and evaluated to a comprehensive, fully TOS-compliant reference sampling performed on dismantled bearings, which is a complete analogue to ‘stopped belt’ reference sampling. Three case studies are reported with which to illustrate the merits of the new wind turbine bearing condition monitoring method, which is needed in the rapidly developing renewable CO<sub>2</sub>-free energy supply chain. Seen in the context of the currently much accelerated need for a massive green transition, the market prospects for this wind turbine process sampling approach can hardly be overestimated.**

### Introduction

The development of wind turbine technology is an incredible and fascinating story. In the 1980s, the first onshore turbines of 20 - 50 kW were erected, but at that time very few had the imagination to see what this would lead to. The first larger offshore wind farm was probably Horns Rev 1 off Denmark's west coast with an installed capacity of 160 MW (80 x 2 MW), commissioned in 2002. At the end of 2021, globally 54,000 MW of offshore capacity were installed, and this capacity will certainly be 10 times larger by 2030. This rapid growth has taken place because technology and advanced materials have made electricity produced by offshore turbines so inexpensive that today, in many parts of the world, it can easily outcompete electricity produced from fossil fuels.

Therefore, offshore wind will be a decisive factor in the transition to a hydrocarbon-free society (as shown in the video accompanying this presentation). In just a few years, the first ‘energy islands’ will be built, surrounded by very large numbers of wind turbines. These islands will each have an installed capacity of 10 to 30 GW! Presumably, a significant part of this electrical energy will be used on the islands themselves to produce hydrogen, which will be piped ashore much like natural gas is today.

As offshore wind becomes a crucial element in the supply of renewable CO<sub>2</sub>-free energy, the need to ensure continuing high availability increases. This involves many aspects; this presentation focuses on how the condition of the grease lubricated components in offshore turbines, primarily blade and main *bearings*, can be monitored by analysing representative samples of grease from the bearings. A previous project,<sup>1-3</sup> investigated in technical detail how to sample grease from in-service blade bearings.

Below, the main points from this study are reviewed, after which three case studies are presented that document the suitability of grease analysis for determining the contemporary *condition* of blade bearings.

### Main components of an offshore wind turbine

An offshore wind turbine consists of the following main components: rotor blade assembly (hub and the three blades), nacelle and tower plus a transition piece (Figure 1). The rotor blade assembly consists of three blades with a bearing at the root of each blade. Blade bearings serve two purposes: i) connecting the blade, which is the unit that collects energy from the wind to the nacelle, and ii) to enable the blade to rotate around its longitudinal axis i.e., to change its pitch. Blade bearings are therefore also often termed ‘pitch bearings’ (Figure 2).

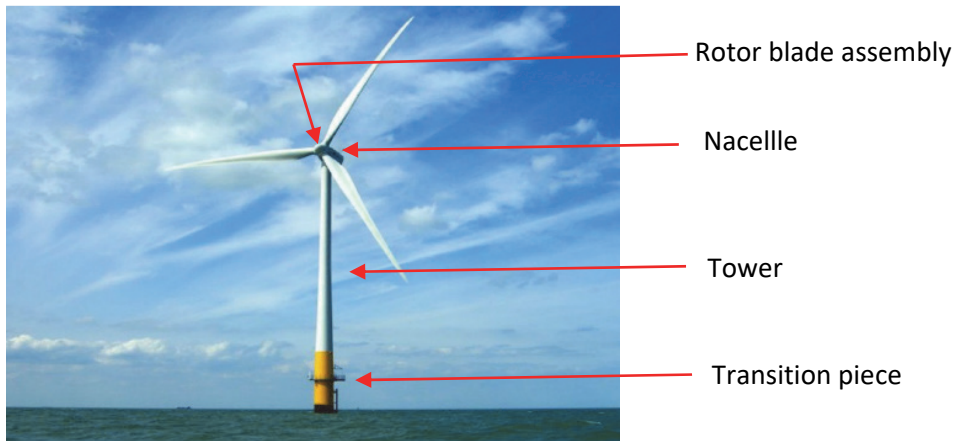

Figure 1. Component of a windmill.

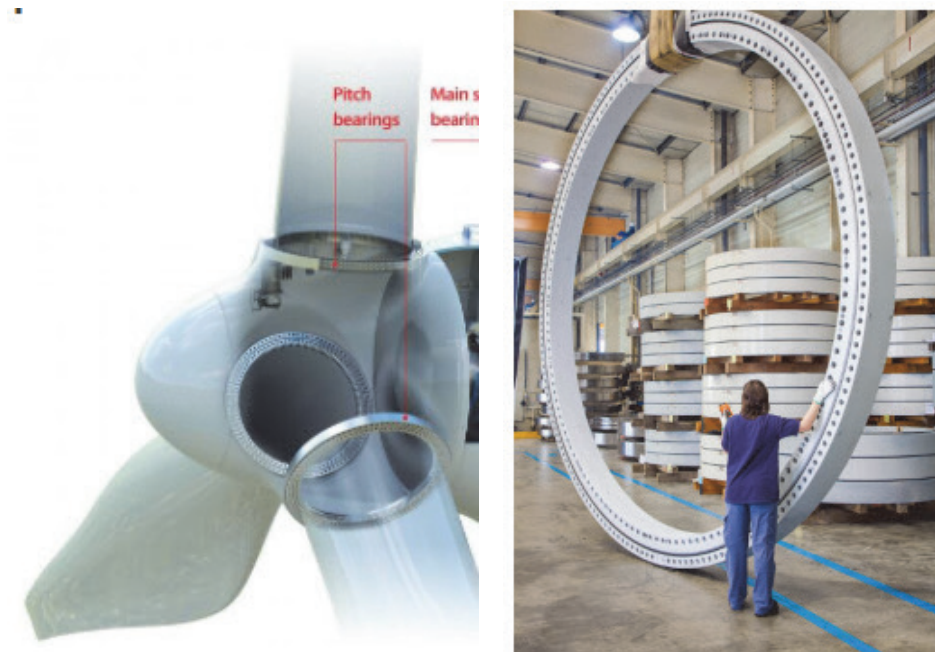
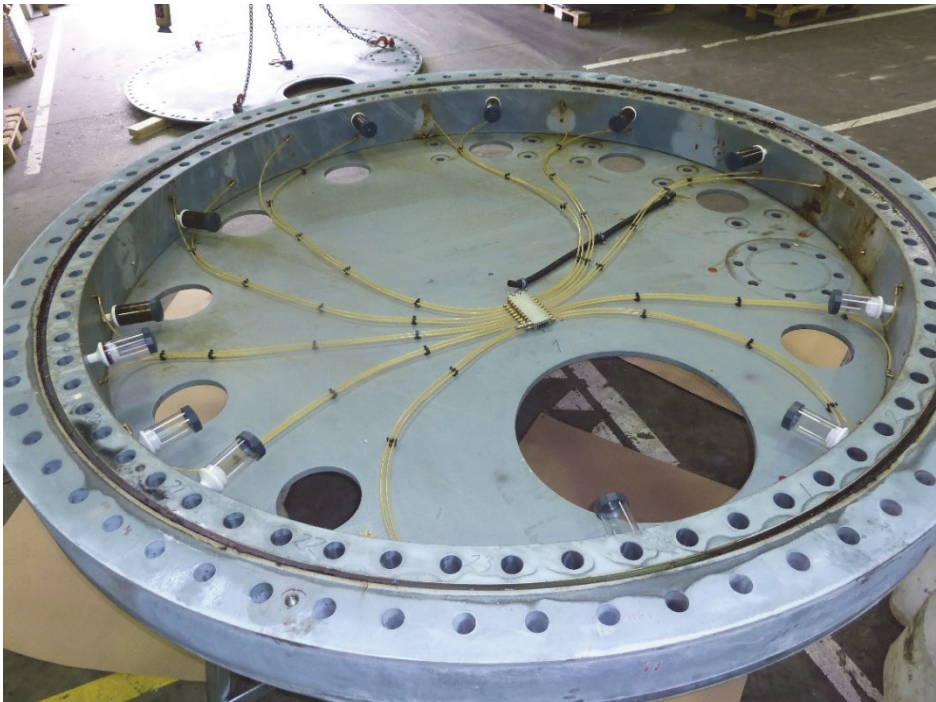

Figure 2. Rotor blade assembly (left) and complete blade bearing (right).

### Representative sampling of grease from blade bearings

When a blade bearing has been assembled, it is no longer possible to access its active part, i.e., the space between the outer and inner races to take grease sample(s). However, in operation there is a continuous supply of new grease to the bearing, and the excess grease is pressed out and collected in containers located on either the outer or inner race of the blade bearing. These containers are accessible for taking in-service grease samples (Figure 3).



**Figure 3. Blade bearing in a 3.6 MW turbine with grease collecting devices ("Grease cups") fitted to the inner ring. The Grease cups are accessible for sampling of in-service grease samples used for condition monitoring.**

In a previous study<sup>3</sup>, a full 3D-heterogeneity characterization of the grease in the active zone of blade bearings has been developed and described full detail. A summary will suffice for the present purpose.

With a bearing dismantled for inspection, it is possible to conduct sampling of the active raceway in a representative fashion according to TOS, as illustrated in

. Dismantling allows sampling and full characterization of the variation and properties of the grease *along* the full 360-degree active zone of the bearing in the space between the raceways.

This sampling scheme, here termed the 3-D heterogeneity characterization, forms the reference against which the in-service grease sampling from grease cups is to be compared and evaluated. As this characterization is fit-for-purpose *representative*<sup>3</sup>, it is the best available estimate of the properties of the active raceway lot, be this in the form of an *average* over the full circumference of the bearing ring, or as a *mapping* of the peripheral compositional variation in the active zone between the raceways.



**Figure 4. Representative reference grease sampling (TOS) from a dismantled 3.6 MW blade bearing. Increments from every second ball support hole were taken for the 3-D heterogeneity characterization of the grease in the complete 360 degree active zone in the space between the raceways, furthering a reference analogue to "stopped belt" sampling.**

The analytes used in this reference characterization were i) content of ferro-magnetic iron, ii) water content, and iii) particle size distribution of wear debris. In total 175 grease samples were included in this comprehensive study and the results led to the conclusion that 'grease cup' sampling is a satisfactory *proxy* for representative sampling of an active raceway. Full documentation can be found here<sup>3</sup>.

### Condition monitoring of blade bearings

Blade bearings have an atypical mode of operation, as they do not normally rotate when the turbine is in operation. This mode means that vibration analysis is not an option. Sampling and analysis of grease from blade bearings is today the only useful method for obtaining reliable data for assessing the operating condition of bearings.

The content of wear particles, size distribution and morphology are the most important parameters for assessing the condition of any grease lubricated bearing. COWI has developed dedicated analysis approaches which have proven to be suitable for mapping the condition of blade bearings over time. In our experience only wear particles larger than approximately 100  $\mu\text{m}$  are relevant for a condition check of blade bearings. COWI's analysis program for used blade bearing grease therefore includes the following parameters:

- Content of ferro-magnetic wear particles, FdM-Fe (ASTM D8120)
- Size distribution of ferro-magnetic wear particles larger than 100  $\mu\text{m}$
- Microscopy of selected particles to determine type of wearing
- Water content (Karl-Fischer titration)

As a rule, samples of grease are taken from two randomly selected collection containers distributed along the complete inner or outer raceways a given bearing, see Figure 3.

In the following, three case stories are presented with typical examples of how analysis of grease can accurately determine the physical condition of bearings.

#### Case Study 1: Blade bearings, 2 MW Turbine

Grease samples from three blade bearings, labelled A, B, and C, were examined for content of ferromagnetic wear debris. The results are shown in Figure 5.

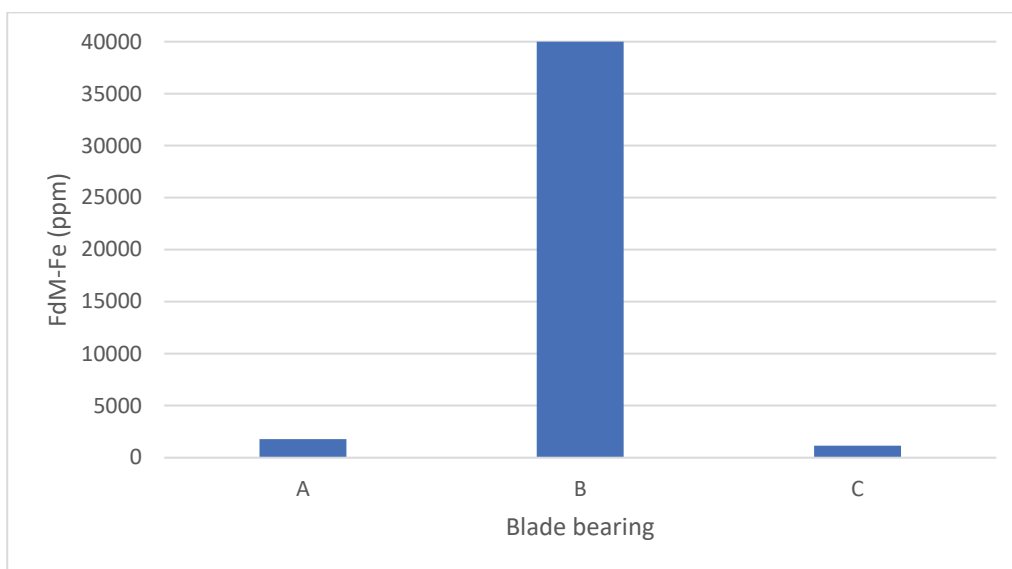

**Figure 5. Content of ferro-magnetic wear particles in the three blade bearings from a 2 MW turbine.**

Blade bearing B had a very high content of ferro-magnetic wear particles, significantly higher than the other two bearings. Ferro-magnetic wear particles were collected on a membrane filter, Figure 6. The number and size distribution of ferro-magnetic wear particles larger than 100  $\mu\text{m}$  are shown in Figure 7. Figure 8 shows examples of very large wear particles in grease from blade bearing B.

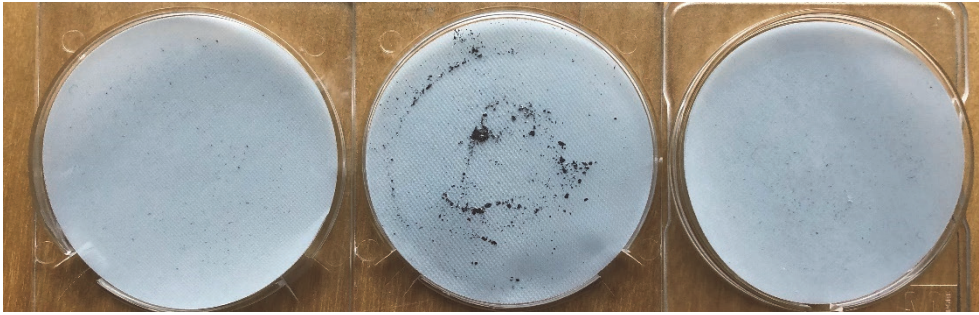

Figure 6. Membrane patches with ferro-magnetic wear debris - from left to right blade A, B and C.

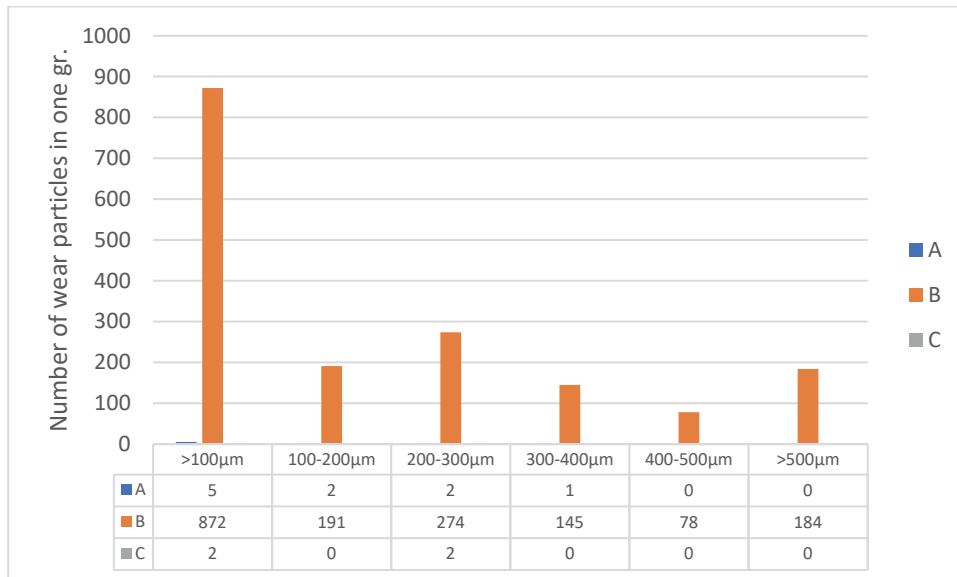

Figure 7. Number of wear particles per gram of grease and their size distribution.

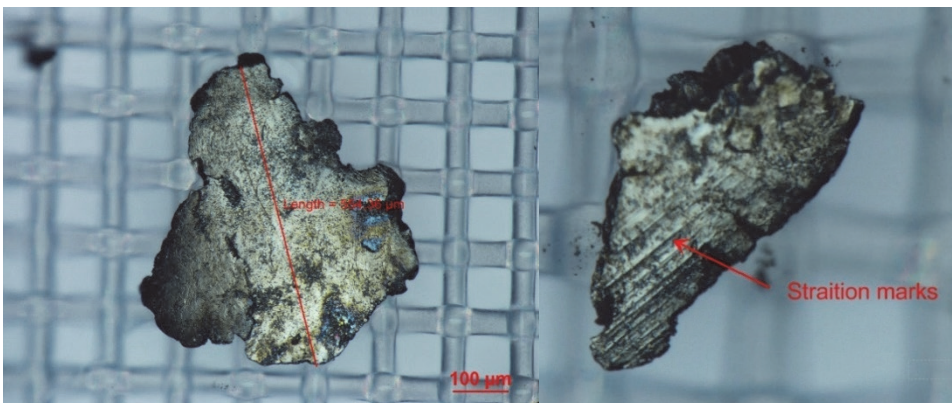

Figure 8. Large wear particles observed in grease from blade bearing B. Note 100 µm scale bar.

These results unequivocally showed blade bearing B to be so damaged that it had to be replaced. This assessment was confirmed when the bearing was subsequently opened for a closer inspection, Figure 9. It was clear that this bearing had reached the end of its safe usage.



**Figure 9. Appearance of blade bearing B, a deep groove ball bearing. Note the heavy peeling on the raceway and that several of the balls were cracked.**

**Case Story 2: Blade Bearings, 4 MW turbine after 10 years of operation**

The same analysis program for ferro-magnetic wear debris was used as in case 1, with results shown in Figures 10 through 12. There is a remarkably large difference between the operating conditions of the three blade bearings in this 4 MW turbine after 10 years of operation. Blade bearing A shows no signs of failure while bearing B must be characterized as severely damaged. The bearing was subsequently replaced. Bearing C also has an elevated content of ferro-magnetic wear particles, but it was estimated that this bearing could stay in operation for a few more years.

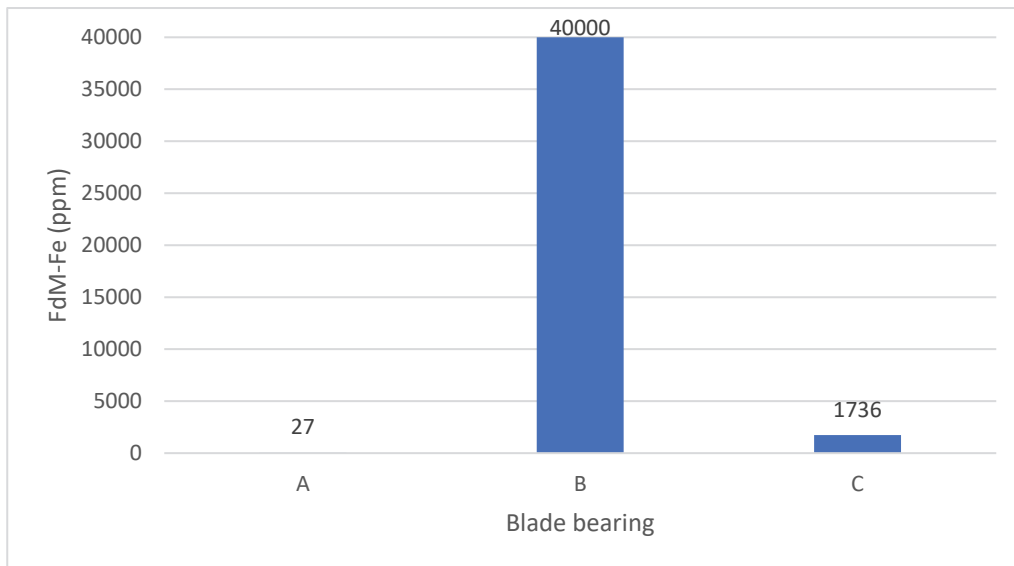

**Figure 10. Content of ferro-magnetic wear particles in the blade bearings from the 4MW turbine.**

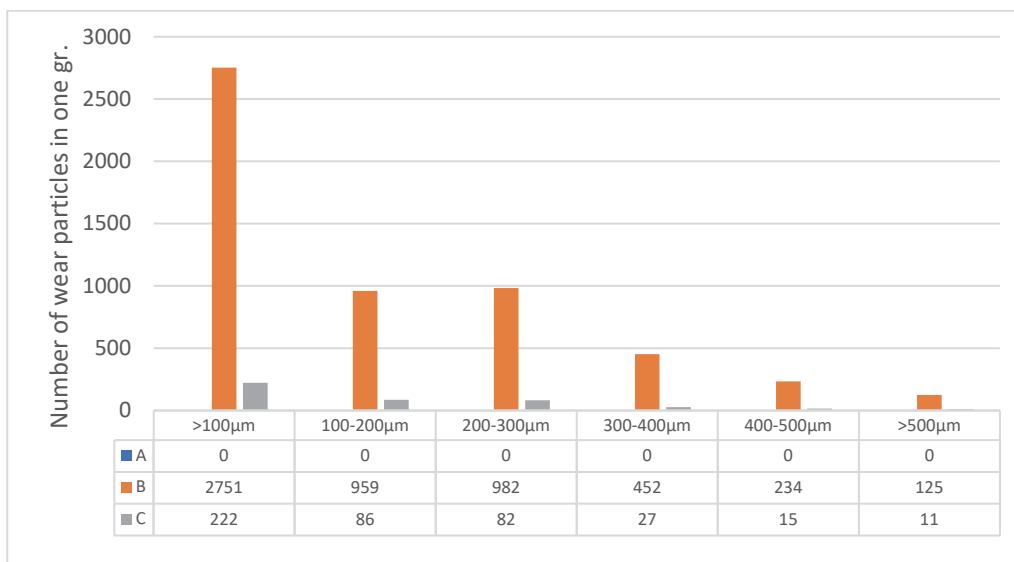

**Figure 11. Number of wear particles per gram of grease and their size distribution.**

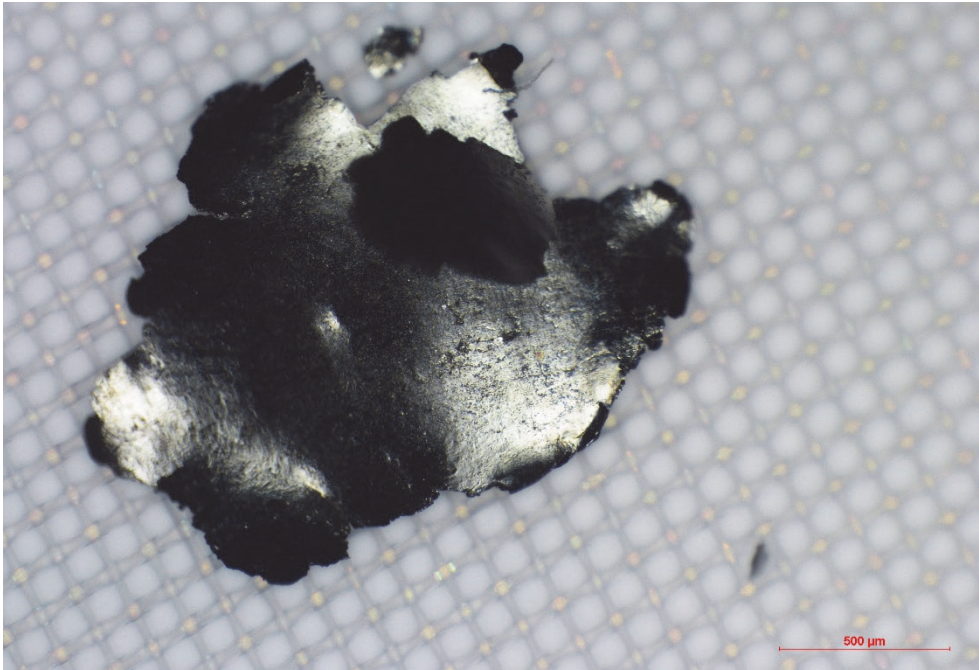

Figure 12. Very large wear particle observed in grease from blade bearing B. Note 500 μm scale bar.

### Case Story 3: Blade bearings, offshore wind farm. Turbine size 4-6 MW

Over the last five years, COWI has analysed a large number of grease samples from blade bearings in offshore turbines, which has led to some surprising and interesting observations. Based on this monitoring, it can be stated that well-functioning blade bearings show a low, constant content of ferro-magnetic wear particles. One might have expected that the number of dislodged particles would tend to increase as wearing continues as the bearing ages, but this is not the case. Figure 13 shows the FdM-Fe trend data for blade bearings without problems compared with a blade bearing (blade bearing C, turbine C01) that clearly has a high and increasing content of ferro-magnetic wear particles.

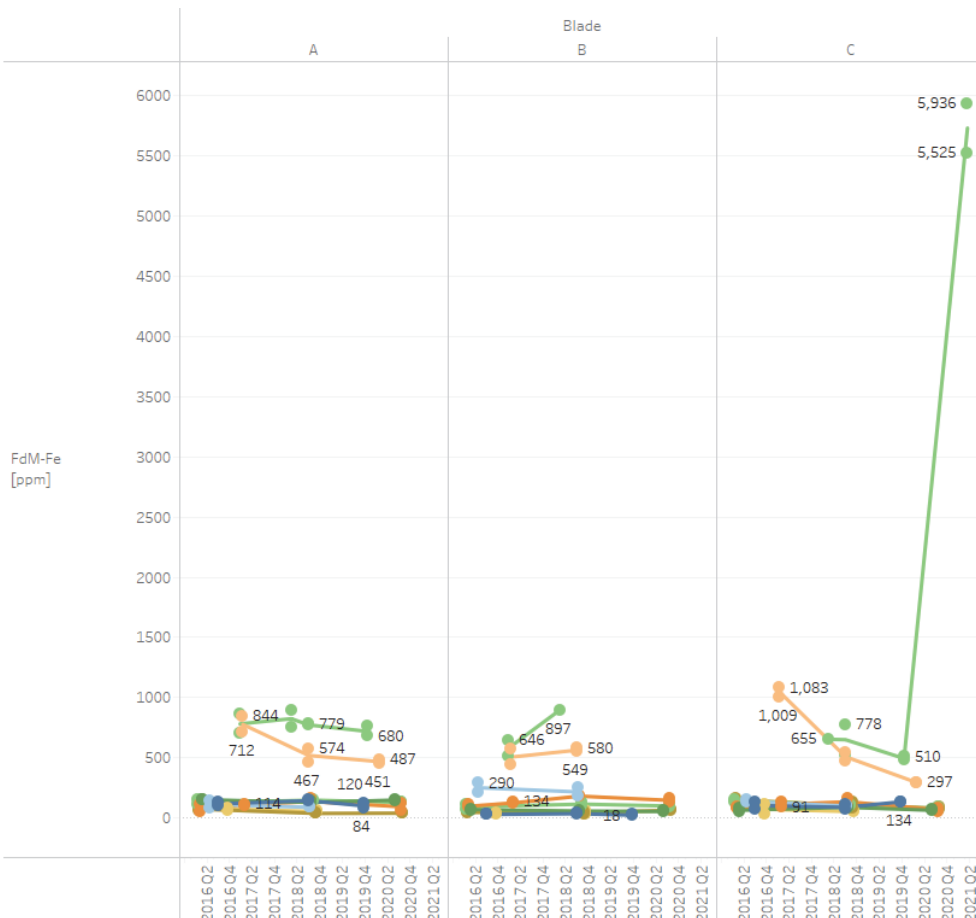
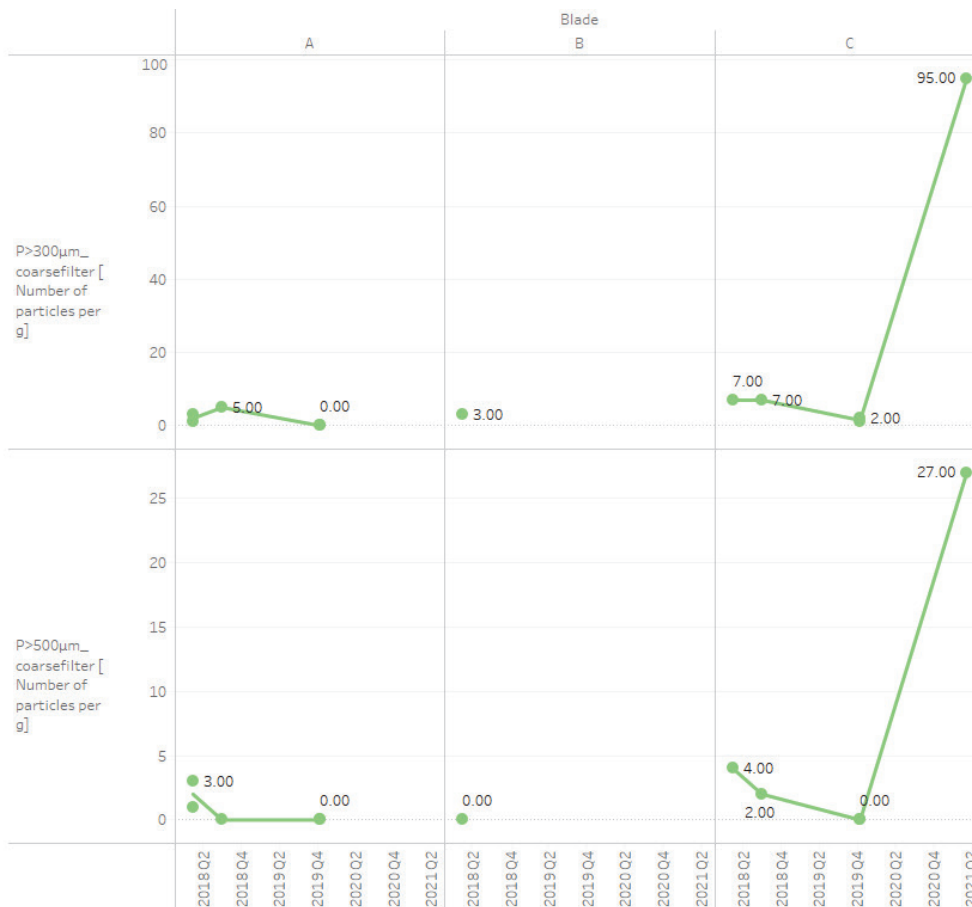

Figure 13. FdM-Fe trend data for blade bearings without sign of faults (constant level of FdM-Fe) and one bearing (C, turbine C1, green line) with increasing content of ferro-magnetic wear debris clearly predicting premature failure of this bearing.



Figure 14 shows the development in the defective blade bearing C. The graph shows the content of ferro-magnetic wear particles per gram of grease. The upper graph indicates the content of particles with a size in the range 300–400  $\mu\text{m}$ , while the lower graph shows the content of particles larger than 500  $\mu\text{m}$ . The presence of such very large wear particles indicates significant destruction of the bearing race which will lead to a significantly reduced service life for the bearing.



**Figure 14.1** Trend data for blade bearings without sign of faults (very low and constant amount of large ferro-magnetic wear particles) and the bearing C with significantly increasing content of ferro-magnetic wear debris.

## Discussion

Offshore wind turbines in many countries of the world will become part of the backbone of the necessary transition to a CO<sub>2</sub>-free renewable energy supply basis. Offshore wind turbines are extremely capital-intensive investments, for which reason cost-effective methods for operating and monitoring these assets are highly desirable. To solve this task, many different analytical tools (physical, chemical, artificial intelligence, AI) are used today to process today's readily available on-line data remotely onshore, with obvious needs for automation.

However, there are still main components, for which no documented method for continuous operational monitoring exists – yet, such as blade bearings. To monitor the crucial blade bearing component, the authors consider regular in-service sampling and analysis of bearing grease to be the most suitable method available today. The new in-service condition monitoring approach has many similarities with 'on-line' Process Analytical Technologies (PAT) approaches, used for TOS-compliant process sampling.

## Conclusions

Using the Theory of Sampling (TOS), it has been possible to develop a method for acquiring representative samples of grease from blade bearings in a wind turbine, which is a crucial prerequisite for development of an operational condition monitoring approach of in-service blade bearings.

With leading competence in tribology (the science of wear and friction), over the last 10 years, COWI has developed analytical methods targeting operational monitoring of grease lubricated bearings in wind turbines. These methods have been successfully implemented in several offshore wind farms - primarily in Northern Europe - but the full market roll-out has just begun.

## References

1. Møller, H., Giselsson, T.M., Wurzbach, R. & Esbensen, K.H. (2012). Analysis of Grease in Wind Turbine bearings – a tool for condition monitoring. LUBMAT conference 2012. Barcelona. Proceedings.
2. Møller, H., Wurzbach, R, Esbensen, K.H., Larsen, u, Giselsson, T.M., Ukonsaari, J. (2014). Analysis of Grease in Wind Turbine bearings – a tool for condition monitoring, Part 2. LUBMAT conference 2014, Manchester. Proceedings.
3. Møller, H.S., Esbensen, K.H., Wurzbach, R. (2016). Grease sampling and analysis for in service Condition Monitoring (CM) of wind turbine blade bearings, LUBMAT conference 2016. Bilbao. Proceedings



## Experimental determination of the constitutional heterogeneity for sampling of Waste Printed Circuit Boards

S. Brochot<sup>a</sup>, Ph. Wavrer<sup>b</sup>, A. Hubau<sup>c</sup> and S. Touzé<sup>d</sup>

<sup>a</sup>CASPEO – 3 avenue Claude Guillemin BP36009 – 45060 Orléans - France. E-mail: s.brochot@caspeo.net

<sup>b</sup>CASPEO – 3 avenue Claude Guillemin BP36009 – 45060 Orléans - France. E-mail: p.wavrer@caspeo.net

<sup>c</sup>BRGM – 3 avenue Claude Guillemin BP36009 – 45060 Orléans - France. E-mail: a.hubau@brgm.fr

<sup>d</sup>BRGM – 3 avenue Claude Guillemin BP36009 – 45060 Orléans - France. E-mail: s.touze@brgm.fr

**Sampling and analysis of Waste Printed Circuit Boards (WPCBs) become of high importance because of the strong increase in the annual production of such waste and equally because of the value and criticality of the contained metals. As a result of human production, we could expect to know exactly the heterogeneity of constitution of WPCBs, but this is still far away from reality, and there is no effective data available due to lack of documentation and rapid obsolescence of such equipment, the lot composition itself being highly variable over time.**

**In the frame of a project focused on the WPCBs recycling, BRGM has conducted a set of experiments with the double objective to define an appropriate sampling and analytical procedure and to estimate the variability of such procedures for the determination of the content of six metals. Different operating conditions have been tested: three grinding sizes and three sample masses. For each case, the procedure has been repeated several times sufficient to consider statistics. A theoretical study has then been performed to deconvolute sampling and analytical errors from these statistics. The paper presents this approach and the techniques used to go back to the heterogeneity of such material. The analytical error is calculated for the different protocols allowing the experimental identification of the last stage total sampling error. Discussion is made about the possibility to estimate the intrinsic heterogeneity parameter at the different stages of the sampling procedure.**

### Introduction

Due to the increasing consumption of electronic devices such as computers, smartphones, screens, toys, but also all embedded processors and Internet of Things (IoT) devices, the Waste Printed Circuit Boards (WPCB) will also continue to increase rapidly, without considering the huge stock of such waste lying dormant in households, offices, and industrial stock rooms. As a non-negligible secondary source of critical and precious metals, the WPCB are the focus of increasing interest for recycling and recovery. But this resource is eminently variable in space, depending on the concentration of specific kinds of devices during collection, but also with time due to the rapid evolution of the technologies and the resulting short lifetime of such devices. Continuous monitoring of this resource and estimation of its potential value through recovery processing necessitate to regularly analyse it by taking and processing samples.

But the WPCB are very heterogenous objects made of similar electronic components but in a wide range of proportions (Figure 1). The composition of these components in terms of metals is also very variable. Consequently, there is a large intrinsic heterogeneity whatever the stage in the sampling process: entire PCBs after dismantlement, pieces of PCB after shedding, individual components, fractions of components after grinding, liberated fractions of metals from components and printed boards after pulverisation. In addition, the metals as analytes are present in different forms: as pure metal or alloy in individual pieces or in composite materials, as component of minerals, or in electrolytes. The notion of liberation is then not evident and its description very complex with different liberation scales.

Consequently, it is necessary to return to the basis of the theory of sampling hopping to understand the behaviour of such material during sampling. A fine description of the heterogeneity of constitution is then necessary. Unfortunately, it appears very difficult to obtain it because of the wide variety of WPCB, the lack of initial goods documentation and the difficulty to identify the origin after waste collection. The other way is to observe the variability appearing during the sampling stages and use statistical tools to analyse it in conjunction with the theory of sampling. For that, several experiments have been performed and detailed in previous papers<sup>1,2</sup>. Different kinds of interpretation of results have been done<sup>1,2,4</sup>, the current study trying to differentiate the variability due to sampling and the variability due to analytical protocols.

The first part of this paper shortly presents the experiment and discusses the observed variability. The tentative to look for the reason of the extent of this observed variability into the size (the mass) of the sample and its fineness partially fails, as expected. One of the causes of this failure is coming from the importance of the analytical error, the calculation of which being subject of the second part. The last part tries to isolate the sampling error from the observed variability by deducting the variance of the analytical error from the experimental variance to have the pure sampling variance. The contribution of the different components of the overall sampling error is then discussed.

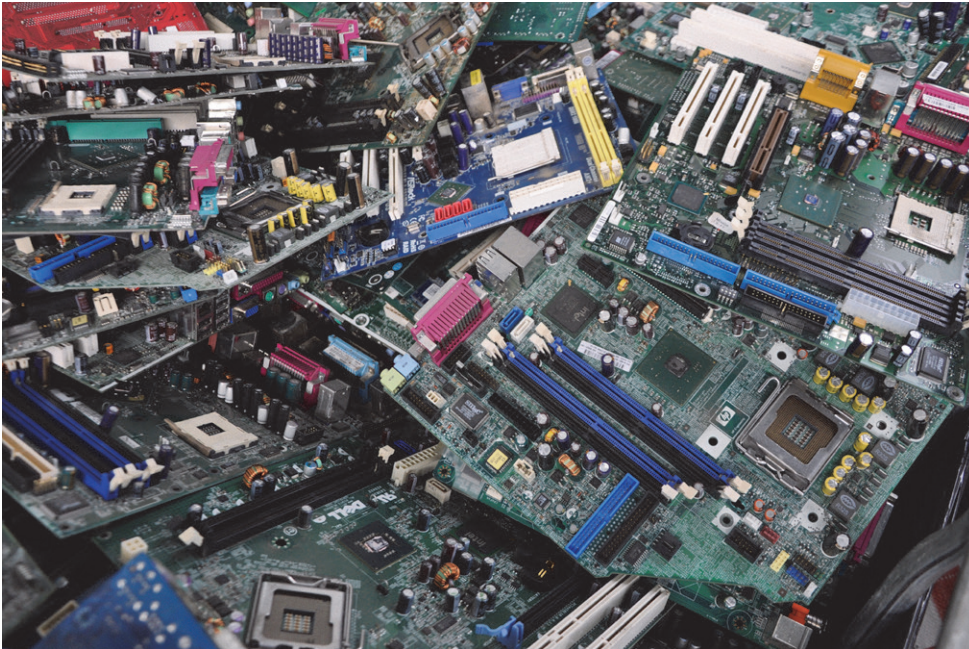

**Figure 1. A lot of WPCB illustrating the high heterogeneity of the material to be sampled.**

### Variability assessment study

As a human production, the constitution of the printed circuit board (PCB) in terms of electronic components and chemical composition of these components may be a priori known. In the real world, not only the documentation about identified types of PCB is difficult to obtain, but it is generally impossible to identify the type of PCB. It is why the heterogeneity of these pieces of equipment cannot be described by this way. In addition, after shredding, the heterogeneity of produced particles is very difficult to predict from the knowledge of PCB heterogeneity. Only an empirical statistical approach seems possible.

In this experiment, the objective is to obtain an estimate of the variability of the material composition when taking a sample from a lot of WPCB for chemical analysis. The variability assessment is performed for different sample preparation protocols, the analytical procedure for each metal content being the same for all sampling types. A great number of samples are drawn from the same lot for each protocol type with the objective to obtain the main parameters of the variability distribution. The variability in the content measurement results is mainly due to sampling error, but also to analytical error.

### Sample taking and preparation

Only one 526 kg lot of WPCB has been used for this experiment to reduce the risk of inter-lot variability (Figure 1). It has been ground to -30 mm (Figure 2 left). Due to components which are difficult to break (such as coils, transformers, or coolers), only 481 kg are passing 30 mm control sieve. Only this fraction is considered as the lot from which samples are taken. This lot is then homogenized and divided using a rotary splitter, one fourth of 122 kg being randomly selected for grinding to -10 mm with more than 96 % passing (Figure 2 right). After homogenization, the 122 kg are divided to obtain approximately 16 kg in three stages using a 60 mm riffle splitter, then divided to obtain four samples of approximately 4 kg in two stages using a 30 mm riffle splitter. Three of these samples have been ground to -2 mm using a Retsch SM 2000 laboratory shredder (Figure 3 left). Two of them have then been ground to -750  $\mu\text{m}$  (Figure 3 right). One of the -750  $\mu\text{m}$  samples has been divided and 2 kg have been ground to -200  $\mu\text{m}$  using a Poitemill knife mill. After homogenization, each ground sample of WPCB has been divided using a 15 mm riffle splitter, the obtained 2 kg being divided using a 5 mm riffle splitter to obtain numerous samples of 5 g, 2 g and 0.5 g as detailed in the Table 1. The 0.5 g samples have been obtained by scooping from 2 g splitting fractions. This procedure (Figure 4) has been described in detail by Hubau et al<sup>1</sup> and Touz  et al<sup>2</sup>.

**Table 1. List of generated samples.**

Sample name	Number of samples	Fineness	Mass
2 mm 5 g	24	2 mm	5 g
2 mm 2 g	16	2 mm	2 g
2 mm 0.5 g	16	2 mm	0.5 g
750 $\mu\text{m}$ 5 g	24	750 $\mu\text{m}$	5 g
750 $\mu\text{m}$ 2 g	16	750 $\mu\text{m}$	2 g
750 $\mu\text{m}$ 0.5 g	15	750 $\mu\text{m}$	0.5 g
200 $\mu\text{m}$ 5 g	16	200 $\mu\text{m}$	5 g
200 $\mu\text{m}$ 2 g	16	200 $\mu\text{m}$	2 g
200 $\mu\text{m}$ 0.5 g	16	200 $\mu\text{m}$	0.5 g



Figure 2. The lot of WPCB after shredding to -30 mm (left) and a quarter of that lot after shredding to -10 mm (right).



Figure 3. 4 kg sample of WPCB shredded to -2 mm (left) and another 4 kg sample shredded to -750 µm (right).

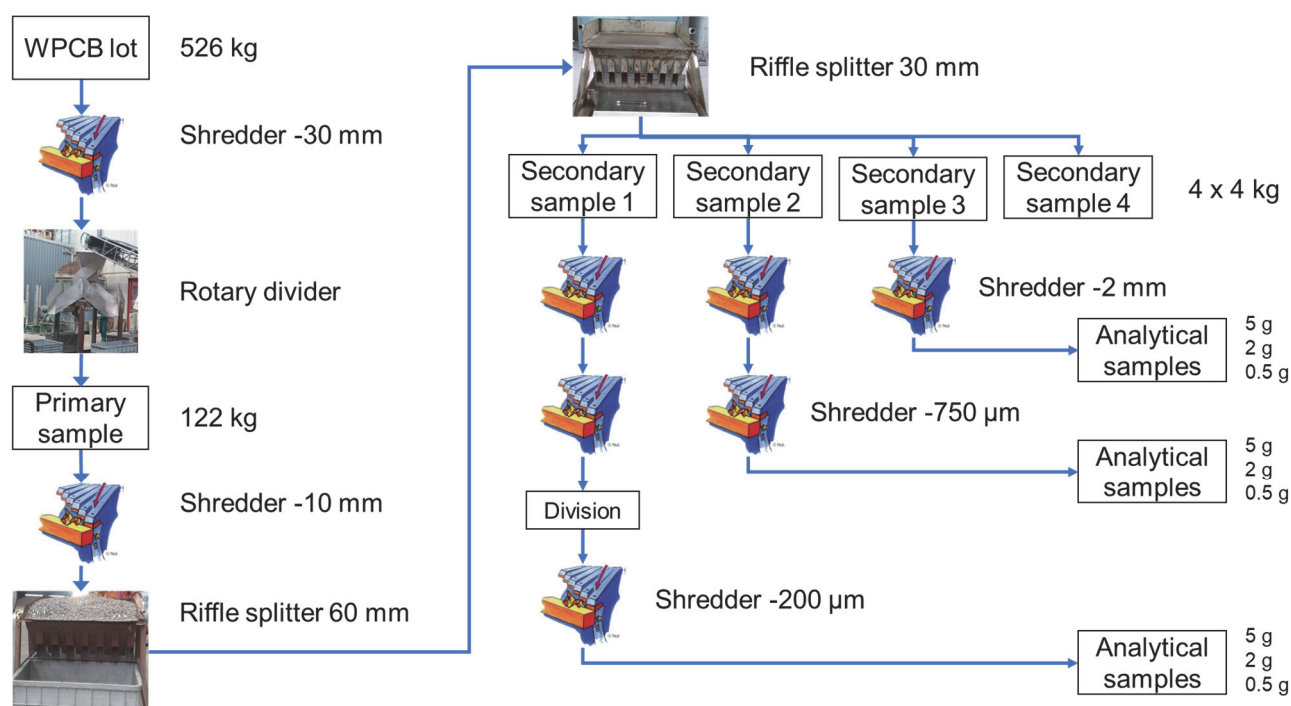

Figure 4. WPCB sampling procedure resulting in several kinds of samples for analysis.

#### Sample analysis for metal contents

These 159 samples have been analysed for Cu, Fe, Ni, Pb, Zn and Co contents following approximately the same procedure (Figure 5). Each sample of ground WPCB has been precisely weighed using a Sartorius MSU225P scales. The samples were dissolved in hot aqua regia (HNO<sub>3</sub>:HCl 1:3) at reflux, in a vessel equipped with a condenser. The solid/liquid ratio was

1/10 (weight/volume), and the contact time was about 2 h. Each leaching fraction was filtered over a 0.45 mm cellulose nitrate filter, and the leachate was diluted with a solution of  $\text{HNO}_3$  0.5 M. Details on the digestion process are given in Hubau et al<sup>1</sup>, including the control of remaining solid residues.

The concentrations of Cu, Fe, Ni, Pb, Zn and Co in the resulting solutions were determined by Flame Atomic Absorption Spectrometry FAAS on a Varian SpectraAA-300. The volume of these resulting solutions is 250 ml gauged with class A measuring flask, except for most of 750  $\mu\text{m}$  5 g samples for which a 200 ml flask has been used. Samples of these solutions have been taken for FAAS analysis after dilution depending on the analysed metal. Samples for analysis of Cu, Fe, Ni, Pb and Zn have been diluted by 200 except for 750  $\mu\text{m}$  5 g samples for which they have been diluted by 100 only. Dilution was manually performed by taking 100  $\mu\text{l}$  using a class A 10-100  $\mu\text{l}$  pipette which are diluted with  $\text{HNO}_3$  0.5 mol/l in a 20 ml class A measuring flask (10 ml in case of dilution by 100). Samples for analysis of Co have been diluted by 5 or 10 except for 750  $\mu\text{m}$  5 g samples for which they have not been diluted. Dilution by 5 and 10 was manually performed by respectively taking a volume of 2 or 1 ml using a class A pipette which is diluted in a 10 ml class A measuring flask. During FAAS measurement, an automatic dilution can be performed to adjust the content to the calibration curve range.

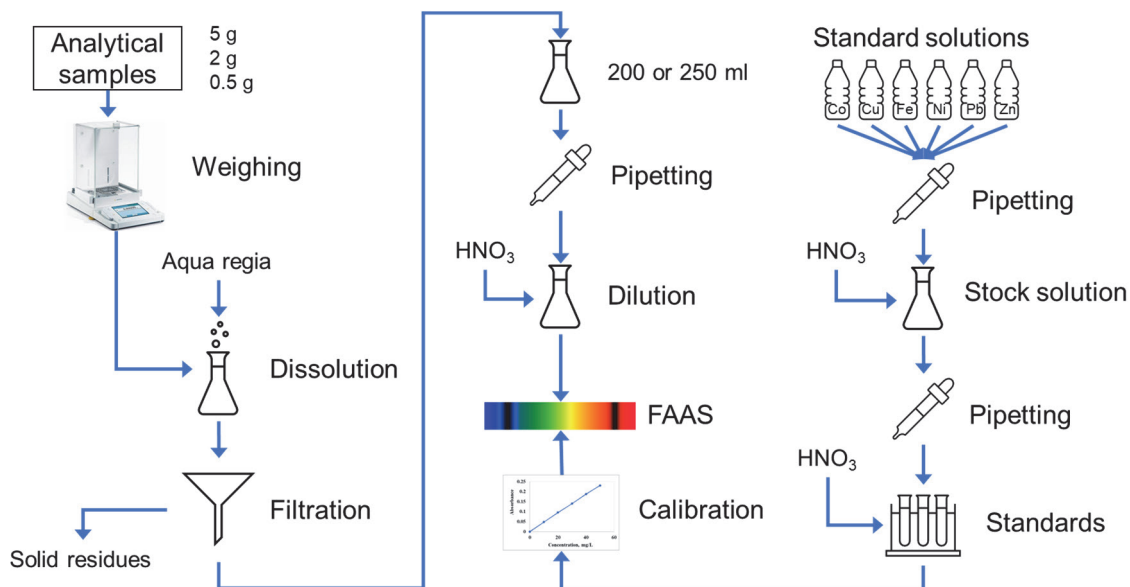

**Figure 5. Analysis and FAAS calibration procedures.**

**Calibration curve determination.** The FAAS calibration curve is obtained by analysis of a set of four standards obtained by dilution with various dilution factors of a stock solution with a known composition in terms of Cu, Fe, Ni, Pb, Zn and Co contents (Figure 5). To consider the matrix effect, the ratios between the contents in the stock solution are close to the expected ones in the analysed solutions. A blank solution (named zero) is also used for the 0 mg/l calibration.

The stock solution composition is 20 mg/l of Cu and Fe, 5 mg/l of Pb, 2 mg/l of Ni and Co, and 1 mg/l of Zn. It is obtained by respectively diluting 4000  $\mu\text{l}$ , 1000  $\mu\text{l}$ , 400  $\mu\text{l}$  and 200  $\mu\text{l}$  of 1000 mg/l standard solutions of corresponding metals into a 200 ml measuring flask completed with a solution of  $\text{HNO}_3$  0.5 mol/l.

Four standards, numbered 1, 2, 3 and 4, are obtained by dilution of this stock solution. The standard 4 correspond to the stock solution itself. The standards 1, 2 and 3 are obtained by respectively pipetting 5 ml, 10 ml and 15 ml of stock solution completed by  $\text{HNO}_3$  solution in a 20 ml measuring flask. The Table 2 summarizes the constitution of the standards for calibration from the stock solution.

**Table 2. Stock solution and calibration standards constitution.**

	Co	Cu	Fe	Ni	Pb	Zn
Standard solution contents (mg/l)	1000	1000	1000	1000	1000	1000
Pipetting volume ( $\mu\text{l}$ )	400	4000	4000	400	1000	200
Stock solution contents (mg/l)	2	20	20	2	5	1
Calibration standard 1 contents (mg/l)	0.5	5	5	0.5	1.25	0.25
Calibration standard 2 contents (mg/l)	1	10	10	1	2.5	0.5
Calibration standard 3 contents (mg/l)	1.5	15	15	1.5	3.75	0.75
Calibration standard 4 contents (mg/l)	2	20	20	2	5	1

The calibration curve for each metal is obtained by measuring the absorbance of the zero solution and the four standards with fitting of the obtained points with a linear function for Co, Fe and Ni, or a quadratic function for Cu, Pb and Zn. These functions are used to obtain the metal contents in the leachate solution from the measurements of the absorbance.

#### Observed variability

The Figure 6 gives the average values of the metal contents for each sample type for which the error bars indicate the plus and minus one standard deviation considered as the observed variability.

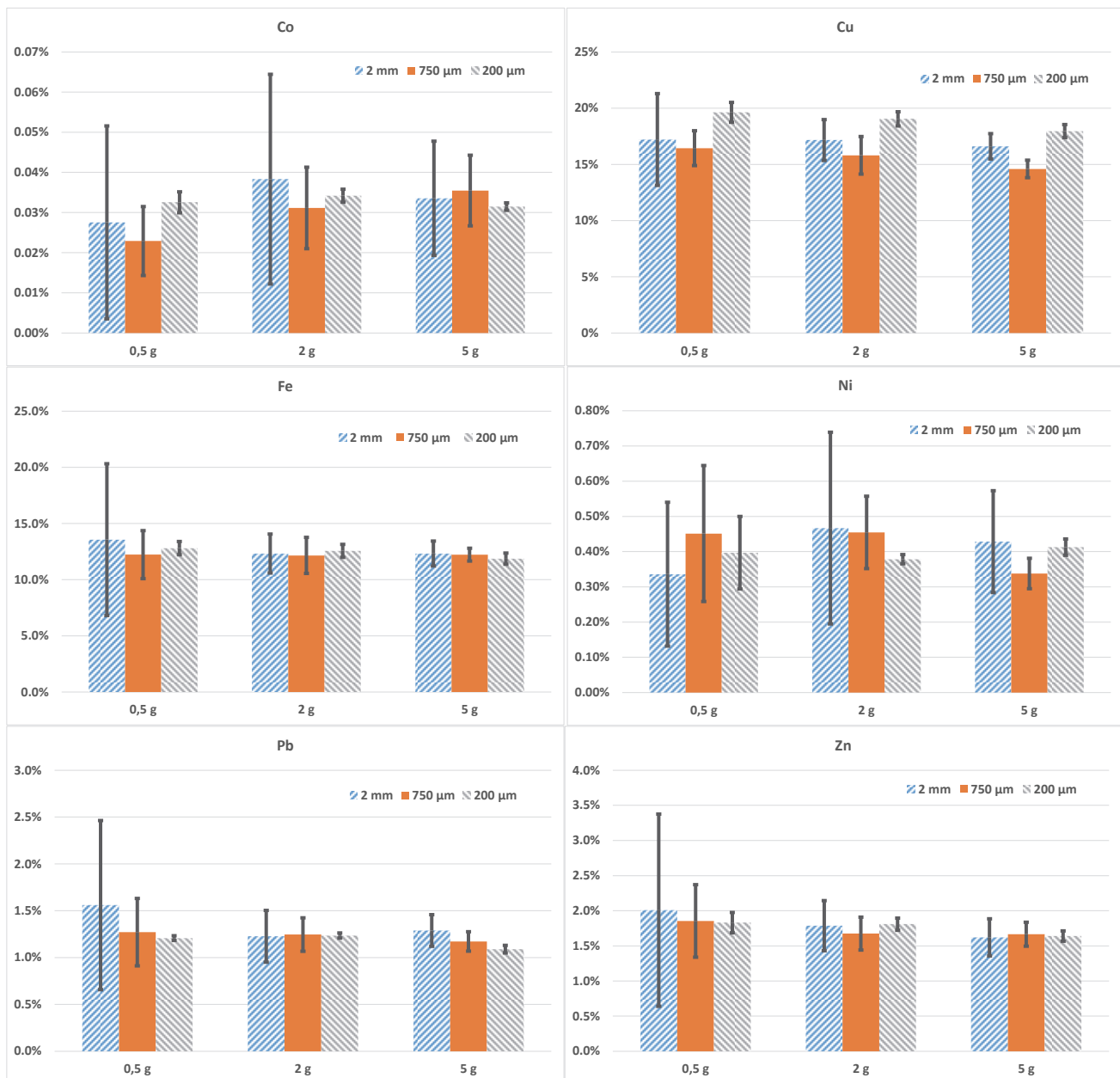

**Figure 6.** Average content (%w/w) per sample mass and sample fineness for Co, Cu, Fe, Ni, Pb and Zn. The error bars indicate the  $\pm$  one standard deviation of the variability.

As expected, the general trend is a decreasing variability with decreasing maximum particle size of the sample. Despite some exceptions, the general trend is a decreasing variability with increasing sample mass. In some cases (Co 0.5 g, Cu all masses and Ni 5 g), the difference between average values of the different fineness seems larger than the internal variability. This is because all the samples of a given fineness, whatever the sample mass, are coming from the same 4 kg sample taken from the initial 122 kg sample ground to -10 mm. It appears there is important heterogeneity between the 10 mm pieces of WPCB with certainly some ones generating a nugget effect, hence this larger difference. After grinding, this effect disappears.

### Sources of variability

Observing the Figure 1, it clearly appears the main parameters influencing the variability are the mass and the fineness of the analytical sample. As the relative variance of the sampling error depends on the mass of sample and on its intrinsic heterogeneity, itself depending on the fineness of the material, it seems reasonable to consider the sampling error as main source of variability. But, as it is shown in the following sections, the other component of the overall measurement error, the analytical error, is also depending on the mass of sample.

Even though the Pierre Gy's simplified formula cannot be applied in this case (the particle density distribution depends on their size), a similar formula can be used to estimate the impact of the analytical error:

$$\sigma^2 = \frac{IH}{M_s} = \frac{Kd^3}{M_s}$$

Assuming the observed variance  $\sigma^2$  is inversely proportional to the mass of sample  $M_s$  (the lot mass, 4 kg, being large compared to the sample mass) with the intrinsic heterogeneity  $IH$  as proportionality factor, and proportional to the volume of largest particles  $d^3$ , the parameter  $K$  can be calculated for each sample type (Table 3). The large difference between the  $K$  values for a given analyte suggests:

- The analytical error plays a non-negligible role in the overall measurement error.
- The simplified formula cannot be applied in this case.



**Table 3. Values of the K parameter in g/cm<sup>3</sup>.**

Sample type	Co	Cu	Fe	Ni	Pb	Zn
2 mm 5 g	112	3	5	71	11	17
2 mm 2 g	116	3	5	85	13	10
2 mm 0.5 g	48	4	15	23	21	29
750 μm 5 g	731	34	25	194	92	124
750 μm 2 g	503	53	82	243	98	93
750 μm 0.5 g	167	10	36	216	95	92
200 μm 5 g	534	652	1094	1936	867	1279
200 μm 2 g	602	279	528	300	121	561
200 μm 0.5 g	363	127	130	4207	27	393

To estimate the relative contribution of these two hypotheses, it is necessary to estimate the analytical error, subject of the next section.

### Calculation of the analytical error

In our case, the analysis part of the global experiment starts with the last WPCB sample weighing just before digestion. The analytical error is coming from the imperfection of the analysis protocol, of the devices used to perform intermediate measurement and of the operator. To calculate the analytical error, it is necessary to decompose the procedure in its different stages, identify and classify all the sources of uncertainty at each stage, calculate the first moments of the distribution of these uncertainties when possible, or at least estimate their magnitude, then calculate the full analytical error using error propagation rules.

The metal content  $C_{sol}$  in the solid WPCB sample is given by the formula:

$$C_{sol} = \frac{V_{dig}V_{dil}\mathcal{F}(A; \mathcal{E})}{M_sV_pR_{FAAS}}$$

Where:

- $M_s$  is the mass of solid sample before digestion.
- $V_{dig}$  is the volume of solution after digestion and completion in the measuring flask.
- $V_p$  is the volume of solution pipetting for dilution.
- $V_{dil}$  is the volume after dilution.
- $R_{FAAS}$  is the automatic dilution factor of FAAS (= 1 if there is no automatic dilution).
- $\mathcal{F}(A; \mathcal{E})$  is the metal content in the diluted solution calculated as a function of the measured absorbance  $A$ . This function is fitting the calibration curve with a set of parameters  $\mathcal{E}$  which have been obtained during calibration stage.

The more evident sources of uncertainty are coming from the measurement of the above parameters. But some other sources must be considered:

- After digestion, the solid residues can contain remaining metals which have not been subject to digestion. The coarser are the particles, the larger is the risk of such remaining metals, due to non-liberation or to longer leaching time. The residue analysis did not detect any remaining metals or at very low quantity compared to total amount for the 750 μm fineness<sup>1</sup>.
- The matrix effect during FAAS has been partially considered by using a stock solution, then standards, with a composition close to the one of the analysed solutions. However, many other elements (as Al, Mn, organics) were not considered in the standards.

### Sample mass measurement

The mass of sample is measured using precision scales. The main sources of uncertainty are coming from the imperfection of the device which are the readability, the repeatability, the linearity, the off-centre, the temperature sensitivity and the calibration test weight. The sample is put in the digestion flask for weighing. The mass of the flask constitutes the tare (approximately 150 g), the measurement of which is also source of uncertainty.

The scales being regularly calibrated and controlled, the risk of bias is low and negligible compared to the standard deviation. The variance of the relative measurement error for the mass  $M$  is given by the formula:

$$\sigma^2(M) = \sigma_R^2 + \frac{\sigma_A^2}{M^2}$$

Where:

- $\sigma_R^2$  is the relative component coming from the off-centre, the temperature sensitivity and the calibration test weight.
- $\sigma_A^2$  is the absolute component coming from the readability, the repeatability and the linearity.

The mass of sample  $M_s$  being the difference between the total mass  $M_T$  and the tare mass  $M_t$ , the relative variance of the sample mass measurement is:

$$\sigma^2(M_s) = \frac{M_T^2\sigma^2(M_T) + M_t^2\sigma^2(M_t)}{M_s^2}$$

The measurement error (with 95 % confidence level) for the three masses are then 0.022 % for 5 g, 0.054 % for 2 g and 0.22 % for 0.5 g.

### Digestion volume measurement

The volume of solution after digestion and completion with  $\text{HNO}_3$ ,  $V_{dig}$ , is measured using a 200 ml or 250 ml class A measuring flask. The main sources of uncertainty are coming from the tolerance of the flask ( $\pm 0.15$  ml), the operator sensitivity for reaching the mark, which can be estimated to two drops of liquid ( $\pm 0.1$  ml), the temperature variation ( $\pm 3^\circ\text{C}$ ) causing liquid dilatation (supposed the same as water).

The calculated measurement error is 0.18 % for the 250 ml flask and 0.19 % for the 200 ml one.

### Pipetting volume measurement

The volume of solution pipetted from the previous flask for dilution,  $V_p$ , is measured using a 10-100  $\mu\text{l}$  pipette for dilutions by 200 and 100, a 100-1000  $\mu\text{l}$  pipette for dilution by 10 and a 500-5000  $\mu\text{l}$  pipette for the dilution by 5. The main sources of uncertainty are coming from the tolerance of the pipette, the graduation linearity, the repeatability, the temperature variation ( $\pm 3^\circ\text{C}$ ) causing liquid dilatation (supposed the same as water).

The calculated measurement error is 1.1 % for the pipetting of 100  $\mu\text{l}$  or 1 ml, and 2.2 % for the pipetting of 2 ml.

### Dilution volume measurement

The previous pipetted volume is poured in a 10 ml or 20 ml class A measuring flask and completed with  $\text{HNO}_3$  to reach the dilution volume,  $V_{dil}$ . The main sources of uncertainty are coming from the tolerance of the flask ( $\pm 0.025$  ml and  $\pm 0.03$  ml respectively), the operator sensitivity for reaching the mark, which can be estimated to one drop of liquid ( $\pm 0.05$  ml), the temperature variation ( $\pm 3^\circ\text{C}$ ) causing liquid dilatation (supposed the same as water).

The calculated measurement error is 0.66 % for the 10 ml flask and 0.37 % for the 20 ml one. The error associated to the dilution factor is given in Table 4.

**Table 4. Measurement error associated to the dilution factor (95 % confidence level).**

Dilution factor	5	10	100	200
Pipetting volume (ml)	2	1	0.1	0.1
Dilution volume (ml)	10	10	10	20
Measurement error	2.26 %	1.27 %	1.27 %	1.15 %

### Automatic dilution error

Despite the manual dilution, it may be necessary to have an additional dilution performed automatically by the FAAS system. This automatic dilution being done using peristaltic pumps, the error on the expected dilution factor,  $R_{FAAS}$ , is estimated to 2 % by the manufacturer.

For low dilution factor, this error is comparable to the one we can have by manual dilution. But for higher dilution factors, it is more accurate to perform manual dilution. Especially as this automatic dilution arises after a manual dilution, the total dilution error being the sum of both. It is preferable to directly reach the range of contents of the calibration curve by manual dilution, avoiding the risk to have an automatic dilution.

### Uncertainty of the stock solution composition

The stock solution being used to produce standards, the uncertainty about its composition takes part in the error associated to the parameters of the function fitting the calibration curve. The concentration  $C_M$  of the metal M in the stock solution is given by:

$$C_M = \frac{C_{sM} V_{pM}}{V_f}$$

Where:

- $C_{sM}$  is the concentration of metal M in the standard solution: 1000 mg/l with a tolerance of  $\pm 10$  mg/l.
- $V_{pM}$  is the volume of pipetted standard solution: 4 ml for Cu and Fe, two times 200  $\mu\text{l}$  for Co and Ni, 1 ml for Pb and 200  $\mu\text{l}$  for Zn.
- $V_f$  is the volume after dilution in the 200 ml class A measuring flask.

The errors with 95 % confidence level for the estimation of the stock solution composition are 1.49 % for Co and Ni contents, 1.35 % for Cu and Fe contents, 2.70 % for Pb content and 1.50 % for Zn content.

### Uncertainty of the calibration standards composition

The standards 1, 2 and 3 are obtained by manual dilution of 5 ml, 10 ml and 15 ml of stock solution respectively into a 20 ml class A measuring flask. The pipetted volume is done using the same 5 ml pipette. The standard 4 is the stock solution itself. The Table 5 gives the error with 95 % confidence level associated to the expected composition of the standards.

**Table 5. Composition error (95 % confidence level) of the calibration standards.**

Calibration standard	Co	Cu	Fe	Ni	Pb	Zn
1	1.64 %	1.52 %	1.52 %	1.64 %	2.78 %	1.65 %
2	1.62 %	1.50 %	1.50 %	1.62 %	2.77 %	1.63 %
3	1.62 %	1.49 %	1.49 %	1.62 %	2.77 %	1.63 %
4	1.50 %	1.35 %	1.35 %	1.50 %	2.70 %	1.51 %

### Absorbance measurement error

The absorbance is given in units of absorbance (UA) and varies from small negative value (corresponding to a null concentration) to 0.55 UA. The sources of uncertainty can be divided in three main groups according to their origin: the flame, the light source and the optics<sup>3</sup>. Three uncertainty components are then assumed: stability with  $\pm 0.0003$  UA, base line with  $\pm 0.0003$  UA and repeatability with  $\pm 0.0002$  UA.

### Linear regression parameters error

If the calibration curve is supposed to be a linear function of type  $y = ax$ , the parameter  $a$  is obtained by regression on a set of four standard measurements  $(x_i; y_i)$ ,  $x_i$  being the metal content in the standard and  $y_i$  the measured absorbance. Its value is given by:

$$a = \frac{\overline{xy}}{\overline{x^2}}$$

Where:

$$\overline{xy} = \frac{\sum_i w_i x_i y_i}{\sum_i w_i}$$

$$\overline{x^2} = \frac{\sum_i w_i x_i^2}{\sum_i w_i}$$

$$w_i = \frac{1}{\sigma^2(y_i) + a^2 \sigma^2(x_i)}$$

The absolute variances of the error associated to the absorbance measurement ( $\sigma^2(y_i)$ ) and to the standard composition estimate ( $\sigma^2(x_i)$ ) have been defined above. Consequently, the uncertainty about the value of the regression parameter is given by its relative variance:

$$\sigma^2(a) = \frac{1}{a^2 \sum_i w_i x_i^2}$$

The error (95 % confidence level) associated to the regression parameter for Co, Fe and Ni analysis is then 1.07 %, 0.99 % and 1.07 % respectively. The variance of the measurement error associated to the content in the solution,  $\mathcal{F}(A; a)$ , for the measured absorbance  $A$  is given by:

$$\sigma^2(\mathcal{F}(A; a)) = \sigma^2(a) + \frac{\sigma^2(A)}{A^2}$$

Where  $\sigma^2(A)$  is the absolute variance of the absorbance measurement error.

### Overall analytical error

When combining the components of all these sources of errors, the relative variance of the overall analytical error is given by the sum of the individual relative variances:

$$\sigma^2(C_{sol}) = \sigma^2(M_s) + \sigma^2(V_{dil}) + \sigma^2(V_{dil}) + \sigma^2(V_p) + \sigma^2(R_{FAAS}) + \sigma^2(\mathcal{F}(A; a))$$

As some of these components depends on the content of the analyte, the relative analytical variance and, consequently, the width of the 95 % confidence interval, must be calculated for each analysed sample. The Table 6 gives the range of calculated errors, coming from the range of measured contents, for each sample type.

The ranges of errors clearly show that the average value depends on the mass of analytical sample while the width of this range depends on the fineness of that sample. The second point can be easily explained as it is linked to the sampling error which is expected to decrease when the particle size decreases for a given sample mass, resulting in a narrower range of contents. The first point is more linked to the dilution process which uses the same factor whatever the initial sample mass, except for Co. Consequently, the concentration in the analysed solution is proportional to the mass of initial analysed sample resulting in a lower measured absorbance for small samples. As the main dependence of the relative variance with the content is coming from the absorbance measurement error which has a constant absolute variance, too low absorbance results in a large measurement error.

In fact, the dilution factor must be adapted to the expected content. If a factor of 200 seems adapted for the 5 g samples, it must be reduced to 80 and 20 for the 2 g and 0.5 g respectively.

**Table 6. Minimum and maximum analytical errors\* observed per sample type for Co, Fe and Ni contents.**

Sample type	Co analytical error		Fe analytical error		Ni analytical error	
	Minimum	Maximum	Minimum	Maximum	Minimum	Maximum
2 mm 5 g	1.8 %	2.7 %	3.3 %	4.1 %	1.7 %	2.3 %
2 mm 2 g	1.8 %	4.7 %	1.7 %	1.8 %	1.8 %	4.5 %
2 mm 0.5 g	3.1 %	23.9 %	1.6 %	2.6 %	7.6 %	77 %
750 $\mu$ m 5 g	2.3 %	2.3 %	2.6 %	2.6 %	1.8 %	2.1 %
750 $\mu$ m 2 g	2.6 %	3.1 %	1.7 %	1.8 %	2.4 %	4.2 %
750 $\mu$ m 0.5 g	4.3 %	12.2 %	3.0 %	4.8 %	6.7 %	21.8 %
200 $\mu$ m 5 g	2.6 %	2.6 %	1.6 %	1.6 %	1.9 %	2.0 %
200 $\mu$ m 2 g	2.7 %	2.8 %	1.7 %	1.8 %	3.4 %	4.2 %
200 $\mu$ m 0.5 g	4.1 %	5.4 %	3.4 %	4.1 %	7.2 %	16.4 %

\* The term "error" is used here as the width of the 95 % confidence interval calculated as 1.96 times the standard deviation. Calculated errors with value larger than 20 % are displayed just to indicate they are large, but their value is not in accordance with some assumptions which have been done for their estimation, such as the error propagation rule and the distribution normality.

## Discussion about sampling error

As all samples of a given fineness have been drawn from the same 4 kg lot, the observed variability includes this last sampling stage (laboratory sample taking) and the analysis. Consequently, by subtracting the average variance of the analytical error from the variance of the observed variability, it remains the variance of the last stage sampling error.

The Table 7 gives the obtained sampling error (95 % confidence level) and the associated intrinsic heterogeneity *IH* for the measurement of the Co, Fe and Ni contents per sample type.

**Table 7. Observed sampling error\* and associated intrinsic error per sample type for Co, Fe and Ni contents.**

Sample type	Sampling error (95 %)			Intrinsic heterogeneity** (g)		
	Co	Fe	Ni	Co	Fe	Ni
2 mm 5 g	84 %	18 %	67 %	1.165	0.05168	0.7389
2 mm 2 g	134 %	28 %	115 %	1.144	0.04843	0.8369
2 mm 0.5 g	171 %	98 %	116 %	0.4036	0.1321	0.1849
750 µm 5 g	49 %	8.7 %	25 %	0.2928	0.009353	0.07750
750 µm 2 g	64 %	26 %	45 %	0.2736	0.04477	0.1317
750 µm 0.5 g	74 %	35 %	83 %	0.07519	0.01632	0.09532
200 µm 5 g	5.2 %	8.1 %	10.8 %	0.004228	0.01037	0.01844
200 µm 2 g	9.3 %	8.9 %	5.7 %	0.005117	0.004689	0.001933
200 µm 0.5 g	15 %	8.2 %	49 %	0.002777	0.000925	0.03278

\* The term "error" is used here as the width of the 95 % confidence interval calculated as 1.96 times the standard deviation. Calculated errors with value larger than 20 % are displayed just to indicate they are large, but their value is not in accordance with some assumptions which have been done for their estimation.

\*\* The term "intrinsic heterogeneity" is abusive in this case as this parameter is defined for the fundamental sampling error (FSE) while it is used here for the overall sampling error which includes FSE and other non-negligible components. It is named "pseudo intrinsic heterogeneity" in the following discussion.

All the samples of a given fineness have been drawn from one lot of approximately 4 kg ground to the target, except for the -200 µm lot which is of 2 kg. Consequently, the obtained sampling error only concerns the last stage of sampling when taking 5 g, 2 g or 0.5 g of sample from a lot of 4 kg or 2 kg. In all cases, the mass of lot can be considered as large compared to the mass of sample and its influence on the sampling error is negligible. As expected, it is well observed the obtained sampling error is decreasing when the mass of sample increases, and that for all fineness and analytes (except for 200 µm 2 g samples for which the variance of the observed variability was particularly small for Ni content and high for Fe content). But the values of the intrinsic heterogeneity indicate the variance of the total sampling error is not inversely proportional to the mass of sample.

As the 4 kg (or 2 kg) lots have been obtained by division of one 122 kg lot which had been previously ground to -10 mm, it is possible to compare the effect of fineness: the samples of the same mass have an observed sampling error decreasing when the size of the largest particles decreases, as expected. But the intrinsic heterogeneity is not proportional to the third power (or a smaller power) of that maximum size indicating the simplified formula of Pierre Gy cannot be used.

The main sampling error components which must be considering in this case are:

- The fundamental sampling error (FSE), the variance of which is clearly inversely proportional to the mass of sample. The intrinsic heterogeneity associated to the FSE is certainly not proportional to the unit mass of the largest particles due to the nature of the components bearing the followed metals which have different behaviours during grinding and have a wide range of densities. Being theoretically defined as the minimum sampling error when the sample drawing follows a strict and ideal equiprobability rule, this component is independent of the sampling conditions, the other components being in charge to consider the gap between ideal and reality.
- The grouping and segregation error (GSE), the variance of which is proportional to the one of FSE with both grouping and segregation factors, following the Pierre Gy's approach<sup>5</sup>. But these factors are not constant regarding the mass of sample and are very difficult to estimate (even though their product is frequently assumed to be one). In the present case, the use of riffle splitters by experimented operators from the lot to the analytical sample let think a limited effect of grouping and segregation against the equiprobability rule. There is an infringement of rules for the 0.5 g sample drawing which has been done by scooping. Fortunately, scooping was performed from a 2 g intermediate sample obtained by riffle splitting and four samples was taken for each 2 g, preventing unacceptable bias on the determination of the mean value. The counterpart is a risk of larger observed variability for these kinds of 0.5 g samples, due to GSE, but, in opposition to any expectation, the contrary is observed with a lower pseudo intrinsic heterogeneity for two thirds of sample types (Table 7).
- The increment delimitation error (IDE) and increment extraction error (IEE) are mainly linked to the increment taking device, its design, its size, and its use. The riffle splitter has been mainly used for this experiment. It is not the best system for sample division, but it can be very efficient if it is well used with a size well adapted to the maximum particle size and the sample mass, which seems the case here. These components are due to side effect generating a relative variance which is constant versus the sample mass. This variance can be neglected when the volume in which the side effect occurs is small compared to the total volume of the sample. This is the case for this experiment.

To summarize, it appears the calculated variance of the sampling error is only partially inversely proportional to the sample

mass and the obtained pseudo intrinsic heterogeneity is decreasing as the sample mass reaches 0.5 g, quite unexpectedly. The reasons of that can be:

- The analytical error is wrongly estimated due to some mistakes in parameter estimations. Consequently, the sampling error is wrongly estimated.
- The observed variability does not reflect the true variability because of insufficient number of samples or because of conditional probability due to the successive division process.
- In the grouping and segregation error (GSE), the segregation and grouping factors are higher for larger samples due to interaction between particles (electrostatic effects, entanglement) which can be more frequent when there is more material to divide. This effect can also generate IDE and IEE.

Deeper investigation and additional experiments must be conducted to try to answer these questions.

## Conclusion

This approach trying to separate analytical error and sampling error from the experimentally observed variability in sample analysis had as objective to better understand the behaviour of the material during the sampling stages and propose a sampling protocol well adapted to the WPCB. If part of this questioning has been answered, other part remains, and additional questions arose.

The analytical error has been calculated by considering the full process of analysis from the weighing of the WPCB sample for analysis to the results delivered by the FAAS device. If some values of analytical process parameters remain uncertain, the general error calculation method constitutes a base line for this kind of procedures. In this case, it is very difficult to verify this error estimate using standards as such standards do not exist in the market and cannot be easily produced with sufficient level of accuracy. Only the last stage of FAAS of solution can be controlled by liquid standards and subject to statistical analysis.

The procedure to estimate the sampling variability has also been questioning during this study and further investigations will necessitate more attention in the general protocol, in the choice of devices, and in the practice. The division process is mainly concerned by this point, but also the grinding stages as this kind of WPCB material is very difficult to grind, specifically for fine grinding. This difficulty calls the opportunity to use fine grinding for sampling in mind. Other sample preparation techniques may be easier without reducing the representativeness of the sample.

In any case, further investigations are necessary, not limited to the six metals studied here, to define a sampling and analytical procedure which is technically and scientifically accurate enough and industrially acceptable. Indeed, if major recycling consumer companies, mainly metal producers, have their own sampling and analytical procedures, a lot of smaller companies involved in WEEE recycling are looking for methods of waste value estimation which are accurate and relatively simple to carry out. In such a way, accuracy and transparency for material valuation in commercial transactions between the different stakeholders of the recycling can be a leverage for the growth of the circular economy.

## ORCID iDs

S. Brochot: <https://orcid.org/0000-0002-9015-9693>

A. Hubau: <https://orcid.org/0000-0002-3896-7220>

S. Touzé: <https://orcid.org/0000-0002-0840-4494>

## References

1. A. Hubau, A. Chagnes, M. Minier, S. Touzé, S. Chapron and A.-G. Guezennec, "Recycling-oriented methodology to sample and characterize the metal composition of waste Printed Circuit Boards", *Waste Management*. **91**, 62–71 (2019). <https://doi.org/10.1016/j.wasman.2019.04.041>
2. S. Touzé, S. Guignot, A. Hubau, N. Devau and S. Chapron, "Sampling waste printed circuit boards: Achieving the right combination between particle size and sample mass to measure metal content", *Waste Management*. **118**, 380–390 (2020). <https://doi.org/10.1016/j.wasman.2020.08.054>
3. A. Petrov, G. Gentsheva, I. Havezov and E. Ivanova, "Determination of the Uncertainty of the Flame Atomic Absorption Spectrometer for Copper, Cobalt, Cadmium, and Nickel", *Analytical Letters*. **42**, 2509–2519 (2009). <https://doi.org/10.1080/00032710903243513>
4. A. Hubau, S. Touzé, S. Brochot and P. Wavrer, "Estimation of uncertainty for measuring metals content in waste printed circuit boards", in *Proceedings 10th World Conference on Sampling and Blending (WCSB10)*, TOS forum (2022).
5. P. Gy, *Hétérogénéité, Echantillonnage, Homogénéisation, Ensemble cohérent de théories*, Masson, Paris (1988).

## Sampling in a precious metals refining plant – A practical approach for a complex problem

Bert Pauels

Umicore Precious Metals Refining, Hoboken (Belgium), E-mail: bert.pauels@umicore.com

**Umicore Precious Metals Refining is one of the world's largest precious metals recycling facilities. This plant recycles very diverse waste streams containing precious and other non-ferrous metals. More than 200 different types of raw materials are being processed here, varying from complex mining concentrates and refining residues coming from the mining industry and other smelters up to precious metals containing production scraps and end-of life materials such as electronic scrap and car catalysts. All these materials need to be sampled and analysed, of course, to determine the metal content (and so the value) of each individual lot. It is clear that heterogeneity rules in this process! Next to the obvious heterogeneity of the material itself, there is also a huge variety e.g. in lot size, in packaging, in physical appearance of the different materials, ... which is also to be taken into account during the sampling process. To take all these hurdles, the necessary resources are – unfortunately... – not unlimited. In this article we will gain more insight on how this complex problem is tackled in practice within Umicore, with respect for the Theory of Sampling. A couple of major specific sampling lines have been developed and designed in particular to be able to deal with the variety in physical appearance of the materials itself. Additionally, a large number of sampling procedures are made up in a modular way, to be able to cope with the necessary flexibility demanded for. Some examples will be illustrated and described more in detail, with specific attention to the most important influencing circumstances. Furthermore, the way the overall performance and quality of this whole process is supervised, will be explained. And finally, we'll discuss some special cases where “nothing seems to be what expected for”...**

### Umicore Precious Metals Refining

Precious metals have been used since the beginning of time for their beauty and nobility in jewellery, but today their technical properties are very important as well. Examples of these properties are firstly excellent electrical conductivity, therefore utilized in electronics, and secondly unique catalytic properties as used for e.g. in car catalysts or petrochemical catalysts. As global demand for these metals continues to rise, more low-quality ores are mined, leading to an overall decrease in average ore grade and a subsequent increase in energy use for the extraction of these metals. Thanks to their limited reactivity however, precious metals are endlessly recyclable, without loss of quality. Recycling these metals can be done using much less energy than is needed during primary production<sup>1</sup>. A major reason for this favourable energy balance is the relative richness of “ores” such as waste electronic scrap and spent automotive catalysts.

Since 1887 in Hoboken (Belgium), near the port of Antwerp, Umicore has had a long tradition in refining precious metals. In the last decades, the plant went through an extreme makeover, transitioning from a complex Pb-Cu-Ni concentrate smelter and refiner into one of the world's largest recycling facilities for precious metals. Due to its unique and innovative technology, UPMR is able to treat a wide range of complex precious metal bearing materials and recover 17 different metals efficiently, while applying world class environmental standards.

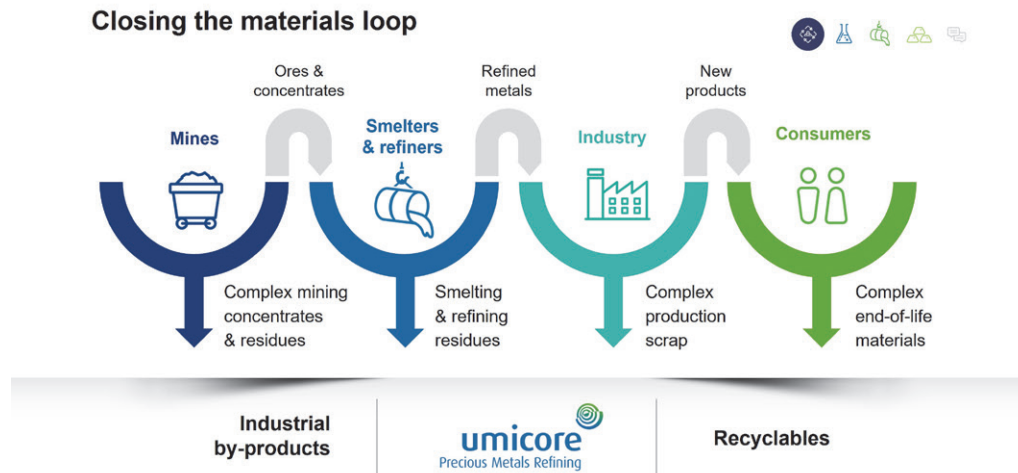

Figure 1. Umicore Precious Metals Refining, Hoboken – Belgium

## Incoming materials

UPMR is a world market leader in the assay-based recycling of complex waste streams containing precious and other non-ferrous metals. The plant offers eco-efficient smelting and refining services for precious metal bearing materials such as industrial by-products coming from other non-ferrous industries and, on the other hand, recyclables consisting of a large variety of end of life products containing precious metals.

Typically, the treated industrial by-products include: dross, precious metals-containing slag, matte, flue dust, hydrometallurgical residue, filter cake, tankhouse slimes and copper cement. Those products do not only come from other non-ferrous industries such as the copper, lead and zinc industry but may also come from other precious metals industries. Also complex concentrates (with a high degree of impurities) and by-products (such as gold on carbon or sludges) coming from mining operations are treated in the Hoboken plant.



**Figure 2. Overview of incoming materials**

Nowadays, precious metals are crucial, yet often invisible in our everyday life. They are key materials that enable consumer electronics to function, found in our mobile phones and computers. They also keep our air clean in automotive catalysts or support key industrial processes through industrial catalysts. As explained above, UPMR has evolved over time to efficiently recycle the precious metals coming of those end of life products from the consumer market, and is so turning the waste of yesterday into the materials of tomorrow. Typically, the recyclables treated in the plant are products such as electronic scrap (e-scrap), spent automotive catalysts, spent industrial catalysts and bottom ashes coming from incineration furnaces.

## Sampling and assaying

The wide variety and complexity of incoming materials mean that sampling and assaying are of crucial importance for reliable and efficient recycling. An accurate determination of the composition of the incoming materials is not only the base for the refining agreement with the customer (his final financial yield after all is based on the valuable metal content of the incoming material), but it also strengthens the knowledge about the exact composition of the feed, allowing the plant to tune its processes and to define optimal processing routes for every kind of feed material.

The full range of industrial by-products and recyclable materials are sampled on site at Hoboken, close by the operations. By means of an "à la carte" approach, each and every material gets its own dedicated sampling process, mostly in dedicated equipment. Often, these processes and technologies are in-house developed. This will be explained more in detail further below.

## Heterogeneity rules

As already described, a wide variety of materials arrives at the Hoboken plant. Yearly, about 8000 lots of more than 200 different types of raw materials are entering the plant, and need to be sampled before being processed in the smelter. Next to this enormous diversity of materials, there is of course also the obvious heterogeneity within each type of material. Both constitutional and distributional heterogeneity<sup>2,3</sup> play of course an important role in how the material is finally sampled. But there is a lot more which is influencing the final way of sampling.



**Figure 3. Diversity within incoming recyclables**

Heterogeneity is also very much observed within the variety of the intrinsic value of the incoming material. This value can vary from nearly 1 €/kg up to more than several thousands €/kg, depending of course on the kind and amount of precious metals the material contains. To reduce financial risks, both for the customer as for the refiner, lot sizes are also determined by this value, and will be limited to a certain threshold, mostly depending on the type of material, the yearly number of lots for this specific contract and/or the financial possibilities of the customer. Consequently, this lot size can vary as well very significantly. Fig. 4 shows this variation typically within different types of e-scrap. In general, the lot size can vary for 1 lot from about 50 kg up to more than 500 t of material!

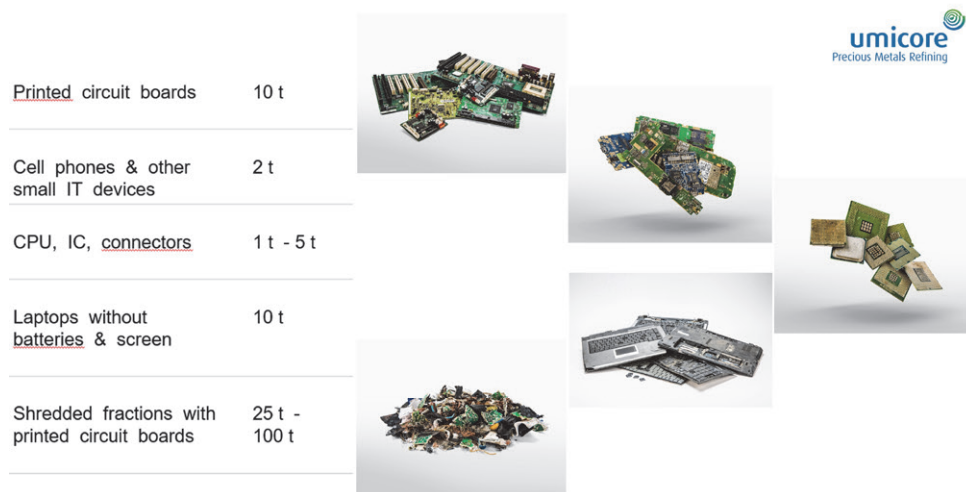

**Figure 4. Variability within incoming E-scrap**

Of course, this lot size equally has its impact on the way the incoming material is handled and shipped. Large lots are often being handled in bulk, and shipped in tipping trucks, containers or even ships, as the plant is located at the river Schelde which connects it to the port of Antwerp. Smaller lots are, in general, mostly packaged in sealed drums, boxes or big bags and are mostly being transported by means of trucks and containers. Due to more and more strict internationally environmental regulations, there is an increasing trend towards packaged goods, also for larger lots, which has of course its influence in the way of handling the material at unloading and may even influence the final way of sampling.

Last but not least, the physical appearance of the incoming materials can be just about anything: dry lumpy material, sludges, filter cakes, metallic scrap, plastic boards, dry powders, ... and anything in between. As we are dealing with precious metals containing materials, a very important feature to determine in most cases for all those materials is the moisture content, ranging all the way from zero to sometimes up to ninety-five percent! Even some types of e-scrap can contain an important amount of water (even ~20%), depending on the way they have been pre-processed before being shipped.

### Sampling at UPMR

As already described above, because of the very diverse and complex incoming materials, sampling and assaying are a key success factor in determining the exact metal content and, as a consequence, the final financial value of each lot. Therefore, UPMR allocates a substantial amount of its operating budget to the sampling and assaying services. At present, about 230 people are working within the sampling department, and about 100 in the laboratory. Yearly, next to the 8000 incoming lots, more than 2000 internal lots (mostly intermediates) are equally being sampled in these facilities. In the laboratory, about 70000 samples are analysed on a yearly base, including all the necessary samples for the follow-up of all the refining and production activities in the plant.

Most of the sampling and assaying processes and technologies are in-house developed, and over the years, TOS also came more and more into the spotlight next to the use of state-of-the art technology. With a mindset on automation, efficiency



and fast throughput, human intervention and sampling risks are minimized. Based mainly on the physical characteristics of the material to be sampled, UPMR has set-up a number of main sampling lines, each of them especially suited for a specific type of material. In this way, dedicated sampling lines have been developed to deal specifically with following type of materials, some of these lines will be described more in detail below:

- Electronic scrap
- Metallic scrap
- Lumpy/rocky materials
- Fine, free flowing materials
- Wet/sticky materials
- Automotive catalysts

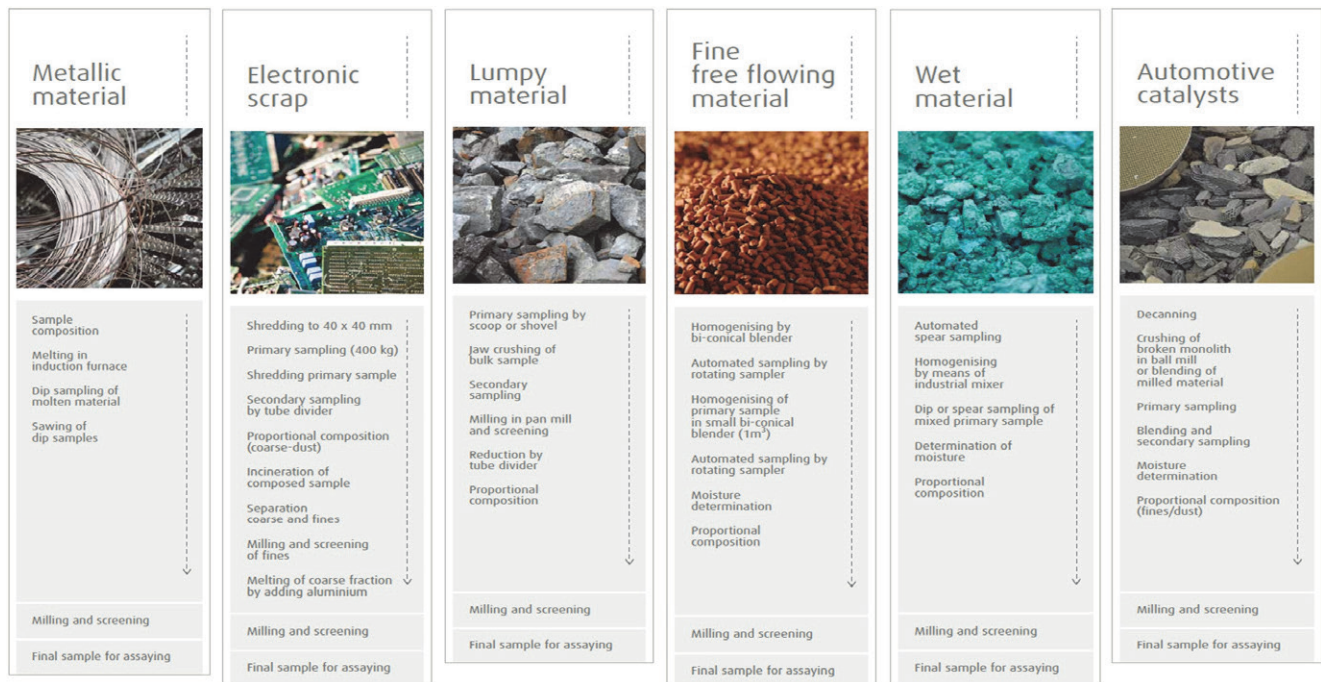

**Figure 5. Dedicated Sampling Lines @UPMR**

### Evolution over time towards TOS principles

In the past 2 decades, the sampling department got a total make-over and further automation was introduced where possible, respecting the TOS principles on the one hand but focusing on greater efficiency and shorter lead times on the other hand. E-scrap nowadays is treated on a big shredder line, including a wind-shifter to remove possible damaging out-of-spec heavy (mostly metallic) pieces, a 2-axis pre-shredder followed by the 4-axis final shredder, both slow rotating shredders to minimize dust formation. The scrap is shredded at a flow rate of up to 10t/h into pieces of 40 mm before going to a 2-stage stream-sampling station, a Vezin-sampler followed by a rotary tube divider, resulting in a primary sample of 400kg. At least 1000 increments are guaranteed in this sampling stage to compose the primary sample. In the early days, e-scrap used to be sort out manually to compose a primary sample which was then further burnt in a furnace for further sample preparation. Both the way of sampling as its environmental impact have been significantly improved by installing these new lines!

Concerning lumpy/rocky materials, the sampling department used to have a jaw crusher with a static (!) sampler until about only 10 years ago. At present, these products are treated now in a 2-stage jaw crusher line, where the particle size is reduced down to 20 mm and where afterwards the primary sample is taken by means of an automated cross-cut stream sampler. Afterwards, this sample is further milled in an automated pan mill-line, mostly in 2-3 stages down to a particle size of < 3 mm. The volume of the sample is reduced after each stage of milling by means of a rotary tube divider. Only 10 years earlier, this sample size reduction still used to be done by means of coning & quartering...



**Figure 6. Pan Mill – Before: Manual screening followed by coning a quartering – After: automated sampling after milling with rotary tube divider**

Another example of this TOS increasing insight has been introduced for the sampling of automotive catalysts. Though a first automation line had been installed, the analysis results on the final samples were not robust enough and also led to quite some complaints. On this old line, the catalyst material was crushed to a size  $< 7$  mm and then sampled by means of a double rotary tube divider into a sample of a few kg, which was further prepared in the final preparation area into the final lab samples. But due to the very special nature of this material, where a very thin high value precious metals containing layer is coated on to a carrier substrate, this material – especially after crushing – is very heterogeneous: especially the dust fraction will contain preferentially substantially more precious metals than the larger particles. For this reason, the size reduction of the catalyst material is nowadays done by means of a ball mill and also milled to a much smaller particle size  $< 1$  mm. The milled material is then sampled by means of a rotary tube divider, and also all dust which is generated before this sampling step is collected separately in a dust filter. It will make a separate fraction of the sample, to be taken into account proportionally. But it was not only the constitutional heterogeneity which had a strong influence on the way of sampling – also the distributional heterogeneity played a significant role in the older days. As it is a recycling business, the feed of the installation can be very diverse: so the amount of precious metals used for the coating of the catalyst converter, can differ very widely from type to type. This resulted often in a somewhat layered primary sample, leading to inaccurate end samples.. So it was also important to introduce a mixing step for the primary sample, which is done by mixing it in a Nauta type vertical cone screw blender before being sampled through a rotary tube divider. The speed of this rotary tube dividers has been also reduced to avoid the possible impact of turbulence on the dust fraction<sup>3</sup>. The dust generated in this sampling step before the sampler is likewise collected separately and will be also taken into account proportionally to the end sample.



**Figure 7. Nauta type vertical cone screw blender for automotive catalysts**

### Other influencing factors

But of course, there is always an economic trade off to be made: resources are - unfortunately - not unlimited! Therefore, the way of sampling is not only determined by the material characteristics, however, there are also other important influencing factors. As explained already before, lot size will be one of these other determining factors. Smaller lots do have mostly a higher value, and will be unloaded directly into the secured sampling department. Mostly they will be sampled completely, for 100%, directly on the most suited sampling line. On the contrary, the larger lots have a lower intrinsic value and will be mostly unloaded outside of the sampling department. For these large volume lots, a primary sample will be taken at first, often in a more manual way, e.g. by means of spear sampling the incoming big bags, or by taking increments with a sample shovel from each unloaded truck. The number of spears/shovels is strongly determined on the intrinsic value of the material: the higher the value of the material, the more increments are being taken. This results more or less in a relative stable amount of primary sample as the lot value is inversely proportional to the lot volume. When these large volume lots do contain more lumpy and/or rocky material the primary sample will be taken during the transfer of the lot with a payloader by collecting half a scoop as a 10 % primary sample at each 5<sup>th</sup> scoop taken during the displacement of the material. All payloaders at UPMR are therefore equipped with a dynamic weighing system to be able to control this process: the drivers are even guided by an onboard IT system which ensures that the driver will perform this way of sampling in an accurate way. On the one hand, this 'payloader' technique is used because it is impossible to sample this type of material in a representative way with a shovel, because of the larger particle size of most of the material, and on the other hand – in such cases – it would be too expensive for these larger lot volumes to crush the material for 100%. This will only be done for high grade, often also heterogeneous materials, or also when this is required for the further refining of the material in the plant. In all of the above described cases, the collected primary samples will afterwards be brought to the sampling department where they then will be further processed on the dedicated sampling lines.

This way of sampling is revealing also another important influencing factor: the cost of sampling. One could also sample the lot for 100% on the dedicated sampling lines, but then it would ask too much time (and so also the overall sampling cost would increase significantly). Another consequence is that in that case the overall lead times for sampling would increase significantly, and would also have an impact on other lots, waiting for sampling. As a company, a trade-off is then to be made to either invest in extra equipment, or to simplify somewhat the way of sampling, depending of course on the financial risks this simplification can imply. Sampling overall lead times need to be under control, as the customer is awaiting the final outcome of the sampling process, the analysis, to get paid for his material delivered.

A nice example of this trade off can be found in the way UPMR organised its e-scrap sampling. For larger lots (mostly >30 t for e-scrap, or > 1 truck load), it is contractually demanded that the material should already be pre-shredded. As this material is mostly low grade material, a primary sample will be taken after the unloading of the material. For very low grade e-scrap, this will be done directly to 400 kg, for more valuable material a 10% primary sample will be collected. Smaller lots (more valuable material, or medium/high grade e-scrap) will be mostly packaged and discharged entirely within the sampling department. These lots will be treated for 100 % on the dedicated sampling lines. On these lines, a primary sample of 400 kg will be collected as well. This means that, regardless of the value of the lot, the size of the primary sample will be always 400 kg. This is a setting the operator needs to adjust, each time when starting a new lot on the sampling line. But as the value of the material is inversely proportional to the lot size, the size of the primary sample will be relatively more important for smaller, high value lots. The reason why the primary sample needs to be 400 kg is because of the standardisation of the following sampling step, where the 400 kg sample is further shredded down to < 7mm. After this shredding step, a secondary sample of 4 kg is then taken by means of a rotary tube divider. This sample will be adjusted proportionally with the during this processing step generated dust. Further preparation of this sample is then done by burning this sample, screening the ashes on 75 $\mu$ . The fines are then blended and distributed, packaged and labelled into a first sample fraction, whereas the coarse fraction is melted in an electrical furnace by adding aluminum. The result of this melt is a kind of brittle, crystalline metallic ingot, which can be grinded and milled down to 180 $\mu$  to result in a second sample fraction for the original e-scrap lot.

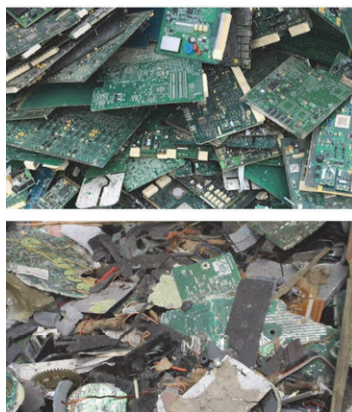

- Shredding to 40 x 40 mm
- Primary sampling (400 kg)
- Shredding Primary sample to 7 x 7 mm
- Secondary sampling by rotary tube divider
- Proportional composition coarse sample with dust
- Incineration of composed sample
- Separation coarse and fines
- Milling and screening of fines (1)
- Melting of coarse fraction by adding Aluminum
- Milling and screening (2)
- Final samples (1) + (2) for assaying



**Figure 8. Sampling of e-scrap @UPMR**

Standardising those secondary sampling steps, has the advantage to be able to have more or less fix lead times for this part of the sampling process of e-scrap. In case everything would be organised based proportionally on the incoming volume of material, too much time would be spent on dealing with the lower grade materials, where the financial risks are in any

case (much) lower than for high grade materials. Another advantage is that quite a lot of the final steps in the final preparation could be automated, and are nowadays performed automatically: a robot distributes the samples from one handling station to another, and at the end the final samples are automatically bagged and labelled. By introducing this automated installation, an increased robustness could be reached: the focus here is on achieving maximal accuracy and repeatability by minimizing the human interaction, and of course on reducing the throughput times.

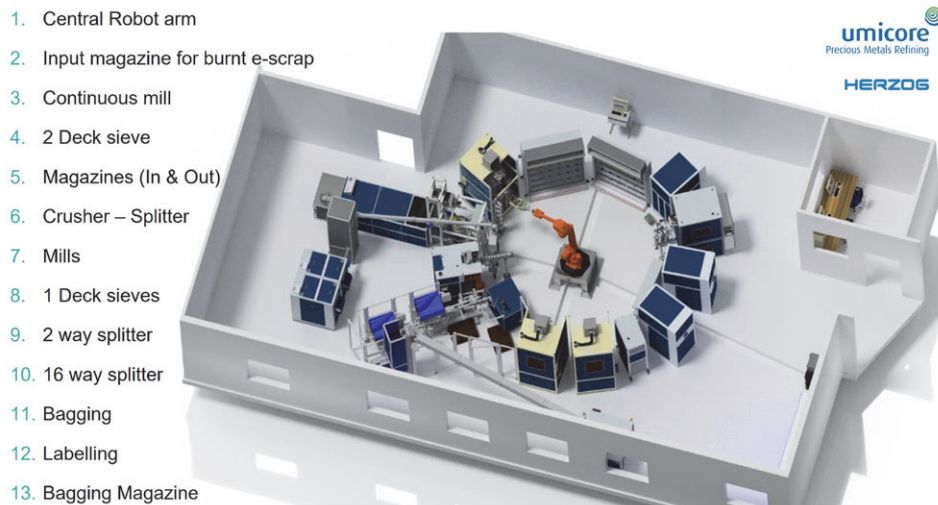

**Figure 9. Automated final preparation @UPMR**

### Modular Sampling Procedures

As the e-scrap example shows, it is not only the material characteristics on themselves which will influence the final way of sampling the material. Of course, they remain the basic foundation for the sampling method to be followed, but there is also a substantial need for increased flexibility, taking into account financial risks and costs and focusing on efficiency and shorter lead times. Therefore, starting from the basic dedicated sampling lines as shown in Fig. 5, UPMR has set-up a modular system of sampling procedures to cope as much as possible with all those sometimes somewhat contradicting needs.

Today, about three hundred different sampling procedures are used. These procedures are, in fact, partial procedures for a certain sampling step (or sub-procedures), mostly related to the installation being used for the specific sampling step and the nature of the material being dealt with. They are subdivided into three major categories:

- Primary sampling procedures (Pxx)
- Secondary sampling procedures (Gyyy)
- Final sample preparation procedures (Fzzzz)

With these three categories of sub-procedures, a number of combinations can be made (if justified, of course), to obtain a specific full procedure (Pxx.Gyyy.Fzzzz) by which means a material will be sampled. On top of that, customer-specific demands can be satisfied by an “à la carte” approach, in which the sampling procedure is – within certain (contractual) limits – developed further in close collaboration with the supplier of a material.

### Sampling Process @UPMR

Keeping all this in mind, the sampling of incoming materials starts in fact already at the moment of the signing of the contract with the customer. Here, packaging requirements are discussed, as certain sampling installations can have constraints on maximum dimensions or weights which can be treated, but also to facilitate the logistics for unloading and safe handling of the materials. Material characteristics will be checked with the sampling experts, and, in general, the most appropriate standard combination of sub-procedures is chosen as the sampling procedure and linked to the contract.

Subsequently, at arrival each incoming lot is controlled and inspected directly after unloading to control if the shipment is complete as indicated by the customer. The next check is on the physical appearance of the material and is mostly documented with pictures to address the following concerns: Is the material really as stated in the contract? Is the initially foreseen sampling procedure suited for the material being delivered? If not, the procedure may be slightly adapted (often in close collaboration with the customer or his representative on site). In other cases, a non-conformity report will be created, pointing out all the issues to the customer and proposing solutions. Meanwhile, the material will be blocked for sampling and further treatment until an agreement has been reached with the customer on how to proceed.

Once the material has been inspected and the sampling procedure has been validated, the material is released for the actual sampling. A primary sample is taken, which is then further treated on one of the many sampling lines. All relevant weighing information is registered. During this treatment, samples are generated, collected and brought to the final preparation area. Samples are then further prepared, packed and labelled and will be sent to UPMR’s laboratory (and the customer) for detailed analysis. A weighing and sampling report is made up, containing all relevant sampling information about the lot at hand, including: net wet weight delivered, moisture content, description and composition of the different samples/sample fractions.

## Quality assurance

Due to the multitude of products and procedures on the one hand, and the financial risks on the other hand, it is obvious that the quality of the sampling process is crucial for the success and continuity of the company. The overall quality is therefore continuously monitored and supervised, through internal and external, independent assessments, often also in close collaboration with the customers.

As explained above, the first monitoring step takes place at the start of the contract, where the material characteristics are discussed as well as the logistical preconditions for the material to be sent. At arrival, the material is then checked in detail to confirm ultimately the exact way of sampling, sometimes after having made the necessary adjustments in agreement with the customer. For some type of products (e.g. e-scrap), a reserve (primary) sample will always be put aside until the whole sampling process has ended, or sometimes even until final analysis is known. This is done likewise for materials, where financial risks are estimated to be high, i.e. mostly for very heterogeneous materials. These reserve samples can sometimes be used already during the first sampling process, when one discovers further in the sampling process that the chosen way of sampling is not the best way to obtain an optimal result. The reserve sample will then be started up, and can – in agreement with the customer - even be sampled according to an adjusted sampling procedure which fits better for the material at hand. Also in case of a mistake or any other problem somewhere in the sampling process, the reserve sample will function as a kind of insurance for both parties, customer and refiner.

## Monitoring analysis results

Samples are sent to the laboratory and to the customer for analysis. These analysis results are monitored for each type of product and contract, and where possible, compared with historic data and/or pre-shipment analysis coming from the customer. If anything unusual is detected, the laboratory will question this to the sampling department. In some cases, it can also be the customer who is questioning the final analysis results. In the sampling department, all the necessary information to these questions is then gathered and examined further in detail. In most cases, the answer can be found in deviating material characteristics which have been detected and documented inside of the sampling department. In some cases it is not directly clear, what the reason of deviation could be. In such cases, and when there is still a reserve sample available, this will then also be sampled to recheck the final analysis results. Yearly there are more than 150 of these questions to be examined, resulting in about 10% of extra rechecks to be done. In some cases, the customer will not agree with the final analysis results, and can request – under certain conditions – for an official resampling of the material (starting from the reserve primary sample). In such cases, further agreements are made upfront in detail with the customer how to cope with the final result after the resampling.

## Quality control programme

Next to these rechecks “on demand”, the sampling department carries out on a yearly base an intensive quality control programme. In this programme, about 50 lots are sampled in double to follow up the performance on the major sampling lines. Where possible, the total lot will be resampled a second time, after the official sampling. For e-scrap, the reserve 400 kg primary sample will be further sampled to compare the analysis results with the first official sampling. All results of the first and second sampling are then compared with each other. The differences should be between certain limits, depending on the type of material and the sampling procedure that was followed.

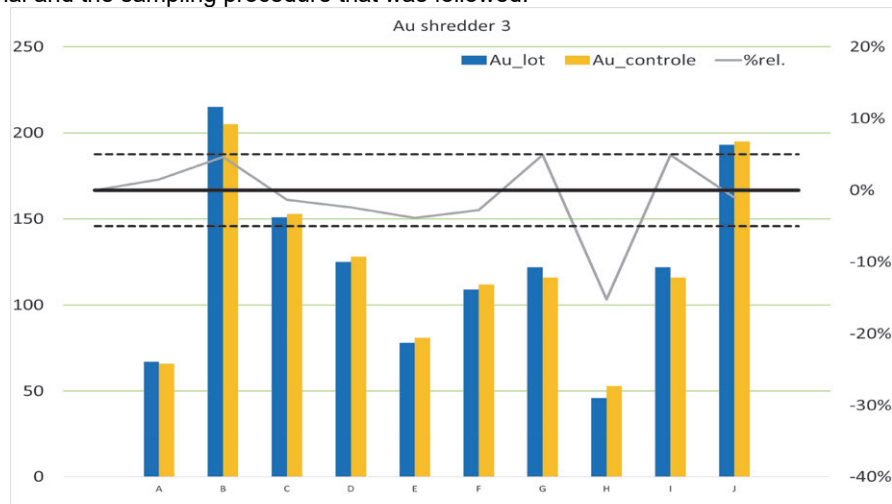

**Figure 10. Quality Control Programme 2021 Shredder 3 – Au result**

This type of control is also used when new equipment is installed, or new sampling procedures are introduced. Lots will be sampled on a well-known sampling line, or according to a well-known sampling procedure, and will then be 100% resampled on the new sampling line, or according to the new procedure proposed. After final analysis, the results of the lots sampled on the new sampling line or following the new sampling procedure are compared with the results of the sampling the same lots on the well-known sampling line or according to the well-known sampling procedure. The results for the new line or method should fall within the same accuracy ranges as the results after sampling on the well-known lines or following the usual sampling procedure. Fig. 11 shows the test results for milled automotive catalysts being sampled according to a new continuous way vs. the well-known batch-wise approach.

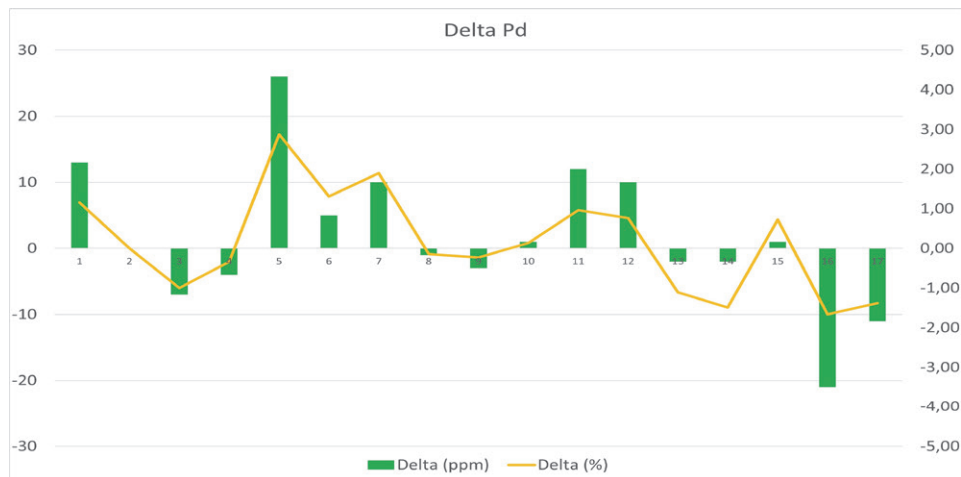

**Figure 11. Comparison continuous sampling vs. batchwise sampling of milled automotive catalysts – Pd results**

### Inventory process

Sampling also plays a crucial role in the plant's inventory process. Due to the large amount of precious metals on site, it is very important that the stock at inventory time is determined in an accurate way. Not only do weights need to be registered correctly, but also moisture content and composition of the materials (often intermediates) need to be determined in a representative way. At UPMR, a detailed inventory is carried out twice a year.

In this exercise the plant checks the evolution of the stocks of metals over a 6 months period: the metals stock from 6 months ago, increased by the incoming metals over 6 months and reduced by the outgoing metals in the same 6 months should be equal to the metals stock actually on site. At these moments, the sampling department needs to sample > 300 lots of intermediate materials to determine their metals content. The final outcome of this exercise needs of course to be between narrow ranges, depending on the type of metal, to ensure the financial health of the company.

### Some special cases...

Despite the fact everything seems to be prepared upfront in detail – at least on paper, reality however often shows a large discrepancy from what was promised before. This can really be about anything you could imagine, which is illustrated by underneath cases. As you will see, in those cases “nothing seems to be what it was expected for”...

#### Filter cake

During the check of the physical appearance, typically a few packages per lot are opened, to verify the material inside. For this shipment, 9 containers with 214 pallets each containing 4 drums, 18 lots had to be sampled. After opening some of the drums, it appeared that some of these drums did not only contain filter cake, but were covered under a layer of white sand. Apparently (after questioning the customer), for transport reasons this material needed to be covered with this sand. Of course, this was never discussed before...

The normal foreseen sampling procedure for this filter cake was: spear sampling each drum five times, and then mixing the primary sample in the mixing installation. A trial for 100% mixing was done on 1 lot, but it appeared to be very difficult to nicely homogenise the sand together with the filter cake. Next to this fact, also the throughput time would be very high to treat all this material for 100%. It was then decided to screen the whole shipment by means of a vibrating 10 mm screen. The oversize material was collected per lot into big bags, and could then be spear sampled; the undersize was treated as 1 extra single lot and was manually primarily sampled during transfer by means of a sampling shovel.



**Figure 12. Filter Cake with white sand – Mixing result**

### Ag-Au concentrate

For this shipment, 7 containers each containing 22 big bags, had to be spear sampled as 1 lot, 5 spears per big bag. But, the material was to the large extent hardened, and couldn't be spear sampled at all. Therefore, an alternative sampling method imposed itself. Due to the nature of the product, unloading of the big bags needed to be performed by means of a grab crane. The material needed to be broken into pieces and more or less pulverised by the crane before further manual primary sampling was possible by means of a sampling shovel. Moisture samples were separately collected per container, and further reduced through grid sampling, moisture content was subsequently determined in double for each container. The primary sample was afterwards treated in the pan mill for further sample preparation. All the extra costs for these activities were of course charged to the customer.



**Figure 13. Ag-Au Concentrate – Discharge with crane**

### Ashes

This material is coming very regularly from another refining plant, and is also sampled at their premises. But, when the final outcome of the analysis was compared, there were from time to time large discrepancies between the analysis based on the sampling Hoboken compared with the initial analysis found at the other plant. So, an extensive investigation was started, both at the supplier's side as at the refiner's side.

The material was prepared by the supplier to a particle size  $< 300\mu$ . By auditing each other's processes, it was soon detected that the primary sampling at the supplier's side was done by means of a screw sampler in the outgoing stream of a blender! So this sampler was only covering part of the outgoing stream of material after blending, which conflicts with the Fundamental Sampling Principle (FSP = "All potential increments of a lot shall have identical non-zero probability and practical possibility to end up as the physically extracted increment"<sup>2,3,4</sup>). So, especially with heterogeneous materials, this was clearly the reason behind the sometimes widely diverging analysis results.

But as it was an extensive exercise, also some extra reserve samples were taken during sampling at UPMR, and analysed accordingly. For some materials, however, a far larger spread in results was found also between these similar samples as normal for the sampling line used. That's why the final samples were screened on  $300\mu$ , before being further prepared to laboratory samples. And yes, it appeared that more than 2% of the material was a  $>300\mu$  coarse metallic fraction, which contained 5 times more precious metals as the fines fraction! So this material was definitely not the same as in most other

cases. After further investigation at the supplier's side, this material turned up to be ashes containing also crushed refractory brick material. So, in this case also the constitutional heterogeneity of the material played an important role for some lots: to cope with this phenomenon, the final sampling stage of this lot has been adapted and includes now a grinding step where the total sample needs to be grinded  $< 300\mu$  before being further reduced.

Ashes - Screw sampler



Ashes - Fines



Coarse fraction



**Figure 14. Screw sampler – Coarse fraction within ashes**

## Conclusion

Sampling in a precious metals refining company can be very diversified (and challenging!) as a consequence of the very different and often complex materials that are dealt with. As sampling is a key success factor for the sustainable recycling of precious metals, it deserves significant attention. It is however not only influenced by TOS, there is always an economic trade-off to be made to which extent these rules prevail to be able to reduce on the one hand the financial risks for both the customer as well as the refiner, and on the other hand to guarantee high efficiency and short lead times. UPMR's vision in this matter illustrates this: Master Complexity, Foster Flexibility and Ensure Reliability<sup>1</sup>.

## ORCID iDs

Bert Pauels: <https://orcid.org/0000-0002-2815-3688>

## References

1. F. Vanbellen & M. Chintinne, "Extreme makeover: UPMR's Hoboken plant", *Proceedings of EMC 2007 – Volume 1, GDMB*, pp. 371-380 (2007). ISBN 978-3-940276-04-9
2. K.H. Esbensen, "Introduction to the Theory and Practice of Sampling", *IM Publications Open*, (2020). <https://doi.org/10.1255/978-1-906715-29-8>
3. F.F. Pitard, "The Theory of Sampling and Sampling Practice, Third Edition", *CRC Press*, (2019). <https://doi.org/10.1201/9781351105934>
4. DS 3077, "Representative sampling—Horizontal Standard", *Danish Standards* (2013). <http://www.ds.dk>





## Challenges of sampling grain for mycotoxin analysis

S.A. Tittlemier<sup>a</sup>

<sup>a</sup>Grain Research Laboratory, Canadian Grain Commission, Government of Canada, 1404-303 Main St, Winnipeg, Manitoba, R3N 1W1, Canada. E-mail: Sheryl.tittlemier@grainscanada.gc.ca  
DOI: [to be added by publishers]

**Abstract:** During growth and post-harvest storage, fungi can infect grain and produce secondary metabolites known as “mycotoxins”. Some mycotoxins are regulated due to their potential hazardous health effects. Thusly, analysis of bulk grain consignments for mycotoxins is common in the grain trade. The heterogeneity of bulk grain with respect to deoxynivalenol (DON) and ochratoxin A (OTA), two regulated mycotoxins, was investigated. Variation of concentrations amongst individual wheat kernels was assessed, along with the variation within sub-samples and test portions produced from 10 kg laboratory samples, and amongst 500 t increments sampled during loading of bulk shipments (4,600 to 55,000 t). Concentrations in individual kernels ranged from < 0.02 to 583 mg/kg for OTA and < 0.3 to 414 mg/kg for DON. Analysis of the distribution of concentrations was limited due to the difference between the sample sets available for use; one was naturally infected (DON) and the other was inoculated and incubated under laboratory conditions (OTA). Bulk shipments were sampled during loading using a Canadian Grain Commission-approved automated cross-stream diverter-type sampler and in-line divider. Increments were combined, and 10 kg laboratory samples were prepared from the resulting composite using a Boerner divider, comminuted using a rotor beater mill, and sub-sampled using rotary sample division to produce representative sub-samples and test portions. Concentrations of OTA in the 500 t increment samples varied from < 0.25 to 22.9 µg/kg; DON varied from < 0.05 to 0.67 mg/kg. Within shipments, the OTA concentrations varied more amongst increments than did DON. The coefficients of variation for OTA ranged from 42 to 95% which were 2-4x greater than for DON. The results illustrate heterogeneity of bulk wheat relevant to international trade and regulated mycotoxins. Differences observed for DON and OTA also reflect how biological differences in mycotoxin production contributes to the challenges faced in analysing bulk whole grain for mycotoxins.

## Introduction

Mycotoxins are secondary metabolites produced by various fungi in a variety of commodities and foods. These compounds are not directly involved in the basic functioning of fungi, but some appear to play a “chemical offense” role and increase the susceptibility of the host organism to further fungal infection<sup>1</sup>. As suggested by their name, mycotoxins can cause toxic effects when consumed. The potential harmful effects of mycotoxins vary and a range of both acute and chronic effects ranging from emesis to immunosuppression have been reported<sup>2</sup>. Two globally relevant mycotoxins often found in cereal grains such as wheat are deoxynivalenol (DON) and ochratoxin A (OTA).

Both DON and OTA are currently regulated in wheat due to their potential hazardous effects and relative importance of wheat in staple foods of many populations. Existing maximum limits for DON in wheat range from 1.0 to 2 mg/kg<sup>3,4</sup>; most maximum limits for OTA in wheat are 5 µg/kg<sup>3,5</sup>.

Routine testing of wheat for DON and OTA is often employed to ensure compliance with regulations during trade. It is particularly challenging to relate an analytical test result for DON or OTA from a sample back to a bulk volume of wheat because of these mycotoxins' uneven distributions in bulk grain lots. Studies have demonstrated this variability of DON and OTA concentrations within truckloads<sup>6,7</sup> and stored grain<sup>8</sup>.

The heterogeneity of grain with respect to DON and OTA is influenced by a variety of factors at different stages of grain production. To begin, the occurrence of these mycotoxins is variable due to such factors as precipitation and temperature during the growing season, storage time and conditions after harvest, as well agronomic factors such as selection of cultivars, tillage, and use of fungicides, which affect fungal production. The conditions that promote fungal growth and mycotoxin production vary amongst fungi. For example, the growth of *Fusarium graminearum* and subsequent production of DON is promoted by cool and wet conditions around the time of flowering. However, OTA is produced during storage of grain when *Penicillium verrucosum* flourishes and outcompetes other microorganisms.

After harvest and storage, there are other processes that can affect the presence and heterogeneity of mycotoxins in grain. In the bulk handling systems for cereal grains in North America, grain can be cleaned by using optical sorters or separators based on size or density to remove infected and contaminated kernels. Grain from various sources is also combined to produce the high volumes needed for bulk shipments. And during the transport of grain from farms to primary and terminal elevators, as well as to processing facilities, bulk volumes experience shaking which can lead to stratification of the grain.

The heterogeneity of grain with respect to mycotoxins results in measurement variability, and therefore, uncertainty in mycotoxin testing results and how they relate back to a consignment of grain. With this uncertainty comes business risk, and in the worst cases, health risks.

This paper outlines the challenges with analysing grain for mycotoxins, specifically as it pertains to sampling and processing samples and their associated variance. This paper also presents some of our research performed to characterize the challenges with analysing grain for mycotoxins. This paper presents work on the characterization of the wheat kernel-to-kernel variation of two mycotoxins relevant to the international grain trade (OTA and DON), and the characterization of the heterogeneity of large wheat lots with respect to OTA and DON.

## Methods and materials

### Kernel-to-kernel variability of OTA and DON

Existing research activities were leveraged to obtain wheat containing DON or OTA.

Due to the low frequency of occurrence of OTA during grain monitoring, wheat was inoculated and incubated to produce samples of contaminated grain. *P. verrucosum*-infected wheat kernels were prepared in the laboratory as a source of OTA test material. Test tubes were filled with 100 kernels of wheat at 20% moisture content (m/m) and then autoclaved to inactivate any potentially interfering or competing organisms. A kernel of wheat inoculated with an isolate of *P. verrucosum* known to be a prolific OTA-producer was placed on top of the sterilized kernels. The test tubes were placed inside an incubator along with controls that did not contain *P. verrucosum*-inoculated kernels.

At each sampling time point, an inoculated and a control tube were removed from the incubator. Individual kernels from the inoculated test tube were analysed for OTA. Initially, sampling occurred every 7 days. After 19 sampling points as the fungal spread within the tubes (assessed visually) slowed, sampling frequency was adjusted to every 14 days, ending after 413 days.

Each kernel was weighed, crushed, and placed into a 15 mL glass culture tube for extraction and analysis by liquid chromatography with fluorescence detection using a modification of Tittlemier et al.<sup>9</sup> to increase the ratio of extraction solvent from 5:1 (v/m) to 50:1 (v/m). Blank wheat matrix and wheat certified reference material was analysed with samples from each time point to monitor method performance over the course of the study.

Kernels selected from harvest samples of western Canadian wheat, as well as durum, which were visually inspected by Canadian Grain Commission (CGC) inspectors and categorized as having no, mild, or severe *Fusarium* damage<sup>10</sup> were obtained from another research project. Kernels were individually weighed, enveloped in white paper, and then crushed by a hammer. Each crushed kernel was quantitatively transferred to a glass vial and extracted and analysed for DON by gas chromatography with mass spectrometry as described in Gräfenhan et al.<sup>11</sup> Blank wheat matrix and wheat certified reference material was analysed with samples from each batch to monitor method performance over the course of the study.

### Variability of OTA and DON within large lots

Three lots of bulk wheat were sampled as the grain was being loaded onto vessels. Sampling of the wheat during loading was performed by CGC inspectors according to standardized procedures using CGC-approved automated cross-stream sample diverters and dividers<sup>12</sup>. A general schematic of the sampling process used to obtain increments, sub-lot composites, and cargo composites is shown in Figure 1. Increment samples were taken from the moving grain flow by cross-stream sample diverters at a constant interval during the entire loading of the lots. The increment samples taken from each 500 t portion of grain flow were then combined into a 500 t sub-lot composite sample. A Boerner divider (Seedburo Equipment Company) was used to divide the 500 t sub-lot composite sample into a 2 kg laboratory sample as well as a separate portion that was subsequently used to prepare the cargo composite.

The portions of all 500 t sub-lot composite samples obtained during the loading of an entire lot were combined to form the cargo composite. A Boerner divider was used to divide the cargo composite into a 10 kg laboratory sample.

The 10 kg cargo composite laboratory samples of whole grain were processed according to the method described in Tittlemier et al.<sup>13</sup> The 2 kg sub-lot composite laboratory samples of whole grain were processed in a similar fashion. Comminution was performed on the Retsch rotor beater mill, and the entire mass of ground grain was homogenized and divided into 10 x 200 g portions on the RSD. After the first division into 10 x 200 g, all 10 portions were recombined in the RSD hopper and divided into 10 x 200 g again. Five of the 200 g portions were randomly selected and combined, and the 1 kg combined sample was then homogenized and divided on the RSD into 10 test portions of 100 g of ground grain.

Samples were analysed for OTA and DON using validated and published methods<sup>9,11</sup>.

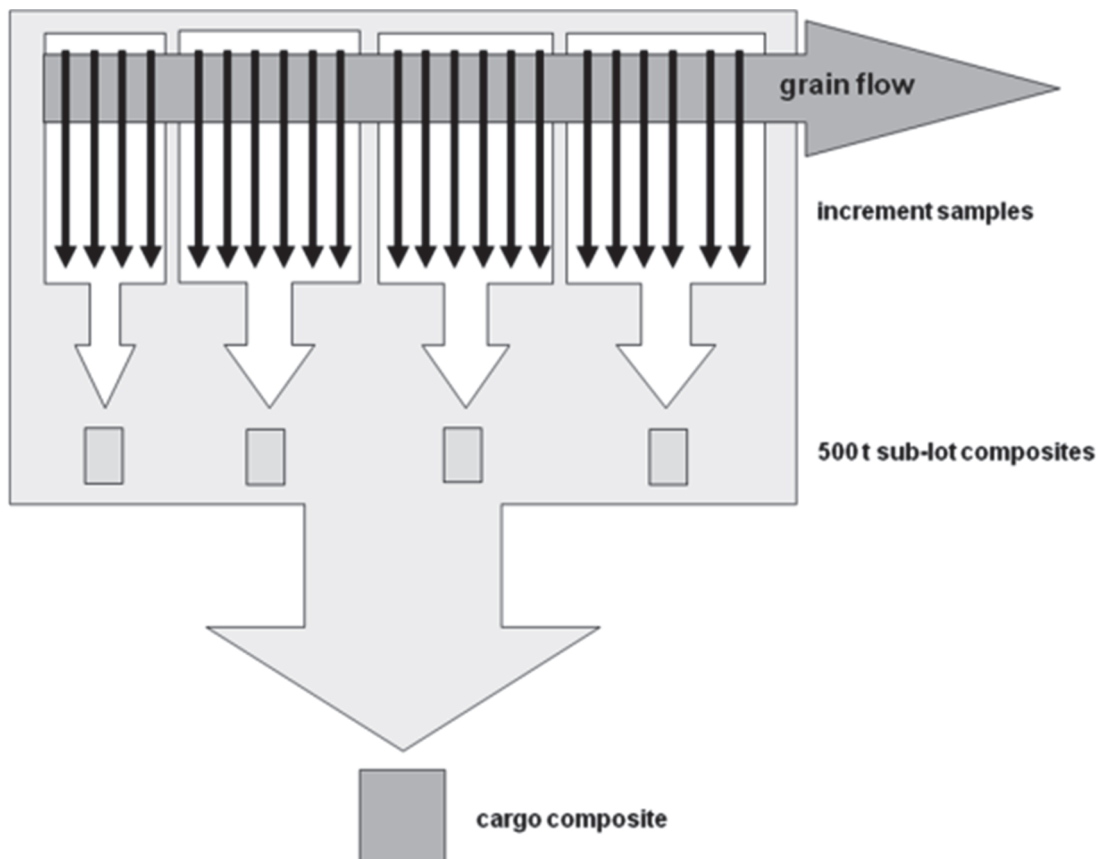

**Figure 1. Schematic of sampling process used to obtain increments, sub-lot composites, and cargo composites.**

## Results and discussion

### Kernel-to-kernel variability of OTA and DON

Concentrations of DON in individual kernels with no, mild, or severe *Fusarium* damage ranged from less than the limit of quantitation (0.3 mg/kg) to 414 mg/kg. As expected, DON was more frequently detected, and at higher concentrations, in kernels characterized as having severe *Fusarium* damage (Figure 2). Concentrations of OTA in individual kernels ( $n=3497$ ) sampled and analysed from all time points ranged from less than the limit of quantitation (0.02 mg/kg) to 583 mg/kg.

Analysis of the distribution of concentrations and comparison between the two mycotoxins was limited due to the nature of the sample sets available for use; one was naturally infected kernels (DON) and the other was inoculated and incubated under laboratory conditions (OTA). The original aims of both sample sets were not related to determining the distribution of the two mycotoxins amongst kernels. However these sample sets still provide valuable information on the compositional heterogeneity of grain with respect to OTA and DON. Data on this type of compositional heterogeneity are very limited.

Concentration ranges in the individual kernel sample sets spanned over 4 orders of magnitude for OTA and differed with incubation time. For example, kernels with measurable OTA appeared after 28 days. At this time point, only 4% of kernels contained measurable OTA. After 49 and 91 days, the proportion of kernels containing measurable OTA increased to 66% and 93%, respectively. Median kernel OTA concentrations were 0.26 mg/kg and 4.4 mg/kg after 49 and 91 days, respectively. Figure 3 provides a snapshot of kernel OTA concentration distribution at two time points.

This sample set of kernels is very comprehensive as it covers a range of storage times and would include kernels at the initial stages of infection and OTA production, to highly infected and contaminated kernels. As a whole, this sample set is likely a good representation for “hot spots” of OTA contamination in bulk grain at later steps of the grain handling chain. At these later steps, bulk lots are composites of grain from many sources that have been subject to potentially many different storage conditions.

Concentration ranges in the individual kernel sample sets spanned over 3 orders of magnitude for DON. Range widths depended both upon grain class and degree of *Fusarium* damage. As illustrated in Figure 2, kernels classified as having more severe *Fusarium* damage contained DON more frequently and at higher concentrations. DON concentrations ranged from <0.3 to 55 mg/kg for wheat kernels showing no damage, from <0.3 to 199 mg/kg for kernels showing mild damage, and <0.3 to 414 mg/kg for kernels showing severe damage. Wheat kernels also contained DON more frequently, and in a wider range, than durum kernels. For kernels classified as having severe *Fusarium* damage, 29% of durum kernels contained measurable DON (maximum of 199 mg/kg) as compared to 74% of wheat kernels (maximum of 414 mg/kg).

The distributions provided in Figure 2 reflect DON concentrations in a sub-set of kernels classified with a certain level of *Fusarium* damage; they do not reflect the distribution of DON in wheat. The kernels selected for study were purposefully chosen to provide approximately equal numbers of kernels displaying no, mild, or severe visual symptoms of *Fusarium* infection. However, the sample set still provides useful information on factors that will contribute to the variance of DON measurements in wheat.

DON concentrations were significantly negatively correlated with kernel mass (Pearson Product Moment Correlation,  $r^2 = 0.234$ ,  $p < 0.00034$ ). No association between kernel mass and OTA concentration was observed. As mass decreased, DON concentration increased. The more severely damaged kernels were shrivelled or shrunken and contained higher DON. The ratio of mean mass of severely damaged kernels to those with no damage was 0.65.

The correlation between kernel mass and DON concentration introduces a challenge for proper sampling of bulk wheat for mycotoxin analysis. As bulk wheat is moved along the grain handling chain it will stratify, and the shrunken and shrivelled severely damaged kernels will not be evenly distributed throughout the bulk volume. This will result in the stratification of DON within the bulk volume as well. Such stratification was noted for a truckload of wheat<sup>6</sup> as well as multiple truckloads of barley<sup>14</sup>. Based on the lack of association between kernel mass and OTA concentrations, such stratification is not expected for OTA.

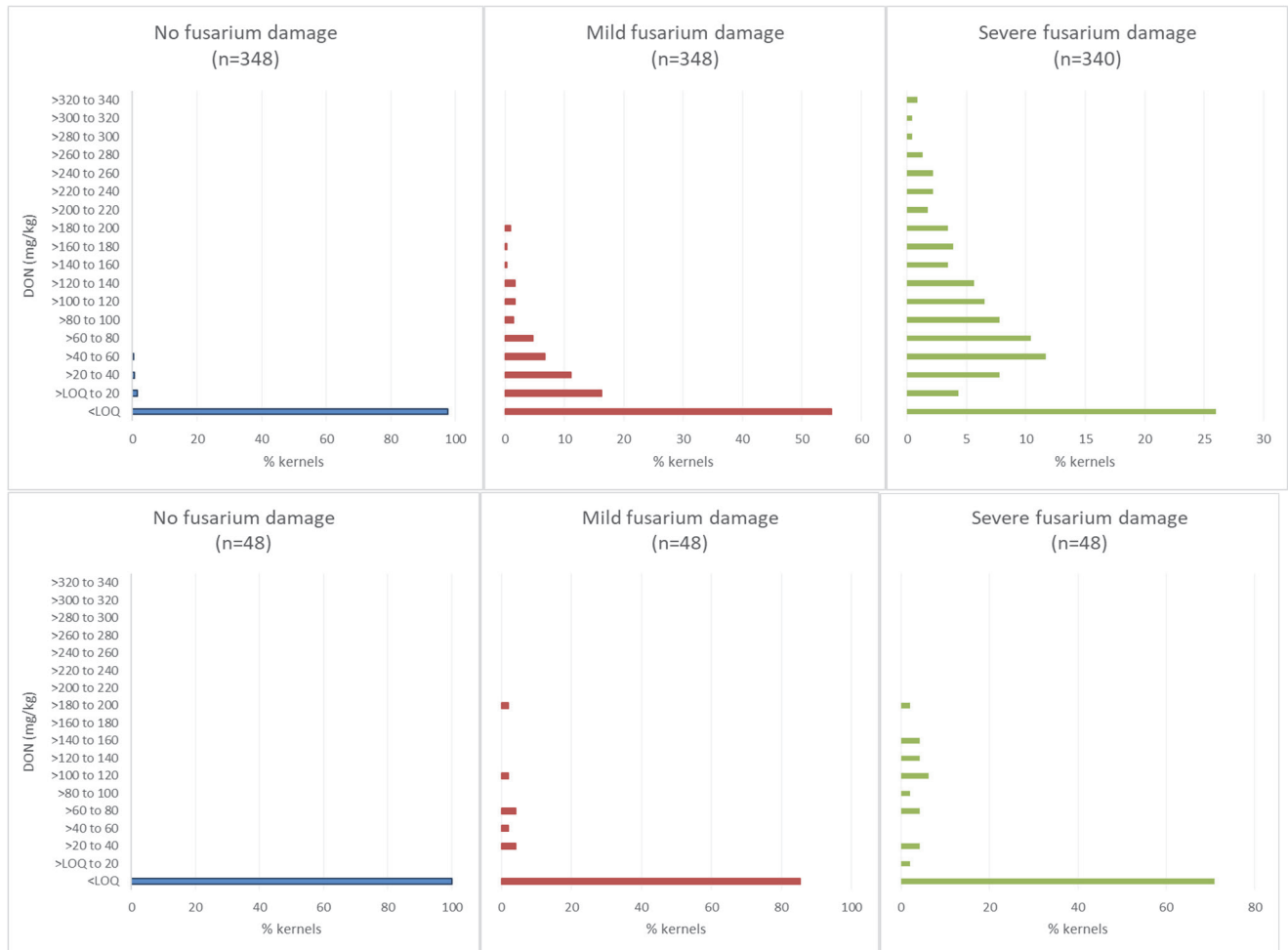

**Figure 2. Distribution of DON concentrations in naturally infected individual wheat (top row) and durum (bottom row) kernels visually assessed with various degrees of Fusarium damage.**

These experimental results demonstrate that the compositional heterogeneity of grain with respect to OTA and DON depends on a number of factors, and these factors are not constant. For OTA, the length of time wheat has been in storage under the particular conditions needed for OTA production will be a main factor affecting compositional heterogeneity. Annual cycles of OTA concentrations peaking in the late summer and early fall, after a winter of storage reflect the impact of time on OTA occurrence<sup>9</sup>. For DON, the degree of Fusarium damage, and therefore DON, present in a volume of grain will depend on several interrelated factors including growing location-related precipitation and temperature<sup>15</sup>. Growing location will also impact the microbiome, which influences the potential of infection and DON production, as certain species or strains produce less, or even no, DON<sup>16</sup>. These factors can change substantially amongst years. For example, the percentage of samples containing enough Fusarium damaged kernels to be downgraded in quality according to Canadian tolerances varied from less than 5% in 2003 to approximately 60% in 2016, the most previous outbreak of Fusarium head blight in western Canada<sup>17</sup>. Therefore as wheat from multiple growing locations and years is combined into lots at different times, each lot will have its own compositional heterogeneity.

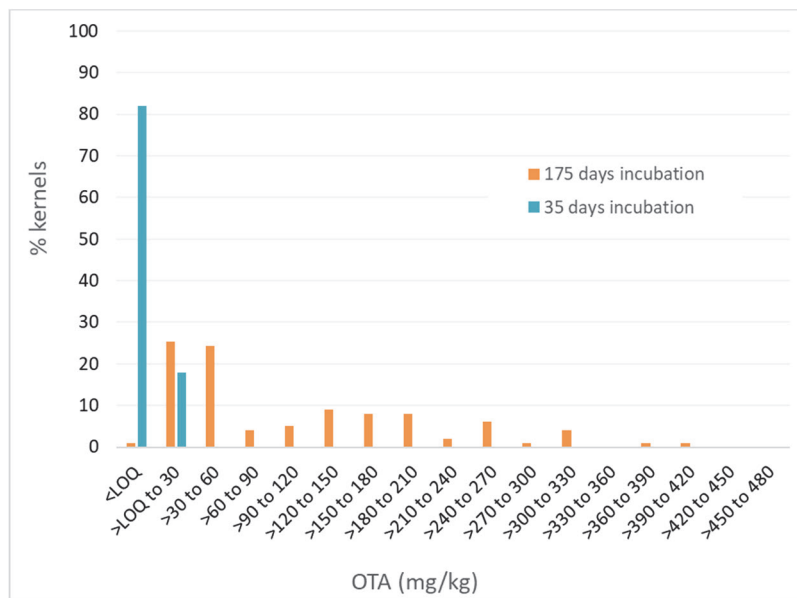

**Figure 3. Distribution of OTA concentrations in individual wheat kernels inoculated with *P. verrucosum*.**

#### Variability of OTA and DON within large lots

A summary of the OTA and DON results from the analysis of the 500 t sub-lot composites for each of the three bulk wheat vessel shipments is provided in Table 1. Figure 4 illustrates the sequential OTA and DON concentrations for the individual 500 t sub-lot composites prepared during loading of each of the three bulk wheat lots. Visual inspection of the plots suggests that there is minimal spatial dependence of OTA concentrations amongst 500 t sub-lots during loading, but that may not be the case with DON.

**Table 1. Summary of OTA and DON results from the analysis of 500 t sub-lots of bulk wheat.**

Bulk lot	Cargo A	Cargo B	Cargo G
Bulk lot mass (t)	28300	33000	55000
n 500 t sub-lots	57	66	110
n sub-lots > OTA LOQ	20	57	108
Sub-lot mean $\pm$ standard deviation OTA ( $\mu\text{g}/\text{kg}$ )	$1.1 \pm 0.5$	$3.2 \pm 2.2$	$4.4 \pm 3.3$
Sub-lot OTA range ( $\mu\text{g}/\text{kg}$ )	<0.05 - 2.58	<0.05 - 9.67	<0.05 - 22.9
n sub-lots > DON LOQ	57	63	55
Sub-lot mean $\pm$ standard deviation DON (mg/kg)	$0.2 \pm 0.1$	$0.15 \pm 0.07$	$0.12 \pm 0.05$
Sub-lot DON range (mg/kg)	0.03 – 0.47	<0.05 – 0.35	0.05 – 0.31

The experimental variograms shown in Figure 5 were used to further explore the spatio-temporal variability of DON and OTA in the three bulk wheat shipments. For OTA in all three cargos and DON in cargo B, no correlation amongst sub-lot composites is apparent. However, the variogram for DON in cargo A suggests a prominent trend in concentration. This is reflected in the line plot in Figure 4 showing a decrease in concentration over the first 47 sub-lots. The variogram for DON in cargo G suggests a cyclical aspect as well as a broader trend in concentrations; the variogram is again a reflection of the observed concentration line plots in Figure 5.

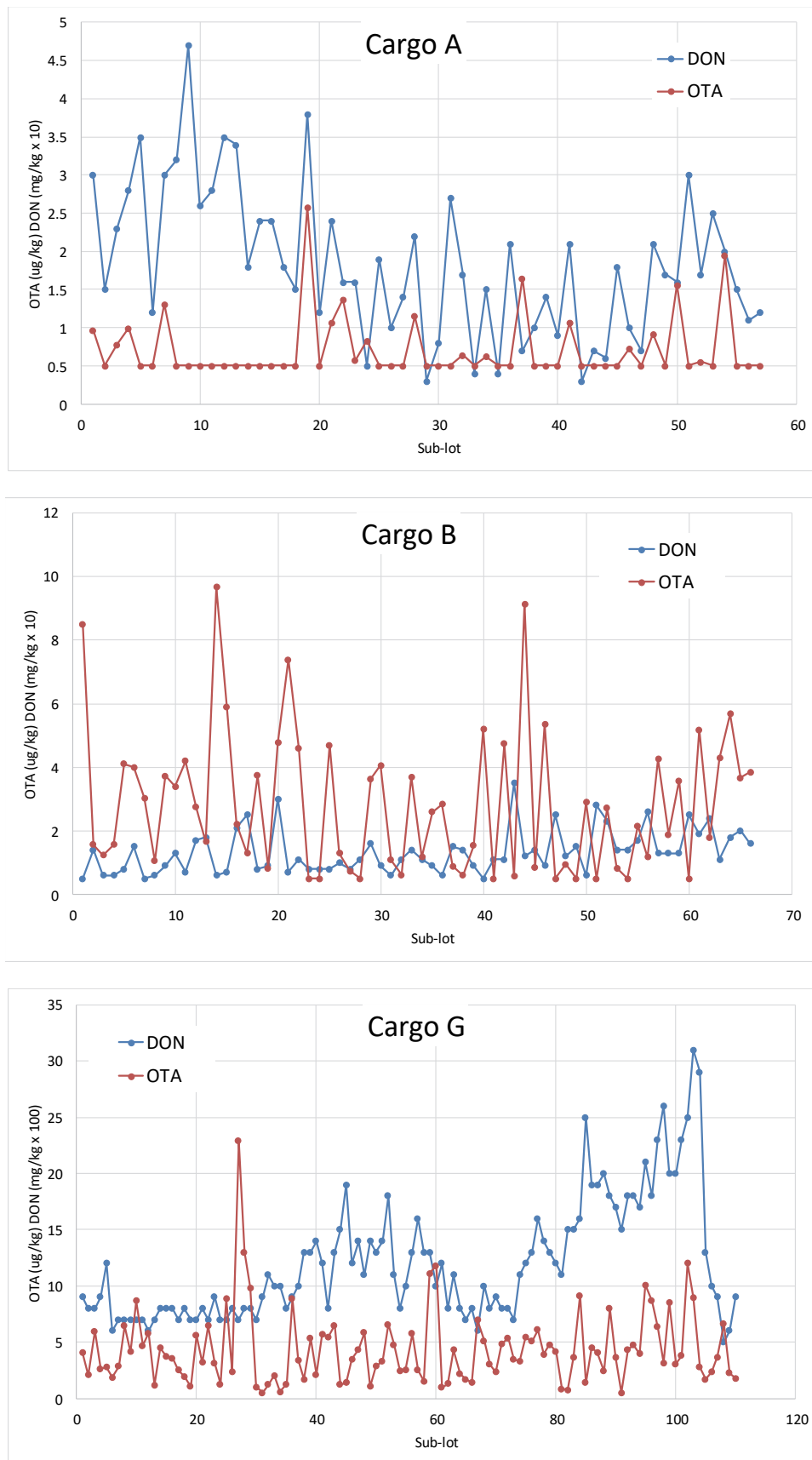

**Figure 4. OTA and DON in 500 t sub-lot composites of bulk wheat lots. Results below the limits of quantitation were set equal to the limits (OTA 0.5 µg/kg; DON 0.05 mg/kg).**

In particular for DON, the differences observed in the variograms from the three cargos indicate that at the end of the grain handling chain, the spatial structure of bulk volumes of wheat with respect to *Fusarium* damage and DON concentration can take many forms. However, these spatial structures are but a snapshot in time during loading of the bulk volumes. As the grain enters the cargo holds it will flow; it will shift during transit, and will also flow and alter its spatial structure during the process of unloading at destination. As is well-known from the experiences within the Theory of Sampling (TOS) realm, heterogeneity is indeed a transient phenomenon, ever changing when lots are agitated.

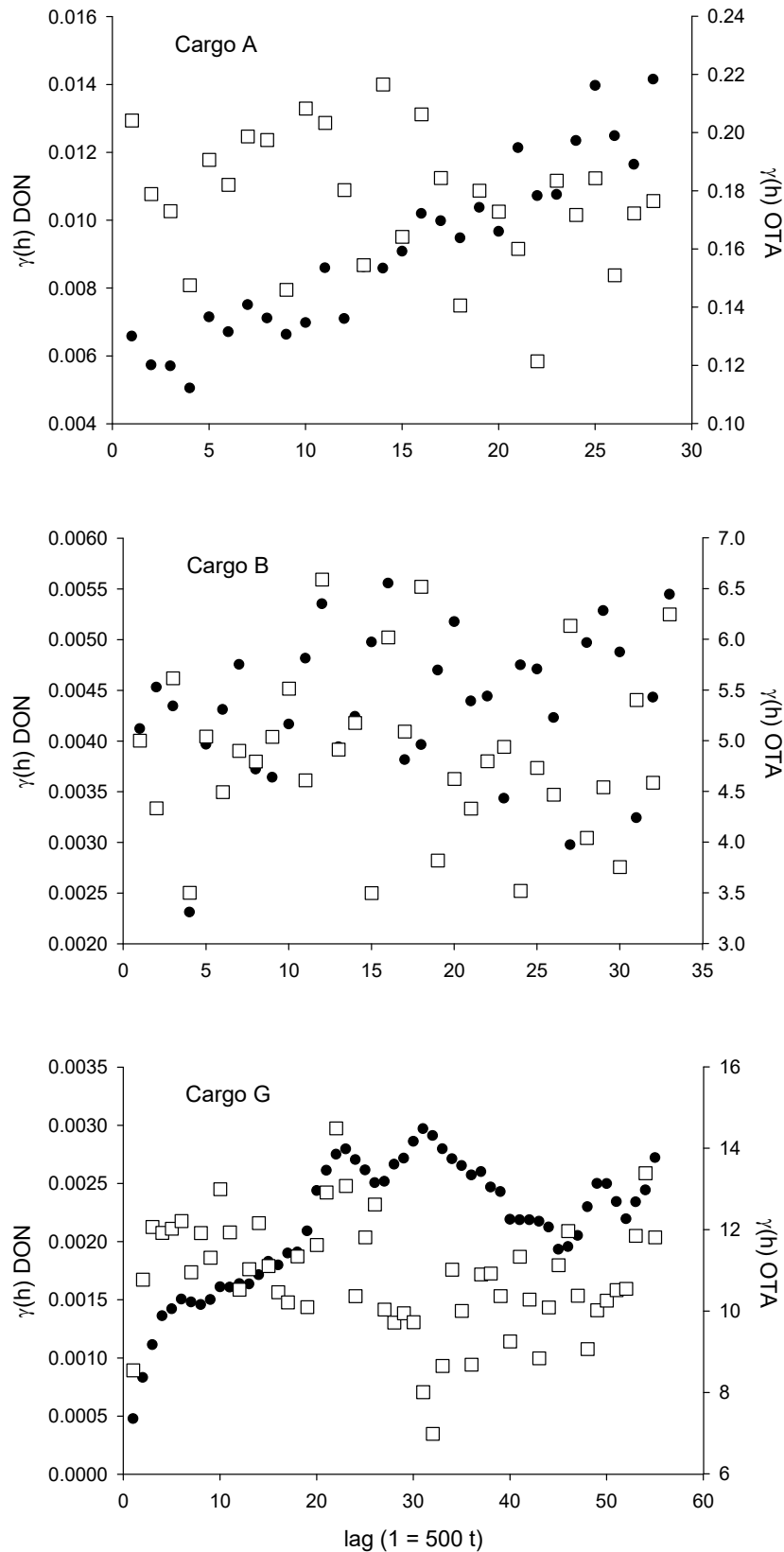

**Figure 5. Variograms of OTA (white squares) and DON (black circles) in 500 t sub-lot composites of three bulk wheat lots. Results below the limits of quantitation were set equal to the limits (OTA 0.5  $\mu\text{g}/\text{kg}$ ; DON 0.05  $\text{mg}/\text{kg}$ ).**

## Conclusions

The wide concentration ranges observed for both DON and OTA in individual wheat kernels indicate that there is a well-grounded risk for substantial compositional heterogeneity of mycotoxins within wheat in bulk lots. The wider range of OTA concentrations observed in single kernels as compared to DON, also suggested that there is a propensity for greater heterogeneity for OTA in wheat. However, other processes occurring along the grain handling chain were also noted to exert effects upon the heterogeneity of wheat.



As grain moves along the handling chain, it is combined with grain from various sources, which can alter its heterogeneity with respect to the presence of mycotoxins. The processes used in handling will also influence on heterogeneity. For example, the movement of grain in railcars could lead to a stratification of lighter *Fusarium* damaged wheat kernels, and therefore a stratification of DON within the bulk volume of such lots as the damaged kernels were shown to contain higher concentrations of DON.

Aspects of grain handling at terminal elevators will also influence the changing manifestations of wheat heterogeneity. During loading, grain with various quality aspects is often combined to meet customer specifications. Variograms helped visualizing the spatio-temporal variability of DON and OTA in wheat during loading of bulk volumes for shipment and highlighted both trends and cyclic variation of DON concentrations. These aspects of the DON variograms emphasize the need to take numerous increments during the entire loading process in order to obtain a composite that is representative of the entire bulk wheat volume.

The variability of DON and OTA concentrations in wheat observed at various steps and levels along the grain handling chain, from variation between kernels to variation during loading of tens of thousands of tonnes of wheat, to vessel loading, all contribute to the challenges encountered in sampling bulk grain for the mycotoxin analysis. These challenges are significant, but nothing that cannot be managed and resolved by diligent application of the stipulations in the framework of the Theory of Sampling (TOS)<sup>17-19</sup>.

## Acknowledgment

J. Arsuita, J. Bamforth, R. Blagden, J. Chan, D. Drul, T. Gräfenhan, W. Harnden, S.K. Patrick, M. Roscoe, M. Shahin, E. Thomas, and M. Tran (Canadian Grain Commission) all contributed to the preparation of test materials or analytical testing described in this paper.

## ORCID iDs

S.A. Tittlemier: <https://orcid.org/0000-0002-0426-5909>

## References

1. T.J. Ward, R.M. Clear, A.P. Rooney, K. O'Donnell, D. Gaba, S. Patrick, D.E. Starkey, J. Gilbert, D.M. Geiser, T. W. Nowicki, "An adaptive evolutionary shift in *Fusarium* head blight pathogen populations is driving the rapid spread of more toxigenic *Fusarium graminearum* in North America", *Fungal Genetics Biol.* **45**, 473-484 (2008).
1. J.L. Richard, "Some major mycotoxins and their mycotoxicoses--An overview", *Int J Food Microbiol.* **119**, 3-10 (2007).
2. Codex Alimentarius Commission, "Codex general standard for contaminants and toxins in food and feed. CODEX STAN 193-1995." (2016). Available from: [https://www.fao.org/input/download/standards/17/CXS\\_193e\\_2015.pdf](https://www.fao.org/input/download/standards/17/CXS_193e_2015.pdf).
3. World Trade Organization, Committee on Sanitary and Phytosanitary Measures, "Notification – Japan. G/SPS/N/JPN/567/Add.1", January 27, 2022.
4. European Union, "Commission regulation (EC) No 1881/2006 setting maximum levels for certain contaminants in food-stuffs" (2006).
5. S. Biselli, C. Persin, M. Syben, "Investigation of the distribution of deoxynivalenol and ochratoxin A contamination within a 26 t truckload of wheat kernels", *Mycotoxin Res.* **24**, 98-104 (2008).
6. L.P. Hart and O. Schabenberger, "Variability of vomitoxin in truckloads of wheat in a wheat scab epidemic year", *Plant Disease.* **82**, 625-630 (1998).
7. A.O. Mallmann, M.S. Oliveira, P. Dilkin, J.K. Vidal, G.R. Meinerz, C.A.A. Almeida, C.A. Mallmann, "Assessment of mycotoxin contamination in maize and wheat stored in silos using two sampling processes", *World Myco J.* **11**, 531-538 (2018).
8. S.A. Tittlemier, M. Roscoe, R. Blagden, C. Kobiak, "Occurrence of ochratoxin A in Canadian wheat shipments, 2010–12", *Food Add Contam: Part A.* **31**, 910-916 (2014).
9. Canadian Grain Commission, "Official Grain Grading Guide". (2021). Available from: <https://www.grainscanada.gc.ca/oggg-gocg/ggg-gcg-eng.htm>.
10. T. Gräfenhan, S.K. Patrick, M. Roscoe, R. Trelka, D. Gaba, J.M. Chan, T. McKendry, R.M. Clear, S.A. Tittlemier, "Fusarium damage in cereal grains from western Canada. 1. Phylogenetic analysis of moniliformin producing *Fusarium* species and their natural occurrence in mycotoxin contaminated wheat, oats, and rye", *J Agricult Food Chem.* **61**, 5425-5437 (2013).
11. Canadian Grain Commission, "Sampling systems handbook and approval guide", (2021). Available from: <https://www.grainscanada.gc.ca/guides-guides/ssh-mse/sshm-mmse-eng.htm>.
12. S. A. Tittlemier, M. Roscoe, C. Kobiak, R. Blagden, "Considerations in the preparation of laboratory samples for the analysis of ochratoxin A in wheat", *World Myco J.* **5**, 107-116 (2012).
13. L. Freese, R. Friedrich, D. Kendall, S. Tanner, "Variability of deoxynivalenol measurements in barley", *J AOAC Int.* **83**, 1259-1263 (2000).
14. M. Tomczak, H. Wiśniewska, Ł. Stępień, M. Kostecki, J. Chełkowski, P. Goliński, "Deoxynivalenol, nivalenol and moniliformin in wheat samples with heat blight (scab) symptoms in Poland (1998-2000)", *Eur J Plant Pathol.* **108**, 625-630 (2002).
15. J.C. Frisvad, U. Thrane, R.A. Samson, "Mycotoxin producers", in *Food Mycology: A Multifaceted Approach to Fungi and Food*. CRC Press Inc. pp. 135-159 (2007).
16. S.A. Tittlemier, R. Blagden, J. Chan, D. Gaba, T. McKendry, K. Pleskach, M. Roscoe, "Fusarium and Alternaria mycotoxins present in Canadian wheat and durum harvest samples", *Can J Plant Pathol.* **41**, 403-414 (2019).
17. K.H. Esbensen, *Introduction to the Theory and Practice of Sampling*. IMP Publications Open (2020).

18. F.F. Pitard, *Pierre Gy's Sampling Theory and Sampling Practice*. CRC Press (1993).

19. G.J. Lyman, *Theory and Practice of Particulate Sampling an Engineering Approach*. Materials Sampling & Consulting Pty Ltd (2019).



## Estimation of uncertainty for measuring metals content in waste printed circuit boards

A. Hubau<sup>a</sup>, S. Touzé<sup>b</sup>, S. Brochot<sup>c</sup> and P. Wavrer<sup>d</sup>

<sup>a</sup>BRGM – 3 avenue Claude Guillemin BP36009 – 45060 Orléans - France. E-mail: [a.hubau@brgm.fr](mailto:a.hubau@brgm.fr)

<sup>b</sup>BRGM – 3 avenue Claude Guillemin BP36009 – 45060 Orléans - France. E-mail: [s.touze@brgm.fr](mailto:s.touze@brgm.fr)

<sup>c</sup>CASPEO – 3 avenue Claude Guillemin BP36009 – 45060 Orléans - France. E-mail: [s.brochot@caspeo.net](mailto:s.brochot@caspeo.net)

<sup>d</sup>CASPEO – 3 avenue Claude Guillemin BP36009 – 45060 Orléans - France. E-mail: [p.wavrer@caspeo.net](mailto:p.wavrer@caspeo.net)

**The amount of waste printed circuit boards (WPCBs) currently represent a fast-growing issue that must be properly managed to limit their impact on the environment and human health. Due to their metal content, they can also be considered as a resource. Their characterization is a key point for evaluating different valorisation processes. The conventional methodologies to characterize wastes and/or metal resources are hardly applicable to such waste, as they are highly heterogeneous, difficult to micronize, and their individual components (plastics, glass, ceramics, and metals) are hard to liberate. Thus, in parallel to developing analytical tools that allow their accurate characterization, a sampling strategy suitable for WPCBs must also be established. In this study, an empirical approach was developed that aims at estimating the uncertainty arising from sampling WPCBs. To do so, the duplicate method of uncertainty estimation was followed, to compare the metal content in different sub-samples and to determine confidence intervals.**

### Introduction

Waste printed circuit boards (WPCBs) are gaining increasing importance due to their high metal content (around 30 to 40 wt%) and the increase of volumes that are produced. They are thus considered as a secondary resource, but also as potentially harmful wastes requiring to be handled with caution. While many studies deal with the development of new processes to valorise these wastes, there is very few studies dealing with the establishment of a sampling strategy enabling to obtain representative and reproducible samples. Three challenges are arising when developing a WPCBs sampling strategy. First, it is difficult to decrease the particle size of WPCBs. This issue is mainly linked to the presence of ductile metals, preventing the use of most of the conventional shredding and grinding equipment. The wet grinding processes produce wastewater that must be treated, while dry grinding processes produce dust, causing a potential loss of precious metals, as well as an increase of temperature that probably leads to the partial degradation of resins and plastics<sup>1</sup>. Secondly, these wastes are very heterogeneous, with a composition that changes over time. Some of the constituting materials (plastics, resins, glass, ceramics and metals) are embedded or diluted (as alloys) in other materials, preventing their complete liberation. There is also a large range of metal content, with metals that are highly concentrated (as Cu, with a content reaching up to 20 %w/w) or that are only present in PCBs as trace elements (as Pt, with less than 10 mg.kg<sup>-1</sup>). Finally, the last point concerns the lack of reference material, preventing to assess analytical uncertainty.

To the authors' knowledge, as of date, there is no adjustment of the Theory of Sampling (TOS) for WPCBs. The sampling strategies that are available in the literature on this material are mainly based on very small samples (around ten kilograms of WPCBs from a single batch at most) and are evaluating the quality of the last sampling step (production of the test portion used for the analysis). They are also based on pyrometallurgical approaches to reduce grinding issues and sample mass. However, this last strategy is not applicable when aiming at obtaining representative samples of WPCBs containing intact non-metal fractions (plastics and resins). Moreover, the quality of sampling is not evaluated in most of these studies. Due to the high heterogeneity of this material and the difficulty to obtain a complete liberation of constituting elements, the modelling approach to quantify the uncertainty, such as the one developed by Pierre Gy, is not applicable to the best of current knowledge, as there are no data available in the literature on the liberation factor, shape factor or constitution factor.

In this study, an empirical approach was chosen to estimate the uncertainty arising from sampling WPCBs. To do so, the duplicate method was applied to a unique batch of around 500 kg of WPCBs. As recommended in the Eurachem guide on measurement uncertainty<sup>2</sup>, the measurements of metal contents in WPCBs samples were replicated after successive shredding and subsampling steps (see Figure 1) and uncertainties were estimated at different levels of the sampling plan. To do so, the content of six metals (Cu, Fe, Ni, Zn, Pb and Co) was determined for two laboratory samples (LS) of 4 kg of -10 mm WPCBs. These two laboratory samples were ground to minus 750 µm and two 40 g test samples (TS) were taken for each. Each duplicate test sample was divided into 8 test portions (TP) which were analysed (Figure 1).

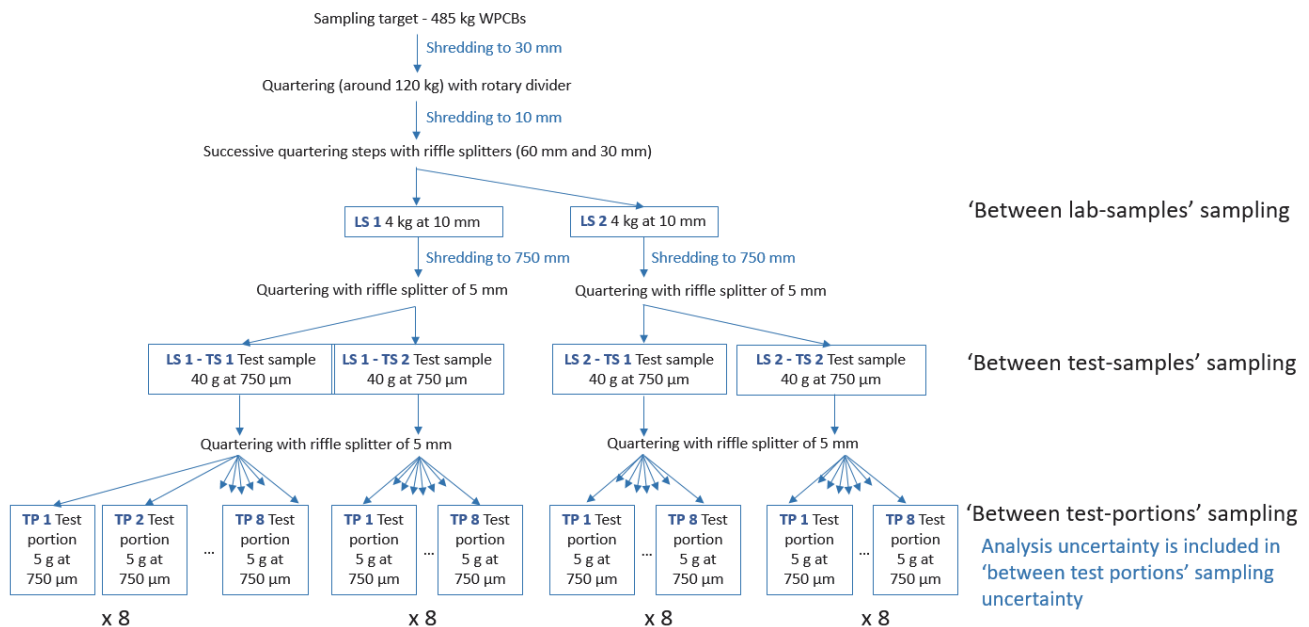

**Figure 1. Sampling plan used in this study.**

The sampling quality of “between laboratory samples (LS)”, “between test samples (TS)” and “between test portions (TP)” was evaluated. Some statistical tools were used to determine if the mean values of the test samples were significantly different. Variances and standard deviations were calculated and the contributions of “between test portions” sampling, “between test samples” sampling and “between laboratory samples” sampling to the total uncertainty were determined for each metal. Finally, intervals for the metal content values at 95 % confidence level were determined. The goal was to provide insights in the quality of sampling and to assess the reproducibility of the composition of sub-samples for further work on the development of WPCBs recycling technologies. From this study, a new sampling plan for extra batches of WPCBs could be designed.

## Materials and methods

### WPCBs sample, sampling and characterization

WPCBs used in this study were provided by a French recycling company, from the small waste electrical and electronic equipment category (mix of appliances such as computer, audio and video equipment, toys, personal care products, small kitchen appliances, etc.). The whole methodology used for sampling the 526 kg batch of WPCBs was previously detailed in Hubau *et al.* (2019)<sup>3</sup> and is given in Figure 1. Photographs of samples are given in Figure 2.

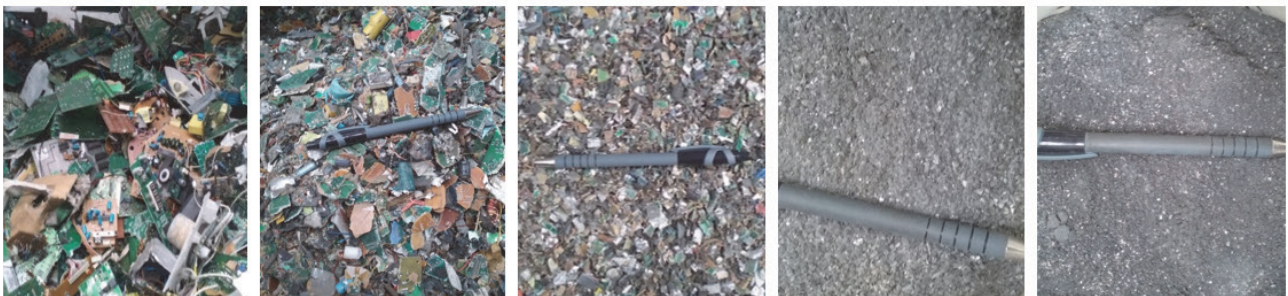

**Figure 2. WPCBs samples (raw material, -30 mm, -10 mm, -2 mm and -750 µm, from left to right).**

To determine metal contents, each test portion was digested with aqua regia (HNO<sub>3</sub>:HCl 1:3) with a solid to liquid ratio of 1:11 w/v. The digestions were performed using a Kjeldatherm-Gerhardt digestion system, maintaining the aqua regia at reflux for 2 hours. After solid-liquid separation, leachates were analysed by flame atomic absorption spectrometer (Varian SpectrAA-300). The efficiency of aqua regia digestion for such wastes has been previously demonstrated<sup>3,4</sup> (less than 2 wt.% of Cu, Zn, Sn, Pb, Co and Pd are undissolved, and less than 7 wt.% for other metals, except for Ta). The same operator performed all the grinding, quartering, digestion and analysis operations for all of the 32 test portions. In this study, the observed variability both includes the uncertainty arising from the sampling steps (TSE) as well as the total analytical error (TAE estimation is described elsewhere<sup>5</sup>).

### Statistical tools

After determining the standard deviation on the 32 measurements for each metal, it appears that the relative standard deviation is very large for Co (22.3 %) (Table 4). It is thus better to consider the natural logarithm of metal content values for the calculation of the uncertainty factors and for the application of statistic tests, as recommended by Eurachem guide<sup>2</sup>. Shapiro-Wilk tests were performed on these values to ensure that the hypothesis of log-normal distribution for metal contents cannot be rejected. For this study, the significance level for the p-value was fixed to 0.05. As demonstrated in Table 1,

hypothesis of log-normal distribution for metal contents in all the 32 test portions cannot be rejected. The hypothesis of normal distribution cannot be rejected too, while it is more difficult to conclude for Fe. These tests were also performed within each test sample ( $n = 8$ , data not shown) and similar results were obtained.

**Table 1. p-values obtained with normal and log-normal distributions of metal contents when considering the 32 test portions.**

Distribution	Cu	Fe	Zn	Pb	Ni	Co
Normal	0.657	0.067	0.884	0.200	0.489	0.204
Log-normal	0.662	0.172	0.802	0.614	0.210	0.766

Shapiro-Wilk tests were also performed on the residuals (difference between measured values and their estimates with the log-normal distribution), for which the hypothesis of normal distributions cannot be rejected, allowing to use ANOVA tool (Excel Stat 2019.3.2). Tukey tests of pairwise comparison were used to compare the mean values of each test sample. The significance level for Tukey test was fixed to 0.05.

#### Variance, standard deviation and uncertainty factor calculations

The calculation of variance was performed following the Eurachem guide methodology<sup>2</sup>. Variance can be calculated when a reasonable number of values are studied. However, as a misuse of language, Eurachem guide uses the term of variance for low number of samples (even 2) and this terminology was thus used in our study.

The formulas used to estimate the variance arising from “between test portions” sampling, from “between test samples” sampling and from “between laboratory samples” sampling are given in Table 2, with  $x_{i,j,k}$  referring to the natural logarithm of the metal content in the test portion  $k$ , from test sample  $j$ , from laboratory sample  $i$ .

**Table 2. Formula used to calculate the sum of squares, degree of freedom and variance for TP, TS and LS sampling stages.**

Formula	“Between test portions” sampling	“Between test samples” sampling	“Between laboratory samples” sampling
Mean value	$\bar{x}_{ij} = \frac{1}{N_{TP}} \sum_{k=1}^{N_{TP}} x_{ijk}$	$\bar{x}_i = \frac{1}{N_{TS}} \sum_{j=1}^{N_{TS}} \bar{x}_{ij}$	$\bar{x} = \frac{1}{N_{LS}} \sum_{i=1}^{N_{LS}} \bar{x}_i$
Sum of squares SS	$SS_{TP} = \sum_{i=1}^{N_{LS}} \sum_{j=1}^{N_{TS}} \sum_{k=1}^{N_{TP}} (x_{ijk} - \bar{x}_{ij})^2$	$SS_{TS} = \sum_{i=1}^{N_{LS}} \sum_{j=1}^{N_{TS}} \sum_{k=1}^{N_{TP}} (\bar{x}_{ij} - \bar{x}_i)^2$	$SS_{LS} = \sum_{i=1}^{N_{LS}} \sum_{j=1}^{N_{TS}} \sum_{k=1}^{N_{TP}} (\bar{x}_i - \bar{x})^2$
Degree of freedom df	$df_{TP} = N_{LS}N_{TS}(N_{TP} - 1)$	$df_{TS} = N_{LS}(N_{TS} - 1)$	$df_{LS} = N_{LS} - 1$
Variance Var	$Var_{TP} = \frac{SS_{TP}}{df_{TP}}$	$Var_{TS} = \frac{1}{N_{TP}} \left( \frac{SS_{TS}}{df_{TS}} - \frac{SS_{TP}}{df_{TP}} \right)$	$Var_{LS} = \frac{1}{N_{TP}N_{TS}} \left( \frac{SS_{LS}}{df_{LS}} - \frac{SS_{TS}}{df_{TS}} \right)$

For this study,  $N_{TP}$ ,  $N_{TS}$  and  $N_{LS}$  refers to the number of test portions (8), test samples (2) and laboratory samples (2) respectively, with the indices  $k$ ,  $j$  and  $i$  respectively,  $x_{ijk}$  being the logarithm of content in the TP  $k$  of TS  $j$  of LS  $i$ .

From this, the standard deviation (SD), the relative standard deviation (RSD), the expanded uncertainty factor ( $F_U$ ) and the limits for confidence interval for each contribution were calculated as follow (example given for TP sampling):

$$SD_{TP} = \sqrt{Var_{TP}}$$

$$RSD_{TP} = \frac{SD_{TP}}{\bar{x}}$$

$$F_{U_{TP}} = e^{2SD_{TP}}$$

$$\text{Lower confidence interval limit} = \frac{\bar{x}}{F_U} \text{ and Upper confidence interval limit} = F_U \cdot \bar{x}$$

For the expanded uncertainty factor, the coverage factor of 2 enables approximately a 95 % confidence on the calculated interval. When the calculated variance estimator is negative, it is supposed to be null.

## Results

### Pairwise comparison of mean values

The pairwise comparison of mean values was used to compare the metal contents of the test samples and determine if significant differences exist between mean values that could reveal a bias during the “between laboratory samples” sampling. To express the results of this Tukey test, mean values are associated to a group: two values are not in the same group if their mean values are significantly different (see Table 3). For example, Cu, Ni and Co mean values are all in the same group, meaning that there is no significant difference between mean values for the 4 test samples.

**Table 3. Mean value of metal content and results of the pairwise comparison of mean values from test portions with Tukey test.**

Metal	Cu	Fe	Zn	Pb	Ni	Co
Mean value (n=32)	15.4 %	12.5 %	1.68 %	1.23 %	3800 mg.kg <sup>-1</sup>	350 mg.kg <sup>-1</sup>
Test sample	Groups					
LS1-TS1 (n=8)	1	1-2	1	1	1	1
LS1-TS2(n=8)	1	1	1-2	2	1	1
LS2-TS1 (n=8)	1	1	2	2	1	1
LS2-TS2 (n=8)	1	2	1-2	3	1	1

For Fe and Zn, two different groups are observed, which means that there are some significant variations between mean values of some samples. However, the distribution between groups is not the same for both metals and some mean values are belonging to both groups. For Pb, there is a significant difference of mean values for all samples, except for LS1-TS2 and LS2-TS1 mean values. This distribution between groups is not linked to the laboratory sample from which they are originated, thus enabling to conclude that there is a sufficient degree of reproducibility between the laboratory samples (4 kg samples with particle size less than 10 mm). The variations observed between test samples are not caused by a bias during “between laboratory samples” sampling.

### Variance calculations

Following the duplicate methodology, it was possible to partition the total variance, to determine the contribution of all the studied sampling steps to the total variance. The total variance, given in Table 4, increases with decreasing metal content: Cu total variance is 0.00281 while its mean content is around 15.4 % (w/w), while it reaches 0.0485 for Co, which is much less concentrated in WPCBs (mean content around 350 mg.kg<sup>-1</sup>). The contribution of each sampling step variance to the total variance is given in Figure 3. Three classes of metals can be distinguished, correlated to their contents in WPCBs.

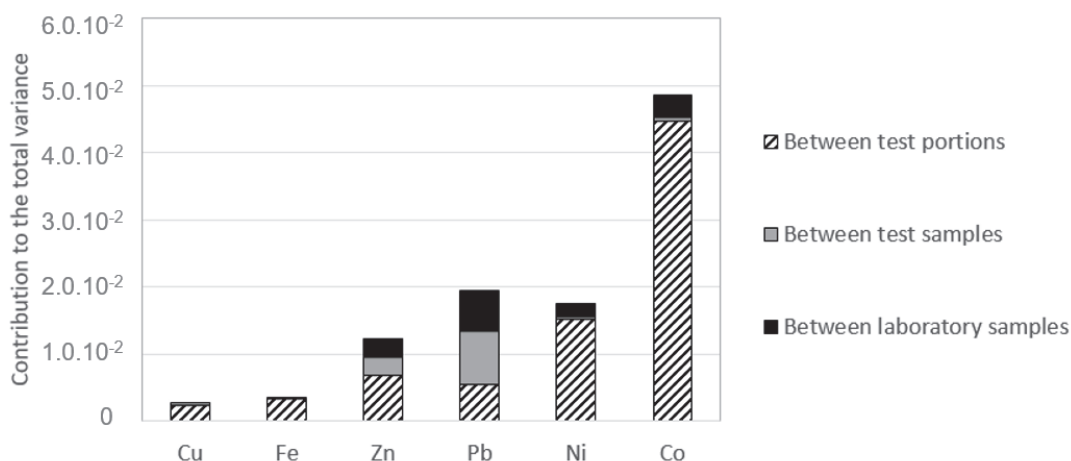
**Figure 3. Components of the variance of the logarithm of content for LS, TS and TP sampling stages contributions for the six metals.**

For Cu and Fe, the uncertainty arising from “between laboratory samples” sampling is calculated as zero, meaning that it is negligible compared to other contributions. This may be due to their high content in WPCBs and that for each piece of board, thus enabling a good distribution between the 4 kg samples at 10 mm. On the contrary, the “between test portions” sampling mainly contributes to the total variance. Two main hypotheses can explain this result: (i) first, this variance both includes the variance from analysis and from the “between test portions” sampling (this hypothesis is valid for all metals). This hypothesis and the corresponding uncertainty analysis is investigated and presented in another paper of WCSB10 proceeding<sup>5</sup>. (ii) Secondly, Fe and Cu are mainly present as coarse particles, with very high content, which are not easy to grind and are thus largely distributed in the -800 + 400 μm size fraction of the samples<sup>6</sup>. With these large particle sizes highly liberated, their distribution between the 5 g samples (test portions) may not be homogeneous, thus leading to the high contribution of the “between test portions” sampling step into the total variance.

For Zn and Pb, with mean contents reaching around 1.5 % (w/w), the contribution of the three sampling steps to the total variance are of the same magnitude. As previously observed with pairwise comparison of mean values, their distribution between the 4 kg sub-samples (laboratory samples) may already differ.

For Co and Ni, it appears that the “between test samples” sampling does not largely contribute to the total variance. The “between test portions” sampling is the main contributor of the variance, while there is also a contribution from the “between laboratory samples” sampling. Ni and Co are used as small batteries in WPCBs, which are supposed to be removed during the depollution of WPCBs (however not the case in this study). Ni may also be originated from stainless steel. In the -10 mm laboratory samples, there might be intact small batteries that are not equally distributed between samples, creating some variations due to nugget effect. That could cause the high values of “between laboratory samples” variances observed for Ni and Co compared to other metals. In the 5 g test portions, previous study<sup>4</sup> showed that erratic points might be observed for Ni and Co, maybe also due to the “nugget” effect, i.e., the occurrence of one or several tiny single flakes of concentrated metal in one test portion (however not observed at 750 μm in their study). These erratic points, which were not observed for Zn, Cu and Pb, might explain the large variance arising from “between test portions” sampling for Ni and Co.

These results show that the uncertainty is mainly due to the last sampling step (TP), except for Pb. It is therefore necessary to work on this step to reduce significantly the total uncertainty. Besides working on analysis uncertainties, it is possible to increase the mass of TP and/or decrease its particle size.

As observed by other authors<sup>7</sup>, the use of less than eight duplicates may increase the uncertainty on variance estimates. In this study, it could be very useful to supplement the data with other laboratory and test samples characterization. It is nevertheless interesting to see that for most metals that are studied, the highest uncertainty contribution originates from the sampling step with the larger number of replicates.

#### Uncertainty factor and 95 % confidence interval limits

From the total variance, the expanded uncertainty factor was calculated, then enabling to calculate the limits of the interval in which 95 % of the values of metal contents should be comprised. Results are given in Table 4. These intervals are not centred on the mean value as a log-normal distribution was used. As the objective of this study is to characterize the reproducibility of samples to use them for further developments of metal recovery processes, the knowledge of metal contents intervals helps to better characterize the initial content and thus the efficiency of the processes that are developed.

**Table 4. Mean content, relative standard deviation (RSD), total variance, total uncertainty factor and 95 % confidence interval limits for the six metals.**

	Metal content in %(w/w)				Metal content in mg.kg <sup>-1</sup>	
	Cu	Fe	Zn	Pb	Ni	Co
Mean value of metal content	15.4	12.5	1.68	1.23	3752	350
RSD (%)	5.8	6.9	10.3	12.5	13.3	22.3
Total variance*	2.81.10 <sup>-3</sup>	3.55.10 <sup>-3</sup>	1.22.10 <sup>-2</sup>	1.94.10 <sup>-2</sup>	1.75.10 <sup>-2</sup>	4.85.10 <sup>-2</sup>
Total uncertainty factor	1.11	1.13	1.25	1.32	1.30	1.55
95 % confidence interval limits	13.8 - 17.1	11.1 - 14.1	1.34 - 2.08	0.93 - 1.62	2850 - 4850	220 - 530

\* The total variance is calculated with the natural logarithm of metal content values, as explained in the Material and Methods section.

The width of these intervals is limited for Cu, Fe and Zn. However, for Pb, Ni and Co, these intervals are quite large. Two options emerge. For valuable metals that are in the scope of the process development, mass balances based on fine characterization of the outputs of the developed process are required to obtain accurate efficiency yields of the process. For other elements that are not targeted in the process but that may affect its efficiency, the knowledge of these intervals may be sufficient.

## Conclusion

This study gives an overview of the application of variance analysis to the sampling of WPCBs which are highly heterogeneous materials. From the pairwise comparison of the mean values, the calculation of variances and the determination of 95% confidence interval limits, this study assessed the quality of the WPCBs sampling plan that was used.

It appears that the “between laboratory samples” sampling (4 kg with particle size lower than 10 mm) partially contributes to the uncertainty. However, the distribution of metals in the two different laboratory samples that are studied was not highly affected by this sampling step. It would be of interest to increase the number of replicates at this step to confirm this result.

For most metals, the sampling of the test samples (40 g with particle size lower than 750 µm) does not highly contribute to the uncertainty on the metal content compared to the sampling of the test portions (5 g with particle size lower than 750 µm) as expected. The uncertainty calculated both arose from sampling and analysis. Based on a bootstrap strategy, previous work based on this last step evaluated the interest of replicating the test portions to reduce the uncertainty on metal content determination<sup>4</sup>. To do so, three test portion masses were used (0.5 g, 2 g, and 5 g) as well as three top particle sizes (200 µm, 750 µm and 2 mm). It concluded that for 5 g test portions, a 200 µm fineness drastically reduces the width of intervals in which metal content values are comprised, while a 750 µm fineness is a good compromise (when considering the time and energy consumption of the pulverizing step from 750 to 200 µm). That is consistent with the fundamentals of TOS: particle size, or diameter of the largest particles, must be reduced before reducing the sample mass if one do not want to increase the Fundamental Sampling Error (FSE). Nevertheless, the observed differences in variability cannot be only explained with this FSE approach<sup>5</sup>.

To go further, it could be interesting to consider trace elements that are valuable in WPCBs (critical metals such as Ga, Ta, Nd, La, Au, Pt, Pd). This will be in the scope of the MetroCycleEU project<sup>8</sup> funded by EMPIR EURAMET initiative, in which a similar sampling strategy will be developed and evaluated.

## ORCID iDs

A. Hubau: <https://orcid.org/0000-0002-3896-7220>

S. Touzé: <https://orcid.org/0000-0002-0840-4494>

S. Brochet: <https://orcid.org/0000-0002-9015-9693>



## References

1. M. Kaya, "Electronic Waste and Printed Circuit Board Recycling Technologies" in *The Minerals, Metals & Materials Series*. Springer International Publishing (2019). <https://doi.org/10.1007/978-3-030-26593-9>
2. M.H. Ramsey, S.L.R. Ellison and P. Rostron (eds) "Eurachem/EUROLAB/CITAC / Nordtest / AMC Guide: Measurement uncertainty arising from sampling: a guide to methods and approaches". Second edition, Eurachem (2019).
3. A. Hubau, A. Chagnes, M. Minier, S. Touzé, S. Chapron and A.G. Guezennec, "Recycling oriented methodology to sample and characterize the metal composition of waste Printed Circuit Boards", *Waste Management*, **91**, 62–71 (2019). <https://doi.org/10.1016/j.wasman.2019.04.041>
4. S. Touzé, S. Guignot, A. Hubau, N. Devau and S. Chapron, "Sampling waste printed circuit boards: Achieving the right combination between particle size and sample mass to measure metal content", *Waste Management*, **118**, 380–390 (2020). <https://doi.org/10.1016/j.wasman.2020.08.054>
5. S. Brochot, Ph. Wavrer, A. Hubau and S. Touzé, "Experimental determination of the constitutional heterogeneity for sampling of Waste Printed Circuit Boards", in *Proceedings 10th World Conference on Sampling and Blending (WCSB10), TOS forum* (2022).
6. A. Hubau, "Conception d'un procédé de biolixiviation pour la valorisation des métaux contenus dans les déchets de cartes électroniques (Design of a bioleaching process for the recovery of metals contained in spent Printed Circuit Boards)". PhD Thesis, Université Paris Sciences et Lettres, (2019).
7. J.A. Lyn, H. Michael, D. Ramsey, S. Coad, A. P. Damant, R. Wood and K.A. Boon, "The duplicate method of uncertainty estimation: are eight targets enough?", *Analyst*, **132**, 1147–1152 (2007). <https://doi.org/10.1039/b702691a>
8. MetroCycleEU project, <https://www.metrocycle.eu>

## Sampling of high-nugget conglomerates from the Western Australian Pilbara: Bulk sampling at the Beatons Creek gold project, Nullagine

Simon C. Dominy<sup>a,b,c</sup>, Alwin van Roij<sup>d</sup> and Janice C. Graham<sup>e</sup>

<sup>a</sup> Novo Resources Corporation, West Perth, WA 6005, Australia. E-mail: [simon.dominy@novoresources.com](mailto:simon.dominy@novoresources.com)

<sup>b</sup> Camborne School of Mines, University of Exeter, Cornwall TR10 9FE, UK. E-mail: [s.dominy@e3geomet.com](mailto:s.dominy@e3geomet.com)

<sup>c</sup> Western Australian School of Mines, Curtin University, Perth, WA 6102, Australia.

<sup>d</sup> Novo Resources Corporation, West Perth, WA 6005, Australia. E-mail: [alwin@novoresources.com](mailto:alwin@novoresources.com)

<sup>e</sup> Snowden-Optiro, Perth, WA 6000, Australia. E-mail: [jan.graham@snowdenoptiro.com](mailto:jan.graham@snowdenoptiro.com)

Many styles of gold mineralisation pose challenges during sampling because of the presence of coarse gold and high natural heterogeneity (“nugget effect”). The gold-bearing conglomerates of the Western Australian Pilbara provide some challenges. Novo Resources Corporation has addressed many of these over the last five years. Its Beatons Creek open pit operation is the first Pilbara conglomerate to go into production (January 2021) based on a total oxide Mineral Resource of 316,000 oz Au (5.2 Mt at 1.9 g/t Au at a 0.5 g/t Au cut-off). Mineralisation occurs within the Beatons Creek conglomerate member of the Hardey Sandstone formation, which constitutes part of the Fortescue Group. Gold is present within the matrix of multiple, narrow stacked and un-classified ferruginous-conglomeritic reef horizons, which are interbedded with un-mineralised conglomerate, sandstones and grits with minor intercalations of shale, mudstone, siltstone and tuffs. The gold occurs as free particles up to 5 mm across within the ferruginous matrix of the conglomerates. It is closely associated with detrital pyrite and authigenic nodules. Previous owners and Novo have employed several sampling techniques across the project including diamond and RC drilling, trench channel sampling and bulk sampling. Assay methods included fire assay, LeachWELL and more recently PhotonAssay. As part of its 2018 evaluation programme, fifty-eight c. 1–4 t bulk samples were collected from accessible oxide mineralisation and processed via a pilot plant. This paper presents some of the issues and solutions applied by Novo, which have wider implications and impact on the sampling of other heterogeneous orebodies.

### Introduction

#### Background

Sampling is a critical component throughout the mine value chain, it includes the sampling of both in-situ and broken material. In all cases, the aim is to gain a representative sample to accurately describe the material in question. The data produced must be fit-for-purpose to contribute to a Mineral Resource (and/or Ore Reserve) reported in accordance with an accepted international reporting code (e.g. 2012 JORC Code, CIM Code 2004, etc).<sup>1,2</sup> Quality assurance/quality control (QAQC) is critical to maintain data integrity through documented procedures, sample security, and monitoring of precision, accuracy and contamination.

Coarse gold-bearing mineralisation is generally characterised by a high in-situ nugget effect and prone to high sampling nugget effect if sampling activities are not optimised.<sup>3–7</sup> Particles greater than 100 µm in size are generally considered to be coarse. The sampling nugget effect is directly related to the sampling process: that is, to the size of the field samples taken; the effectiveness of collection; sample preparation (crushing, pulverising and splitting); the size of sub-samples after splitting; and analysis. Many of these problems can be overcome using larger sample and assay charges, and procedures to minimize sampling errors. Bulk sampling is an accepted method to drive validation of grade and metallurgical parameters in high-nugget mineralisation.

#### Bulk sampling

The aim of a bulk sampling programme is to de-risk a project by corroborating local grade estimates and metallurgical testwork (including ore sorter testwork) from drill holes and investigating scale-up and metallurgical responses.<sup>3,8–16</sup> In addition, they provide geological and geotechnical information on the underground or open pit extraction area. They are also used as part of focussed characterisation studies to investigate gold particle sizing in the context of grade and metallurgical properties.<sup>7,10,14–16</sup>

It must be understood that any bulk sample, group of bulk samples or trial mine lot (100s to 1,000s t scale) are unlikely to represent the entire resource.<sup>10,13</sup> It is likely that a local comparison can be made between the resource model and the bulk samples (or trial mine lot). If it can be demonstrated that the local area is a reasonable physical representation of the entire resource (or domain area), then the local validation (if proved) may be inferred globally. It is up to the qualified person (QP)/competent person (CP) undertaking the study to define what a reasonable comparison is, and to declare its basis in all public reporting.

Bulk sampling generally provides the most effective way to assess local grades in complex often coarse-gold high-nugget gold deposits, producing samples at the scale of tonnes. It is also used extensively in the evaluation of hard rock diamond deposits, which display extremely heterogeneous distributions.<sup>17,18</sup> A well-planned bulk sampling programme aims to evaluate mineralisation variability, the resolution of which may require multiple samples from several locations in specific domains. In addition, a programme needs to account for grade variability and not focus solely on high-grade or run-of-mine mineralisation. It should also evaluate difficult to process, as well as easy to process domains if required.

The term "bulk sample" is not rigorously defined and needs to be understood within the context of trial mining. The following definitions can be applied:<sup>10</sup>

- A bulk sample can be taken as the collection of a series of large, often >0.5 t to 100 t samples within a mineralised zone; and
- Trial mining may comprise the extraction of a series of contiguous bulk samples, or underground stopes or open pit bench comprising 100s t or more of rock.

The processing of bulk samples requires careful consideration, options include:

- 1) Whole lot or batch processing in a process plant;
- 2) Whole lot or sub-sample split through pilot plant; or
- 3) Lot splitting via a sampling tower for laboratory or pilot plant processing.

The first (1) option provides the most defensible results given that, assuming rigorous design and operation, all material is processed, and actual gold grade and recovery determined. With appropriate calibration, options (2) and (3) may lead to option (1), but only provide an estimate of gold grade and recovery. Further, option (3) may be problematic on a round-by-round basis unless the sampling protocol is rigorously defined. The decision of whether to use a mill or sampling tower is related to several issues which includes programme aims, mill or tower availability, cost, minimisation of sampling errors, and nature of the mineralisation.

Bulk sampling programmes are typically undertaken during pre-feasibility or feasibility studies. Critical aspects for consideration include sample representativity (sample mass); number of samples; spatial distribution through a domain(s); representation of the grade distribution; and sample processing. These aspects are frequently forgotten or ill-considered during the planning process. During programme planning, the QP/CP must consider the nature of the test area(s) and what the results are likely to mean.<sup>10</sup>

The location and number of bulk samples applied should reflect the grade distribution of selective mining units (SMU). This may not be possible depending on the stage of the project. Geostatistical simulation may be required to simulate SMU blocks.

## Theory of Sampling

Sampling remains a critical component throughout the mine value chain.<sup>6,19,20</sup> Without being able to analyse all material in advance, sampling of both in-situ and broken material serves to inform geological (resource and grade control), geoenvironmental and geometallurgical based mine planning and decision-making.<sup>6,15,16,20</sup> Sampling errors can generate both monetary and intangible losses.<sup>6,19-22</sup>

Representative samples are required to effectively evaluate the style of mineralisation in question.<sup>5,6,16</sup> This can be particularly challenging in deposits with coarse gold (>100 µm particles dominate), where large field samples and special preparation-assay protocols may be required.<sup>3,4,7-14,16,23</sup> Unrepresentative samples will not describe the true in-situ gold grade distribution and the overall result generally leads to a lower (undervalued) deposit mean grade.

The Theory of Sampling (TOS) aims to provide answers to two questions: how should a sample be selected and how much material should be taken? It defines a series of sampling errors which, if not minimised, lead to error and uncertainty in the final assay value.<sup>6,21,24</sup> TOS attempts to break down this error into a series of contributions from sample collection through to assaying. The sampling errors are defined in the TOS as promulgated by the works of Gy.<sup>6,21,24</sup>

Table 1 sets out the definitions of the various TOS sampling errors. The Fundamental Sampling (FSE) and Grouping and Segregation (GSE) Errors are irreducible random errors related to the inherent heterogeneity and characteristics of the material being sampled. They lead to poor precision and can only be minimised through good sampling protocols. The other errors arise because of the physical interaction between the material being sampled and the technology employed to extract the sample. They result in bias, which can be reduced by the correct application of sampling methods and procedures. A sample can be described as representative when it results in acceptable levels of bias and precision.<sup>6,21</sup>

**Table 1. Definition of TOS sampling errors.**<sup>6,21</sup>

Sampling error	Acronym	Error type	Effect on sampling	Source of error	Error definition
Fundamental	FSE	Correct Sampling Error (CSE)	Precision Generator Random Errors -	Characteristics of the mineralisation. Relates to Constitution and Distribution Heterogeneity	Results from grade heterogeneity of the broken lot. FSE does not cancel out and remains even after a sampling operation is perfect. Experience shows that the total nugget effect can be artificially high because sample weights are not optimal.
Grouping and Segregation	GSE				Relates to the error due to the combination of grouping and segregation of rock fragments in the lot. Once rock is broken, there will be segregation of particles at any scale.
Delimitation	DE	Incorrect Sampling Error (ISE)	Systematic Errors - Bias Generator	Sampling equipment and materials handling	Results from an incorrect shape of the volume delimiting a sample.
Extraction	EE				Results from the incorrect extraction of a sample. Extraction is only correct when all fragments within the delimited volume are taken into the sample.
Weighting	WE				Relates to collecting samples that are of a comparable support. Samples should represent a consistent mass per unit.
Preparation	PE				Refers to issues during sample transport and storage (e.g., mix-up, damage), preparation (contamination and/or losses), and intentional (sabotage) and unintentional (careless actions and non-adherence of protocols) human error.
Analytical	AE	Analytical		Analytical process	Relates to all errors during the assay and analytical process, including issues related to rock matrix effects, human error, and analytical machine maintenance and calibration.

The heterogeneity of a given variable (e.g., grade) can be quantified through the nugget effect and has a direct link to TOS.<sup>5–7,25</sup> The nugget effect is a quantitative geostatistical term describing the inherent variability between

samples at very small separation distances. The nugget effect has a wider remit than just differences between contiguous samples and its magnitude relates to the small-scale geological variation and sample measurement error.<sup>5-7,25</sup>

The geological component of the nugget effect expresses short-range data variability, which is particularly significant when samples are small, and protocols not optimised. The sampling component of the nugget effect expresses errors induced by inadequate sample mass, poor sample collection and preparation methods and poor analytical procedures. Throughout the mine value chain, sampling protocols should be optimised to reduce the sampling nugget effect which, in turn, reduces the total nugget effect, data skewness and the number of extreme data values.<sup>3,4,6,7,25</sup>

QAQC is critical to maintain data integrity through documented procedures, sample security and monitoring of precision, accuracy and contamination.<sup>26-28</sup> The ultimate test of any grade control programme comes through reconciliation of actual mine performance versus that predicted by grade control samples.

## The Beatons Creek Gold Project

### Introduction

The Beatons Creek gold project is in the East Pilbara Shire, between the major regional centres of Newman and Port Hedland, Western Australia. The project area is situated west of the town of Nullagine, which is 296 km southeast of Port Hedland and 170 km north of Newman.

Mineralisation consists of up to 2 m thick auriferous conglomerate reefs hosted by the Hamersley Basin of late Archaean-Paleoproterozoic age within the East Pilbara granite-greenstone terrain of the Early to Late Archaean Pilbara Craton on the north-western part of Western Australia.

There are no official records of gold production at Beatons Creek prior to 1897 and individual accounts of production post-1897 also vary. Most estimates suggest total production was <10,000 t for <4,000 oz Au at grades of between 15 g/t Au to 20 g/t Au. Localised high-grade pockets of mineralisation were mined underground in 1907-1912.

Modern evaluation did not commence until c. 1983, with various companies drilling up to 2007. Novo Resources Corporation (Novo: TSX.NVO) gained 100% control of the project in 2015 and continued drilling through to 2019, including a bulk sampling programme in 2018. The open pit mine went into production in January 2021.

### Geology of Beatons Creek

Mapping and drilling have confirmed the Nullagine sub-basin subdivision of the Hardey Formation at Beatons Creek. Mineralisation is restricted to a c. 200 m sequence of poorly-stratified, poorly-sorted, polymictic, pebble-to-boulder ferruginous conglomerate sequence. The underlying sequence is of similar composition, but finer and including sandstone beds and minor tuffs. These beds are characterised by a more regular sediment input and range between sandstone to pebble-conglomerates with several extensive tuff horizons.

The Beatons Mineralised unit and Beatons Middle unit form the c. 200 m thick package comprised of a monotonous sequence of pebble-to-boulder conglomerate with occasional thin interbeds of sandstone. Conglomerate clasts comprise sandstone, siltstone, quartz and dromedary boulders-conglomerates and resembling the Dromedary Hills Mosquito Creek conglomerate unit towards the east.

Regular 0.5 m to 2 m thick horizons show cobble to boulder conglomerates with increased resistive clasts and increased pyrite and represent fluvial channels (proximal to the depositional fan) or zones of marine reworking.

Gold-bearing ferruginous conglomerates are restricted to these channels or marine lags and constrained to the 40 m thick Mineralised Unit at the top of the sequence. Fluvial type conglomerates and marine lags have a clearly defined top and base and represent a higher energy environment conducive to concentrating gold, as well as detrital pyrite and resistive clasts. Gold mineralisation within the Beatons Creek conglomerates occurs as fine grains, larger flakes, and rounded particles rarely exceeding 5 mm in size. Coarse and fine gold is spatially related to higher concentrations of pyrite, and there seems a broad correlation with gold and the 'buckshot pyrite' clast size.<sup>30</sup> Coarse gold particles are regularly visible (Figures 1 and 2).



**Figure 1. Gold particles shown within blue circles amongst buckshot pyrite (black dots) from oxide channel conglomerate at South Hill.**



**Figure 2. Gold in drill core from fresh conglomerate, Grants Hill. Left: BCDD18-002, 0.5 m at 7.3 g/t Au. Right, BCDD18-001, 0.48 m at 4.3 g/t Au.**

Mineralisation is restricted to fluvial type channel conglomerates or marine lag reworked conglomerates and readily recognizable from outcrop and drill core. The wider Beatons Mineralised unit and Beatons Middle unit contain minor disseminated pyrite, but the background mineralisation is no more than 0.1 g/t Au.

### Channel Conglomerates

Fluvial type channel conglomerates are typically clast-supported, heterolithic, pebble-to-cobble conglomerate with occasional boulders (Figure 3). Imbrication of clasts is commonly evident indicating a general north to northwest flow direction in the project area, and trough cross bedding and channels are commonly evident, suggesting a braided river environment (Figure 4).

Individual channels are often c. 50 m across and can be traced over hundreds of meters. Thickness varies between 0.5 m to several meters. Clasts are dominantly sandstone, conglomerate, siltstone and shale locally derived from the nearby Mosquito Creek formation (+70%), and clasts of several types of metamorphic rocks and granite derived from the basement are less common (<10%), but ubiquitous. White and grey vein clasts are also

ubiquitous making up around 10% to 20% of the clast population; sand and silt dominate the matrix and spotty clusters of detrital pyrite (up to 1 cm diameter); as well as fine (<1 mm) rounded and box-work pyrite are common in matrix material, up to 10% of the rock.

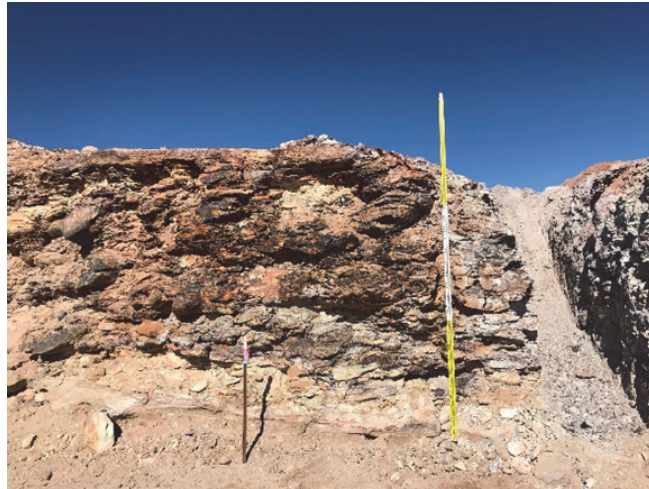

**Figure 3. Fluvial type oxide conglomerate exposed in 2018 bulk sampling program (thickness c. 1.8 m).**

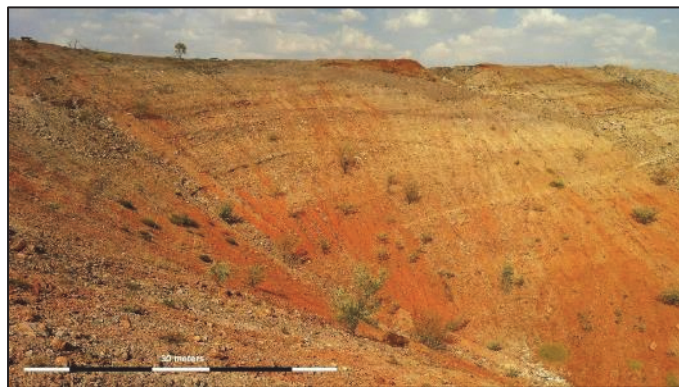

**Figure 4. Channel trough cross-bedding in a sequence of fluvial type conglomerates on the southern margin of Golden Crown.**

### Marine Lags

Marine Lags are typically tightly packed, clast supported cobble-to-boulder conglomerate (Figures 5 and 6). Individual boulders can exceed 1 m diameter and comprise a heterolytic composition, but are dominated by hard, resistant, siliceous dromedary boulders, vein quartz and chert. Sandstone and locally derived shale clasts are less common in marine lags and commonly tucked between or under larger siliceous boulders. Imbrication is rare and individual beds are 0.3 m to 1.5 m thick and sheet-like, being continuous over hundreds of meters with the main two marine lags continuous over 2.5 km. Sand and silt flakes of yellow shale comprise the matrix, with ubiquitous and abundant detrital pyrite (up to 3 cm diameter) is common in matrix material and can comprise up to 20% of the rock (Figure 7).



**Figure 5.** Tightly packed armored lag-type oxide conglomerate with quartz boulders from the M1 reef, Edwards area.



**Figure 6.** Armored lag-type oxide conglomerate comprising elongated quartz boulders in the M1 reef, Golden Crown area.

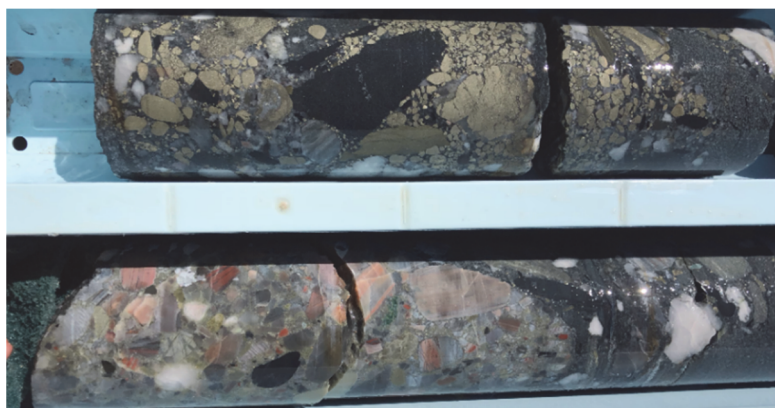

**Figure 7.** Detrital pyrite (upper) and dromedary boulder (bottom) in fresh mineralisation (PQ core) from Grants Hill.

All fault blocks apart from Golden Crown contain the M1 and M2 defined as the most dominant and consistent lodes. These represent the two most consistent marine lags and are always located in the same stratigraphic



sequence (noticeably the M1 approximately 12 m below the lowest marker Tuff, and the M2 approximately 10 m below the M1). This initial framework provides support to the geological continuity of the system. The M1 and M2 lodges are consistent over 2.5 km of strike (Figure 8).

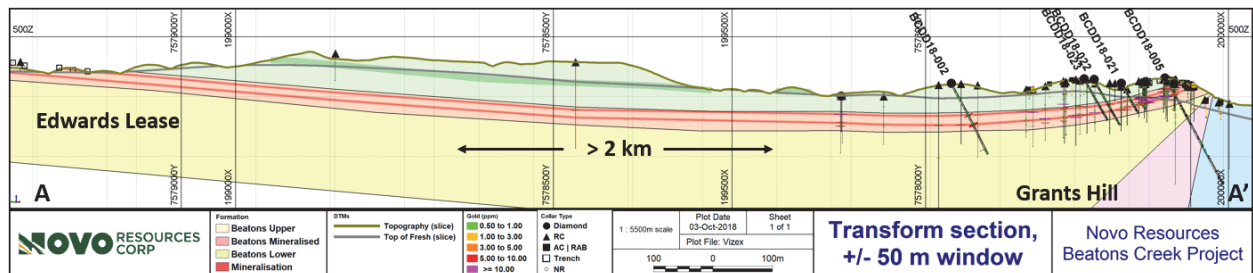

Figure 8. Cross section showing mine stratigraphy, marker tuff and M1 and M2 conglomerate reef continuity.

### Conglomerate Formation

Both fluvial and marine lag-type conglomerates are interstratified, indicating the depositional facies in which they formed were laterally proximal. The depositional environment for these conglomerates is interpreted to have been a river fan delta along a coastline as shown in Figure 9. During periods of low-stand, a braided river delta prograde seaward, depositing channelised fluvial type conglomerates. As sea levels rose, wave action winnowed out fine, light sediment leaving behind a transgressive armored lag deposit of large siliceous boulders and heavy minerals including gold. It is in this environment that the conglomerates at Beatons Creek formed. This process repeated several times to create the interbedded conglomerates exposed currently (Figure 9).

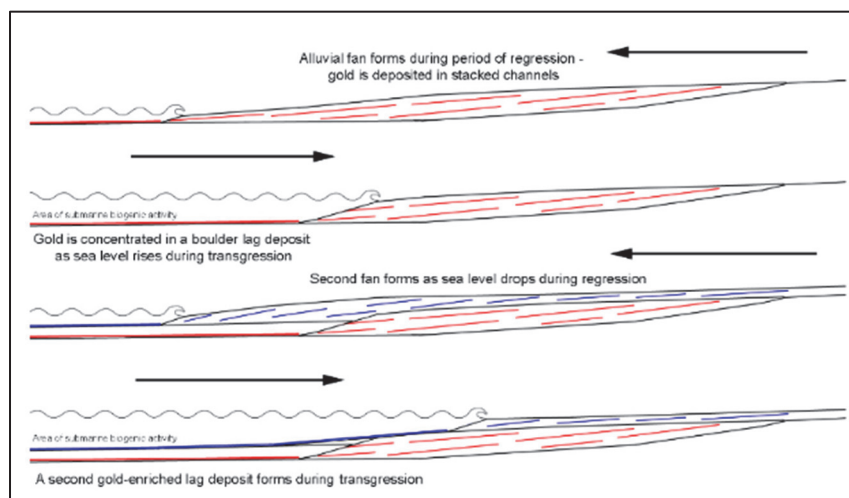

Figure 9. Sequence of two regressive and transgressive tracks from top to bottom.

The Palaeoplacer deposition model employed by Novo for the Beatons Creek project is based on detrital gold sourced from the nearby Mosquito Creek Formation and deposited locally. Mineralisation is further concentrated by reworking an already endowed sequence of conglomerates by marine processes as described above.

## Bulk Sampling Programme

### Introduction

Novo undertook a bulk sampling programme at Beatons Creek during 2018.<sup>29</sup> The samples were part of the evaluation programme attempting to quantify the magnitude and distribution of gold grades within marine and channel lag conglomerate reefs. Forty-five primary and 13 duplicate approx. 2 t bulk samples across 1 m (actual widths vary from 0.3 m to 1.7 m) increments of conglomerate were collected. The bulk samples were collected to investigate:

- (a) local grade at a large sample support;
- (b) comparison to the block model; and
- (c) metallurgical recovery.

The programme was key to support an updated Mineral Resource estimate that would be reported in accordance with Canadian National Instrument 43-101.<sup>29</sup> Samples were shipped to a commercial laboratory for pilot plant processing, and assaying of gravity concentrates, dust and tails samples.

### Sample Mass Optimisation

A review of historical metallurgical testwork and trial mining permitted a gold particle size-grade relationship to be inferred across the breakeven cut-off (BCOG: 0.5 g/t Au), run-of-mine (ROM: nominally 2 g/t Au) and high (5 g/t Au) grades.<sup>31,32</sup> The coarsest gold fraction indicates particles up to 5 mm (Figure 10).



**Figure 10. Very coarse gold fraction from a trial mining parcel collected/processed in 2017 yielding a head grade of 1.9 g/t Au.**

These were used to apply Poisson statistics to define an optimal field sample mass to achieve a precision of  $\pm 15\text{--}20\%$  at 90% reliability.<sup>10,31,32</sup> The masses indicated were based on interpretation of historical testwork results, which may or may not be representative of the oxide mineralisation. In addition, gold particle dimensions from testwork will always be less than the true in-situ particle size given comminution-liberation during testwork.

**Table 2. Grade-liberation diameter parameters, sampling constant and optimum sample mass values.**

Grade / parameter	0.5 g/t Au (BCOG)	2.0 g/t Au (ROM)	5 g/t Au (HG)
Liberation diameter [ $d_{Au95}$ ] ( $\mu\text{m}$ )	250-1,000	500-2,000	1,500-3,000
Sampling Constant (K) (>1,000 is High)	2,300 – 37,000	1,800 – 16,500	8,300 – 23,000
Optimum sample mass [ $\pm 15\text{--}20\%$ at 90% reliability]	0.1 – [2 t] – 3 t	0.1 – [1 t] – 2 t	1 – 8 t

Approx. 1-8 t samples were indicated to achieve  $\pm 15\text{--}20\%$  precision for high grade mineralisation (5 g/t Au), reducing to 1 t for ROM, and 2 t for BCOG mineralisation. Given a mean conglomerate thickness of 1 m, 2 t bulk sample were collected over 1 m of reef thickness. The sample area (2 m<sup>2</sup>) was kept constant, with reef thickness controlling the final sample mass.

Data Quality Objectives

Given the programme was to be used to support a Mineral Resource estimate, data quality objectives (DQO) were targetted during the design phase.<sup>31,32</sup> An existing block model (2018) was used to investigate the distribution of grades. Block grades between the 5<sup>th</sup> and 95<sup>th</sup> percentiles were targetted. The presence of surface channel samples were also used to assist with the placing of the samples. Bulk sample location was controlled by uneven topography and accessibility (Figures 11 and 12).

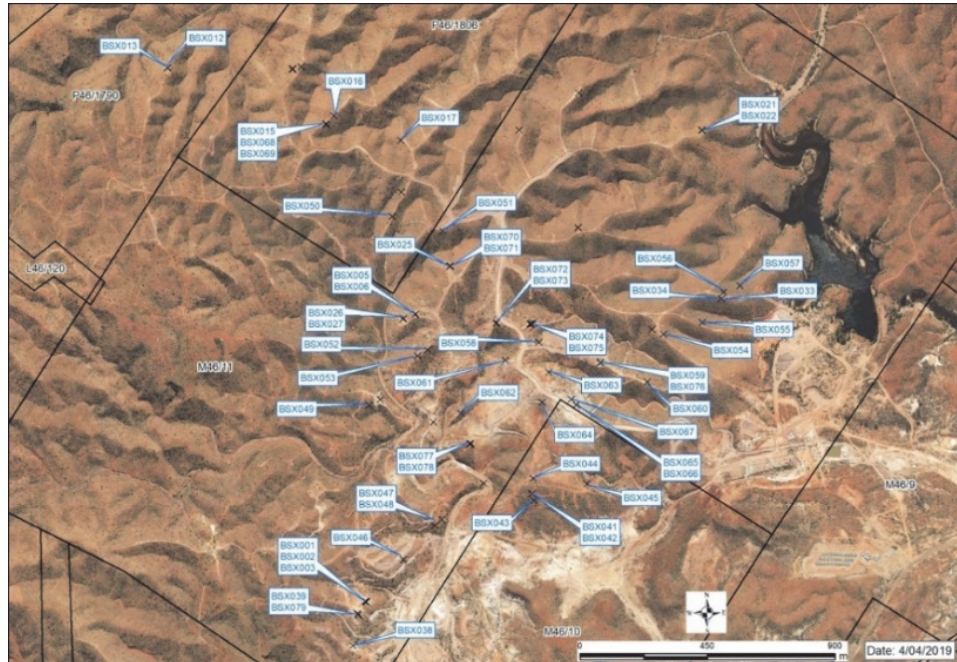

Figure 11. Bulk sample location map (refer to Figure 12).

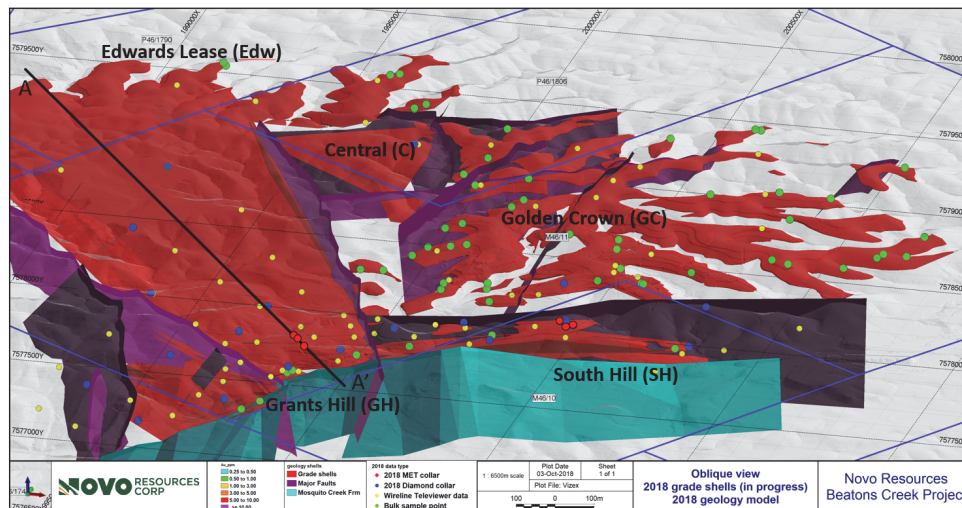
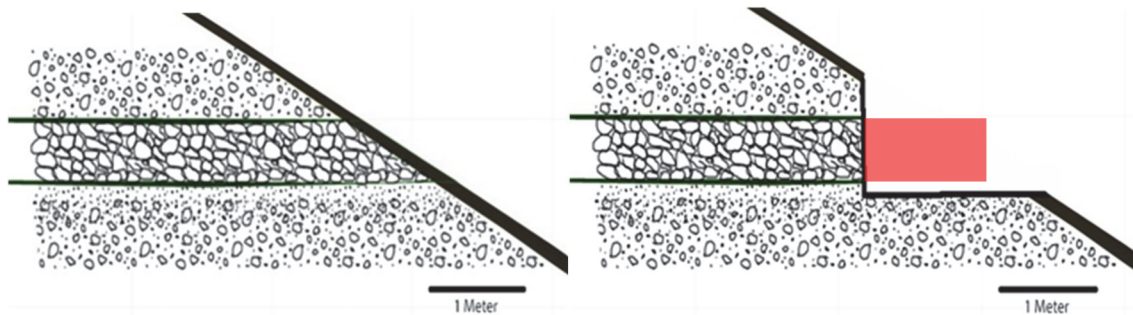

Figure 12. Bulk sample location (green dots) map in context of the resource wireframes.

Precision values (including the FSE) were optimised to be  $\pm 20\%$  or better.<sup>31,32</sup> Sample collection and splitting throughout the bulk sample process aimed to minimise all sampling errors (Table 1).

### Sample Collection

Sample collection was undertaken by Novo staff, comprising a geologist and field technicians. Once the surface had been cleared of vegetation, a trench was dug to expose a cross-section through the reef and ensure a sequence from the footwall through to the hangingwall was exposed (Figures 13 and 14).



**Figure 13.** After clearing of surface material, the bulk sample (red box) was cut from the ground to ensure effective extraction.

The geologist guided removal of overburden to expose a 2 m by 2 m area to allow the excavation of a 1 m by 1 m area sample to minimise hangingwall contamination. The sample outline was marked out using spray paint and the surface of the sample was surveyed using differential global positioning (DGPS) system (Figure 14).



**Figure 14.** Marked out sample ready for collection, through to removal and collected.

The top and bottom (hanging and footwall) contacts of the reef; top and bottom surface of the bulk sample and collar of the sample (centre of the bulk sample) were surveyed by DGPS. Wooden one-cubic metre sample crates were placed within the dump reach of an excavator (Figure 15). A poly-weave bulka bag was placed inside each crate. A metal hopper and grizzly were placed on top of the box and bag to protect the bag and act as a funnel for loading (Figure 15). Any oversize caught in the grizzly (>20 cm) was removed, broken up and returned to the box. On filling, the crate lids were screwed into position ready for road transport. Once the bulk sample interval had been excavated and cleaned, the sample floor was surveyed. After collection, no sample processing was undertaken on site prior to dispatch to the pilot plant Perth.



**Figure 15. Wooden shipping crates and metal hopper with grizzly.**

All aspects of the sample collection process aimed to minimise DE and EE. The delimited area was kept as tight as possible and all material in that area was collected. Sidewalls of the bulk sample cuts were generally stable. Inevitably there was some fines loss, though this was minimised by sweeping the cut floor.

### Bulk Sample Pilot Process

An analysis was undertaken as to the best way to process the bulk samples. Given the expected high level of coarse gold present, it was concluded that whole sample processing was the best option.<sup>31,32</sup> Any sample splitting prior to the extraction of coarse gold was likely to yield a high FSE, GSE, DE, EE and PE.

Fifty-eight samples were processed ranging in mass from 0.6 t to 4.9 t, with a mean of 2.3 t. At the pilot plant, samples passed through a staged crushing circuit that reduced the entire sample to P<sub>90</sub> -2.5 mm and then pulverised by hammer mill to a P<sub>90</sub> -0.75 mm (Figures 16 and 17C-D) and was fed to a gravity concentrator (Figures 16 and 17F). The key outputs were (1) gravity concentrate (generally 0.5-1 kg) and (2) 50 kg tails sample. The gravity concentrates were screen fire assayed to extinction. The gravity concentrate grade and tailings grades were combined to give the sample head grade. Key parts of the pilot plant process are shown in Figure 17.

The tails were passed through a slurry splitter to cut a 167 kg sub-sample for assay (Figure 17G), dried and then subsequently RSD split into a 50 kg sub-sample. This was pulverised to P<sub>80</sub> -200 µm and further split into a series of duplicate samples for assay via 2x 2.5 kg LeachWELL (with duplicate residue 30 g fire assay); 1x screen fire assay (1 kg); and 10x 0.5 kg PhotonAssay.<sup>33</sup> In all, 11 kg of the pulverised 50 kg tails split were assayed.

All sample splits were optimised to keep the FSE to less than ±15% at 90% reliability. All physical splitting activities were undertaken via a rotary sample/sectoral splitter (RSD) to minimise DE and EE (Figures 16 and 17G; slurry and RSD splitters).

Moisture and dust samples were collected as part of the process. Moisture samples (c. 5 kg of -2.5 mm material) were cut from the feed belt prior to the final hammer mill stage (Figure 16). Moisture content was <2%. Material

loss between the plant feed and prior to gravity concentration was between 1-4% by mass. This loss generally represented dust loss during the 5-stages of comminution. At selected times, vacuum units were used to collect dust for assay. These were assayed to extinction and contained <4% of the total sample gold.

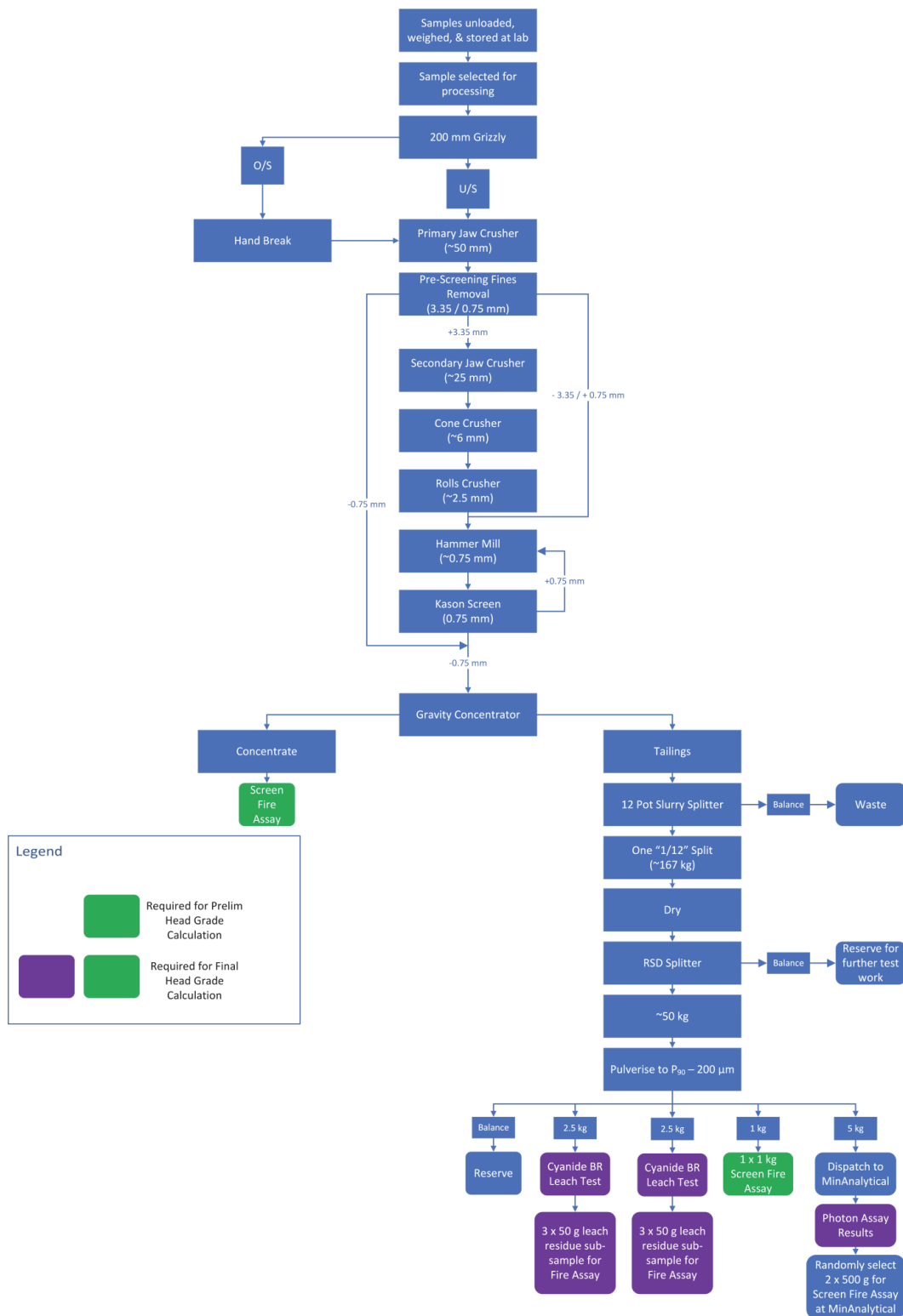

Figure 16. Beatons Creek bulk sample pilot plant process flow-sheet.



Figure 17. Bulk sample pilot plant: [A] Sealed samples boxes at the laboratory; [B] Tagged bulka bag within transport box; [C] Sample feed to primary crusher; [D] Rolls crusher; [E] Screen process; [F] Gravity concentrator; [G] Gravity tails splitter; [H] Tails samples ready for assay submission.

Pilot plant tails samples were assayed via the PhotonAssay method. Five kg of –200 µm material were split into 10x 0.5 kg charges for assay. The PhotonAssay method is a non-destructive and rapid gold assay technique capable of analysing coarse (crushed) 0.5 kg samples.<sup>33</sup> The PhotonAssay measurement precision varies from about 10% relative at a grade of 0.2 g/t Au to about 4% relative at a grade of 1 g/t Au. At grades of 10 g/t Au, the precision is 1.5% or better. The detection limit is approximately 0.03 g/t Au for typical samples.

### Quality Assurance / Quality Control

A QAQC programme was designed to support all aspects of the bulk sampling programme. Performance of the QC programme is summarised in Table 3. The relative sampling variability (RSV) is applied ( $RSV = [\text{standard deviation} / \text{mean}] \times 100$ ) as a precision metric.

**Table 3. Summary of bulk sampling programme QAQC outcomes.**

Action	Stage	Action	Rate	Actual KPI
Sample collection and integrity	Sample collection, weighing, containment, dispatch and receipt	Novo / Lab	All collection, transport and receiving supervised/inspected	In compliance
Field duplicates	Sample collection	Novo	Approx. 1 in 3	RSV ±22%
Blank	200–250 kg (1 drum) entire pilot process	Lab	Only 1 undertaken due to focus on processing actual samples	<0.1 g/t Au
Barren quartz flush	200–250 kg (1 drum) crush/grind circuit	Lab	1 in 1 flush Assay 1 in 2; split-off 5 kg and assay via 2x LW2500 + 2x SFA500 tails	0.02-0.25 g/t Au; mean 0.1 g/t Au
Pilot plant cleaning	Circuit cleaning between each sample	Lab	All	In compliance
Visual inspection	Crushers, hammer mill and RSD	Lab	All	In compliance
Tails duplicates	35 kg gravity tails second split	Lab	1 in 2	RSV ±15%
Pulp duplicates	Duplicate tails pulps 1 kg 5 kg	Lab	All SFA1000 PA5000	RSV ±30% RSV ±20%
Umpire	Tails 5 kg split	Lab	All (PA500 / 2x FA30)	RSV ±20%
CRM	Con. and tails assays	Lab	1 in 5	99% ±3σ Bias within ±5%
QAQC review	Throughout programme	Novo	Monthly	High compliance, minor issues only
Lab audit	Throughout programme	Novo	Monthly	All labs visited

RSV: Relative sampling variability; LW: LeachWELL; FA: fire assay; SFA: screen fire assay; PA: PhotonAssay.



## Programme Results

Bulk sampling programme global results are summarised in Dominy, Hennigh and Graham<sup>29</sup> and Table 4.

**Table 4. Global bulk sample results.**

Metric	<sup>1</sup> All	<sup>2</sup> BS+Dup_1	<sup>3</sup> BS+Dup_2
<b>Reported at 0 g/t Au cut-off</b>			
Number of bulk samples	58	45	45
Total mass (t)	136	104	104
Mass weighted grade (g/t Au)	2.16	2.23	2.17
Min. and max. grade (g/t Au)	0.20–6.16	0.20–6.16	0.20–6.16
Min. and max. true reef width [mean true width] (m)		0.30–2.52 [0.81]	
Grade RSV (%)	±66	±65	±68
<b>Reported above 0.5 g/t Au cut-off</b>			
No of bulk samples	52	43	43
Total Mass (t)	119	93	92
Mass weighted grade (g/t Au)	2.42	2.44	2.39
Grade RSV (%)	±57	±60	±61

<sup>1</sup> "All" refers to all bulk samples, including the field duplicates.

<sup>2</sup> "BS+Dup\_1" refers to the 45 primary bulk samples plus the primary samples of the field duplicates.

<sup>3</sup> "BS+Dup\_2" refers to the 45 primary bulk samples plus the field duplicates.

The global weighted grade above 0.5 g/t Au of the bulk samples (excluding the duplicate pairs) is 2.39 g/t Au and 2.44 g/t Au (Table 5; BS+Dup\_1 or Dup\_2), and including the duplicate pairs is 2.42 g/t Au. The bulk sample results by resource area are provided in Table 5.

**Table 5. Bulk sample results by resource area.**

Area	Reefs	<sup>1</sup> No. BS	Total tonnes (t)	Weighted grade (g/t Au)
Central	M1; M2	8	12.1	2.02
Golden Crown channels	930; 931; 934	3	7.2	2.21
Golden Crown marine	921; 922; 923	16	36.6	2.39
Grants Hill	M0; M1	9	23.6	2.58
North	M1	2	2.0	0.79
South Hill channels	341; 342; 343	7	21.9	1.84
Total		45	104	2.23

<sup>1</sup> Note Table uses the single non-duplicated values, refer Table 4 "BS+Dup\_1".

The bulk sample results by dominant reef are provided in Table 6.

**Table 6. Bulk sample results by dominant reef.**

Area	Reef	<sup>1</sup> No. BS	Total tonnes (t)	Weighted grade (g/t Au)
Central	M1	6	8.8	2.33
Grants Hill	M1	8	21.1	2.86
Golden Crown marine	922	10	25.6	2.65

<sup>1</sup> Note Table uses the single non-duplicated values, refer Table 4 "BS+Dup\_1".

## Bulk Sample Verification

On delivery to the pilot plant site in Perth, all sample boxes were checked for damage and to verify that the internal bulka bags and their seals were not broken. Novo staff visited the pilot plant on a weekly basis to inspect operations and sample progress. All assays (e.g. concentrates, and dust and tails samples) were provided as secured PDF certificates. The inputs to all bulk sample head grade calculations were checked by Novo against the original assay certificates.

Thirteen field duplicates were collected during the programme (Table 7). The duplicate sample was collected directly next to the original sample. The pairwise RSV value was 23%, which indicates that the bulk samples have

an acceptable level of precision. The field duplicate precision value includes all variability from in-situ nugget effect; to sample collection and preparation error and analytical error.

**Table 7. Beatons Creek duplicate bulk sample results.**

Original BS	Duplicate BS	Original grade (g/t Au)	Duplicate grade (g/t Au)	Absolute difference (g/t Au)
BSX05	BSX06	2.26	1.93	0.33
BSX12	BSX13	1.47	0.97	0.50
BSX15	BSX68	4.38	4.46	0.08
BSX21	BSX22	0.77	0.70	0.07
BSX25	BSX70	1.74	0.94	0.80
BSX26	BSX27	1.13	1.23	0.10
BSX33	BSX34	0.44	0.38	0.06
BSX39	BSX79	0.20	0.39	0.19
BSX68	BSX69	4.46	4.29	0.17
BSX70	BSX71	0.94	1.25	0.31
BSX72	BSX73	2.63	2.89	0.26
BSX74	BSX75	1.29	1.33	0.04
BSX77	BSX78	2.81	1.85	0.96
Mass weighted mean grade (g/t Au)		2.07	1.87	-
Pairwise RSV		±23%		

Twenty-five tails duplicates (e.g. 50 kg at –750 µm; Figure 13) were collected during the programme. The pairwise RSV value was 16%, which indicates that the sample tails split has an acceptable level of precision. The tails duplicate precision value includes all error from the RSD split through to the preparation and analytical error.

#### Bulk Sample Programme and Reconciliation with Estimate

The global weighted bulk sample grade is 2.16 g/t Au (for 136 t) and 2.42 g/t Au (for 119 t) if only samples above the resource cut-off grade of 0.5 g/t Au are considered. Table 8 shows a resource area reconciliation of samples with the 2018 trench channel samples (used in the resource estimate) and the local estimation block grade closest to each bulk sample. Figure 18 shows the distribution of bulk samples and block model (2019) grade within the Golden Crown marine lag (922 domain).

**Table 8. Bulk sample results by oxide resource area.**

Area	Reefs	No. BS <sup>1</sup>	Weighted BS grade (g/t Au)	2018 trench channel sample grade at BS sites (g/t Au)	Local block model grade at BS site (g/t Au)
Central	M1; M2	8	2.02	4.34	3.27
Golden Crown channels	930; 931; 934	3	2.21	1.21	2.93
Golden Crown marine	921; 922; 923	16	2.39	4.32	2.93
Grants Hill	M0; M1	9	2.58	4.99	2.90
North	M1	2	0.79	3.22	2.33
South Hill channels	341; 342; 343	7	1.84	3.94	2.23
Total		45	2.23	3.97	3.16

<sup>1</sup> Note Table uses the single non-duplicated values, refer Table 4 “BS+Dup\_1”.

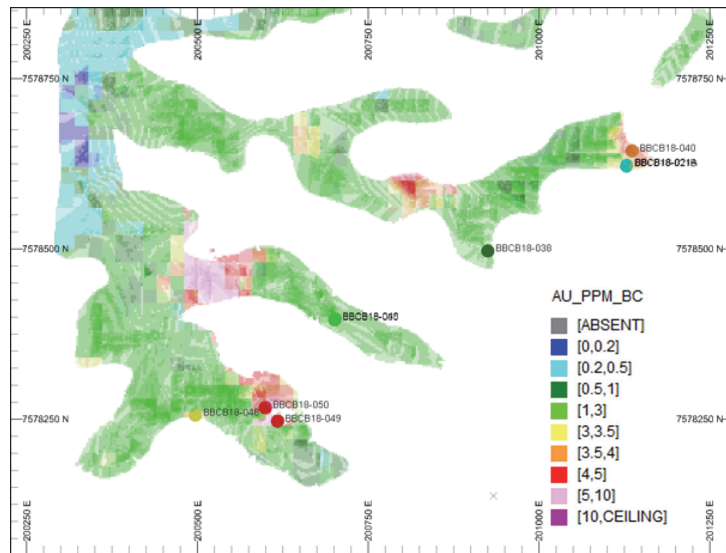

Figure 18. Golden Crown area reef domain 922 showing block model grades and bulk sample (N = 7) distribution and grade.

Figure 19 displays a log-probability plot comparing the bulk sample grades with the 2019 Indicated resource block model. The compared grade distribution is reasonable across the 5% to 95% probabilities.

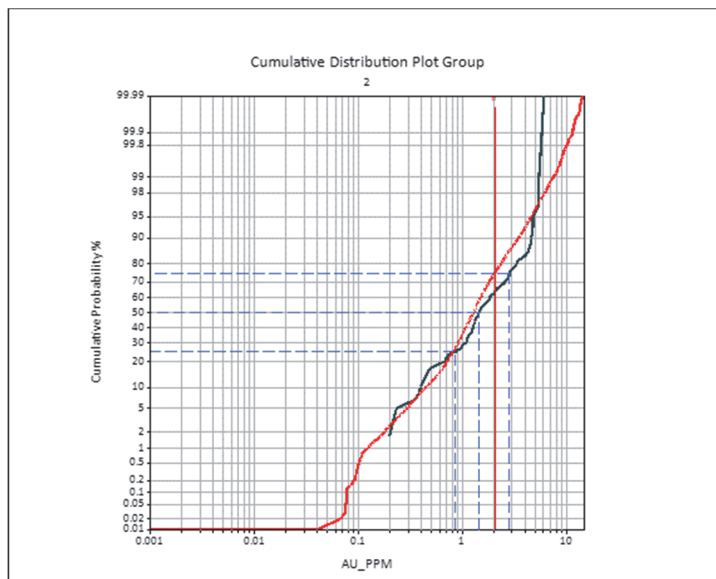

Figure 19. Log-probability plot of block model grade (red) versus bulk sample grade (black).

The local block model (i.e. the resource block that a bulk sample sits in) grades are generally higher than the bulk samples grades; globally 3.16 g/t Au versus 2.23 g/t Au. The trench channel grades are higher than the bulk sample grades; globally 3.97 g/t Au versus 2.23 g/t Au (Table 9).

Table 9. Comparison of mean grades across different sample supports in the oxide mineralisation Indicated Mineral Resource.

Support type	Trench channel sample mean grade at bulk sample sites (uncut grades)	Block model local (bulk sample sites) grades (cut grades in estimate)	Weighted bulk sample grades (uncut grades)	Block model global grade (cut grades in estimate)
Grade	3.97 g/t Au	3.16 g/t Au	2.23 g/t Au	1.88 g/t Au
Support mass	Multiple of c. 50 kg	960 t	2.3 t	960 t

Several issues are key:

- The comparison between a bulk sample (nominally 1 m by 1 m by 1 m; 2.3 t average mass) and an estimation block (nominally 20 m by 20 m by 1 m; 960 t) is not exact given the orders of magnitude difference in support.
- The trench channel samples were collected across the back of the extracted bulk sample void for comparison. It is known that the channel samples are biased high, due to the non-intentional selective sampling (e.g. EE) of the softer gold-bearing conglomerate matrix.
- In the block model-bulk sample comparison areas, trench channel samples dominate the input data and thus the block estimates are locally high.

The bulk sampling programme indicates that oxide mineralisation could locally yield grades of between 0.2 g/t Au and 6.2 g/t Au at a mean of around 2.23 g/t Au (undiluted). Individual or groups of bulk samples cannot be directly compared with resource blocks due to the two orders of magnitude difference in sample support, e.g. 2.3 t versus 960 t. A 960 t resource block could contain 417 bulk samples, which will show a range of grades, some of which will be below the cut-off grade.<sup>13</sup> The mining operation extracts on a selective mining unit (SMU) volume, which is less than the resource block and greater than the bulk sample volumes. At Beatons Creek the SMU block size is 5 m by 5 m by 0.5 m (c. 30 t of oxide mineralisation) based on 10 m by 10 m grade control drilling.<sup>34</sup>

The bulk sample results indicate that the resource grades are reasonable, given the high nugget nature of the mineralisation and sample support issues noted previously. The large estimation block size was applied to reduce conditional bias. There is no selectivity in the estimation blocks due to the smoothing nature of the high nugget effect.

### Production/Grade Control Sampling

Beatons Creek went into production in January 2021. For the year 2021, the operation produced 49,365 oz Au from 1.32 Mt at a head grade of 1.25 g/t Au.<sup>35</sup> Mining is guided by 10 m by 10 m spaced RC grade control drilling utilising 0.5 m composite lengths to produce a 5 m by 5 m SMU model (Figure 20).<sup>36</sup> Samples are 50/50 split at the rig (c. 7–9 kg) and submitted to an on-site laboratory where they are crushed to P80 –3 mm and 2–3 kg split off for total PhotonAssay.<sup>34,36</sup> The grade control programme is supported by a full QAQC system including field duplicates, lab duplicates, assay replicates, CRMs, umpire assays and blanks.<sup>37</sup>



**Figure 20. RC grade control drilling and sample bags awaiting laboratory submission (L) and grade control block model dig plan (R).**

Resource development RC drilling utilises a 20 m by 20 m spacing.<sup>34</sup> Samples are prepared and assayed in the same way as the grade control samples.<sup>36</sup>

### Conclusions

Bulk samples were collected following an initial review of historical metallurgical and mineralogical data to determine a grade-gold particle size relationship. The subsequent programme covered the broad grade distribution

spatially across several conglomerates and wholly within oxide mineralisation. The bulk samples were collected from what were classified as Indicated Mineral Resources. The programme was deemed to be fit for purpose based on an acceptable total sampling error component of  $\pm 23\%$ , and overall compliance with all QC requirements (Table 10).<sup>29</sup>

**Table 10. Risk review for the Beatons Creek bulk sampling programme.**

Key Parameter	Comment	<sup>1</sup> Component Error	TOS Error	<sup>2</sup> Error Rating
1	Spatial distribution and number of samples Samples collected across accessible surface areas of oxide conglomerate mineralisation 48 primary samples collected, with 10 field duplicate samples Reasonable representation of grade distribution (0.2 to 6.2 g/t Au)		ENE	Low
2	Sample mass (representativity) Indicated optimum mass approx. 1 t to achieve 68% $\pm 15\%$ 2 t samples collected across 1 m of conglomerate	20%		Low-mod.
3	Collection and handling Supervised collection of samples DGPS locations taken Samples placed into bulk bags		EE	Low
4	Transport and security All bulka bag samples secured into wooden containers Chain of custody recorded between mine and off-site laboratory Independent transportation of samples to SGS Perth		-	Low
5	Preparation Entire sample lot crushed and pulverised and passed through a gravity unit Tails sample split at -0.75 mm	16%	-	Low
6	Assay		-	Low
7	QAQC Full inspection and cleaning of pilot plant; barren flushes run between samples CRMs and blanks inserted at 1 to 25 rate in assay stream Full written protocols for the sampling-assaying process QC results within acceptable limits	-	-	Low
8	Validation/variability indicators Sample population RSV: 65%	Total 23%		Low-mod.
<b>Summary</b>				
Sample collection error rating (1)–(3)				Low
Preparation and assay error rating (4)–(7)				Low
Overall fit-for-purpose acceptance				Acceptable

<sup>1</sup> Component errors from limited duplicate pair analysis; <sup>2</sup> Indicative total error rating; red: high ( $> \pm 50\%$ ); orange: moderate ( $\pm 25\text{--}50\%$ ); low-moderate ( $\pm 20\text{--}35\%$ ); green: low ( $< \pm 25\%$ ). Percentages rounded to the nearest whole value.

From a grade perspective, the programme confirmed the tenor of the mineralisation, with the average grade across of the primary bulk samples (not duplicates) at 2.23 g/t Au (Table 9). It should be noted that the bulk samples were collected purposefully to minimise dilution, so that the grades achieved did not reflect those that may be achieved during mining. The global (Indicated) block model grade was 1.88 g/t Au compared to the bulk sample mean of 2.23 g/t Au. The local block model (immediately around the bulk samples) grade was higher at 3.16 g/t Au, reflecting the high-grade bias effect of the channel samples.

The programme indicated that even at a coarse grind size of 750  $\mu\text{m}$ , good recoveries were possible via gravity (average of 62% recovery).

## Recommendations

Bulk sampling programmes require effective planning based on ore characteristics, where protocols must fit the mineralisation type. Key areas for consideration include:

- Bulk sample site(s) requires representation of both grade spatial and population distribution within the ore zone.
- A programme requires definition of aims and DQOs, across grade and metallurgical parameters.
- Programme aims must consider the nature and quality of the estimate(s) being tested. Specific consideration is required of estimation block size and bulk sample size in context of data spacing.
- The application of a mill or sampling tower needs to carefully consider mill or tower availability, programme cost, DQOs (incl. achievable FSE) and sampling error minimisation, and nature of the mineralisation.

## Acknowledgments

Current and previous Novo staff are thanked for their contribution to the bulk sampling programme including Dr Quinton Hennigh, Kas De Luca, Don Frost and Pete Gough. The pilot plant was owned and operated by SGS Minerals Pty Ltd. Assay services were provided by MinAnalytical Pty Ltd and SGS Minerals Pty Ltd. The programme was led by Chris O'Brien with Victoria Arrowsmith managing the pilot process, supported by Brendan Parker (Chemtech Consulting Pty Ltd). At SGS, John Pizimolas, Matt Pupazzoni and Chris Casingena led the plant operations team. Grade and geological modelling were undertaken using Datamine RM software. Professor Kim Esbensen is thanked for comments on the manuscript, and Dr Anne Cole for assistance with formatting. Professor Hylke Glass and Saranchimeg Purevgerel are thanked for discussions on many sampling related topics.

## Abbreviations

The following abbreviations are used in this manuscript:

AE	Analytical error
BCOG	Breakeven cut-off grade
CP	Competent Person (JORC, 2012)
CRM	Certified reference material
DE	Delimitation error
DGPS	Differential global positioning system
$d_{95Au}$	Liberation diameter for sampling purposes
DQO	Data quality objectives
EE	Extraction error
FA	Fire assay (assay charge size 30 g; FA30)
FSE	Fundamental sampling error
GSE	Grouping and Segregation error
LW	LeachWELL assay (assay charge size 500 g; LW500)
$P_{80}$ or $P_{90}$	Percent passing (e.g., $P_{90}$ ; 90% passing a given screen size)
PA	PhotonAssay
PE	Preparation error
ROM	Run of mine grade
RSD	Rotary sample divider
RSV	Relative sampling variability
SFA	Screen fire assay (assay charge size 500 g; SFA500)
SMU	Selective mining unit
TOS	Theory of Sampling
QAQC	Quality assurance/quality control
QP	Qualified Person (National Instrument 43-101)

ORCID iDs

Simon C. Dominy: <https://orcid.org/0000-0002-0638-3693>

## References

1. JORC Code, "Joint Ore Reserves Committee (JORC), Australasian Code for Reporting of Exploration Results, Mineral Resources and Ore Reserves—The JORC Code", Joint Ore Reserves Committee of the Australasian Institute of Mining and Metallurgy, Australian Institute of Geoscientists and Minerals Council of Australia, p. 44 (2012).
2. CIM Code, "CIM Definition Standards for Mineral Resources and Mineral Reserves", CIM Standing Committee on Reserve Definitions, p. 10 (2014).
3. S.C. Dominy and J.S. Petersen, "Sampling coarse gold-bearing mineralisation - developing effective protocols and a case study from the Nalunaq mine, southern Greenland", in *Proceedings Second World Conference on Sampling and Blending*. AusIMM, pp. 151-165 (2005).
4. S.C. Dominy, "Sampling coarse gold-bearing mineralisation – developing effective protocols and a case study from Ballarat, Australia", in *Proceedings Proceedings Eighth World Conference on Sampling and Blending*. AusIMM, pp. 71-84 (2017).
5. F.F. Pitard, "The in-situ nugget effect: a major component of the random term of a variogram", in *Proceedings World Conference on Sampling and Blending*. Fundacao Luiz Englert, pp. 91-110 (2007).
6. F.F. Pitard, "Theory of Sampling and Sampling Practice", CRC Press, pp. 694 (2019).
7. S.C. Dominy, "Predicting the unpredictable – evaluating high-nugget effect gold deposits", in *Mineral Resource and Mineralisation Reserve Estimation – The AusIMM Guide to Good Practice, Monograph #23*. AusIMM, pp. 659-678 (2014).
8. E.C. Cintra, J.A. Scabora, E.P. Viegas, R. Barata and G.F. Maia, "Coarse gold sampling at Sao Francisco mine, Brazil", in *Proceedings World Conference on Sampling and Blending*. Fundacao Luiz Englert, pp. 187-197 (2007).
9. S.C. Dominy, A.E. Annels, G.F. Johansen and B.W. Cuffley, "General considerations of sampling and assaying in a coarse gold environment", *Applied Earth Sciences*. **109**, 145-167 (2000). doi.org/10.1179/aes.2000.109.3.145
10. S.C. Dominy, I.M. Platten and Y. Xie, "Bulk sampling of complex gold deposits: material characterisation and programme design and management", in *Proceedings Sampling Conference*. AusIMM, pp. 41-57 (2008).
11. G.F. Johansen and S.C. Dominy, "Development of sampling protocols at the New Bendigo gold project, Australia", in *Proceedings Second World Conference on Sampling and Blending*. AusIMM, pp. 175-183 (2005).
12. H. Thalenhorst and D. Dumka, "Bulk sampling of mineral projects using a sample tower: lessons from the field", *CIM Journal*. **1**, 44-54 (2010).
13. I. Clark and S.C. Dominy, "Underground bulk sampling, uniform conditioning and conditional simulation - unrealistic expectations", in *Proceedings of the Eighth World Conference on Sampling and Blending*. AusIMM, pp. 3-19 (2017).
14. S.C. Dominy, L. O'Connor, H.J. Glass and Y. Xie, "Geometallurgical study of a gravity recoverable gold orebody", *Minerals*. **8** (2018). doi.org/10.3390/min8050186
15. S.C. Dominy, L. O'Connor, H.J. Glass, S. Purevgerel and Y. Xie, "Towards representative metallurgical sampling and recovery testwork programmes", *Minerals*. **8** (2018). doi.org/10.3390/min8050193
16. S.C. Dominy, L. O'Connor and S. Purevgerel, "Importance of representative metallurgical sampling and testwork programmes to reduce project risk—a gold case study", *Mining Technol.* **128**, 230-245 (2019) doi.org/10.1080/25726668.2019.1628462
17. L. Rombouts, "Assessing the diamond potential of kimberlites from discovery to evaluation bulk sampling", *Mineralium Deposita*. **38**, 496-504 (2003). doi.org/10.1007/s00126-002-0313-4
18. J.J. Langenhoven, "The application of Gy's formula and sampling best practice at the Snap Lake (Canada) Phase I diamond bulk sampling plant", in *Proceedings Second World Conference on Sampling and Blending*. AusIMM, pp. 193-204 (2005).
19. P.C. Carrasco, P. Carrasco and E. Jara, "The economic impact of incorrect sampling and analysis practices in the copper mining industry", *Chemom. Intell. Lab. Sys.* **74**, 209–214 (2004). doi.org/10.1016/j.chemolab.2004.04.013
20. S.C. Dominy, "Importance of good sampling practice throughout the gold mine value chain", *Min. Technol.* **125**, 129–141 (2016). doi.org/10.1179/1743286315Y.0000000028
21. P.M. Gy, "Sampling of Particulate Materials: Theory and Practice", Elsevier, p. 431 (1982).
22. R.C.A. Minnitt, "Sampling: The impact on costs and decision making", *J. South. Afr. Inst. Min. Metall.* **107**, 451–462 (2007). doi.org/10.10520/AJA0038223X\_3284

23. S.C. Dominy and I.M. Platten, "Clustering of gold particles and implications for sampling", *Appl. Earth Sci.* **116**, 130–142 (2007). doi.org/10.1179/174327507X207474
24. D.M. François-Bongarçon and P.M. Gy, "The most common error in applying Gy's formula in the theory of mineral sampling and the history of the Liberation factor", *J. South. Afr. Inst. Min. Metall.* **102**, 475–479 (2002).
25. D.M. François-Bongarçon, "Theory of sampling and geostatistics: an intimate link", *Chemom. Intell. Lab. Syst.* **74**, 143–148 (2004). doi.org/10.1016/j.chemolab.2004.03.015
26. C.R. Stanley and D. Lawrie, "Average relative error in geochemical determinations: Clarification, calculation and a plea for consistency", *Explor. Min. Geol.* **3–4**, 267–275 (2007). doi.org/10.2113/gsemg.16.3-4.267
27. C.R. Stanley and B.W. Smee, "Strategies for reducing sampling errors in exploration and resource definition drilling programmes for gold deposits", *Geochem. Explor. Environ. Anal.* **7**, 329–340 (2007). doi.org/10.1144/1467-7873/07-128
28. S.C. Dominy, S. Purevergel and K.E. Esbensen, "Quality and sampling error quantification for gold mineral resource estimation", *Spec. Europe.* **32**, 21-27 (2020).
29. S.C. Dominy, Q.T. Hennigh and J.C. Graham, "Mineral Resource update, Beatons Creek conglomerate gold project, Pilbara Region, Western Australia", *NI 43-101 Technical Report by Novo Resources Corporation*, pp. 139 (2019).
30. P.C. Gough, "A petrographic study and genesis model of the auriferous conglomerates at Beatons Creek, Nullagine, WA", *Unpublished MSc Thesis, Camborne School of Mines*, pp 95 (2014).
31. S.C. Dominy, "Bulk sample representative mass study - Beatons Creek gold project, Nullagine, WA", *Unpublished report by Novo Resources Corporation*, pp. 31 (2018).
32. S.C. Dominy, "Resource development programme, including bulk sampling - Beatons Creek gold project, Nullagine, WA", *Unpublished report by Novo Resources Corporation*, pp. 95 (2018).
33. C.D. Tremblay, J. Tickner, D. Treasure, A. Oteri and G. Wheeler, "PhotonAssay - efficient and bulk gold analysis in the modern world", in *Proceedings of the International Mining Geology Conference*. AusIMM, pp. 88-98 (2019).
34. S.C. Dominy and J.C. Graham, "Grade control programme – Beatons Creek gold project, Nullagine, WA", *Unpublished report by Novo Resources Corporation*, pp. 183 (2020).
35. "Novo Reports 2021 Financial Results", News Release by Novo Resources Corporation dated 1<sup>st</sup> April 2022.
36. S.C. Dominy and J.C. Graham, "Beatons Creek gold project grade control programme – Stage 1: sensitivity and optimisation analysis and recommendations", *Unpublished report by Novo Resources Corporation*, pp. 120 (2021).
37. S.C. Dominy, "Beatons Creek gold project: Protocols and KPIs for resource development and grade control drilling, sampling and QC", *Unpublished report by Novo Resources Corporation (January 2022 revision)*, pp. 11. (2022).





## Mobile dust sampling device for dust filter generation at a Ni refinery

Oluf Bøckman<sup>a</sup> and Hege Indresand<sup>b</sup>

<sup>a</sup>Glencore Nikkelverk AS, Vesterveien 31, 4613 Kristiansand, Norway. E-mail: oluf.bockman@glencore.no

<sup>b</sup>NORCE Norwegian Research Centre AS, Postboks 22 Nygårdstangen, 5838 Bergen, Norway. E-mail: hein@norceresearch.no

To study the distribution of Ni emission to air from the myriad of point and diffuse sources within a plant site is a complex sampling and analysis problem. However, it provides important underlying information for source abatement. At a Ni refinery in Southern Norway such sampling of Ni in air in close proximity to sources with subsequent analysis of content or particle structures by various methods has always been a complicated endeavour with no or inconclusive results. The main difficulty lies in obtaining both a representative and a large enough sample size to achieve quality results within a reasonable cost budget.

Normally a filter sample of dust used for the chemical analysis of Ni in air is collected with fairly expensive reference instrumentation. If more than one filter sample is needed, e.g. several copies of a specific sampling period and location, several co-located instruments should be used, or one filter is cut into several pieces for post-analysis. Cutting a filter in pieces will compromise the sample and chemical analysis and most reference PM samplers are not easily or cheaply operated and transportable.

Thus, a novel in-house sampling device that delivers 3 independent and parallel filters simultaneously was constructed. The goal was to obtain triplet sample sets from many locations inside the plant area. The sample sets could be screened for Ni levels and provide filter copies for advanced chemical analysis when needed. Comparisons of individual samples in sets of varying Ni content showed satisfactory equivalence.

The sampling device is continuously used in a pilot Ni ambient distribution study within the plant site. The triplet sampler has been rotated at more than 10 sites since 2015. The sites varied between being on the ground and on roof tops of buildings. Some locations were near potential sources that give diffuse emissions of nickel dust. Results have been used to understand the Ni variation spatially and to identify important contributing sources to the total Ni emissions that potentially is emitted to the surrounding airshed. Parallel samples have been sent for more advanced post-analysis for periods with known elevated nickel concentration. The results have yielded more defensible abatement plans and more effective abatement measures.

### Introduction

Glencore Nikkelverk AS was founded in 1910 and is one of the world's largest nickel refineries with a production capacity of 92 000 tons of nickel. The refinery also produces cobalt, copper, and sulphuric acid. The products from the plant are high purity and used in electronics, jet engines, electrical vehicles, medical equipment's etc. The nickel plant is situated within the city limits of Kristiansand (Norway) about ~1.7 km in distance to the city centre. Kristiansand is Norway's fifth largest town, with a population of ca 110 000 people.

The process at the facility has been developed organically over more than 100 years, making for a very complex plant layout, with many buildings and internal intermediate transportation routes. Figure 1 shows the plant and points to 11 different process units. The raw material is mainly "matte" received in bulk from Glencore operations in Sudbury, Canada, by ships, as well as matte and other intermediates received in 1 ton bags from other suppliers. Matte is a polymetallic sulphide material where Ni, Co, Cu and Fe are the main metals. The raw materials are treated in several hydrometallurgical stages that involves leaching, filtrations, precipitation and electrowinning. Furthermore, they can undergo processing in fluidised bed roasters and melting furnaces. The Ni plant has annual emissions limits to air for Ni (0,75 tons) and for Cu (1,05 tons). The emission permit also regulates total dust, some other gaseous species and more specifications not relevant here. The operating permit covers all defined point sources and diffuse emissions. Diffuse emissions are all sources of dust that are not channelled and captured by a treatment process or come from more mechanical processes outdoors.

The Nikkelverk is the main source to ambient nickel concentrations in the Kristiansand area, which by standard methodology is defined as the Ni concentrations in PM<sub>10</sub> (Particulate matter with an aerodynamic diameter under 10 micrometres). In Norway the air quality norm for Ni concentration is 20 ng/m<sup>3</sup> as an annual average. In 2009 the plant together with Kristiansand municipality started to measure ambient Ni, Cu and Co at one location (No 12 in Figure 1) near the fence line of the plant. The typical yearly average since then have been slightly above the national norm, and the factory has made large efforts and investments to decrease Ni emissions from the plant.

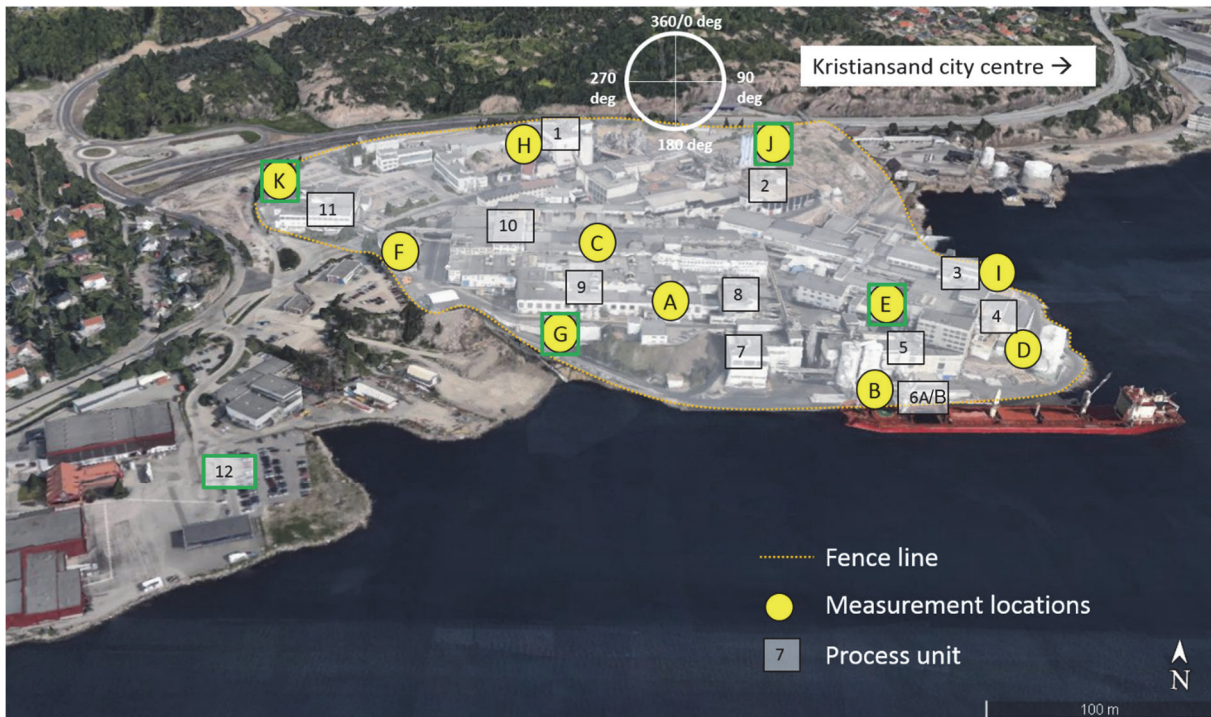

**Figure 1. Aerial overview of the Nickel plant and the surrounding area. The numbers 1-12 refer to some of the different production process units, and the letters refer to sampling and measurement positions (A- K) that have been used within the plant fence lines. Position 12 is the reference measurement site in the national PM network. (The green squares indicate measurements sites that were used for another more in-depth PM study not included here.)**

In order to prioritize further actions and investments an evaluation of the typical contribution of Ni emitted from each process area was needed. Modelling the contributions to the existing fence line monitoring location gave inconclusive and highly uncertain results. More advanced physicochemical analysis, e.g. ICP-MS, ED-XRF, SEM, Raman on randomly picked PM<sub>10</sub> filters from the fence line site also did not provide significant results. The purpose of these additional analyses has been to characterize the nickel compounds in more details, such as sulphates, sulphides, chlorides etc., because they can be linked to different process units. The main problem is sending a collected filter of dust with unknown Ni content to an expensive analysis that could potentially yield no usable results. Thus, often costly analytical work was done with limited practical results.

Multiple and fairly equivalent co-located filters sampled together were needed, to avoid the problem of sending dust filters with low amounts Ni containing dust to advanced physicochemical analysis. Furthermore, the ambient concentration of nickel at most positions within the plant will very much depend on local wind and weather conditions<sup>1</sup>. The samples will thus vary in time based on just weather effects, and a large sampling number is consequently needed. The Ni refinery also needed a sampling device that was easy to place at different sites on the plant, and ground level, on top of the roofs etc. This would give the flexibility to get contribution data from different process units around the plant.

It was therefore decided to construct a new simpler sampling device that could yield more than one sample simultaneously. The idea was to build a sampler that could give order of magnitude data with satisfactory quality for continuous abatement work to reduce Ni emissions. It was also very important that additional chemical analysis could be done on samples taken at the same time and same place on filters we already knew had a significant level of nickel mass. The purpose was not to have a certified reference sampler for legal reporting or perform any absolute contribution calculation from any process unit. Total emission monitoring and reporting according to compliance with operating permits are done independently to this project. Calculating Ni emission factors from diffuse sources is more costly and resource intensive as it requires a much higher time resolution in Ni concentration measurements, meteorological data must be recorded, and reverse dispersion modelling must be used in addition to measurements<sup>2</sup>. It will also require a more detailed approach with respect to TOS to adequately represent the emission sources as diffuse dust sources are very heterogeneous in nature, with regards to composition and concentration levels.

This paper will describe the initial work on making a novel multi-sampling device for PM<sub>10</sub> filters to gain spatially distributed filter sets for post-chemical analysis. We will show some initial data to verify the function of the sampler and disclose some of the pilot results. The sampling device has provided the plant with a smarter and cost-efficient methodology to detect, monitor and document ambient trace metal concentrations within fence lines.

Most ambient Ni concentration studies are done to document air quality outside plant fence lines, deposition to the biota, or inside buildings during occupational hazard studies<sup>3-8</sup>. Not many studies have been conducted to investigate the ambient Ni concentration distribution inside the plant lot. However, a similar study was done for another air pollutant class of compounds, PAHs, inside a steel plant<sup>9</sup>. Other methods of detecting Ni emission "leaks" do not exist, but camera detection can be used qualitatively today for dust and gases<sup>10, 11</sup>.

## Construction requirements and initial operation of new filter sampling unit

Design and construction of the new filter sampling device was focused on several important requirements as follows. The main requirement was that it could filtrate air onto three filters simultaneously that would be fairly identical to be used for parallel physicochemical analyses. The unit should be able to operate for at least 7 days without inspection. Further requirements were that the unit should be easy to transport by a forklift or that two persons could carry it. It should require very little maintenance, also be easy

to dismantle, trouble shoot and require no re-calibration upon doing so. Operators should be able to change filters and adjust device settings with minimal training. Weather shouldn't be a factor for operation, and thus the unit should be able to withstand weather conditions and temperatures in Norway. Several commercial filter types should be able to be used since chemical analysis requires different filter types. Last, the cost should be below approximately 15 000 €.



Figure 2. The sampling device is about 1 m long by 0.40 m tall. The unit can be moved easily with a forklift or manually.



Figure 3. Shows the inside of the box, with the air chamber, flow meter and pump. The wide diameter of the air chamber is large compared to tubes to each sampler, which gives fairly equal airflow through each filter. The flowmeter was calibrated before deployment of the unit.

Design and construction were done in-house at the Nikkelverk. The unit obtains three PM10 filters simultaneously by subjecting Norwegian Institute of Air Research (NILU) standard PM10 filter holders to a constant airflow of 10 lpm (Figure 2). A fourth filter holder was added but has no airflow and provides a blank filter collection set-up. The NILU filter holders consist of a filter holder and an attached PM10 cut-off tube. These are an older type of standard NILU PM10 filter holders that have been configured into the weather-proof box holding the air flow system and pump (Figure 3). The case was made by glass fibre material. The system is light, easily moved with a forklift or by people, and can be placed on the ground or on roofs around the plant site. The initial test runs showed that it could be operated within temperatures ranging from -15C to +25C. Sampling times have varied from 5 – 16 days without significant problems.

## Method development and validation

The goal was to obtain triplet sample sets from many locations inside the plant area. The sample sets could be screened for elevated Ni levels and provide filter copies for advanced chemical analysis when needed. To achieve the Ni screening and to obtain data for investigating the spatial ambient Ni distribution, one has to continuously characterize one filter of each set as the device is moved around. To be able to do this routinely and with manageable cost the nickel plant's own in-house chemical analysis was chosen. The in-house chemical analysis of Ni on PM<sub>10</sub> filters is similar to the European standard NS-EN 14902:2005, where a filter is dissolved in acid, and ICP-MS is used for metals quantification of the solution. The sampling unit was tested with nitrate cellulose filters, pte- filters and quartz fibre filters. All the filter types were found to be usable, however the nitrate cellulose filters were selected for use in further pilot studies since they fit the best with the chemical analysis for metals done routinely at the nickel plant laboratory.

The total weight of PM<sub>10</sub> dust on the filters were not measured as this requires a very resource intensive set-up and is not really impacting the Ni evaluation study. The main reason for this is that Ni mass and PM<sub>10</sub> mass is not highly correlated. In measurements done at the fence (position 12 in Figure 1) Ni was only 0,2% of total PM (measured as 24h filters every 6<sup>th</sup> day over several years) and the linear correlation coefficient was 0,04. The average total PM<sub>10</sub> mass was 12,7 µg/m<sup>3</sup> (Standard deviation: 20,2 µg/m<sup>3</sup>).

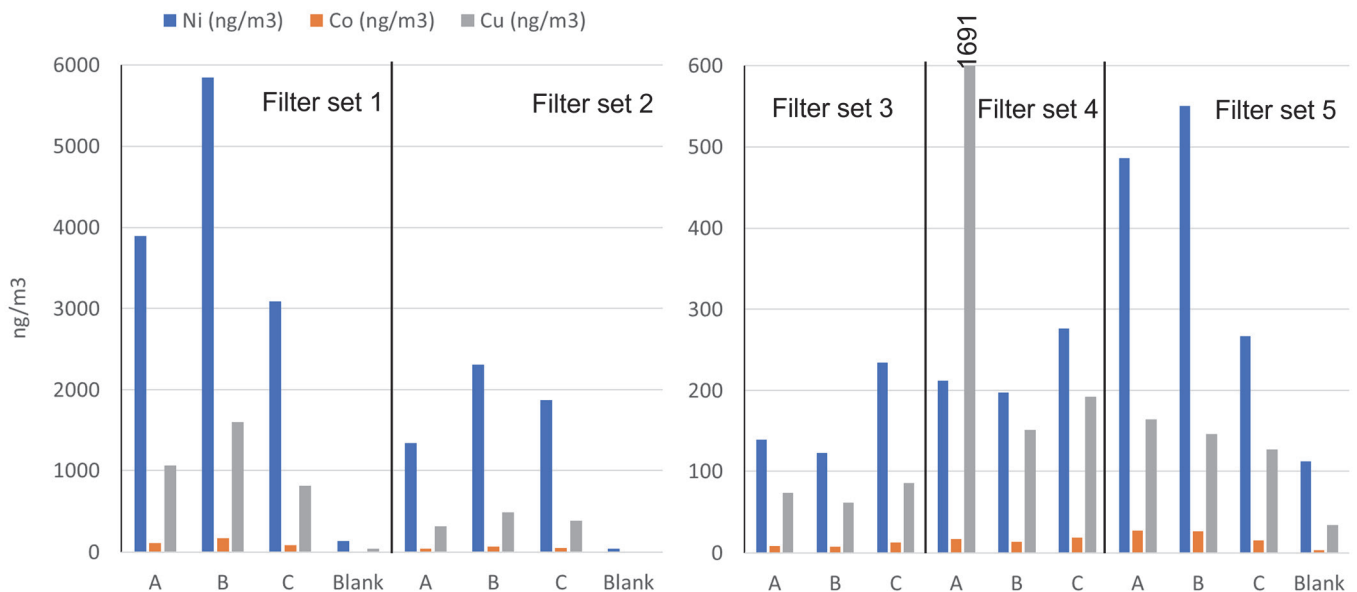

**Figure 4. Overview of data from inter-comparison of Ni, Co and Cu concentrations from 3 filters in five sets of varying Ni mass. The blank is shown for 3 sets. Filter set 4 has one outlier.**

**Table 1. Comparison on two laboratories' analyses of two individual filters for Ni, Cu, Co, and Fe content per filter.**

Metal in PM <sub>10</sub>	In-house (mg)	NILU (mg)	Difference (%)
Ni	0,13	0,125	104 %
Co	0,01	0,006	101 %
Cu	0,05	0,051	108 %
Fe	0,02	0,018	125 %

**Table 2. results from chemical analysis of filter sample sets of varying Ni Content. Average metal concentration in air is showed with the calculated standard deviation also given in percent.**

Sample period	n	Ave. Ni (ng/m <sup>3</sup> )	Std dev. (%)	Ave. Co (ng/m <sup>3</sup> )	Std dev. (%)	Ave. Cu (ng/m <sup>3</sup> )	Std dev. (%)
14.-28. May 2020	2	165	61 (37%)	10	2,5 (26%)	74	12 (16%)
16.-24. April 2020	2	229	42 (18%)	16	2,6 (16%)	678	877 (129%)
8.-14. May 2020	3	435	148 (34 %)	23	6,8 (29%)	145	18 (13%)
17.-24. Oct. 2019	3	4276	1416 (33 %)	124	45 (37%)	1155	399 (35%)
1.-16. Aug. 2019	3	1838	486 (26%)	56	13 (22%)	397	85 (21%)

Two preliminary tests were done to qualify the sampling device and the in-house laboratory for routine Ni screening of each sample set. First, a comparison of two filters by was done. The in-house analysis was compared to a reference laboratory (NILU) for metals in PM<sub>10</sub>. The two filters were from location G in 2016. Second, three filter sets with different Ni content analysed at the in-house laboratory were compared.

The comparative analysis of Ni, Cu, Co, and Fe content on two individual filters from one set analysed by two different laboratories. The agreement for the metals was within 4-21% and deemed good enough for using the in-house chemical analysis as the preferred routine Ni analysis. This is shown in Table 1. Five sets of 3 filters from 2019 and 2020 were used to check filter equivalence. The sets had varying Ni mass and were from a few different locations. Blank subtraction and hours of operations with a constant flow are used in calculating the air concentrations. A standard deviation between 18 to 40% was achieved for Ni concentration across the varying masses. Results for Cu and Co are consistent with Ni results. Table 2 and Figure 4 summarizes these data and results. In comparison, method precision calculated from co-located filter samplers that includes both sampling and chemical analysis error for Ni in the US IMPROVE network was 32% % for a study of PM<sub>2.5</sub> filters<sup>12</sup>. Blanks collected with every set in the new sampling device were examined often and showed results near zero for Ni, Cu and Co (Figure 4).

## Results and discussion

An initial pilot study showed the usefulness of the novel sampling device. The average Ni concentration based on the Ni screening efforts was characterized for 10 measurement locations within the plant lot to evaluate the spatial Ni distribution. The unit was rotated at more than 10 sites within the plant area from 2016 until 2022. The sampling periods were in total 3-8 weeks at each location. Typically, filters were collected for one week at a time. The sites varied from being on the ground and on building rooftops. Some locations were near potential sources, while others were not. The average ambient Ni concentration at measurement locations A – K within the plant area is shown in Figure 5. Location 12 is approximately at sea level, while location J is at the highest point at the plant at about 30 m above sea level to give an idea of the landscape shown in Figure 1. All Ni values presented in the results have been blank corrected. [Figure 5 near here]

Results indicated that especially one region of the factory (sites A through-E) had significantly higher Ni concentrations showing than as measured outside the plant area at location 12. Special consideration is also put on site A in Figure 5, where measured Ni concentration is presented before and after a silo investment done in 2016-2017. The new silo made it possible to directly feed materials instead of through a small indoor heap, which significantly reduced Ni concentrations in the area. This reduction was well documented by the new sampling device, as was the differences between sites across the plant. This type of spatial evaluation has shown to be an integral part of the on-going work to reduce Ni emissions, that hopefully will contribute to lowering the total Ni concentrations in air surrounding the plant.

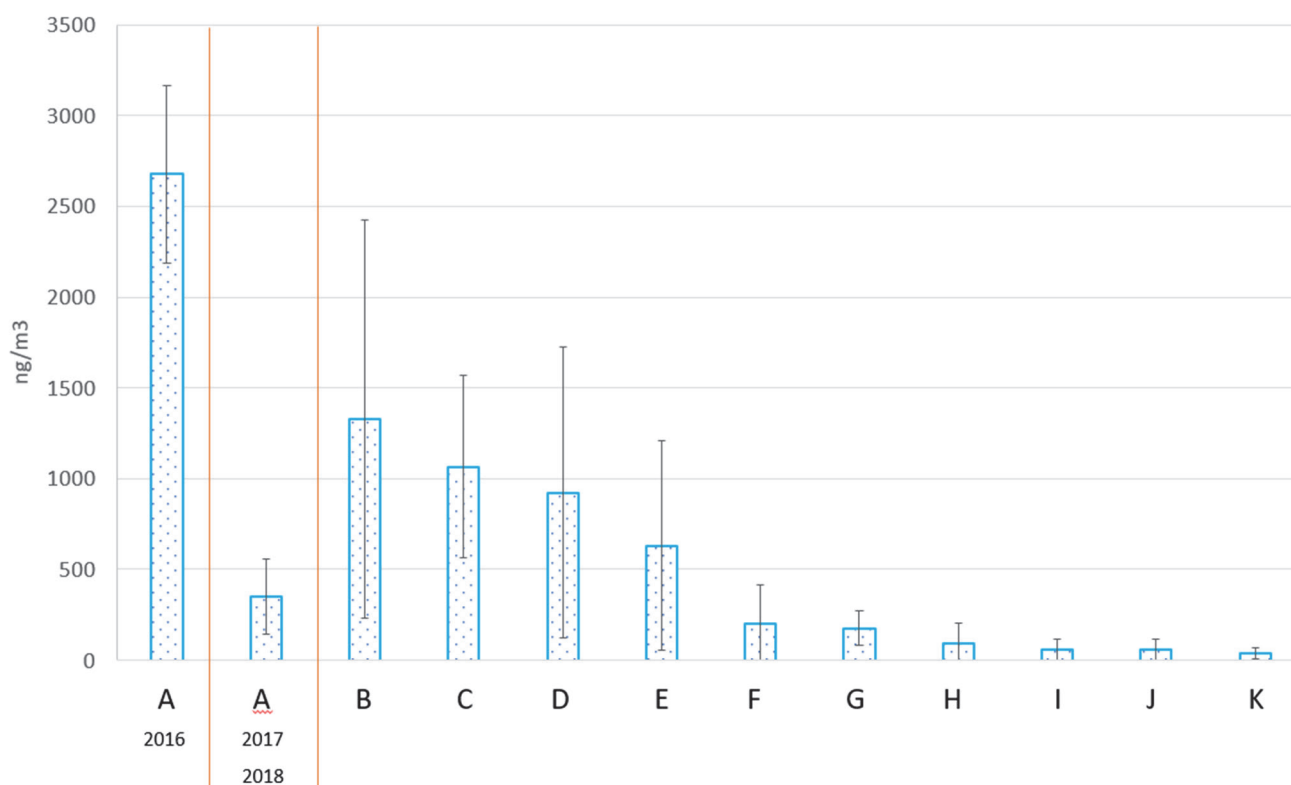

**Figure 5. Average ambient Ni concentration with standard deviation for each measurement location. Two concentrations are given for location A, pre- and post-abatement of one source causing high Ni concentrations in an area.**

## Conclusion

The novel sampling device described in this work provides three equivalent filters that can be used to qualify filters for more extensive and parallel chemical analysis to investigate internal source contributions to ambient Ni concentrations within the plant area. The unit has been shown to operate very well according to all required functions and capabilities.

The Nikkelverk has used the results achieved through in-house Ni analysis of PM<sub>10</sub> filters in combination with process knowledge to do defensible investments that reduce Ni emission. The developed methodology helps to address three problems that inhibit the collection of co-located dust samples: cost, unknown Ni content of in collected dust (as they are not correlated), and

in the mobility of a sampling system for collecting co-located filters. If the methodology is to be developed into emission reporting type framework, a more detailed study with respect to TOS is required. Diffuse emission sources are heterogenous in nature and there is a question whether ambient sampling near sources can properly capture this.

The filter data base is going to be further analysed in a larger investigation into which sources specifically contribute most to the ambient Ni levels within plant fence lines. Samples with high Ni content are undergoing other advanced physicochemical analysis that can disclose specific sources going beyond just finding Ni hot spots. The characterization of the nickel compounds as sulphates, sulphides, chlorides etc. and the actual link to different process units is planned to be published later.

## ORCID iDs

Oluf Bøckman: <https://orcid.org/0000-0002-5918-6079>

Hege Indresand: <https://orcid.org/0000-0002-0757-5515>

## References

1. V. Sanfélix et al., "On the source inversion of fugitive surface layer releases. Part ii. Complex sources", *Atmospheric Environment*. **158**:27-35 (2017)
2. V. Sanfélix et al., "On the source inversion of fugitive surface layer releases. Part i. Model formulation and application to simple sources", *Atmospheric Environment*. **109**:171-177 (2017)
3. K. Kyllönen et al., "Trends and source apportionment of atmospheric heavy metals at a subarctic site during 1996–2018", *Atmospheric Environment*. **236**:117644 (2020)
4. H. Li et al., "A multiregional survey of nickel in outdoor air particulate matter in china: Implication for human exposure", *Chemosphere*. **199**:702-708 (2018)
5. H. Price et al., "Airborne particles in swansea, uk: Their collection and characterization", *Journal of Toxicology and Environmental Health, Part A*. **73**:355-367 (2010)
6. C. Simona et al., "Development of a new sequential extraction procedure of nickel species on workplace airborne particulate matter: Assessing the occupational exposure to carcinogenic metal species", *International Journal of Analytical Chemistry*. (2018)
7. E. Steinnes et al., "Three decades of atmospheric metal deposition in norway as evident from analysis of moss samples", *Science of The Total Environment*. 412-413 (2011)
8. J. Szabó et al., "Ambient concentrations of pm<sub>10</sub>, pm<sub>10</sub>-bound polycyclic aromatic hydrocarbons and heavy metals in an urban site of győr, hungary", *Air Quality, Atmosphere & Health*. **8**:229-241 (2015)
9. V. V. Khaparde et al., "Characterization of polycyclic aromatic hydrocarbons in fugitive pm<sub>10</sub> emissions from an integrated iron and steel plant", *Sci Total Environ*. **562**:155-163 (2016)
10. A. Deschamps et al., "Estimation of aerosol type from airborne hyperspectral data: A new technique designed for industrial plume characterization", *SPIE* (2012).
11. S. Sabbah et al. "Remote sensing of gases by hyperspectral imaging: Results of measurements in the hamburg port area" *SPIE* (2011)
12. N. P. Hyslop and W.H. White, "An evaluation of interagency monitoring of protected visual environments (improve) collocated precision and uncertainty estimates", *Atmospheric Environment*. **42**:2691-2705 (2008)

## The evolution of the mechanically agitated hopper in Anglo American Platinum

Neressa Sukha<sup>a</sup>, Coert Kruger<sup>b</sup> and Ndala Kobe<sup>c</sup>

<sup>a</sup>144 Oxford Road, Rosebank, Johannesburg, South Africa E-mail: neressa.sukha@angloamerican.com

<sup>b</sup>144 Oxford Road, Rosebank, Johannesburg, South Africa E-mail: coert.kruger@angloamerican.com

<sup>c</sup>144 Oxford Road, Rosebank, Johannesburg, South Africa E-mail: ndala.kobe@angloamerican.com

**For Anglo American Platinum (AAP) to reach their burning ambition goal of doubling the Earnings Before Interest, Taxes, Depreciation, and Amortization (EBITDA) by 2023, sites are required to adopt an alternative approach to improve representativeness of metal accounting samples given the increase in grind and throughput demand. The success of optimization projects will rely heavily on metal accounting data being accurate so that improvements declared are based on sound samples and assay measurements. The 60 litre mechanically agitated hopper (MAH) was initially developed and ratified in order to overcome particle segregation evident in the 20-litre conventional, compressed air-agitated hoppers of vezin type sampling systems. A sustained plant accountability performance within the range of 95-105% was realized due to the correction of the previously overstated feed grade by means of a more representative sample. Pierre Gy's rule of thumb of 30 increments per sampling campaign has not been proven and documented for the Platinum Group Metals (PGM) industry. The MAH however with additional volume capacity allows for flexibility to increase the primary sampling increments per shift from  $\pm 32$  to  $\pm 96$  to cater for process variability (thereby reducing distributional heterogeneity) without increasing the overall resulting final sample mass. Additional technology and larger 110/220 litre capacity hoppers have been deployed. Enhancements include a wash water and drainage system, an improved trash screen design and high/low hopper level sensors. The MAH principle of operation has also been expanded to cater for a double (3-drive) stage sampling system as well as a triple (5-drive) stage sampling system. It is believed that the latest MAH design will satisfy the Theory of Sampling principles and therefore a motivation for an industrial roll out of the innovation within AAP is underway.**

### Introduction

A concentrator plant was under-accounting in terms of 4T (Platinum, Palladium, Rhodium and Gold) content in 2015. It was proven that the main reason for the consistent under-accounting was due to the correct sub-sampling of finer, high grade particles and the bias low sub-sampling of the coarser, lower grade particles present in the feed slurry streams into the plant<sup>1</sup>.

Test work was conducted, and this involved a series of experimental studies designed to gain an understanding of the presence and extent of particle segregation in the intermediate hopper of a typical UG2 feed vezin sampling system. A total of three stages of test work were conducted, including vezin credibility and chronological sub-sample tests on a re-designed hopper nozzle and a mechanically agitated hopper.

The tests on sub-sampling of the feed material from the intermediate hopper performed on the original sampling arrangement (Stage 1) demonstrated that segregation occurs in the intermediate hopper of the feed sampling system. A consistent bias was observed between the reject and official samples with the official samples being bias low in coarse particles and being higher in 4T grade than the reject samples. By means of a paired t-test, the calculated bias for % mass retained was deemed significant at the 95% confidence level. This outcome together with the assay by size analysis performed confirmed the under-accounting scenario<sup>1</sup>.

It is believed that the particle segregation which was so evident in the baseline test was significantly reduced with the incorporation of the alternative nozzle design and mechanical agitation. Compressed air agitation alone does not seem to keep all particles of varying size and density in suspension in the intermediate hopper.

The benefits of the mechanically agitated hopper with alternate nozzle design configuration were realized by the concentrator plant and this provided the ideal business case to replace current intermediate hoppers on metal accounting sampling points within concentrator plants with mechanically agitated hoppers to align with current best sampling practice for Anglo American Platinum.

The added benefits of the mechanically agitated hopper include:

- Accommodating sites experiencing issues with grind. With the mechanically agitated hopper, all particles in the primary sample have the same chance to become part of the overall sample i.e., representativeness is ensured. This can be achieved by increasing the trash screen aperture size on top of the hopper as well as the hopper outlet to cater for larger particle sizes as a result of poor grind. Currently, particle build-up is sometimes evident on the hopper screens and are most likely not incorporated in the final sample;



- Pierre Gy's rule of thumb of 30 increments<sup>2</sup> per sampling campaign has not been proven and documented for the PGM industry. The MAH however with additional volume capacity allows for flexibility to increase the primary sampling increments per shift from  $\pm 32$  to  $\pm 96$  to cater for process variability (thereby reducing distributional heterogeneity) without increasing the overall resulting final sample mass. Periodic errors within the process can be factored into the metal accounting to ensure better representability. The process variability can further be assessed via the construction and interpretation of variograms.

In order to reach the burning ambition goal of doubling the EBITDA by 2023, the Anglo American Platinum sites need to adopt an alternative approach to further improve representability of their metal accounting samples. A number of improvement initiatives have thus been facilitated by means of P101 projects. P101 is an Anglo American's asset transformation programme aimed at accomplishing and re-defining industry leading performance in the focus areas to deliver the absolute maximum value from the processing operations. The success of P101 projects will rely heavily on metal accounting data being as accurate so that improvements declared are based on sound samples and assay measurements – the ability to measure better will allow for proactive management. The accountability for a plant is used as a risk management tool to identify issues with mass measurement, plant sampling and analytical tasks. Plant accountabilities being within acceptable ranges will also provide further assurance that other plant performance parameters such as recovery are accurate i.e., it does not make sense to have a recovery of 90% with an accountability of 85% or 140%.

The initial cost or capital outlay for the mechanically agitated hopper is estimated to be in the region of 200 000 ZAR per sampling point. As an illustration, given that two metal accounting points exist, the risk of a parameter such of recovery being inaccurate by  $\pm 1\%$  over a 12-month period for five years amounts to a Net Present Value (NPV) of  $\pm 244$  million ZAR with a payback period of 2 days. It was therefore recommended that the mechanically agitated hoppers be implemented across all metal accounting sampling points to mitigate risk further. Through research, considerable focus has been placed on eliminating particle segregation during primary and secondary stages of sampling by applying rules for Theory of Sampling and sampling correctness<sup>4</sup>, and sample preparation through the correct design of automated and mechanical samplers, and the determination of minimum sample size required. Currently though there is still limited knowledge available regarding segregation of particles in the intermediate hopper of the Vezin sampling system configuration. The success of this work and learnings is being strategically extrapolated to all processing plants that treat and sample material with characteristics that involve grade by particle size associations.

### Technology modifications and alignment to growing business requirements

The novel idea to collect multiple primary increments over a period of time in a day tank and then sub-sample using a secondary sampler was first established at an Anglo-American Platinum Smelter. It was through this initiative that the proof of concept was trailed and tested to allow for further application to other processing sites. As previously mentioned, in order to resolve 4T accountability issues at a concentrator plant, an extension of this novel idea by means of a MAH design was proposed, fabricated, and implemented. Through planned test work, it was shown that collecting more primary increments over a period of time in a hopper and introducing mechanical agitation significantly reduced particle segregation allowing for a more representative sample to that of the bulk stream being sampled to be realized. Following the first design of the MAH, a number of improvements and enhancements as shown in Figure 1 below have been incorporated as a result of collaboration with site personnel and troubleshooting of operational related scenarios.

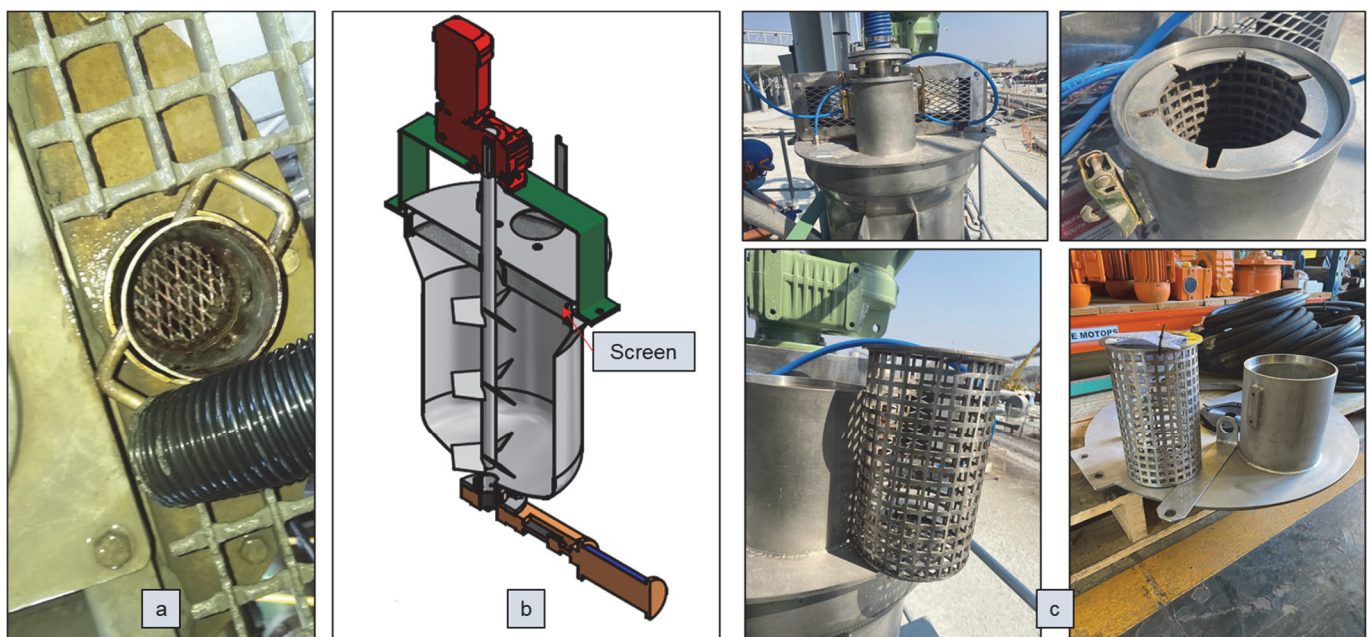

Figure 1. Trash Screen Design – a. Day Tank; b. MAH Original; c. MAH Current.

These include the re-design of the trash screen at the inlet to the MAH for easier removal, inclusion of wash water and a drainage system for housekeeping purposes, larger MAH capacities to cater for increased volumetric flows and hence extension of a double stage sampling system to that of a triple stage sampling system, and engineering controls and interlocks pertaining to level control on the MAH to allow for process variability. The sub-sections below provide further background and detail to the evolution of the MAH design and alignment to the ever-growing business needs in line with the arrival of the fourth industrial revolution.

#### Proof of concept – Day tank Sampling at a smelter

The original idea of collecting multiple, primary increments over a period of time and then sub-sampling through a secondary sampler stemmed from an existing sampling system design and concerns within the Anglo-American Platinum Smelter environment. This sampler design consisted of a primary Vezin sampler, a conventional, air-agitated, intermediate hopper with a float (to control the hopper level) and a secondary sampler with a rotating tube and two stationary cutters to generate an A and B sample<sup>5</sup>. Material would then be sampled per batch as it is transferred from a homogenising tank to a weigh tank on load cells. The sample % solids was then applied to the weigh tank wet mass to obtain a dry mass for the individual batch. All dry batch samples were then prepared in a weighted composite manner in order to obtain a daily lot sample for Platinum Group Metal (PGM) analysis purposes. The sampling and sample preparation of this material was claimed as being labour intensive and time consuming. It was therefore queried whether it would be possible to collect only one sample per day for this material.

Previous investigations had indicated that collecting only one sample from an individual batch and applying the % solids and grade to all the related batch transfers for the day would cause a small error for dry mass (0.17%) but a more substantial error for grade and thus platinum ounces (-2.12%)<sup>5</sup>. The current sampling system design would therefore have to be modified if the workload around sampling and sample preparation were to be reduced. The use of a day tank was then suggested with caution towards careful design of the tank capacity to prevent overflow and thus loss of material for the sampling period as well as to be mindful of settling of solids of varying size and density. If no flushing or water addition is applied and the number of primary increments per batch is reduced (to the minimum of 30 as per Gy's rule of thumb<sup>2</sup>), then all the primary increments for the various batch transfers of the day can be collected in a day tank. At the end of the metal accounting 24-hour period, the contents of the day tank can be sampled with a secondary sampler to generate an A and B sample. It was necessary to investigate and develop a new sampling system that would conform to the Theory of Sampling principles but also be effective (time, resources, cost) in reducing the quantum of samples collected for further sample preparation and allow for a representative sample for metal accounting purposes<sup>6</sup>. A 1m<sup>3</sup> day tank design as seen in Figure 2 was then proposed, fabricated, and installed in parallel to the batch sampling system at the smelter.



Figure 2. Day Tank – a. Oval Tank Design; b. Off Centre Agitator inside Day Tank; c. Sampler Inspection/Safety Grid.

The oval shaped tank design was suggested due to the limited footprint available on site and an off centred agitator had to be installed due to this limitation as well. The new design also catered for safe operation and maintenance of the sampling system and included engineering controls like safety inspection screens for separation of people from moving machinery. Gy's theory of sampling of particulate materials is acknowledged and widespread through various applications. On the contrary, however, Gy's theory of distributional heterogeneity of a material, detailing segregation effects is rarely discussed and is usually ignored in sampling calculations<sup>3</sup>. The day tank design thus included a trash screen as well as an agitator to keep the primary increments homogenized and minimize particle segregation. Through test work and ratification of the new design, it was concluded that the new sampling design provided a daily sample which was representative and unbiased. The new design was then implemented on similar streams at the Smelter.

### The MAH – The double stage sampling design and principle of operation

Depending on the volumetric flow rates presented to the primary sampler, the actual volume of the primary increment, the need to maximise on the  $\pm 96$  primary increments in the MAH, having a fixed reduction ratio (2.5%) of the primary increment presented to the secondary sampler and the need to obtain a 15L sample at the end of a given shift, a single 60L or 110L MAH design has proven to be sufficient in holding a number of primary increments without compromising the primary sample itself. In general, a primary linear-cross stream sampler, MAH and secondary vezin sampler combination can adequately provide a representative sample for metal accounting purposes. The 3-stage sampling system consists of a 3-drive panel. The sampling system can be operated in a manual, automatic or remote (via Programmable Logic Calculator (PLC)) mode. The primary and secondary samplers are driven by a direct on-line electric motor with a reduction gearbox whilst the MAH is powered by a variable speed drive. The primary sampler includes two proximity switches to stop the cutter head outside the bulk stream being sampled once a primary increment is taken. The MAH design as per Figure 3 below includes two level sensors for high and low level in order to compensate for volumetric flow surges. Low level is defined as 30% of the hopper full (effective volume including agitator and internal baffles) capacity and high level (high level sensor is adjustable if need be) is defined as 90% of the hopper full (effective volume including agitator and internal baffles) capacity. The formulation of the 30% MAH level is to keep particles in slurry suspension and minimize residual solids build up over time.



**Figure 3. MAH – Internal and External Views.**

It is vital during commissioning of the MAH that the impellers on the agitator shaft are adjusted accordingly to always ensure one impeller is positioned in the low-level region of 30% but slightly above the hopper discharge point. The MAH comprises an actuated valve at the base of the hopper which is interlocked with the primary increment counter to open and close accordingly thereby initiating secondary sub-sampling or not. At the base of the hopper, an air blowing nozzle is also incorporated together with an air pressure regulator (should be set to minimum requirement as per valve design or application for the MAH). The agitator with the MAH runs continuously to ensure the material contained within the hopper is homogenized at all times. There are a number of engineering interlocks and control features in place to cater for instrument failure (for example, fail safe position for actuated valve is set to open) as well as the principle of operation of the MAH.

The sampling system is designed to stop and indicate a fault on the control panel if any circuit breaker trips on overload however the sampling system will continue to operate and will only show a VSD fault when the VSD trips. If for any reason there is a loss of power to the sampling system and the primary sampler cutter head is not located in the park position, the motor will start immediately and drive the cutter head to one of the two park positions. This has been factored in to prevent the cutter head from being stuck in the bulk stream after a power failure. A sampling operator in the field may empty the system of material at any time and automate flushing of the sampling system by means of pressing a pushbutton in the vicinity of the sampling system.

In summary, taking into account the latest additions to the design and operation of the MAH, the control philosophy typically adopted is as follows when the system is run in automatic mode:

1. A primary cutting interval will be pre-determined and set on the timer within the control panel.
2. A counter as per Figure 4 will be set according to the number of primary increments one would like to collect in the MAH.

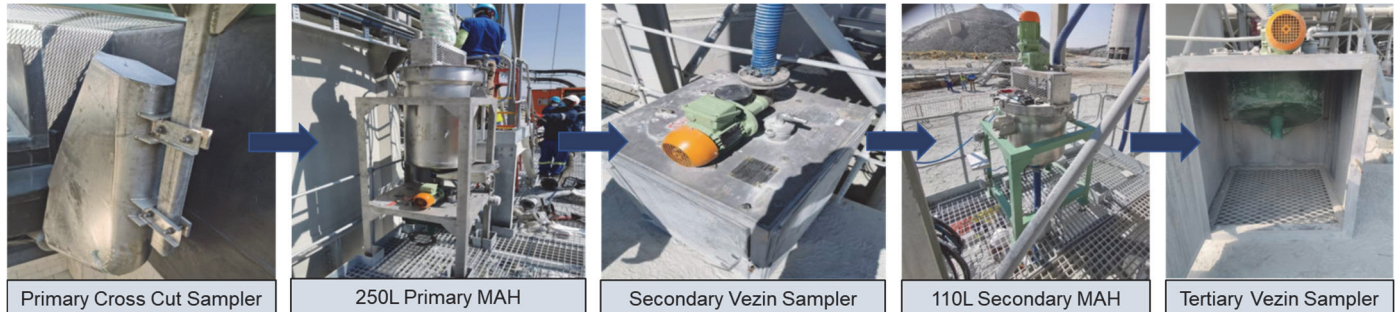

**Figure 4. MAH – Primary Increment Counter(s).**

3. The primary sampler will be parked outside the bulk stream (determined by proximity switches).
4. The proximity switch is activated by a target plate in the park position.
5. The agitator of the MAH will start and continue to run.
6. The secondary sampler will remain stationary (cutters parked outside the stream to be sampled).
7. The primary sampler will take a single increment at the time intervals indicated as per step 1 above. A “bucket full” timer will then start to run upon the first primary increment being taken.
8. The primary increment from step 7 above will be deposited into the MAH.
9. The air to the hopper will be active and the actuated valve at the base of the MAH will be in a closed position.
10. Steps 7 and 8 will continue until the number of primary increments as per counter setting has been reached. However, if the 90% (high level sensor) is reached before this, the hopper valve will open, the air to the hopper will be deactivated and sub-sampling will occur through the secondary sampler. As soon as the valve starts to open, the secondary sampler will start to operate to ensure no material is missed during the initial sub-sampling activity.
11. Sub-sampling of the collected primary increments will then continue via the secondary sampler until the MAH level reaches 30% (low level sensor). At this point, the hopper valve will close and the air to the hopper will be activated again. The secondary sampler will cease to operate after 5 seconds of the valve closing (delay built into the control philosophy again to avoid missing final sub-sampling of material still exiting the hopper). The counter will then reset to 0 and the counting begins again and so does steps 4-11.
12. Should the hopper valve position be open and the primary sampler cutting interval has elapsed, a provision for an interlock is in place to prevent the primary sampler from taking an increment whilst the hopper is in the process of draining to 30% level. However, if the primary sampler was in the process of taking an increment and the 90% increment has been reached, the control will allow for the primary increment to be taken and then proceed to park the primary sampler in park position outside the bulk stream.
13. This process is repeated for the time set on the “bucket full” timer after which it will then stop. The sampling operator then needs to acknowledge the end of shift/sampling campaign, the flushing of the sampling system (MAH and secondary sampler) with water can be activated by means of a push button in the field. All of the residual solids within the system is then given an equal opportunity to form part of the overall sample.
14. A push button located in the field to manually wash or flush the automated wash water system and reset the “bucket full” timer at the same time will activate the wash water system in the MAH whilst immediately resetting the “bucket full” timer. When this button is activated, the MAH will start to drain. A timer will be activated at the 30% full hopper level whilst the MAH will drain, and the secondary sampler is operating. When this timer has reached its setpoint calculated as the time it will take for the hopper to drain from 30% to empty, the wash water will be activated while the MAH valve stays in the open position. The secondary sampler will run continuously so both the MAH and secondary sampler are washed together. The wash water will then continue with the time set on another timer. When this time has elapsed, the wash water will stop, the MAH valve will close, and the secondary sampler will stop. During this wash time, the primary sampler will not be able to take any primary increments.

### The Adaption of the double stage sampling design to a triple stage sampling design

For the more extreme volumetric flow rates, a single 60L or 110L MAH design has proven to be insufficient in holding a number of primary increments without limiting the number of primary increments being collected within the MAH and overflowing the MAH and sample collection buckets. This goes against the original objective of introducing collection of more frequent, multiple increments to cater for distributional heterogeneity. It was thus necessary to design for a 5 stage sampling system viz. primary sampler, primary MAH (250L), secondary sampler, secondary MAH (110L) and tertiary sampler as seen in Figure 5 below.



**Figure 5. MAH – Triple Stage Sampling Design at a Anglo American Platinum Concentrator Plant.**

The principle of operation remains the same as described previously. The washing cycle however will now cater for the primary MAH, secondary sampler, secondary MAH and tertiary sampler configuration.

### Conclusion

The hypothesis that particle segregation is present in the intermediate hopper of a typical UG2 feed sampling system was confirmed at a concentrator plant<sup>1,7</sup>. The 4T accountability at this plant step changed to be within the acceptable limits after incorporation of the MAH and this performance has been sustainable. Pierre Gy's rule of thumb of 30 increments per sampling campaign has not been proven and documented for the PGM industry. The MAH with additional capacity allows for flexibility to reduce the sampling interval even further to cater for process variability and increase the number of the primary increments (thereby reducing distributional heterogeneity) being taken without increasing the resulting overall sample mass. Periodic errors within the process can be factored into the metal accounting, to ensure better representability. The process variability can further be assessed via the construction and interpretation of variograms. Currently, there are five Anglo-American Platinum concentrator plants operating with the MAH technology. It is envisaged that further enhancements will be incorporated into the MAH design as the mining industry as a whole embraces the arrival of the fourth industrial revolution.

### Acknowledgments

GEMA Team, Anglo American Platinum Business Units, Multotec South Africa (Pty) Ltd.

### ORCID iDs

Neressa Sukha: <https://orcid.org/0000-0001-5810-9963>

### References

1. N. Naicker and V. Sibanda, "Particle Segregation associated with Sub-Sampling of Flotation Feed at a UG2 Concentrator", **118**, 57-64 (2017). <http://dx.doi.org/10.17159/2411-9717/2018/v118n1a7>
2. P.M. Gy, *Sampling of Particulate Materials: Theory and Practice*. 2nd Edition, Elsevier Science Ltd., Amsterdam, Netherlands (1982).
3. G.J. Lyman, "The Influence of Segregation of Particulates on Sampling Variance - The Question of Distributional Heterogeneity", 55, 95-112, *International Journal of Mineral Processing* (1998).
4. F. F. Pitard, *Pierre Gy's Sampling Theory and Sampling Practice*. 2nd Edition, CRC Press LLC, USA (1993).
5. E. Le Roux, "Evaluation of Slurry Mass and Volume for Day Tank", (Internal report, no. GEMA-2011-042), Johannesburg, South Africa (2011).
6. P. Qeque, "Day Tank Sampler Ratification", (Internal report, no. GEMA-2015-016), Johannesburg, South Africa (2015).
7. N. Sukha, C. Kruger and W. Slabbert, "Implementation of an Alternative Sampling Protocol at a Typical UG2 Concentrator in South Africa", *Sampling 2018 International Congress for Minerals Sampling*, Lima, Peru (2018).

## Sampling for Industry 4.0 – Sensor signal acquisition inspired by the Theory of Sampling (TOS)

---

M. Lischka<sup>a</sup> and K. Berelsmann<sup>b</sup>

<sup>a</sup>HERZOG Maschinenfabrik GmbH & Co. KG, Auf dem Gehren 1, 49074 Osnabrück, Germany

E-mail: [m.lischka@herzog-maschinenfabrik.de](mailto:m.lischka@herzog-maschinenfabrik.de)

<sup>b</sup>HERZOG Maschinenfabrik GmbH & Co. KG, Auf dem Gehren 1, 49074 Osnabrück, Germany

E-mail: [k.berelsmann@herzog-maschinenfabrik.de](mailto:k.berelsmann@herzog-maschinenfabrik.de)

---

The Theory of Sampling (TOS) has become firmly established in many process industries over the last few decades as the basis for precise and accurate material characterisation. Increasingly, considerations go into the design of sampling and sample preparation equipment to ensure sample representativeness. With the introduction of digitalisation under the buzzword Industry 4.0, many options have emerged to monitor these processes. But also, in the other fields, such as process analytics techniques (PAT) and applied sensor technology, which are not directly attributable to sampling, new applications arise where the Theory of Sampling is never-the-less a very useful addition. Here we present two case studies in which TOS have delivered decisive improvements in data acquisition.

### Introduction

The application of Industry 4.0 approaches has already taken a firm place in many areas of industry that can no longer be imagined without. Not only can predictive maintenance be organized and implemented, but the information obtained can also be used to gain new knowledge about processes and to control them in a targeted manner. Primarily, machine parameters from systems and their components can be read out and evaluated. Here, for example, torque values, acoustic signals, travel times, and temperature can be mentioned and supplemented by many others<sup>1,2,3</sup>. In addition to the information that can be obtained directly, additional sensors and measuring instruments are frequently added in order to obtain a more extensive data density.

When using these methods to produce relevant data, a basic understanding of the measurement process itself is required to record a meaningful representative data series. Process Analytical Techniques (PAT) must be designed specifically for each application so that a sufficiently detailed information density can be used.

Accordingly, each measured and recorded value must be representative. This shows clear parallels to the sampling of raw materials for their analysis, the basis of which has been scientifically anchored in the Theory of Sampling (TOS) for decades and is being used more and more. Nevertheless, the Theory of Sampling is less known in the field of process technology and sensor technology. Here, however, it could play a decisive role.

At this point, not only obvious questions like: "How do I measure, and at which point?" arise, but also far-reaching other issue, such as sampling rate, interference factors, data transport speeds, and measurement uncertainties have to be considered. These and other specific sources of error add up to the Fundamental Sampling Error (FSE) for sensors which, together with the variation of the measured system, defines the total measurement uncertainty (TMU)<sup>4</sup>. There are many similarities between physical sampling and digital sensor signal acquisition.

Below two cases are presented that show how a fundamental understanding of TOS helps to properly design, monitor (QA/QC) and use sensor measurement systems. Both case studies are developed to control sample preparation processes for chemical, mineralogical and physical characterization of raw materials.

### Sample preparation for X-ray fluorescence analysis

X-ray fluorescence (XRF) is one of the dominant measurement techniques for chemical analysis of inorganic substances<sup>5</sup>. In order to enable measurement by this qualitative method, the sample material must be prepared in such a way that these optimal conditions for the analysis is matched in each preparation. Forms of sample preparation are used here:

- Grinding and pressing of the sample material into a steel ring (Case A)
- or chemical digestion at over 1000°C and obtaining a homogeneous glass bead. (Case B).

Both methods require a basic reproducible preparation process to reproduce the initial conditions during calibration of the analytical instrument. Smallest deviations can have consequently negative effects on the measurement result<sup>6</sup>. When grinding and pressing the sample material, the achieved particle size distribution is an important

factor, while in chemical digestion the temperature measurement accuracy plays a major role<sup>7</sup>. To ensure a sufficient reproducibility of those processes, while tool condition monitoring comes to the fore.

## Case A: Measurement on powder

For a direct measurement of the sample material, a grain size must be achieved beforehand which is suitable for the low penetration depths of the X-rays. Particularly for the determination of light elements, grain sizes ideally smaller than  $45\ \mu\text{m}$  must be achieved. So-called vibrating disc mills are often used here to grind the sample material to a correspondingly fine size. This preparation method is subject to a variety of influencing factors that affect the particle fineness achieved and, consequently, the measurement accuracy of the XRF measurement. The use of an acceleration sensor attached to the grinding vessel can provide important information for this purpose. This provides information about the condition of the mill, which is naturally subject to wear, and can reveal variations in the sample material.

### Vibrating disc mill with acceleration monitoring

Due to the unique design of the vibrating disc mills shown in figure 1, a new possibility has arisen to monitor the grinding process completely. The experimental set-up explained below in connection with the applied sensor technology are already protected by patent<sup>8</sup>. The special feature here is the design of the oscillating unit, which is freely supported by springs, and an acceleration sensor fixed to it, which is why the smallest changes during the grinding process can be determined and analysed.

The oscillating unit consists of eight horizontally arranged tension springs and six vertical compression springs, which support and stabilize the movable inner rigid assembly (eccentric drive and grinding vessel). To start the grinding process, the three-phase motor drives an eccentric weight at speeds of 700 to 1500 rotation per minute (rpm), which consequently generates a vibration and transmits it to the grinding vessel. This vibration is directed into a circular path by the symmetrical arrangement of springs, thus ensuring a controlled and uniform grinding process. The grinding is performed by a grinding ring and stone inside the grinding vessel. The two grinding tools are accelerated by the circular oscillation and roll against the grinding vessel wall, crushing the sample material. In grinding with the vibrating disc mill, the comminution mechanisms of compressive, shear and impact stress are mainly effective<sup>9</sup>. Thus, this principle enables reliable and fast grinding of medium-hard, hard, brittle or fibrous materials to particle sizes below  $45\ \mu\text{m}$  and, at the same time, realization of the highest standard in avoiding contamination of the subsequent sample.

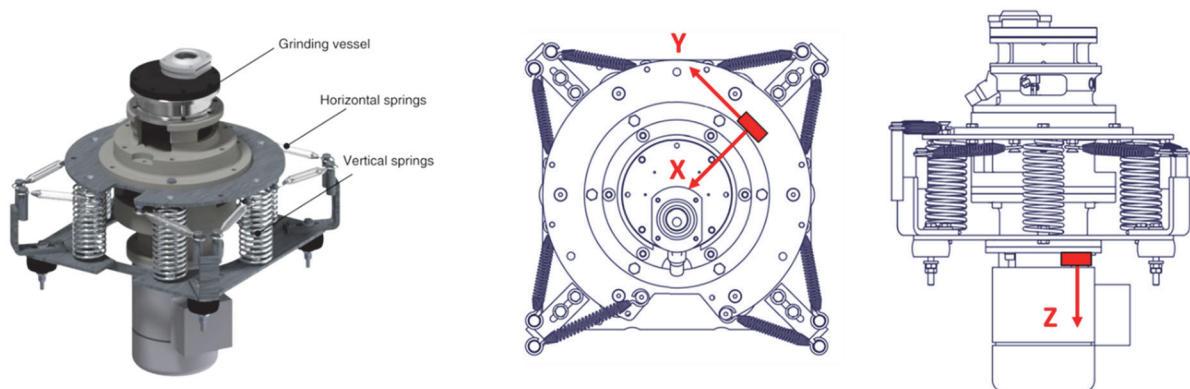

**Figure 1: Swing aggregate of a vibratory disc mill with horizontal and vertical springs guiding the motion of the grinding vessel<sup>10</sup>.**

Many investigations have shown that not only changes in the mechanical components (wear of tension and compression springs, wear of the grinding set or motor settings), but also the specific properties of the material have a significant and characteristic influence on the vibration of the system. Therefore, to monitor the grinding process, a tri-axial capacitive accelerometer is fixed to the motor flange. The exact mounting position of the acceleration sensor on the vibrating disc mill is shown in figure 2. The sensor is mounted concentrically so that the X-axis points in the direction of the centre of the vibrating unit. To record the acceleration data, the data is read out and evaluated in real time. For the sampling rate of the measurement data, 100 values per second were specified.

In the following, two critical error potentials of the sensor-based monitoring of this oscillating unit are presented and how the application of TOS can assist in their avoidance.

### Importance of a suitable position of the accelerometer

Imprecise location of accelerometer. A wrong sampling method (sampling location, execution, material quantity, sampling frequency) is known to influence the significance and accuracy of the subsequent analysis. The same is also the case for sensor technology as applied to the vibrating disc mill, where many factors (including the choice of sensor, recording frequency, positioning of the sensor) must be considered. Just as with TOS, it is important to identify the correct location or position for sample or data acquisition during acceleration measurement prior to subsequent analysis. Here, the more complex the process, the more difficult and important this decision is.

Due to the manifold and partly also random influencing factors on the vibration behavior of the vibrating aggregate, such as: Starting position of grinding ring and grinding stone in the grinding vessel (influences start-up behavior), filling weight of the material, grain size of the material, temperature, speed, grinding aids, etc., a high degree of complexity is given for this application. Therefore, instead of the actual direct investigation of grinding processes, the determination of a suitable sensor position was dealt with first, in order to be able to fall back on reliable and valid measurement data subsequently.

By considering the vibration to be expected theoretically and checking possible sensor positions in practice, the position shown in figure 1 was determined as the reference position. It became clear that the positioning of the sensor (i.e., the removal of the sample) plays a fundamental role. This is impressively shown by the two acceleration measurements in figure 2. The diagram shows the acceleration data in the X and Y coordinate system of two identical sensors during the same no-load operation at a speed of 1400 rpm, only located differently.

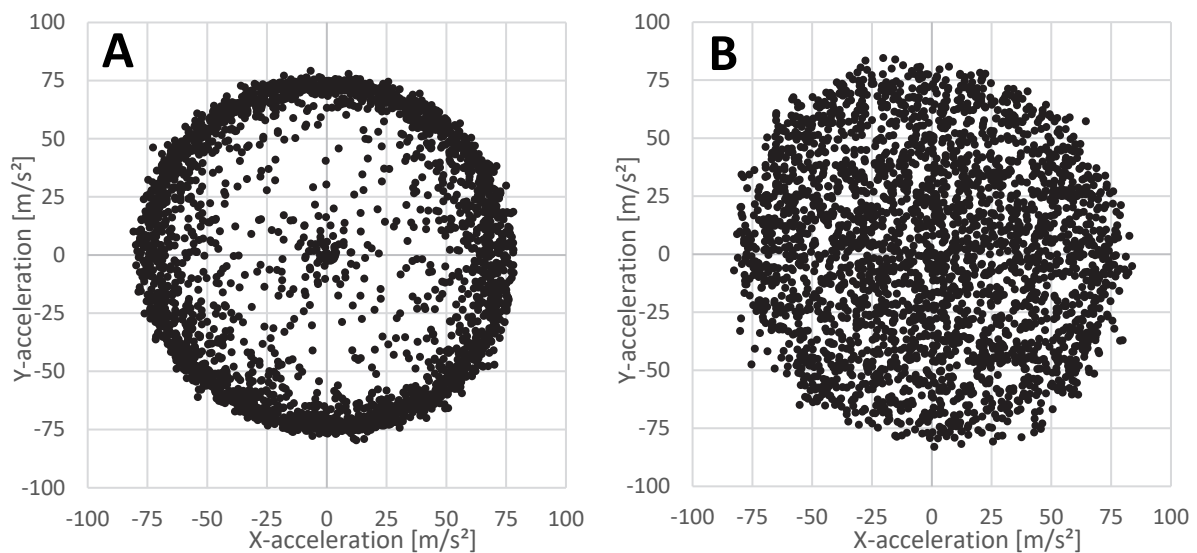

**Figure 2: Measurement of acceleration in x- and y-axis at an unloaded milling run with 1400 rpm with sensor in (A) suitable measuring position according to figure 1 and in (B) unsuitable measuring position (near an attachment point of a horizontal spring) to evaluate the concentricity of the disc mill<sup>10</sup>.**

Based on the theoretical consideration of the oscillation system, an ideal circular path of the system is to be expected during an idle run, (free movement of the grinding stone and ring without the grinding of material). However, due to the tumbling behavior of the spring-loaded grinding vessel, not every position is suitable for mounting the sensor to detect this circular motion. In position A (at the motor flange), the expected circular motion including the partial deviations can be seen very clearly. This is contrasted by the recorded measurement data (B) from the sensor position at the attachment point of the tension springs. Although a circular motion can also be guessed there, this can by no means be described as uniform and makes a detailed statement about the condition of the oscillating unit in comparison with the theoretical reference value difficult or impossible. The deviating measurement data from sensor position (B) are, in addition to the tumbling behavior of the oscillating unit, probably also generated by the spatial proximity to the grinding vessel, since impact and shock movements of the grinding set additionally have an influence on the measurements of the acceleration data.

With position (A) a suitable sensor position was found for this application, which can realize an accurate monitoring of the grinding process. This is demonstrated in the following section on a practical example for potential benefits of a tool monitoring system.

It should be noted that the sensor must always be mounted in the same fixed orientation (position and inclination), otherwise there is no comparability between grinding processes. Even small angles or changes in direction influence the recording of the acceleration data, so that the potential statement of the TCM system about the condition of the



vibrating unit would be subject to error. Therefore, one should also follow one of the principles of TOS and implement a constant control of the sampling or data recording, since the greatest error occurs at this point in the process.

In data acquisition, as in sampling, the principles of TOS apply: the method must always be precisely adapted to the particular application, otherwise errors may occur, which may propagate to an error in the subsequent analysis.

### Selection of the sampling rate

While in the case of sampling from a lot or from a material stream, attention must be paid to the frequency of material sampling to obtain a result that is as representative as possible. The question of the sensor's sampling rate is indispensable in the case of sensor condition monitoring. For both cases it is true that an incorrect methodology at this point will most likely have a significant impact on the analysis result (measurement result of the XRF or condition monitoring of the TCM system).

To illustrate the importance of this check, two variants for the choice of sampling rate are presented and evaluated below. For this purpose, two idle runs were performed at 1400 rpm and the acceleration was recorded in the first step with the standardized sampling rate of 100 Hz and in the second step with 23.3 Hz, which approximately corresponds to the excitation oscillation of 23.3 Hz.

The investigation includes the analysis of the vibration in the X-direction. For this purpose, the measured data points of the X-acceleration for both sampling rates were first plotted against the grinding time. Subsequently, a sinusoidal curve representing the ideal acceleration curve for a uniform vibration was added. The ideal acceleration curve thereby approximately describes the vibration behaviour in the so-called idle state.

The general form of the sine curve contains some parameters which change the course of the graph with regard to certain characteristics.

$$A(t) = A_0 * \sin(2\pi * T * (t + \varphi))$$

Where:

- $A_0$ : Amplitude of the oscillation [  $m/s^2$  ]
- T: period duration [s]
- $\varphi$ : phase shift [s]
- t: time [s]

This sinusoidal curve and the measured acceleration values can be used to demonstrate why the "sampling parameters" should be precisely matched to the application and checked before evaluation/analysis.

The effects of an incorrectly selected sampling rate can already be seen in the graphical representation of the measurement data on the vibration curve. In comparison with the idealized vibration in no-load operation, the sampling rate can be immediately identified as the source of the error, but usually only statistical data, as shown for this example in the following table, are available for evaluation or analysis.

**Table 01.: Statistical evaluation of the measurement data with the sampling rates 100 Hz (A) and 23.3 Hz (B.)**

	Fig. A	Fig. B
Sampling rate	100 Hz	23.3 Hz
Number of data points	51	12
Standard deviation	51.6 $m/s^2$	0 $m/s^2$
Average acceleration	0.5 $m/s^2$	-25 $m/s^2$

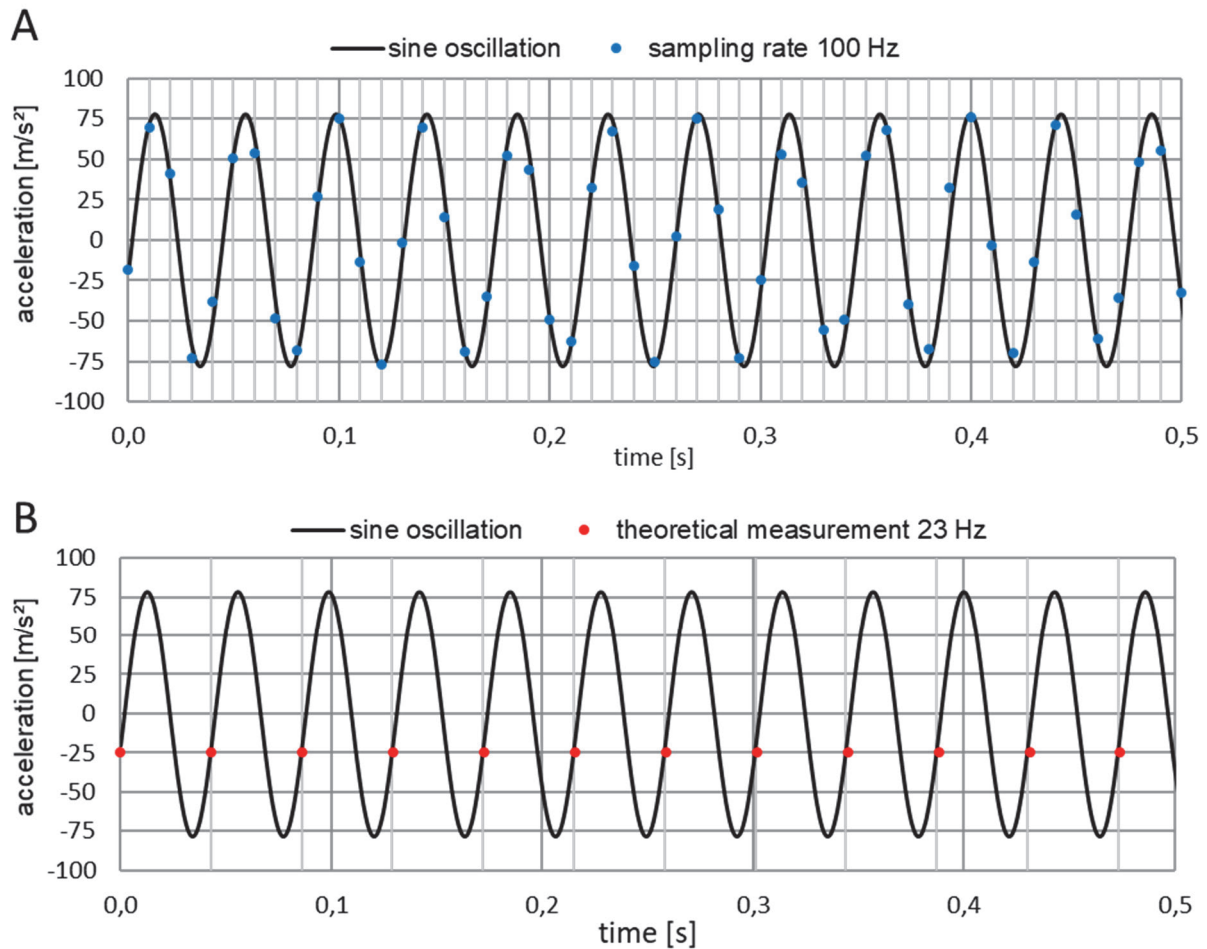

**Figure 3: Display of the measured values for acceleration in the X-direction for an idle run with approximated sinusoidal oscillation with a sampling rate of (A) 100 Hz and (B) 23.3 Hz over a time range of 0.5 seconds.**

On the basis of the static values, one can see an opposite course, although the acceleration or oscillation is actually identical. While the statistical values of figure A are approximately representative of the present oscillation (mean value of all acceleration must be 0  $\text{m/s}^2$  for circular movements), the values from figure B indicate a constant acceleration of -25  $\text{m/s}^2$  and thus manifestly not a circular movement.

To avoid this misinterpretation, the principle of sampling frequency (sampling theorem) must always be considered before using a sensor. The Shannon-Nyquist theorem states that the sampling frequency must be greater than twice the fundamental frequency of the sensor so that the fundamental frequency can be measured correctly<sup>11</sup>. At the present maximum speed of 1500 rpm, this results in a fundamental frequency of 25 Hz for which the sampling theorem is satisfied.

Also, for this point of consideration of the data acquisition at a vibrating disc mill, a consideration of the basic principles of TOS can support in error prevention. It is always important to increase the significance of a measurement as much as possible.

#### Practical example for potential benefits of a tool monitoring system

With a representative and detailed measuring system, the movement path of the grinding vessel can thus be continuously monitored. To guarantee an optimum service life for the mill, this data can be used for predictive maintenance. The following data set of six recorded runs of the mill clearly shows how data analysis can help predict machine failures, such as in this case caused by a cracked motor flange anchor bolt. The first signs of developing damage were evident five days before the actual event. Ideally, the X/Y vector of acceleration should reflect the relatively stable circular path of the grinding vessel (Graph 4 A). Slight deviations from the ideal condition can already be seen here. Nevertheless, not as clearly as they become visible in graph 4 B. Here the acceleration values show two pronounced negative anomalies, which are opposite each other on the circular path. Over the next few days, the acceleration drop at these two positions increased and the oscillation behaviour of the grinding vessel

was more and more disturbed by the speed changes. The reduced power transfer due to the slowly loosening motor from the grinding vessel also impacted the achieved particles size distribution of the material to be pulverized. The material was not ground sufficiently which would have had significant consequences for accuracy and precision of the subsequent analysis.

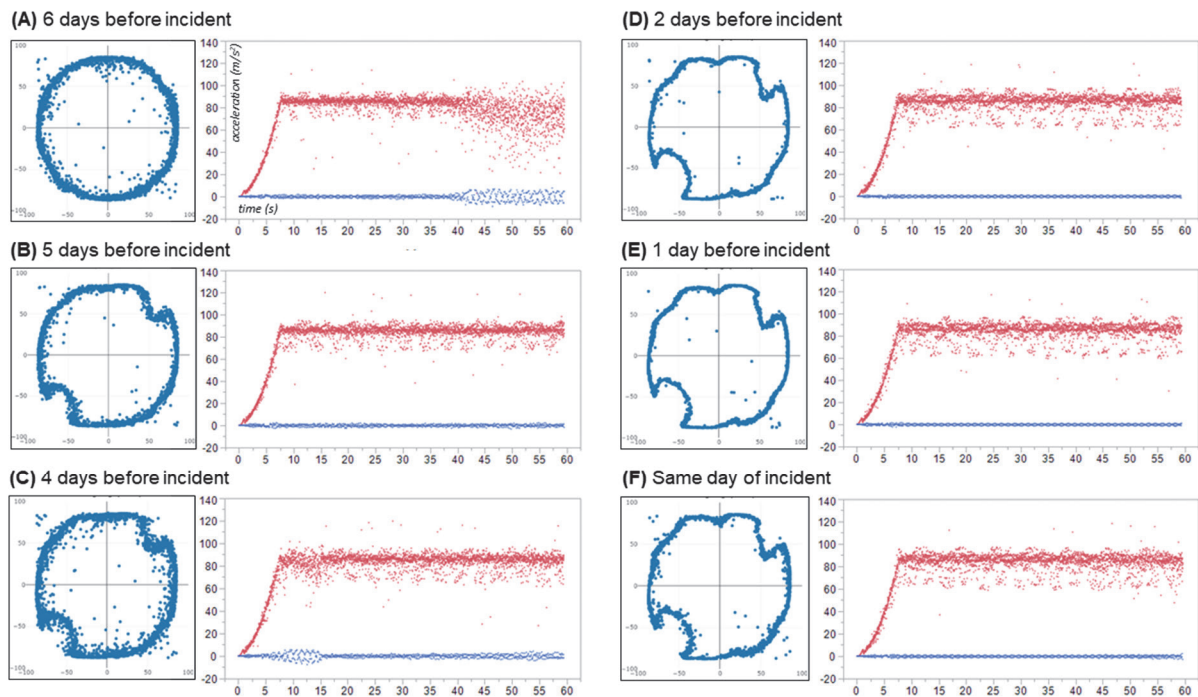

**Figure 4: Display of acceleration x-y- vectors (left box) and RMS values (red dots, right box) in the period before incident with breakage of anchor bolts between drive motor and swing aggregate. Six days before (A) only small deviations in the acceleration could be observed. In the subsequent period of time (B-F) a significant progressive deviation occurred.**

When the anchor bolt finally broke off, there was a direct loss of velocity of almost 50% (see figure 5). With the acceleration curves recorded, it is now possible to interpret these anomalies using statistical methods. This data set can be used in the future to inform personnel that an inspection and, if necessary, precautionary maintenance must be carried out. With these measures, machine failures can be effectively avoided and a high availability of the system can be realized.

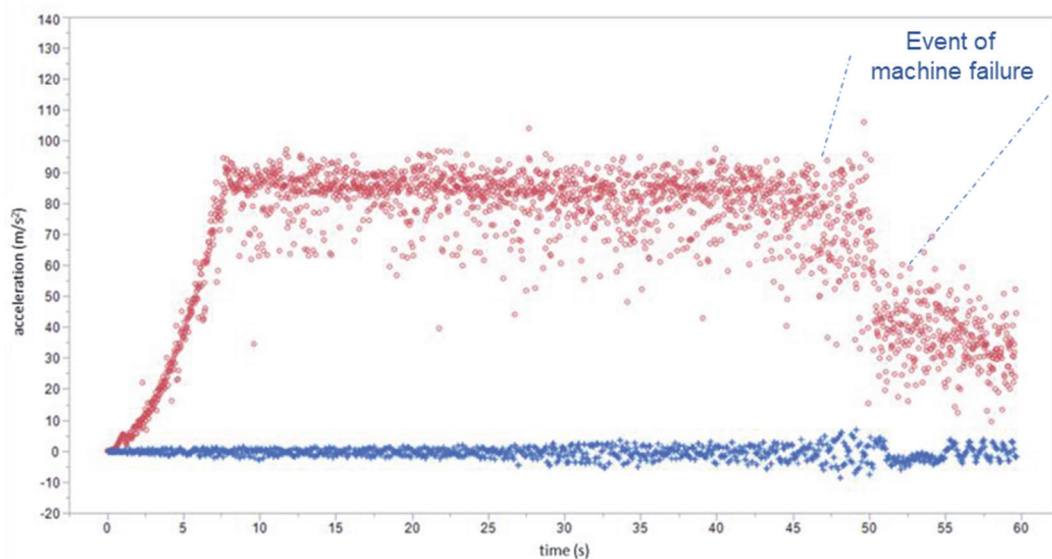

**Figure 5: Display of the RMS of the x-y- acceleration (red dots) and z-acceleration (blue dots) showing the breakage of the anchor bolts.**

## Case B: Measurement of a borate glass

The chemical digestion of the sample material in a lithium borate has many analytical advantages and creates, among other things, a matrix-independent sample preparation<sup>12</sup>. In a fixed mixing ratio, glass former/flux and sample material are digested for several minutes at over 1000°C, homogenized, and then poured into a dish. Three different heating methods are used here in laboratories, electric resistance furnaces, gas burners or induction digestion units, to heat the platinum/gold crucible (95% Pt/5% Au) to the desired temperature. For classical applications (electric/gas), thermocouples can be used for direct temperature measurement, providing good temperature resolution. For more complex digestion methods, where different temperature levels are required during fusion, induction heating is particularly suitable because the temperature control can be adjusted with almost complete flexibility. This is due to fast heating and cooling rates. Those fusion methods also tend to be sluggish and maintenance prone due to the corrosive vapours of the chemicals often used in the process where induction heating is much more reliable compared to other heating methods. The disadvantage of this heating method is that temperature control during digestion can only be performed indirectly via infrared pyrometers and strongly depends on a well-known emissivity of the measured Pt/Au crucible.

### Methodology

A general setup of the fusion unit is shown in figure 6 and the characteristic values of the infrared pyrometer used are summarized in table 2. The pyrometer measures the thermal radiation emitted by the crucible and computes the temperature with

$$T = \sqrt[4]{\frac{P}{\varepsilon \times \sigma \times A}}$$

Where  $T$  is the temperature [K],  $P$  is the total radiated power [W],  $\varepsilon$  is the emissivity,  $\sigma$  is the Stefan-Boltzmann constant [ $\text{W m}^{-2} \text{K}^{-4}$ ] and  $A$  is the area [ $\text{m}^2$ ]. The only unknown variable is the emissivity, which for platinum depends on the surface condition and temperature.

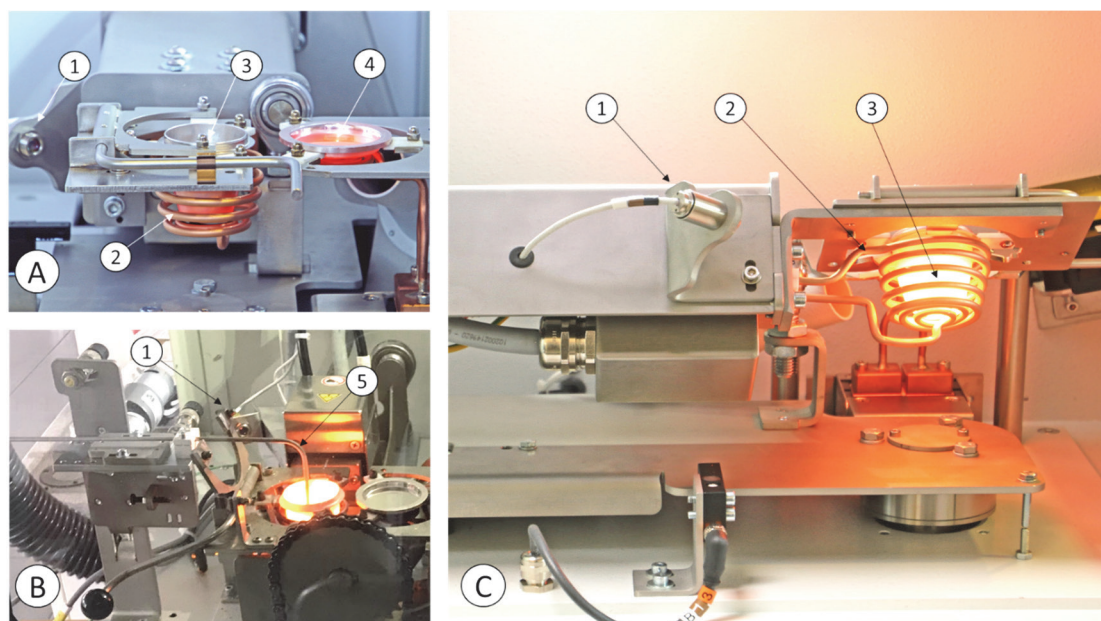

**Figure 6: Induction heating unit with:**

- (1) IR pyrometer**
- (2) Induction coil**
- (3) Pt/Au crucible**
- (4) Pt/Au casting dish**
- (5) Thermocouple for calibration.**

In order to allow temperature calibration and determine the emissivity ( $\varepsilon$ ), a patented methodology has been developed, which allows the emissivity of the crucible to be determined indirectly from the temperature of the melt<sup>13</sup>. Here, a NiCr/Ni thermocouple (see table 2) is positioned in the borate melt and the emissivity is adjusted by an algorithm until the pyrometer reading matches that of the melt. In this way, a specific emissivity can be assigned to each crucible used. To account for the additional temperature dependence of emissivity, calibration is performed

at two (or four) temperature levels, taking into account the fusion temperature range used in the specific method to be applied.

**Table 2: Main features of the used IR pyrometer used for process control and the K-Typ thermocouple used during the temperature calibration of the IR pyrometer.**

IR pyrometer crucible - 1MH Used for process control		K-Typ thermocouple SCAXL-125U-6-SHX Used for calibration	
Temp. range:	650-1800°C	Type:	NiCr/Ni
Spectral range:	1 μm	Temperature range:	0-1145°C
Optical resolution:	75:1	Uncertainty:	2,2°C or 0,0075 x T <sub>m</sub>
Accuracy:	± 0.3% T +2°C		
Reproducibility:	± 0.1 % T+1°C		
Resolution:	0.1°C		
Detection time:	1 ms		

Once the emissivity's ( $\varepsilon_i, \varepsilon_j$ ) for both temperatures ( $T_i, T_j$ ) have been determined by the control system, a linear equation can be drawn up which shows the relationship between emissivity and temperature. For a more precise calibration the regression can be extended to four temperatures used for calibration.

The general term for the linear equation with  $\varepsilon$  on the Y-axis and T on the x-axis is

$$\varepsilon = m T + b .$$

The following applies to the emissivity and temperature pairs  $\{(T_i|\varepsilon_i), (T_j|\varepsilon_j)\}$ . The slope  $m_{ij}$  of the linear regression line is

$$m_{ij} = \frac{\varepsilon_j - \varepsilon_i}{T_j - T_i} .$$

The y-axis intercepts  $b_i$  or  $b_j$  are defined by

$$\begin{aligned} b_i &= \varepsilon_i - m_{ij} T_i , \\ b_j &= \varepsilon_j - m_{ij} T_j . \end{aligned}$$

The emissivity  $\varepsilon_\theta$  of a target temperature  $\theta$  is calculated by

$$\varepsilon_\theta = \frac{\varepsilon_j - \varepsilon_i}{T_j - T_i} \theta + \left( \varepsilon_i - \frac{\varepsilon_j - \varepsilon_i}{T_j - T_i} T_i \right) \equiv \frac{-\varepsilon_j T_i + \varepsilon_j \theta + \varepsilon_i T_j - \varepsilon_i \theta}{T_j - T_i} .$$

Even the emissivity can be determined using this method, but there still remains other factors that can impact accuracy and precision during the fusion process.

With the aim of achieving a temperature accuracy of +/- 5°C, the measurement system was investigated further in numerous measurement series and multiple sources of error were identified:

- Dependence of the emissivity on the crucible surface and the measured temperature, which changes during the life cycle of the platinum crucible.
- Positioning/orientation of the crucible in its holder.

#### Time dependence of surface heterogeneity

The heterogeneity of the platinum crucible surface can be attributed to various reasons and increases during a life cycle. The constant exposure of the material to high temperatures leads to grain growth in the Pt/Au matrix<sup>14</sup>. In addition, during melting, chemical reaction between sample material and crucible may occur, especially when the samples contain so-called platinum poisons or reduced phases<sup>15</sup>. Depending on the initial surface properties the emissivity decreases. The aging rate is therefore dependant on the sample material, digestion method and crucible composition<sup>16</sup>. Additionally, a higher wearing rate can be observed new crucibles at the beginning of their usage. Accordingly, this defines the recalibration interval to ensure a representative measurement over the entire life cycle (see figure 7). To keep the calibration effort as low as possible, characteristic data (e.g. frequency and energy from the high-frequency generator) can be read out from the high-frequency generators in order to monitor the condition of the measurement system via statistical process control.

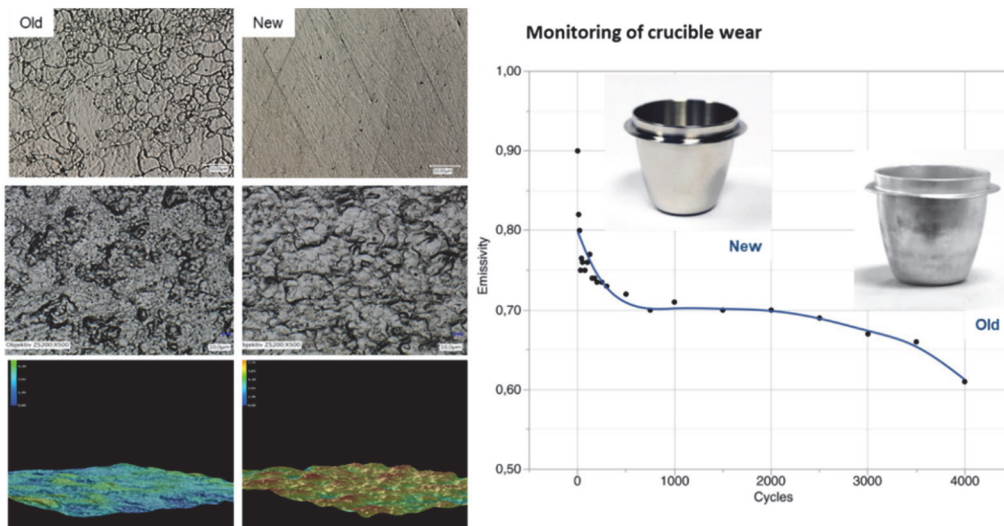

**Figure 7: Change of the emissivity of the crucible surface over 4000 heating cycles. Where reactions in the Pt/Au matrix leading to matrix alteration and changes in the surface roughness.**

#### Addressing in-situ surface heterogeneity

In addition to the aging of the crucible, the positioning of the crucible in the digestion unit also plays a decisive role for the measurement accuracy. Especially after a certain period of use, the crucible surface shows extensive heterogeneity resulting in a broad variation of the emissivity. Depending on how the crucible is positioned, this results in sometimes considerable differences in emissivity and thus in the temperature that drives the control system. Figure 8 shows an example of the typical temperature variation for an old crucible. For the data series, the crucible was rotated  $360^\circ$  twice over in  $10^\circ$  increments, and the temperature of the melt was determined at constant emissivity ( $\epsilon = 0.556$ ) and introduced energy (22%).

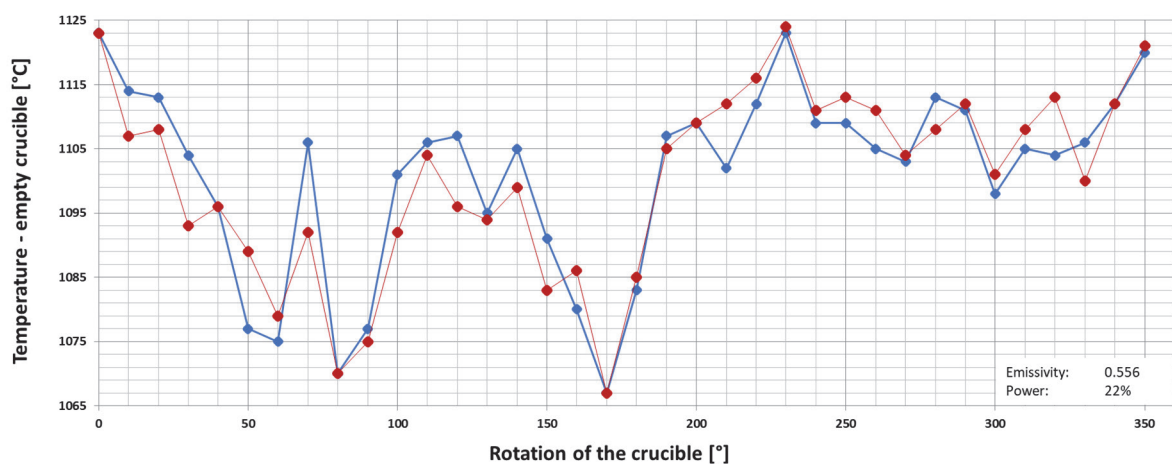
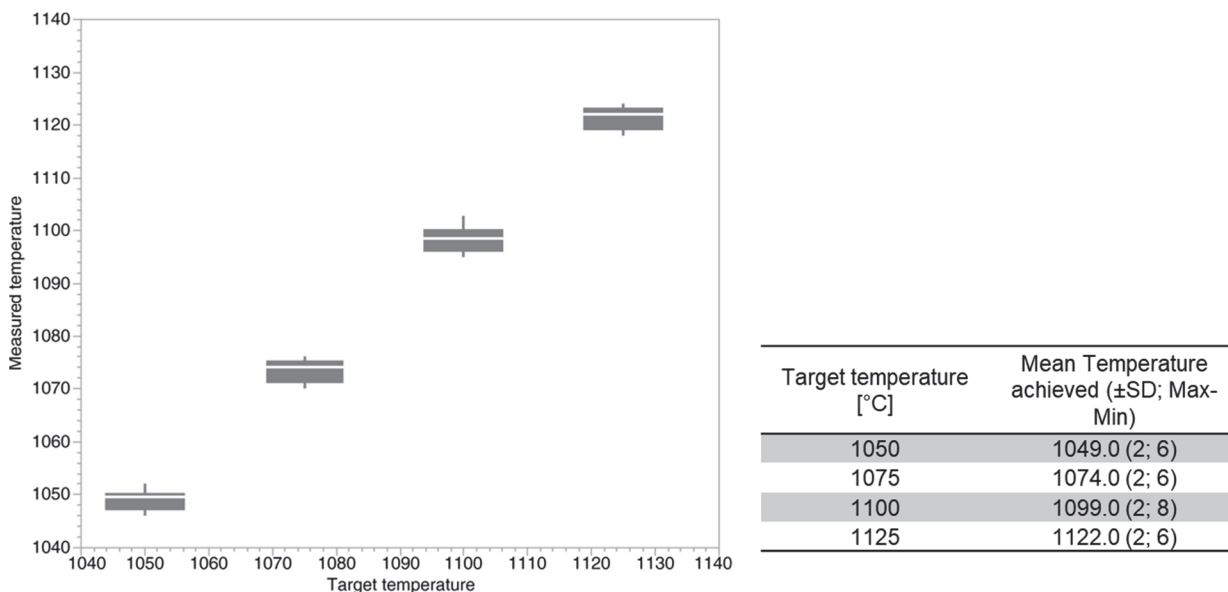

**Figure 8: Measured temperature variance for an old often used Pt/Au crucible heated with fixed emissivity ( $\epsilon = 0.556$ ) and energy (22%). The crucible was rotated in  $10^\circ$  intervals completing  $360^\circ$  twice.**

In order to minimize the fluctuations of the emissivity over the crucible surface, a solution had to be found that positions the crucible as precisely and repeatably as possible in the digestion unit. In benchtop units, this is done manually by the operator, who uses markings on the crucible and digestion unit. For automated systems in which industrial robots are used to place the crucible, camera systems can be used for alignment. The bottom of the crucible is provided with a marking that can be used by the camera system to determine the exact orientation of the crucible. With this angle information, the robot can approach each crucible individually in such a way that, after it has been set down, the temperature is always determined at the same point on the crucible.

### Measuring system accuracy

Taking into account the above-mentioned sources of error in the measuring system and the resulting measures, these factors can be successfully reduced to a large extent. This has been proved in a replication experiment, where the temperature calibration has been checked 20-times for each temperature that has been used in the linear regression (see figure 9). The mean temperatures recorded show a standard deviation of only  $\pm 2^\circ \text{K}$ .



**Figure 9: Temperature precision and accuracy for a four-point calibration, checked by a 20-fold replication test. The mean temperature has a standard deviation of  $\pm 2^\circ \text{K}$ .**

### Conclusion

The two case studies from the sample preparation field for material characterization clearly show how sensor technology and machine performance indicators can help to monitor processes and obtain additional information on the process. The design of the measuring system and its recalibration interval play a decisive role in ensuring that the measured values obtained are indeed representative of the process and/or guarantee its long-term stability.

Considering case A, it becomes clear that when monitoring motion or, equivalently, vibration, the sampling rate must be synchronized with its frequency. Likewise, the optimal positioning of the sensor must be very precisely defined in order to eliminate interference and overlapping as far as possible. Case B, on the other hand, exemplifies the necessity of how the surface properties of the object under consideration play an important role in indirect measurement methods. These can vary at different stages of the process or change over time and require constant monitoring and recalibration. In both cases, the accuracy and repeatability of the measurement systems could be significantly improved using the theoretical approaches of representative sampling or recording of data.

The evaluation of the acquired data can contribute in two ways. First and foremost, the measurement series are used for process control and its monitoring in order to ensure high reproducibility. Furthermore, the same data can be used to give an indirect statement about the reproducibility of the sample preparation. Deviations in the measurement series, for example due to the constitutional and distributional heterogeneity of the sample material, can thus be detected and interpreted. Deviations thus provide additional value to the actual analysis and can also provide direct information about the sample material or be used as a quality proxy in process control.

### ORCID iDs

M. Lischka <https://orcid.org/0000-0001-7259-0079>

K. Berelsmann <https://orcid.org/0000-0003-0711-9875>

The investigations presented here originate from a variety of studies and measurement series carried out as part of bachelor's and master's theses, as well as work-study activities. Therefore, we would like to thank namely Mr. O. Bakoa Job, Mr. W. Heck, Dr. J. Herzog, Mr. S. Jansen, Mr. M. Marks & Mr. A. Mehling.

## References

1. Ambhore N., Kamble D., Chinchankar S., Wayal V., Tool Condition Monitoring System: A Review, *Materials Today: Proceedings*, Volume 2, Issues 4–5, 3419-3428, (2015). <https://doi.org/10.1016/j.matpr.2015.07.317>.
2. Esbensen, K. H. & Julius, L. P., Representative Sampling, Data Quality, Validation –A Necessary Trinity in Chemometrics, 1-20 (2009).
3. Lischka, Martin & Mehling, André. (2020). High-resolution PAT monitoring of sample preparation grinding by accelerometer sensors: the key to ensuring accuracy and long-term consistency. *TOS Forum*. 2020. 35. <http://dx.doi.org/10.1255/tosf.125>
4. Esbensen, K. H. & Paasch-Mortensen, P., Process Sampling: Theory of Sampling -the missing link in Process Analytical Technologies (PAT) Process Analytical Technology (2009).
5. Grieken, R. E. V. & Markowicz, A. A., *Handbook of X-Ray Spectrometry*, Marcel Dekker Inc. (2001) ISBN: 0-8247-0600-5
6. Demir, F.; Simsek, Ö.; Buda, G. & Karabulut, A., Effect on Particle Size to Emitted X-Ray Intensity in Pellet Cement Sample Analyzed with WDXRF Spectrometer, *Instrumentation Science & Technology*, **36**, 410-419 (2013). <https://doi.org/10.1080/10739140802151689>
7. Loubser, M., Chemical and physical aspects of Lithium borate fusion, University of Pretoria, University of Pretoria, (2009). <https://repository.up.ac.za/bitstream/handle/2263/29114/dissertation.pdf?sequence=1&isAllowed=y>
8. Herzog Maschinenfabrik. Scheibenschwingmühle mit Sensorik. EP 3 772 377 A1 Europäische Patentanmeldung (2016)
9. Pyda, W., Theory and Practice of Ceramic Processes. AGH University of Science and Technology. [Online] (2011). [Accessed 13.03.2021]
10. Berelsmann, K. Conception of a software module for real-time monitoring of grinding processes based on acceleration measurements; Hochschule Osnabrück (2021).
11. Arvid Trapp A., Hoesch Q., Wolfsteiner P., Effects of insufficient sampling on counting algorithms in vibration fatigue, *Procedia Structural Integrity*, **38**, 260-270 (2022). <https://doi.org/10.1016/j.prostr.2022.03.027>
12. Nakayama, K. & Nakamura, T., Calibration standards using chemical reagents for glass bead x-ray fluorescence analyses of geochemical samples, *X-ray Spectrometry*, **37**, 204-209, (2008). <https://doi.org/10.1002/xrs.1042>
13. Herzog Maschinenfabrik. Schmelztemperaturmessvorrichtung für eine Aufschlussvorrichtung. EP 3 767 263 A1 (2021)
14. Lupton, D., Merker, J. & Schölz, F., Zur korrekten Verwendung von Platin in RFA-Labors, 5. *Anwendertreffen Röntgenfluoreszenz- und Funkenemissionsspektrometrie*, 1-17 (1998).
15. Saylor, C. P.; Wichers, E. & Hoffman, J. I., Observation of Surface Changes in Platinum Crucibles *Journal of Research of the National Institute of Standards and Technology*, **84**, 385-394 (1979). <https://doi.org/10.6028/jres.084.019>
16. Heywood, A. & Benedek, R., Dispersion Strengthened Gold-Platinum, *Platinum Metal Review*, **26**, 98-104 (1982). <https://www.technology.matthey.com/wp-content/uploads/pdf/pmr-v26-i3-098-104.pdf>





## The Ongoing Challenge of Representative Sampling of Bulk Mineral Commodities

Ralph J Holmes  
E-mail: ralph.holmes@csiro.au

**Sampling of bulk mineral commodities for international trade, such as iron ore, coal and a wide variety of mineral concentrates, is generally carried out in accordance with National or more commonly International (ISO) Standards developed to provide representative samples for subsequent analysis and payment. Because commercial transactions are involved, clearly getting the sampling right is critically important, and poor sampling practices can potentially lead to substantial financial losses for one of the parties involved. The “golden rule” for correct sampling is that “all parts of the material being sampled must have an equal probability of being collected and becoming part of the final sample for analysis”. If this rule is not respected, then bias is easily introduced and samples are not representative.**

**While on-site observations indicate that the adoption of good sampling practices is improving, ensuring that samples are representative continues to be an ongoing challenge. This is often due to cost-cutting measures where sampling facilities, equipment and operations are the first to suffer, or it may just simply be due to ignorance of the requirements for collecting representative samples despite the existence of National and International Standards as well as high level sampling courses presented by international experts. More often than not, the company focus is on maximizing production tonnage rather than product quality and its measurement. Areas where significant issues continue to occur include:**

- **Primary cutter design for ever increasing high-capacity streams**
- **Correct operation of cross-stream secondary cutters**
- **Crusher performance and ongoing maintenance, particularly in relation to product particle size**
- **Retained sample mass versus particle size**
- **Extraction and handling of moisture samples**
- **Equipment maintenance.**

**Timely ongoing maintenance of sample stations is critical and needs to be a high priority to ensure correct performance. A “set and forget” strategy simply does not work. Sampling needs to be given the commitment it deserves by company management, particularly through correct sample plant design, timely equipment maintenance, and appropriate staff training and awareness.**

### Introduction

The accurate sampling of bulk mineral commodities, such as iron ore, coal and a wide variety of mineral concentrates, is critically important where commodities are changing hands between trading parties. The sampling is generally carried out in accordance with National or more commonly International (ISO) Standards that are designed to provide representative samples for subsequent analysis and payment. Unfortunately, poor sampling practices can lead to substantial financial losses for one of the parties involved, so clearly such practices need to be avoided. The “golden rule” for correct sampling is that “all parts of the material being sampled must have an equal probability of being collected and becoming part of the final sample for analysis” (Gy, 1982a and 1982b; Pitard, 1993, 2005 and 2019; Holmes, 2004, 2005, 2007, 2010, 2013, 2015, 2017 and 2019). If this rule is not observed, bias is easily introduced and the samples collected are not representative. Even a relatively small bias can have significant economic consequences (Holmes, 2021), and no amount of replicate analysis of the material collected will eliminate the bias once bias is present.

While the adoption of good sampling practices in the mineral industry continues to improve, representative sampling of mineral commodities remains an ongoing challenge. This is often due to cost-cutting measures where sampling facilities and procedures are the first to suffer and second-rate facilities end up being constructed. Alternatively, the cause may be a poor knowledge of representative sampling requirements by those charged with designing, constructing and operating sampling facilities despite the existence of National and International Standards as well as high level sampling courses presented by international experts. All too often the main driving force is maximizing the production tonnage rather than product quality and its measurement. Areas where significant issues occur usually include primary cutter design for high-capacity streams, correct operation of cross-stream secondary cutters, crusher performance, retained sample mass, extraction and handling of moisture samples, and overall equipment maintenance. Clearly, sampling needs to be given the commitment it deserves by company management through correct sample plant design, timely equipment maintenance, and appropriate staff training and awareness.

The best sampling location for mineral commodities is at a transfer point between conveyor belts (Holmes, 2017 and 2019), where the full cross-section of the stream can be conveniently intercepted at regular intervals, enabling representative samples to be obtained. However, it is impossible to take a representative sample in-situ from a stockpile (see Figure 1) or a ship, because it is impossible to gain access to the material in the centre of the stockpile or deeper within the hold of the ship. In these two cases, samples must be taken while stockpiles are being built up or broken down, or while ships are being loaded or unloaded.



**Figure 1. Sampling from the side of a stockpile is problematic and will not provide a representative sample.**

After satisfying the above requirements for correct sampling, attention then needs to be given to the following important sampling principles (Holmes, 2019):

- Collecting sample masses that are large enough taking into account the particle size to reduce the fundamental, grouping and segregation errors (Gy, 1982a; Pitard, 1993 and 2019) to acceptable levels.
- Taking a sufficient number of primary increments to reduce the long-range quality fluctuation error to an acceptable level.
- Selecting sampling locations that avoid the presence of periodic variations in quality, eg, due to equipment items such as bucket wheel reclaimers and centrifugal pumps.
- Eliminating accessory errors, such as sample contamination, sample spillage (see Figure 2), particle degradation and operator mistakes.



**Figure 2. Accessory errors such as sample loss due to holes in chutes need to be eliminated.**

### Primary cutter design and operation

Extraction of primary increments by the primary cutter in a sample station is the first step in obtaining representative samples from mineral commodities. Consequently, the design and operation of the primary cutter is critical, the key requirements being to ensure correct increment delimitation and increment extraction (Gy, 1982a; Pitard, 1993 and 2019). The requirements for primary cutter design and operation are summarised in the relevant National and International Standards for mineral commodities. For example, the general requirements for iron ore largely taken from ISO 3082 (Iron ores – Sampling and sample preparation procedures) are as follows:

- There shall be no overflow or spillage of sample or loss of ultra-fines.
- There shall be no impedance to flow of sample material through the sample cutter at the maximum flow rate.
- Bucket-type cutters shall be of sufficient capacity to accommodate the increment mass obtained at the maximum flow rate without any sample loss.
- There shall be no clogging or retention of residual material in the sample cutter, i.e. the cutter shall be self-clearing.

- There shall be no contamination or introduction of material other than the sample into the sample cutter.
- There shall be no significant change of the quality of the sample while taking increments, e.g. degradation of the constituent particles if the sample is taken for size determination or change in moisture content if the sample is taken for moisture determination.
- The sample cutter shall take a complete cross-section of the stream, both the leading and trailing edges clearing the stream in one path.
- The sample cutter shall intersect the stream either in a plane perpendicular to or along an arc normal to the mean trajectory of the stream.
- The sample cutter shall travel through the stream at a uniform speed, not deviating by more than  $\pm 5\%$  at any point.
- The geometry of the cutter aperture shall be such that the cutting time at each point in the stream is equal, not deviating by more than  $\pm 5\%$ , e.g. straight-path cutters shall have parallel cutter lips and rotary cutters shall have radial cutter lips.
- The plane of the cutter aperture shall not be vertical or near vertical to avoid sample loss from particles striking the inside edge of the cutter aperture and bouncing downwards to reject.

Expanding on a number of key aspects in the above list, the following requirements are essential to ensuring correct increment delimitation and increment extraction (Holmes, 2019):

- The sample cutter must take a complete cross-section of the process stream with both the leading and trailing edges of the cutter completely clearing the stream at the end of each traverse.
- The length of the cutter aperture must be large enough to intercept all of the material in the stream, including particles bouncing off the inside edges of the cutter aperture.
- The cutting time at each point in stream must be equal. Flap or diverter type cutters do not respect this condition.
- The cutter must travel through the stream at a uniform speed, subject to a maximum cutter speed of 0.6 m/s, accelerating up to its cutting speed before entering the stream and decelerating to a stop only after leaving the stream.
- The cutter must have sufficient power for its duty. Electric cutter drives are best, although hydraulic drives are acceptable if well maintained. Pneumatic cutter drives are not satisfactory, because it is very difficult to maintain constant cutter speed while traversing the stream.
- Belt scrapings should fall within the area traversed by the cutter.
- The sample cutter must be non-restrictive and self-clearing, discharging completely each increment without any reflux, overflow or hang-up in the cutter aperture. Hence, the cutter body should be large and streamlined in design to eliminate reflux at high flow rates.
- The cutter aperture must be at least three times the nominal top size ( $d$ ) of the material being sampled, i.e.  $3d$  to prevent preferential loss of the larger particles, subject to a minimum of 10 mm for dry solids.

The main problems often observed with primary cutters in sampling facilities operating in the minerals industry are failure to take a complete cross-section of the stream, undersized cutter apertures, excessive cutter speed, and sample reflux from cutter apertures at the ever-increasing flow rates encountered in industry. An example of a poorly designed primary cutter that does not correctly take a complete cross-section of the stream is shown in Figure 3 (Holmes, 2019). The primary cutter pivots around an axis on the side of the conveyor belt and hence the cutting time at each point in the stream is not equal, leading to potential bias. This problem does not occur when full cross-stream primary cutters are installed.



**Figure 3. Poorly designed primary cutter that pivots around an axis on the side of the conveyor belt, so the cutting time at each point in the stream is not equal.**

As already indicated above, sample reflux from the primary cutter aperture can be a significant problem at high flow rates (typically greater than 10,000 t/hr), particularly for fine products that have a tendency to hang up in the cutter aperture especially when they are slightly moist. This is evident in Figure 4, where massive sample reflux from the top of the primary cutter aperture and hence sample loss is clearly visible. The solution is to redesign the primary cutter to provide a much larger cutter body and capacity able to accommodate large primary increments, with a sloping rear section that directs the incoming sample down the sample delivery chute and away from the incoming sample material, thereby eliminating sample reflux. A well-designed primary cutter conforming to these requirements is shown in Figure 5. The end result is a primary cutter that is able to correctly sample high-capacity streams without sample reflux as shown in Figure 6.



**Figure 4. Sample reflux from a poorly designed primary cutter with a narrow body and limited sample capacity.**



**Figure 5. Well-designed primary cutter with a large body for sampling high-capacity streams without reflux from the cutter aperture.**



**Figure 6. Sampling a high-capacity stream with a well dimensioned primary cutter displaying no sample reflux.**

### Operation of cross-stream secondary cutters

Another common ongoing problem in sampling bulk mineral commodities is the operation of the secondary cutter, which often is a cross-stream cutter (see Figure 7). The relevant ISO Standards specify the minimum number of secondary cuts (or increments) to be taken for division of primary increments to a suitable mass for subsequent preparation, which commonly is specified as follows:

- A minimum of 4 cuts for mass-basis sampling where constant mass division is required.
- A minimum of 5 cuts for increments of average mass for time-basis sampling where proportional division is required.

It is essential that the cuts taken by the secondary cutter are spread over the entire primary increment to be divided. However, due to incorrect timing of the secondary cuts, unfortunately it is quite common to see substantial sections of the primary increment feed stream totally ignored after the minimum number of cuts has been taken, which clearly is totally unacceptable and likely to introduce significant bias. Equally bad, only one or two cuts may be taken from the primary increment, once again due to incorrect timing between the secondary cutter operation and the feeding of primary increments to the secondary cutter. Getting the operation of the secondary sampling stage right requires special attention and should not pose too many difficulties given the engineering control systems that are now readily available.



**Figure 7. Cross-stream secondary cutter designed to collect separate increments for chemical/moisture analysis and sizing.**

### Crusher performance and retained sample mass

Crushers are very often key equipment items in sample stations for mineral commodities, particularly for lump products where particle size reduction is required to enable sample masses to be safely reduced to facilitate subsequent sample

preparation while keeping the fundamental error variance under control (Gy, 1982a; Pitard, 1993, 2019). The relevant ISO Standards contain tables specifying the minimum mass of samples for this purpose, an example of which is given in Table 1 for iron ores. Similar tables are provided in ISO 13909-2 for coal and ISO 12743 for copper, lead, zinc and nickel concentrates. Sampling regimes are designed around these tables, all of which rely on the crushers installed in sample stations performing their required duty. However, sadly this is not always the case and many instances are observed in operating sample stations where crusher products are much coarser than the design specification due to wear of crusher components and poor maintenance. This is illustrated in Figure 8 where the crusher product is meant to be less than 10 mm nominal top size, but unfortunately it is more like 20 mm or more, which has a big impact on the minimum sample mass that needs to be retained and hence the overall precision of sampling. Clearly this is not acceptable, so crushers in sample stations need special attention and adequate resources need to be devoted to performance checks and maintenance to ensure that crusher products meet particle size requirements in the design of the sample station. More specifically, regular crusher checks are required and crusher gaps need to be adjusted and/or the crushers overhauled to maintain performance.

**Table 1. Minimum mass of divided gross sample for iron ore.**

Nominal top size (mm)	Minimum mass of divided gross sample (kg)	
	$\sigma_D = 0.1\% \text{ Fe}$	$\sigma_D = 0.05\% \text{ Fe}$
40	325	1,300
31.5	180	710
22.4	75	300
10	10	40
6.3	3.2	13
2.8	0.5	1.7
$\leq 1.4$	0.5	0.5



**Figure 8. Nominal top size check of crusher product in a sample station. In this case the target nominal top size of 10 mm was not achieved.**

## Moisture samples

Extraction of moisture samples for bulk commodities is particularly problematic. Unlike chemical analyses which do not change during the sampling process (unless for example a sample is overheated when it is pulverised prior to analysis which may change its chemical composition), significant changes in moisture content can occur in moisture samples during sampling, sub-sampling and storage prior to moisture determination. Consequently, it is vital that moisture samples are extracted quickly with the minimum number of sampling stages, collected in sealed containers, and preferably returned to the laboratory immediately for determination of moisture content. Tricking a moisture sample through a multi-stage sample plant with lots of exposure to ambient air must be avoided at all cost. Notwithstanding these precautions, inevitably some change in moisture content will almost certainly occur and a common practice is to apply a correction factor to compensate for the measured change in moisture content determined for individual sample plants.

## Equipment maintenance and precision checks

The maintenance of sampling facilities is critical and needs to be given high priority and management commitment to ensure correct performance. A “set and forget” approach simply does not work. Unfortunately, many examples of poor maintenance continue to be found in key sampling installations for determining the value of bulk mineral commodities at the point of sale, including worn cutter lips (see Figure 9), partially blocked primary cutter chutes (see Figure 10), sample build-up in secondary cutter apertures (see Figure 11), blockages of Vezin cutter apertures (see Figure 12) and sample spillage and

sample loss. Fixing such problems is not technically complex, but requires strong management commitment to conducting regular inspections of sampling equipment and rectifying identified problems in a timely manner. In more detail, key items that need to be checked include:

- Size and geometry of cutter apertures, including checking that cutters intercept the complete stream.
- Cutter speed and uniformity while cutting the ore stream.
- Condition of cutter lips, including wear and missing cutter lips.
- Build-up and/or blockages in cutter apertures and chutes.
- Reflux from cutter apertures, particularly at high flow rates and for fine moist material.
- Ingress of extraneous material when the cutter is parked.
- Location of belt scrapers and whether scrapings are sampled.
- Increment and sample mass.
- Number of primary, secondary, tertiary increments, etc.
- Holes in cutters, chutes and bins resulting in sample loss.
- Crusher performance, particularly product particle size.
- Condition of vibratory feeders.
- Sample mass as a function of nominal top size at each sampling and sample preparation stage.



**Figure 9.** Primary cutter showing signs of significant wear of the cutter lips.



**Figure 10.** Partially blocked primary cutter chute.





**Figure 11. Sample build-up in the secondary cutter apertures.**



**Figure 12. Partially blocked cutter aperture in a Vezin divider.**

Finally, it is highly desirable to regularly check the sampling, sample preparation and measurement precisions actually achieved in practice, which can be determined using duplicate “interleaved” sampling, e.g. using ISO 3085. If necessary, action can then be taken to address the largest contribution(s) to the overall variance and hence optimise the sampling regime.

## Conclusion

Accurate sampling of bulk mineral commodities, such as iron ore, coal and a wide variety of mineral concentrates, is critically important when commodities are changing hands between trading parties, because poor sampling practices can lead to substantial financial losses for one of the parties involved. The “golden rule” for correct sampling is that “all parts of the material being sampled must have an equal probability of being collected and becoming part of the final sample for analysis”. If this rule is not observed, bias is easily introduced and the samples collected are not representative.

While the adoption of good sampling practices in the mineral industry continues to improve, representative sampling of mineral commodities is an ongoing challenge due to either cost-cutting measures where sampling facilities and procedures are the first to suffer or a poor knowledge of representative sampling requirements by those charged with designing, constructing and operating sampling facilities. This occurs despite the existence of National and International Standards, as well as high level sampling courses presented by international experts. Often the main driving force is maximizing production tonnes rather than product quality and its measurement. Areas where significant issues occur usually include primary cutter design for high-capacity streams, correct operation of cross-stream secondary cutters, crusher performance, retained sample mass, extraction and handling of moisture samples, and timely equipment maintenance. It is essential that

sampling is given the management commitment it deserves through correct sample plant design, timely equipment maintenance, and appropriate staff training and awareness.

## References

- Gy, P M, 1982a. *Sampling of Particulate Materials - Theory and Practice*, 2<sup>nd</sup> Edition (Elsevier: Amsterdam).
- Gy, P M, 1982b. Sampling from high capacity streams, in *Proceedings First Australian International Bulk Materials Conference*, Sydney, Australia, pp 407-423.
- Holmes, R J, 2004. Correct sampling and measurement – The foundation of metallurgical accounting, *Chemometrics and Intelligent Laboratory Systems*, **74**: 71-83.
- Holmes, R J, 2005. Design of sample plants – Getting it right first time, in *Proceedings Second World Conference on Sampling and Blending (WCSB2)*, Sunshine Coast, Australia, pp.103-110 (The Australasian Institute of Mining and Metallurgy: Melbourne).
- Holmes, R J, 2007. Best practice in sampling iron ore, in *Proceedings Third World Conference on Sampling and Blending (WCSB3)*, Porto Alegre, Brazil, pp.
- Holmes, R J, 2010. Sampling mineral commodities – the good, the bad, and the ugly, *Journal of the Southern African Institute of Mining and Metallurgy*, **110**: 1-8.
- Holmes, R J, 2013. The importance of sampling in the mineral industry, in *Proceedings Metallurgical Plant Design and Operating Strategies (MetPlant 2013)*, July 2013, Perth, Australia, pp. 34-49.
- Holmes, R J, 2015. Sample station design and operation, in *Proceedings Seventh World Conference on Sampling and Blending (WCSB7)*, June 2015, Bordeaux, France, TOS Forum, Issue 5, pp. 119-128.
- Holmes, R J, 2017. Common pitfalls in sampling iron ore, in *Proceedings Eighth World Conference on Sampling and Blending (WCSB8)*, May 2017, Perth, Australia, pp. 261-264 (The Australasian Institute of Mining and Metallurgy: Melbourne).
- Holmes, R J, 2019. Best practice in sampling iron ore shipments, in *Proceedings Ninth World Conference on Sampling and Blending (WCSB9)*, May 2019, Beijing, China, pp. 51-62.
- Holmes, R, 2021. Incorrect sampling practices always have significant economic consequences – and never more so than where tonnages are large, *Spectroscopy Europe*, Vol 33, No 6, 84.
- ISO 3082, 2017. Iron ores – Sampling and sample preparation procedures (ISO: Geneva).
- ISO 3084, 2002. Iron ores – Experimental methods for checking the precision of sampling, sample preparation and measurement (ISO: Geneva).
- ISO 12743, 2021. Copper, lead, zinc and nickel concentrates – Sampling procedures for determination of metal and moisture content (ISO: Geneva).
- ISO 13909-2, 2016. Hard coal and coke – Mechanical sampling – Part 2: Coal – Sampling from moving streams (ISO: Geneva).
- Pitard, F F, 1993. *Pierre Gy's Sampling Theory and Sampling Practice*, 2<sup>nd</sup> Edition (CRC Press Inc: Florida).
- Pitard, F F, 2005. Sampling correctness – A comprehensive guideline, in *Proceedings Second World Conference on Sampling and Blending*, Sunshine Coast, Australia, pp. 55-66 (The Australasian Institute of Mining and Metallurgy: Melbourne).
- Pitard, F F, 2019. *Theory of Sampling and Sampling Practice*, 3<sup>rd</sup> Edition (CRC Press Inc: Florida).



## Understanding sampling variation – a vital aspect of industrial research experiments

---

K. Engström<sup>a</sup>, R. Jolsterå<sup>b</sup> and P. Alanära Lassi<sup>c</sup>

<sup>a</sup>LKAB Kiruna. E-mail: Karin.engstrom@lkab.com

<sup>b</sup>LKAB Luleå. E-mail: Rickard.Jolstera@lkab.com

<sup>c</sup>LKAB Kiruna. E-mail: Petter.alanara.lassi@lkab.com

---

**Abstract:** Industrial research experiments are conducted in various scales in the mining industry. regardless of the experimental purpose, sampling and analysis is normally always a part of the experimental process to collect necessary data. However, in order to ensure that the experiment will enable valid conclusions, the understanding and minimisation of sampling variation is crucial. Two effective methods for evaluation of sampling variability in any process sampling situation are the duplicate and replication experiments. The application of sampling experiments in the early phases of a demo- or pilot-scale experiment is an effective way to both understand the total measurement system variability, as well as the possibility to improve sampling methods if the sampling variability is deemed too high to enable representative results to use for experimental evaluation. LKAB is an iron ore mining company in the north of Sweden where experiments are conducted in all parts of the process value chain with regularity. In the current state of the world, encountering more and more threats to our global climate and environment, a focus for LKAB has been to reduce the use of fossil fuel as well as to minimize waste and tailings. One of LKABs current environmental initiatives is to investigate the feasibility of recovering and processing apatite from tailings of the LKAB beneficiation process. Further processing of recovered apatite will generate critical raw materials, phosphorous, rare-earth elements, and fluorine. To increase the understanding of the process variability of various analytical parameters in a pilot-scale experiment within this project, both duplicate and replication sampling experiments were conducted during one of the pilot-scale campaigns. The sampling experiments were applied to three separate sampling locations where two different sampling methods were used. Results show that both sampling method and sampling experimental method can affect the results obtained. The case study showed that the sampling variability was higher for sampling locations where grab sampling was applied, in comparison to composite sampling that generated lower sampling variability at one of the sampling locations in the pilot plant. This indicate that the composite sampling method can produce more representative results and should be favourable in future process experiments. The results also indicate that the duplicate sampling experiment is more robust to outliers in comparison to the replication experiment. The duplicate experiment is also able to quantify the process variability and evaluate the relative sampling to process variability which can be an advantage in some cases.

## Introduction

Research and development are vital parts in all industrial companies in the world today. The development and existing and new industrial processes are of utmost importance in order to gain and remain in a business leading position. This is not least the case when it comes to the environmental aspects of industry today where more and more focus is turned to reduce the environmental impact from the processing industries.

Industrial research experiments are conducted in various scales in the mining industry, from laboratory scale to demo-, pilot- and full-scale. The purpose of the experiments can have endless of different purposes, but may include testing of new equipment, testing new additives or reagents as well as testing completely new process systems. Irrelative of the experimental purpose, a mandatory part of the research experiments is often to extract samples and analyse various parameters in order to understand how the process reacts to the process changes under evaluation. Both in full-scale and pilot-scale experiments, the number of sampling locations and the sampling frequency is often increased compared to everyday process sampling. The purpose of this is to maximise conclusion power from the experiment at hand. However, to ensure that the experiment will enable valid conclusions, the understanding and minimisation of sampling variation is crucial. Two effective methods for evaluation of sampling variability in any process sampling situation are the duplicate and replication experiments<sup>1, 2</sup>. This can be applied to any sampling location at any time and will generate an estimation of the sampling variability accompanied by the specific sampling method at the current process state. In order to increase the robustness of the results, the selection of experimental method and design need to be done carefully and repeated experiments may be carried out to cover a larger part of the process variability at hand<sup>3</sup>. The application of sampling experiments in the early phases of a demo- or pilot-scale experiment is an effective way to both understand the total measurement system variability, as well as the possibility to improve the sampling method if the sampling variability is deemed too high to enable representative results to use for experimental evaluation.

LKAB is an iron ore mining company located in the north of Sweden. LKAB has been in operation for over 130 years and its core business is producing highly enriched iron ore products to customers all around the world. LKAB has two underground mines in Kiruna and Malmberget and open pit mines in Svappavaara. Sorting, concentrating, and pelletizing plants are located at all three sites and the final products are shipped from harbours in Luleå and Narvik (Norway). LKAB is positioning its operation as sustainable where the mined magnetite ore only requires a third of the carbon emissions necessary for sintering of pellets compared to hematite ore, or one seventh compared to sintering of fines. LKAB is currently part of several large projects with an aim to reduce the environmental impact from industrial processes. One of these projects include Hybrit, with an aim to produce fossil free steel<sup>4</sup>.

Engineers at LKAB conduct experiments in various scales and in all parts of the process value chain with regularity. Process experiments from laboratory- to full-scale are an essential part of the continuous process and product development necessary to ensure that LKAB is able to keep delivering top quality, highly enriched iron ore products to customers worldwide. In the current state of the world, where we are encountering more and more threats to our global climate and environment, a focus for LKAB has been to reduce the use of fossil fuel as well as to minimize waste and tailings.

One of LKABs current environmental initiatives, ReeMAP, is to investigate the feasibility of recovering and processing the apatite from tailings of the LKAB beneficiation process. Further processing of recovered apatite will generate critical raw materials, phosphorous, Rare-Earth Elements (REE), fluorine and gypsum. As LKAB mines iron oxide apatite, the level of phosphorus, suggests that apatite recovery through froth flotation could be a successful method to reduce the tailings from LKAB and at the same time improve the circular economy by utilizing secondary raw material<sup>5</sup>. Mineral processing of low-grade material such as tailings can be very challenging since the feed material characteristics can limit the possibility of high recovery and acceptable grade of the final product. Low grade tailing materials, 2.8-7.2 % P<sub>2</sub>O<sub>5</sub> content from LKAB's magnetite beneficiation process have been extensively tested as feed material for apatite recovery by froth flotation in a pilot plant containing all processing steps as a full-scale plant. During initial pilot plant operation, questions regarding which level of variability and changes in experimental data was significant was raised. To be able to answer these questions, the understanding of sampling system variability in relation to process variability is crucial. As a result of these queries, several sampling experiments were included in the following pilot plant trial. To increase the understanding of the process variability of various analytical parameters in the pilot-scale experiments, both duplicate and replication sampling experiments were conducted.

## Theory of sampling

Theory of Sampling (TOS) is a complete scientific theory describing both theoretical and practical aspects of how to develop representative sampling processes of particulate material. TOS does for example give complete theoretical definitions of material heterogeneity, as well as correct increment extraction methods and empirical methods for evaluating the variability of sampling systems<sup>6, 7, 8</sup>. Sampling of particulate material is used to enable determination of various parameters for a specific lot of material. However, it is imperative that the complete sampling process is representative, in order to ensure that the analytical results that are obtained from the laboratory sample are both accurate and precise in relation to the lot material that was sampled<sup>9</sup>. With comprehensive knowledge of TOS, representative analytical results can be achieved by applying correct sampling procedures in all parts of the process. Sampling correctness is a fundamental requirement to reach effective process and quality control, as well as to reach valid conclusions from industrial experiments at all scales.

The fundamental sampling principle (FSP) signifies that all particles of the lot material should have equal probability of being collected in the sampling process. This entails that the heterogeneity of the material must be considered, and the sampling process must counteract both the constitutional and distributional heterogeneity, which can be realized by for example composite sampling and correct primary increment extraction from one dimensional material lots. All sampling processes are however coupled with sampling errors that may cause sampling bias and high sampling variability if not respectively eliminated and minimized<sup>8</sup>.

### Evaluation of sampling variability

There are several statistical and experimental methods for evaluation of the performance of industrial sampling systems and the level of associated sampling errors. In association to industrial research experiments such as pilot plant trials, it is essential to understand the variability contribution from the complete sampling and measurement system in order to decouple this variability from true process variabilities. This may also enable development of more precise sampling systems if variabilities in the initial systems are deemed too high. As pilot plant scale may be the first process trial outside of controlled laboratory studies, new sampling processes are often developed during initial setup and trials. Therefore, experimental evaluation of sampling and measurement variability can be valuable to reach an understanding of how the specific sampling method performs in the specific process location where it is applied.

Two experimental methods that can be applied to any available sampling location are the replication and duplicate experiments. The replication experiment is a fast and effective way of determining the total measurement system variability. The experiment may also be performed in various stages of the measurement system to separate sampling variability from preparation variability and analytical variability<sup>1</sup>. A single replication experiment will give a snapshot of the sampling system variability at the time of the experiment and need to be repeated several times in order to cover larger parts of the process variabilities. The replication experiment is conducted so that the primary increment extraction is repeated ten times, which results in ten separate samples. For further evaluation of the measurement variability, one of these samples can be divided in ten analytical aliquots so that the analytical procedure also is replicated ten times. In this manner, the variability of both primary sampling and measurement can be estimated.

Duplicate experiments entail that a larger process variability can be covered in one single experiment. The duplicate experiment means that every time a primary sample is extracted, this is done in duplicate to produce two separate primary samples extracted in direct repetition. By performing duplication of the primary sampling repeatedly for a specific sample location, the sampling variability can be estimated and put in relation to the process variability. Furthermore, by also duplicating the primary sample and performing duplicate analysis, the measurement variability can be estimated. The complete data set is evaluated with robust analysis of variance (RANOVA) to separate the variability contributions from sampling, analysis (measurement) and between target or process variation<sup>2</sup>. The comparison between the measurement system variability and the process variability is a powerful way of estimating the performance of a measurement system in a specific sampling location. This value is denoted total relative measurement variance in this study, and a general agreement is that this value should not exceed 20% for the sampling and measurement system to be deemed representative<sup>2</sup>.

The present case study applied both replication and duplicate experiments during a pilot plant trial with the ReeMAP project at LKAB. The application of both experiments to the same sampling locations enabled evaluation of both the sampling and measurement variability, as well as evaluation of the performance of the two experimental methods in this specific setting. The aim of the sampling experiments was to understand the magnitude of the sampling and measurement variability in order to enable valid conclusions regarding true process variability during the pilot plant trial. Furthermore, by applying both experimental methods to the same sampling locations, the results from both methods can be compared to possibly determine which method is the most applicable in future pilot plant trials within LKAB.

### ReeMAP

Metallurgical test work for the project studying apatite recovery from fresh tailings started at bench scale since it was more resource efficient, and screening tests could be carried out in a more efficient way. Results from the metallurgical bench scale test work were positive and indicated that apatite recovery from fresh tailings would be feasible<sup>10</sup>. Continuous froth flotation test work at bench scale is difficult to carry out and it is therefore beneficial to carry out continuous pilot scale test work with circulating loads. A mobile froth flotation pilot plant was designed and acquired from a mineral processing equipment supplier. Apart from technical requirements, the possibility of correct sampling of all, or at least as many as possible, of the process streams in the pilot was an important aspect during the designing phase of the pilot. This is considered as crucial since representative sampling is a key parameter to be able to draw valid conclusions from the test work results and thereby make the correct decisions regarding which of tested flowsheet designs are the most advantageous.

The pilot for the flotation test work consists of two separate 20 feet long containers, with mineral processing equipment installed. The first container in the pilot set up, container A, is for preparing of the mineral slurry for froth flotation and has screening equipment, wet low intensity magnetic separation, hydrocyclones, stirred storage tanks and one flotation cell. The second container, container B, is solely dedicated to flotation and consists of a flotation blower for providing the flotation air and seven individual flotation cells. Most of the sampling locations for the process streams are in connection with vertical tank pumps used for transporting the slurry between different unit operations in the process flowsheet, taking full advantage of TOS' 1-D lot transformation principle.

The first step in the pilot plant is removal of +355  $\mu\text{m}$  particles by wet screening. After screening, maximum particle size that needs to be considered when choosing sampling equipment is therefore 355  $\mu\text{m}$ . Slurry streams from the flotation cells are flowing by gravity into the tank of the pump and the sample was taken from that laminar flow, Figure 1.

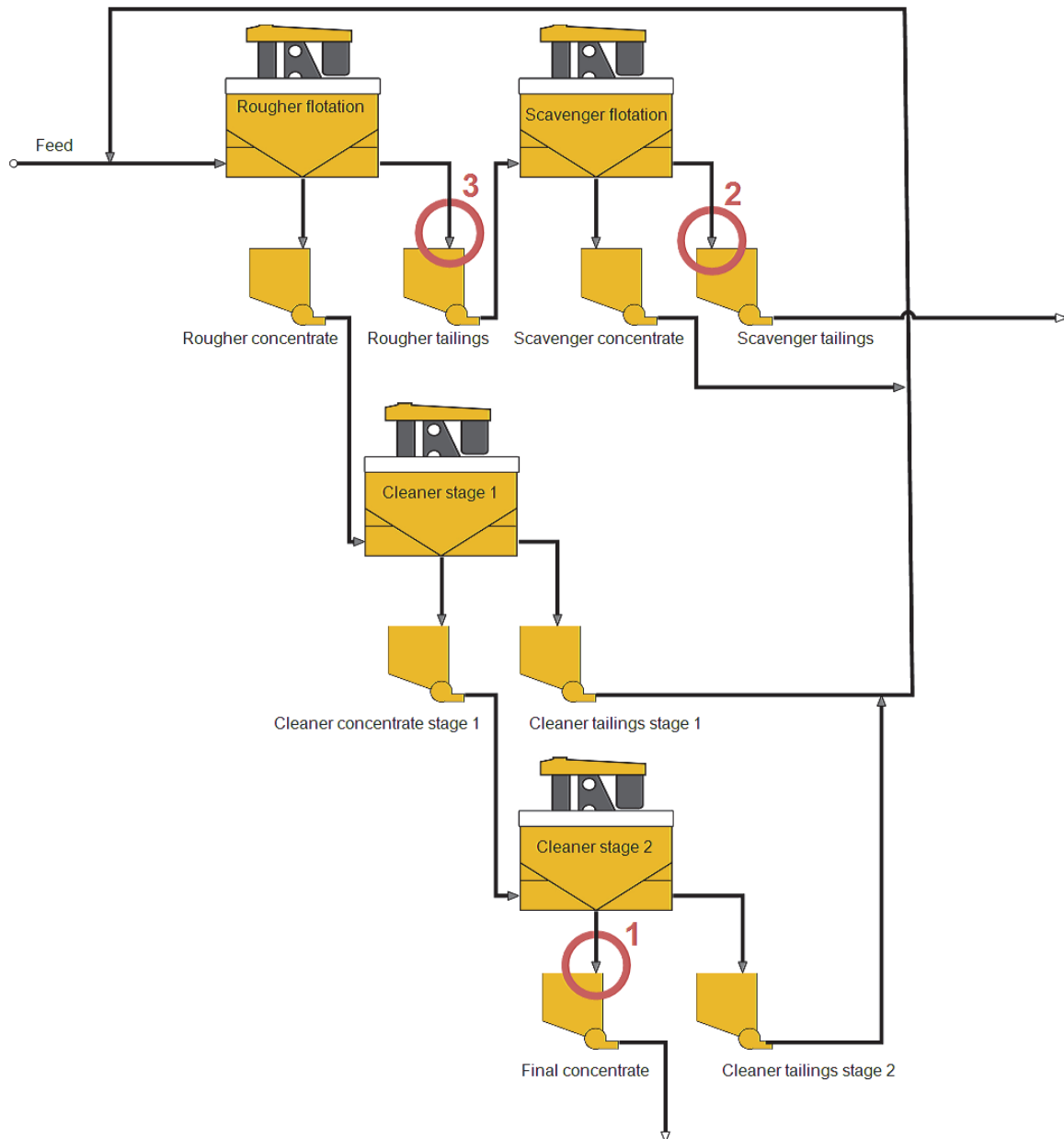

**Figure 1. Simplified process flow sheet for the flotation pilot plant. Evaluated sampling locations indicated by #1: Final Concentrate, #2: Scavenger Tailings, #3: Rougher Tailings.**

Key parameters to study and evaluate during the pilot scale test work were process stability, process behaviour for different flotation collectors and effects when feed composition of the mineral slurry varied. The sampling points evaluated in this case study were those that generate the most important process data that imply the necessity for changes in comparison to the other sampling points. These process streams are Rougher Tailings, Scavenger Tailings, Final Concentrate, Figure 1.

Analysis results from the Rougher and Scavenger tailings had shown inconsistency (see further below) in the test campaign prior to the one described in this paper. The assay for these two tailings streams holds importance about the status of the flotation process and if it is necessary to adjust the amount of added collector, since collector is added to the rougher and scavenger and if changes in collector amount or allocation between the two flotation cells should be implemented. The apatite recovery will be reduced if not enough collector is added and if too much collector is added the quality for the Final Concentrate will be lowered. Satisfactory sampling of the final product of a process is always important and this was the reason for choosing Final Concentrate as the third sampling point to investigate. Noticeable for the three process streams evaluated in this case study is the large difference in flow between the three sampling locations, where the two tailing slurry streams have a higher flow than the Final concentrate (froth product), Table 1.

**Table 1. Mean values for the weight %-solids and slurry flow for the three sampling points evaluated in the case study.**

	<b>Rougher tailings</b>	<b>Scavenger tailings</b>	<b>Final concentrate</b>
Weight %-solids (%)	26.1 – 31.6 (mean: 29.1)	28.3 – 33.4 (mean: 30.7)	19.8 – 31.7 (mean: 27.0)
Slurry flow (dm <sup>3</sup> /h)	955	855	108.3
Slurry flow (dm <sup>3</sup> /min)	15.9	14.3	1.8

### Case study - Sampling experiments at the ReeMAP plant trials

The sampling experiments in this case study were conducted during one of the first fully functional pilot plant trials conducted within the ReeMAP project. The sampling experiments were applied to three different sampling locations, Rougher Tailings, Scavenger Tailings and Final Concentrate, Figure 1, where two different primary sampling methods were used. The selection of sampling locations was based on results from the first pilot plant trial, where inconsistencies in the analytical result from Rougher and Scavenger Tailings indicated that there might be an adverse effect from sampling variability. Thus, reducing the possibilities to draw valid conclusion from the process in regard to the amount of added collector as well as related to process variabilities and output. Rougher and Scavenger Tailings are sampling locations with slurry flows of around 15 dm<sup>3</sup>/min. The larger flow for the tailings is due to the limited amount of apatite and most of the flotation process feed material will report to the tailings. The Final Concentrate is the froth product from flotation, with a flow of around 1,8 dm<sup>3</sup>/min at sampling location, Table 1. Both duplicate and replication sampling experiments were applied to all three sampling locations to enable evaluation of the two different experimental approaches as well as the sampling system variability.

Primary increments from Scavenger Tailings and Final Concentrate were extracted by allowing the entire process stream from the outlet tube fill a container, until enough material for analysis was collected, Figure 2. Rougher Tailings on the other hand was sampled by taking four increments with a manual sample cutter, Figure 2. Eight duplicate sampling rounds individual sampling rounds were conducted on each of the sampling location, where was applied in each round and a complete replication experiment was performed twice, Table 2. The sampling rounds were spread out during plant trial operation so that each experimental round was conducted during time periods with stable process parameters.

The collected material from each sampling location was dried at 105 °C for 24 hours and then divided into analytical aliquots using a riffle splitter. Roughly 100 g was prepared for the chemical laboratory and pulverized using a Herzog HP-MA pulverizing mill to less than 100 µm. From the 100 g pulverized sample, 0,72 g was extracted by taking several increments using a spatula and mixed with 8,00 g lithium tetraborate as flux, along with one drop of 20 wt % lithium bromide as non-wetting agent. A fusion borate disc was prepared using an electrical furnace. The prepared borate disk was analysed for chemical composition using a simultaneous WDXRF.



**Figure 2.** Left: Container used to collect material from the Scavenger Tailings and Final Concentrate sampling locations. Right: Manual sample cutter used for sampling Rougher Tailings, with a cutting aperture of 18 mm.

**Table 2.** Sampling schedule for the duplicate method and replication experiment. The duplicate sampling experiment was conducted on every sampling round, while the replication experiment was conducted in two of the sampling rounds.

	Duplicate sampling experiment	Replication sampling experiment
Sampling day 1	Two duplicate sampling rounds Two XRF- analyses per sample	
Sampling day 2	One duplicate sampling round Two XRF- analyses per sample	One replication experiment with 10 primary samples 10 replication XRF-analyses on one of the primary samples
Sampling day 3	Two duplicate sampling rounds Two XRF- analyses per sample	
Sampling day 4	Two duplicate sampling rounds Two XRF- analyses per sample	
Sampling day 5	One duplicate sampling round Two XRF- analyses per sample	One replication experiment with 10 primary samples 10 replication XRF-analyses on one of the primary samples



The duplicate sampling experiment was conducted with a balanced empirical design for application of RANOVA. This enables separate estimations for the sampling variability, the analytical variability as well as the process (between-target) variability for each sampling location, Figure 3. The duplicate sampling experiment was done by extracting eight duplicate primary samples in a period of 5 days during the full pilot plant trial. The duplicates were randomly distributed during the plant trial but at each time making sure that the operating conditions of the plant was stable and not affected by any noticeable adverse effects. XRF-analysis was performed on each duplicate analytical sample, 1:1A, 1:1B, 1:2A, 1:2B, etc, Figure 3.

The replication sampling experiment was conducted twice, on two random days during the plant trial. Ten primary samples were collected in rapid succession from each sampling location (1.1-1.10). Thus, the replication experiments will only provide two 'snapshots' of the total variability (sampling + subsampling + preparation + analysis) for the two time periods, Table 2. Each of the ten primary samples was analysed with XRF for chemical composition, allowing estimation of the measurement variability (sampling and analytical variability). One of the ten primary samples were further split into ten sub-samples and each of these analytical aliquots were analysed with XRF, allowing for the analytical repeatability to be estimated separately, Figure 4.

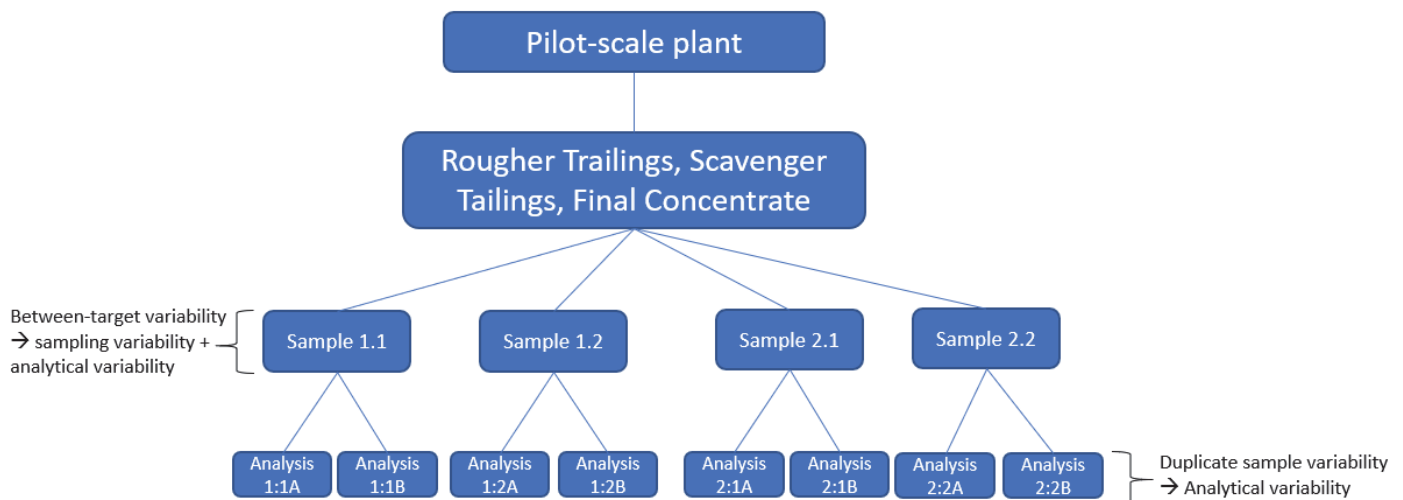

**Figure 3.** Design for the balanced empirical duplicate sampling experiment. RANOVA was used to separate the variability contributions from sampling, analysis (measurement) and between target or process variation.

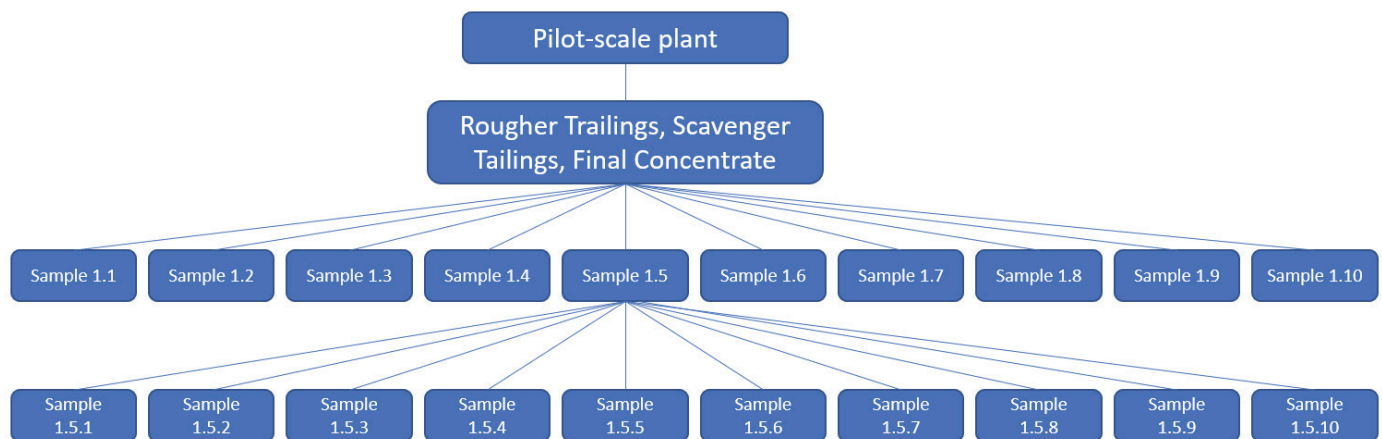

**Figure 4.** Design for the replication sampling experiment.

## Results

The results from the duplicate sampling experiments were analysed using RANOVA and the expanded relative uncertainties (U) could thereby be divided into variabilities stemming from analysis ( $U_{a\text{-duplicate}}$ ), sampling ( $U_{\text{sampling-duplicate}}$ ) and sampling + analysis ( $U_{\text{measurement-duplicate}}$ ), Table 3. The expanded uncertainties in this case study have been calculated with a coverage factor of  $K = 2$ , which corresponds to a 95% confidence interval. In order to understand the relation between measurement system variability (sampling + analysis) and process (between target) variability, the total relative measurement variance and mean value during the experiment have been calculated for each chemical parameter, Table 3. The uncertainties from the duplicate sampling experiment have been calculated for all eight duplicates together, meaning that the between target uncertainty corresponds to the process variability of the pilot plant.

The results from the replication experiment were used to calculate the expanded relative uncertainties (U) stemming from analysis ( $U_{a\text{-replication}}$ ), sampling ( $U_{\text{sampling-replication}}$ ) and sampling + analysis ( $U_{\text{measurement-replication}}$ ) which were estimated by calculating the mean value and standard deviation for the replicated samples, as well as the ten sub samples. U is expressed as the Coefficient of Variation (COV) with a coverage factor of two, Table 4. The relative total measurement variance expressed as the COV and the mean value during the experiment for each chemical parameter have also been calculated, Table 4 and 5.

**Table 3. Summary of expanded relative uncertainty from the sampling locations Rougher Tailings, Scavenger Tailings, Final Concentration during the duplicate sampling experiment. The uncertainty is estimated from RANOVA of duplicates. Coverage factor = 2, which describes a 95% confidence interval for the mean value.**

Chemical parameter	Expanded relative uncertainty from analysis			Expanded relative uncertainty from sampling			Expanded relative uncertainty from measurement (sampling + analysis)		
	Rougher Tailings	Scavenger Tailings	Final Conc.	Rougher Tailings	Scavenger Tailings	Final Conc.	Rougher Tailings	Scavenger Tailings	Final Conc.
Fe	1,3%	3,9%	4,9%	5,5%	20,9%	37,7%	5,6%	21,3%	38,0%
P	2,8%	10,0%	0,9%	6,9%	6,0%	1,4%	7,4%	11,7%	1,7%
SiO <sub>2</sub>	0,7%	1,3%	6,7%	1,1%	4,3%	17,2%	1,4%	4,5%	18,5%
Al <sub>2</sub> O <sub>3</sub>	1,1%	1,9%	14,7%	1,9%	5,3%	19,2%	2,2%	5,6%	24,2%
CaO	1,5%	1,8%	0,9%	2,6%	5,2%	0,6%	3,0%	5,5%	1,1%
MgO	0,8%	1,6%	19,4%	1,5%	4,8%	52,5%	1,8%	5,1%	56,0%
	Total relative measurement variance			Relative "Between-target" variance			Mean value		
Chemical parameter	% of total variance for measurement (sampling + analysis)			% of total variance for "Between-target"			Mean value/concentration during experiment (%)		
	Rougher Tailings	Scavenger Tailings	Final Conc.	Rougher Tailings	Scavenger Tailings	Final Conc.	Rougher Tailings	Scavenger Tailings	Final Conc.
Fe	24,0%	99,3%	24,3%	75,98%	0,7%	75,7%	9,10	11,77	0,43
P	1,5%	1,0%	5,0%	98,51%	99,0%	95,1%	0,88	0,22	16,69
SiO <sub>2</sub>	6,2%	94,4%	2,6%	93,85%	5,7%	97,4%	48,83	48,90	1,03
Al <sub>2</sub> O <sub>3</sub>	9,3%	100,0%	6,2%	90,74%	0,0%	93,8%	9,79	9,77	0,10
CaO	2,1%	19,1%	13,5%	97,95%	80,9%	86,5%	8,46	6,25	54,17
MgO	4,3%	24,4%	8,8%	95,66%	75,6%	91,2%	8,28	8,27	0,18

**Table 4. Summary of relative uncertainty from the sampling locations Rougher Tailings, Scavenger Tailings, Final Concentration during the first replication sampling experiment. The expanded uncertainty is estimated from replication experiment and expressed as the COV with a coverage factor of 2.**

Experiment 1	$U_{a\text{-replicate}}$			$U_{\text{sampling-replicate}}$			$U_{\text{measurement-replicate}}$		
Chemical parameter	Expanded relative uncertainty from analysis			Expanded relative uncertainty from sampling			Expanded relative uncertainty from measurement (sampling + analysis)		
	Rougher Tailings	Scavenger Tailings	Final Conc.	Rougher Tailings	Scavenger Tailings	Final Conc.	Rougher Tailings	Scavenger Tailings	Final Conc.
Fe	3,4%	1,6%	1,9%	2,4%	18,4%	25,0%	2,7%	18,5%	25,0%
P	5,5%	3,6%	0,6%	24,6%	7,8%	3,1%	25,1%	8,7%	3,1%
SiO <sub>2</sub>	0,5%	0,5%	2,8%	1,3%	3,7%	31,7%	1,4%	3,8%	31,8%
Al <sub>2</sub> O <sub>3</sub>	1,7%	0,6%	13,8%	0,5%	3,7%	23,2%	1,6%	3,8%	25,8%
CaO	2,0%	0,7%	0,7%	5,8%	3,6%	1,4%	6,1%	3,7%	1,5%
MgO	1,7%	0,6%	5,2%	1,1%	3,3%	48,3%	2,1%	3,3%	48,4%
Experiment 1	Relative variance			Mean value					
Chemical parameter	Variance for measurement (sampling + analysis)			Mean value/concentration during experiment (%)					
	Rougher Tailings	Scavenger Tailings	Final Conc.	Rougher Tailings	Scavenger Tailings	Final Conc.			
Fe	1,4%	9,2%	12,5%	8,90	10,25	0,61			
P	12,5%	4,3%	1,6%	0,63	0,074	15,80			
SiO <sub>2</sub>	0,7%	1,9%	15,9%	49,53	50,70	1,85			
Al <sub>2</sub> O <sub>3</sub>	0,8%	1,9%	12,9%	10,53	10,74	0,18			
CaO	3,0%	1,9%	0,8%	7,62	5,70	53,33			
MgO	1,0%	1,7%	24,2%	8,27	8,23	0,51			

**Table 5. Summary of relative uncertainty from the sampling locations Rougher Tailings, Scavenger Tailings, Final Concentration during the second replication sampling experiment. The expanded uncertainty is estimated from replication experiment and expressed as the COV with a coverage factor of 2.**

Experiment 2	$U_{a\text{-replicate}}$			$U_{\text{sampling-replicate}}$			$U_{\text{measurement-replicate}}$		
Chemical parameter	Expanded relative uncertainty from analysis			Expanded relative uncertainty from sampling			Expanded relative uncertainty from measurement (sampling + analysis)		
	Rougher Tailings	Scavenger Tailings	Final Conc.	Rougher Tailings	Scavenger Tailings	Final Conc.	Rougher Tailings	Scavenger Tailings	Final Conc.
Fe	2,2%	3,3%	2,5%	15,1%	49,1%	27,7%	15,2%	49,2%	27,8%
P	3,3%	9,5%	0,5%	25,1%	16,5%	0,9%	25,3%	19,3%	1,1%
SiO <sub>2</sub>	0,8%	0,7%	4,3%	3,4%	9,7%	9,4%	3,5%	9,7%	10,2%
Al <sub>2</sub> O <sub>3</sub>	1,4%	1,8%	36,9%	6,9%	9,9%	34,7%	7,1%	10,1%	15,5%
CaO	1,4%	3,0%	0,6%	8,0%	7,5%	0,5%	8,1%	8,1%	0,8%
MgO	1,2%	1,2%	2,5%	3,6%	9,2%	17,7%	3,8%	9,3%	17,8%
Experiment 2	Relative variance			Mean value					
Chemical parameter	Variance for measurement (sampling + analysis)			Mean value/concentration during experiment (%)					
	Rougher Tailings	Scavenger Tailings	Final Conc.	Rougher Tailings	Scavenger Tailings	Final Conc.			
Fe	7,6%	24,6%	13,9%	9,93	10,38	0,53			
P	12,7%	9,7%	0,5%	0,74	0,31	16,18			
SiO <sub>2</sub>	1,8%	4,8%	5,1%	48,47	49,85	1,89			
Al <sub>2</sub> O <sub>3</sub>	3,5%	5,0%	7,7%	9,86	10,06	0,15			
CaO	4,0%	4,1%	0,4%	7,66	6,40	53,42			
MgO	1,9%	4,6%	8,9%	8,44	8,55	0,49			

## Discussion

The results from this case study clearly show that the sampling system largely affects the level of total measurement system variability. Especially when comparing the sampling variability between Rougher Tailings and Scavenger Tailings, where different primary sampling methods were applied, while the mean concentration of most parameters are similar. The estimated sampling variabilities for Rougher Tailings and Scavenger Tailings are significantly different for several parameters, where Rougher Tailings have a smaller sampling variability compared to Scavenger Tailings. This strongly indicates that the primary sampling method used for Rougher Tailings, where four increments were collected with a manual sample cutter, results in lower sampling variability than collecting the complete process stream in one larger container. Collecting a sample with this single round container means that the primary sample extraction violates several of the main principles of the TOS and leads to increment delimitation and extraction error among many others. This also imply that only one increment is collected for each sample, and this is extracted in an incorrect manner, i.e. a grab sample that can never be representative. The case study results thereby imply that composite sampling, where several increments are collected and combined to a primary sample, results in lower variability than collecting a single large grab sample. This conclusion is supported by the Theory of Sampling, where composite sampling is strongly recommended in order to achieve representative samples.

The relative sampling uncertainty for Final Concentrate is higher compared to Rougher Tailings, but the mean value for the chemical parameters for Final Concentrate also differs compared to Rougher Tailings and Scavenger Tailings. This complicates the comparison as relative uncertainties always correlates to the concentration level of the chemical parameter at hand. In addition to the differences in mean values, the physical character of the material also differs, where the Final Concentrate is a froth product from the froth flotation process, while Rougher Tailings and Scavenger Tailings are liquid slurry tailings from the same process.

The duplicate sampling experiment was conducted eight times during a five-day period, allowing for estimation of the process variation. An important advantage from the duplicate sampling experiment, is that the different variabilities are estimated over a larger concentration interval, due to the inclusion of the process variability over a longer time-period compared to the replication experiment. The duplicate experiment also gives the possibility to compare the variability in the measurement system to the total process variability, which gives an indication of the ability of the measurement system to describe the true process fluctuations. This 'total relative measurement variance' is calculated as the variance for sampling + analysis divided by the between target variance (process variability) and is a valuable indication of how well the measurement system is able to describe the process variability. The total relative measurement variance for Rougher Tailings and Final Concentrate are both below 20 % for most of the chemical parameters, while close to 100 % for most of the chemical parameters for Scavenger tailings. This implies a difficulty to evaluate process data from Scavenger tailings as it is impossible to know if the variability in the data comes from actual process changes or solely from the measurement system. Sampling and measurement system variabilities of this magnitude makes it impossible to draw valid conclusions from an industrial experiment such as this pilot-plant campaign<sup>11</sup>.

The relative analytical uncertainty estimated from both the duplicate experiment and the replicate experiment is larger for the Final Concentrate, compared to the two sampled tailings, for most of the chemical parameters. Noticeable is that the Final concentrate is a froth product that may be more affected by the inter-laboratory sample preparation variability (which in this study is included in the analytical variability). This could indicate that the in-laboratory sample preparation and analytical method is more suitable for the two tailings products containing higher concentrations of iron and silica, in comparison to the froth product of Final concentrate with high concentration of phosphorus and calcium. This is likely do to the fact that the in-house laboratories used in this case study are more adapted for the routine iron ore samples from the concentrating and pelletising plants of LKAB.

The results from both the duplicate- and replication sampling experiments showed that the two experimental methods estimate similar analytical and sampling variabilities in the current case study. However, the variabilities observed in the two separate replication experiments showed diverse results for some chemical parameters. This is due to the fact that one of the ten primary samples in the second replication experiment is a significant outlier compared to the rest of the data, and therefore greatly affect the estimated sampling variability.

The replication experiment was only conducted twice in this case study and is therefore more sensitive to outliers. An example of this is replication sample 2.6 from Scavenger Tailings, table 6. To ensure that this was not an analytical error, new analyses was conducted on the archived material from both the laboratory as well as from the sampling experiment. Both additional analyses showed the same outlying result. One reason for this could be beneficiation of hematite in the tailing product of the froth flotation process, which can suddenly release into the sample stream and result in such an outlying value. As the root cause for this outlier has not been possible to determine, the authors deem that repeating the calculation after removal of the outlier would most likely underestimate the sampling variability and is therefore not a feasible alternative. This one outlier is the reason for the estimated sampling variability to be higher for the second replication experiment compared to the first one. This shows the strength of duplicate sampling experiments in combination with RANOVA as a suitable method to handle scenarios with possible outliers. This also indicate that it is of great value to perform replications experiments regularly to monitor the sampling variability over time and reduce the effect of isolated outliers to the overall estimation of sampling variability.

The results from the replication experiments shows that this method is sensitive for single outliers. To ensure the validity of replication sampling experiments, it is therefore important to reproduce the experiment several times in order to understand the sampling process fully, as well as to enable identification of single outliers and how they may affect the sampling process. Furthermore, in a process where these kinds of large and sudden process variations do occur, the sampling process must be designed to handle the process variations so that necessary changes are detected, while sudden incidents that do not affect the overall process performance does not corrupt the data analysis, and therefore affect the conclusion power for the process experiments. However, the replication experiment is a rewarding method to reach quick conclusion regarding the variability of the applied primary sampling methods. The replication experiment in this case study indicates that composite sampling with several increments is less likely to result in outliers and thereby more robust for valid conclusions regarding process changes.

**Table 6. XRF-analysis data on each of the ten primary replication samples, from the two separated experiments conducted on the Scavenger Tailings. Primary sample 2.6 show deviating XRF-results compared to all the other samples in both replication experiments. This outlier strongly affects the sampling variability estimation for the replication experiment.**

Scavenger Tailing	Replication sample	Fe (%)	P (%)	SiO <sub>2</sub> (%)	Al <sub>2</sub> O <sub>3</sub> (%)	CaO (%)	MgO (%)
Experiment 1	1.1	9,998	0,073	50,580	10,788	5,671	8,283
	1.2	9,460	0,069	51,209	10,879	5,702	8,302
	1.3	10,284	0,075	50,672	10,781	5,699	8,260
	1.4	9,960	0,076	51,022	10,847	5,744	8,328
	1.5	10,075	0,076	50,715	10,756	5,722	8,265
	1.6	12,668	0,075	48,256	10,252	5,423	7,904
	1.7	9,246	0,076	51,771	10,982	5,728	8,353
	1.8	9,972	0,079	51,288	10,779	5,834	8,273
	1.9	10,770	0,071	50,316	10,554	5,743	8,074
	1.10	10,022	0,070	51,189	10,809	5,695	8,210
Experiment 2	2.1	11,137	0,296	49,214	9,929	6,299	8,410
	2.2	10,858	0,385	49,063	9,897	6,587	8,483
	2.3	9,360	0,311	50,779	10,251	6,461	8,660
	2.4	10,344	0,270	50,030	10,293	6,163	8,657
	2.5	9,366	0,329	50,851	10,162	6,582	8,731
	2.6	17,183	0,295	43,433	8,719	5,772	7,490
	2.7	8,645	0,306	51,324	10,421	6,472	8,797
	2.8	8,923	0,301	51,502	10,412	6,481	8,802
	2.9	9,518	0,321	50,812	10,161	6,584	8,690
	2.10	8,480	0,321	51,485	10,390	6,569	8,797

## Conclusions

This case study shows that the estimated sampling variability is largely affected by the applied primary sampling method together with the design of the sampling experiment. The total relative measurement variance from the duplicate experiment was under 20 % for most of the chemical parameters for Rougher Tailings and Final Concentrate. This is considered acceptable since no predetermined requirement was set for any of the sampling locations. The total relative measurement variance for Scavenger Tailings was over 20 % for most of the analysed chemical parameters, and the sampling variability was contributing to the largest part of the measurement system variance. This is a clear indication that the primary sampling method has a large influence on the total measurement system variability within this case study. It also highlights the importance of adapting and evaluating the sampling methods individually for each sampling location and in all industrial experiment setups.

The duplicate experiment in combination with a RANOVA, was shown to be a more comprehensive method to estimate the measurement variabilities in industrial experiments, compared to the replication experiment. An important benefit with the duplicate sampling experiment is the generation of less samples to handle for sampling- and laboratory staff, especially considering a full-scale sampling experiment replicating both sampling, sometimes sample preparation, and analysis. Duplicate sampling experiments also have the advantage of covering a wider timeframe and enable evaluation of the total process variability. This allows for comparison between measurement system and process variability which clearly indicate the possibilities to draw valid conclusions from the measurement data produced.

The sampling variability in the evaluated pilot plant trial was lower for the composite sampling process using a manual sample cutter to collect several increments for each primary sample for Rougher Tailings. The sampling process using a sample container to collect one grab sample from the process stream, applied on Scavenger Tailings, resulted in larger sampling variability. The composite sampling process should therefore be advocated for use on all sampling locations in future pilot plant trials. Comparison between the sampling variability for Final Concentrate to the two tailings products is challenging as the mean value for all parameters differ a lot, together with this being a froth product compared to the tailings being slurries. These two facts also resulted in discrepancies in analytical uncertainty between these two material types.

The results from this case study show that sampling experiments are valuable in order to estimate the variability stemming from both sampling and analysis for different sample locations and various materials being sampled. By applying sampling experiments in initial pilot plant trials, as well as other industrial experiments at various scales, the complete measurement process can be evaluated, and primary sampling methods can be improved to reach lower sampling variability in future plant trials. The application of sampling experiments in this case study could clearly show that the composite sampling method resulted in significantly lower sampling variability than the grab sampling method. This is an important knowledge in further pilot plant trials where the composite sampling method can be applied to all sampling locations in order to reduce the measurement system variability. The replication experiment is concluded to be an efficient method to receive a snapshot of the performance of the complete sampling and measurement system in any industrial process sampling situation. An important advantage with the replication experiment is that it is a fast and effective way to give an indication of the level of sampling variability connected with the primary sample extraction method. However, in order to also understand the correlation between the total measurement system variability and the process variability, the duplicate sampling experiment is a rewarding method. This understanding may for example be important in order to evaluate if a small change in process data actually is of importance or if it may be explained by sampling and measurement variability.

## References

1. K.H. Esbensen, C. Wagner, Sampling quality assessment: the replication experiment. *Spectroscopy Europe* 28(1):20-25 (2016).
2. M.H. Ramsey, M. Thompson, and M. Hale, Objective evaluation of precision requirements for geochemical analysis using robust analysis of variance. *Journal of Geochemical Exploration* 44:23-36, (1992). [https://doi.org/10.1016/0375-6742\(92\)90046-B](https://doi.org/10.1016/0375-6742(92)90046-B)
3. K. Engström, L. Olausson and K.H. Esbensen, Experimental Evaluation of Surface Water Sampling Variability for Environmental Monitoring in Iron Ore Operations. *International Journal of Mine Water* 38(1), (2019). DOI: 10.1007/s10230-019-00598-1.
4. HYBRIT Development AB, Sweden, accessed 1 march 2022, <<https://www.hybritdevelopment.se/>>
5. LKAB Minerals AB, Sweden, accessed 1 march 2022, <https://ree-map.com>
6. K.H. Esbensen and P. Paasch-Mortensen, Process Sampling: theory of sampling—the missing link in process analytical technologies (PAT). In: *Bakeev KA (ed) Process analytical technology, 2nd edn*. Wiley, Chichester, pp 37–80 (2010)
7. R. Minnitt and K.H. Esbensen 2017, Pierre Gy's development of the Theory of Sampling: a retrospective summary with a didactic tutorial on quantitative sampling of one-dimensional lots. *TOS Forum* 7, p. 7-19, (2017). DOI: 10.1255/tosf.96
8. F.F. Pitard, *Pierre Gy's sampling theory and sampling practice: heterogeneity, sampling correctness, and statistical process control*. CRC Press LLC, Boca Raton (1993). ISBN: 0-8493-8917-8.
9. R.J. Holmes Sampling mineral commodities – the good, the bad, and the ugly. *Journal of the Southern African Institute of Mining and Metallurgy* 110, 269–276, (2010).
10. R. Jolsterå, E. Niva, E. Widetun, K. Taavoniku and V. Töyrä, Recovery of apatite from mine tailings by froth flotation. *Conference proceedings Flotation '19*, Cape Town, (2019).
11. S. Brochot, Sampling for Grinding Pilot Plant Test – The Effect of Size Distribution Variability. *Sampling conference*, Perth, (2012).



# A comparison between conventional blast hole sampling and diamond core drilling for copper grade at the Antapaccay mine

F. Toconas<sup>a</sup>, L.S. Jordan<sup>b</sup> and S. Kedda<sup>c</sup>

<sup>a</sup>South America Quality Control-Glencore. E-mail: felix.toconas@glencore.com.pe

<sup>b</sup>Quality control Superintendent of Antapaccay. E-mail: lytman.jordan@glencore.com.pe

<sup>c</sup>Manager Quality Assurance-Glencore. E-mail: sean.kedda@glencore.com.au

**Even though the sampling technique result in potentially biased samples with poor precision of the metal grade and are classified as specimens and not samples, the manual sampling of rotary percussion blast hole chips is still widely performed in the industry for operational grade control purposes.**

**The objectives of this investigation are to estimate the precision and "bias" of manual sampling by comparing the copper grade results of fifteen (15) diamond drill core samples versus fifteen (15) rotary percussion blast hole drilling chip samples. This also includes the determination of a practical manual sampling template with the highest precision to provide an understanding of the distribution of the copper content within the cone of blast hole chips. The contouring plots of the copper grades provides the selection of the best fit-for-purpose template with regards precision and operational resourcing requirements. The diamond drill core samples take into account the Increment Delimitation Error (IDE) and Increment Extraction Error (IEE) and therefore can be considered as reference samples for the purpose of this review.**

## INTRODUCTION

Production and service processes need to be periodically evaluated by suitable indicators, not only for its control, but for its improvement over time. But what affects these processes? Deming quoted *"if I had to reduce my message to managers to just a few words, I would say it all had to do with reducing variation"*<sup>1</sup>. Thus, variation must be measured, controlled and reduced through improvements in technology, process design and training of people.

Sampling is a critical issue throughout the mine value chain, where it includes the sampling of both *in situ* and broken material. In all cases, the aim is to obtain a representative sample to accurately describe the material in question<sup>2</sup>.

A sample might be described as being representative when it results in acceptable levels of both bias and precision<sup>3</sup>. Sampling precision can be estimated, but bias is difficult to estimate without generally impractical and costly experimental efforts. Contrary to analytical biases, sampling biases are extremely difficult to detect because of material segregation. A valid Quality Control program is required to address Incremental Delimitation Error (IDE), Increment Extraction Error (IEE), Increment Preparation Error (IPE) and Increment Weighing Error (IWE)<sup>4</sup>.

The open pit mining industry for various operational and costs constraints has commonly adopted sampling of conventional rotary percussion air blast (RAB) drilling chips that are collected around the drill hole as a source of samples. The data is used to generate short-term models for mine planning and ore control even though this technique does potentially compromise the representativity of the samples collected and submitted for analysis.



This flawed data potentially compromises pit grade control operations and potential errors in waste versus economic ore designation and extraction.

The present investigation is an evaluation of the precision of samples collected from rotary percussion drilling chips generated and exhausted from the hole and accumulated around the drill. A template of forty (40) independent increments called the "reference template" were collected from the cone of the exhausted material are then compared with twelve (12) different possible sampling patterns/templates. Distribution of drilling chips in the cone does not follow a systematic pattern and is influenced by various factors including geology, drill rig orientation, water table interaction and overall recovery of the drilling chips. The bias of this sampling method was evaluated by comparison of the blast hole sampling data with twinned conventional diamond drill hole core samples which considers the Increment Delimitation Error (IDE) and Increment Extraction Error (IEE) sampling errors.

## **GEOLOGY OF THE ANTAPACCAY COPPER-GOLD-SILVER DEPOSIT**

The Antapaccay mine is 9.4 kilometers southwest from the Tintaya mine site and is a copper-gold-silver porphyry-skarn type ore deposit hosted within the Andahuaylas-Yauri Cupriferous Belt of the Peruvian Andes<sup>5</sup>. It forms part of the Tintaya district which is a Cretaceous limestone/calcareous and siltstone dominated sedimentary series with various intrusive monzonitic plutons. The Antapaccay mine copper mineralization averages 0.52% copper and is hosted predominantly within the monzonite-diorite intrusive associated with finely disseminated chalcopyrite, bornite and chalcocite with only minor quantities of sulphide veinlets. There are some quartz veinlets and stockwork zones commonly associated with higher copper/gold grade and coarser sulphides species as well as irregular contact skarns and mineralized stockworks hosted within the sedimentary units.

The importance of the size distribution, density and the liberation characteristics of the copper species are critical not only for Fundamental Error (FSE), but also for the impact of the economic controls as a result of mineral segregation and/or preconcentration during the sampling of the blast hole drilling chips. The copper sulphide species being potentially rejected or concentrated while the blast holes are drilled due to density/size segregation as well as hole erosion thus potentially resulting in biased samples being collected for the grade control operations

## **ROTARY BLAST HOLE DRILLING AND MANUAL SAMPLING OPERATIONS.**

For this present review, fifteen (15) blast holes were drilled using two (2) tracked mobile rotary percussion air blast drill machines (RAB) using a 12 ¼ inch diameter tricone bit operating at an air pressure of 60 pounds per square inch (PSI). Typically, the generated drilling chips collected around the drill hole are 95% less than 10 millimetres and P50 of 2 millimetres.

The drill hole spacing and drilling procedures were as per the mine's present standard blast hole pattern and internal quality control measures. This investigation was to simulate typical operational variability in blast hole drilling conditions with regards copper grades, mineralization variability and style as well as ground water content and its interaction with the drill units. The present rotary percussion blast hole sampling of the mining bench is divided into two steps:

- Rotary percussion drilling of the designated bench to a depth of fifteen (15) meters. This generates approximately three (3) metric tons of drill chips per hole that are distributed in a cone shape around the blast hole and drill string.
- Manual subsampling of the drill chips from each individual blast hole that are sent to the onsite laboratory for geological mapping and chemical analysis that is used for operational grade control management.

The percussion drilling and subsequent sampling of the generated drill chips is considered to generate various systematic sampling errors including bench delimitation with an over drilling/erosion, sample recovery errors

associated with loss of material into fractures as well as material losses during the extraction of the drill chips by ground water interaction and air blown dust/fines losses.

The loss of material is inherent in the rotary percussion drilling processes and sample collection procedures and any operational improvements are limited to the improved sampling of the material exhausted and deposited around the blast hole. It is probable that the material sampled does not represent the material from the blast hole profile thus providing operational challenges in using this data for ongoing grade control operations and waste/ore designation.

The large mass of the percussion drill chips, variable cone shape as well as the extremely heterogeneous distribution of the copper content within the cone of material due to segregation are all challenging issues. The task is to design an effective subsampling protocol to provide unbiased data for operational grade control and metal reconciliation with the existing block model. In addition, due to operational and blasting production constraints there is limited time for extensive manual sampling or field division processes to take larger and/ or additional samples.

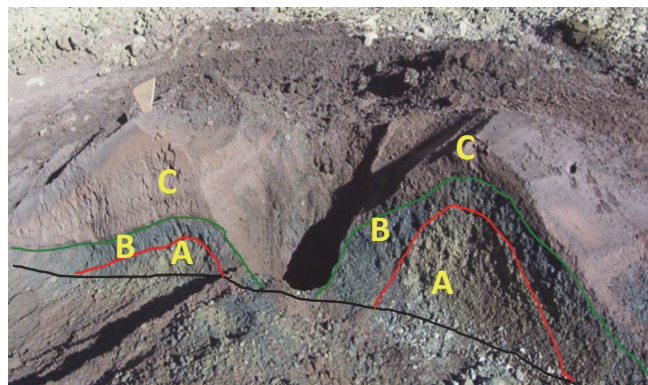

**Figure 1.** Cross-section example of a typical blast hole drill chip cone. The distribution of drill chips is highly heterogeneous both horizontally and vertically relative to the blast hole.

#### **FORTY (40) INCREMENT REFERENCE TEMPLATE FOR EVALUATING PERCUSSION DRILLING SAMPLING PRECISION**

The investigation included a forty (40) increment sampling template distributed radially over the percussion drilling chips cone to consider the heterogeneity of metal content, variable shape of the cone and effect of water content. The objective of the template is to collect multiple increments to provide better understanding of the distribution, range and average metal values allocated for the blast hole and is identified as the “Reference Template” (Figure 2 and 3). For this initial review, only the total copper content reported in percentage (%) is considered.

Each increment is collected manually using an 80-millimetre diameter, electric powered, hand-held auger unit inserted perpendicular to the slope of the cone (Figure 4) to generate a sample of approximately three (3) kilograms each. The individual samples are dried, crushed to less than three (3) millimetre and divided using a rotary sample divider to obtain approximately 500 grams of sample. The samples are pulverised/reduced using an Essa® LM2 single disk type mill to a nominal top size of 106 micron.

The reduced samples are homogenised, divided and assayed individually using the mine’s site laboratory routine internal procedures consisting of a four-acid digestion and Atomic Absorption Spectroscopy (AAS) measurement with standard quality control procedures, including appropriate internal and external reference materials.

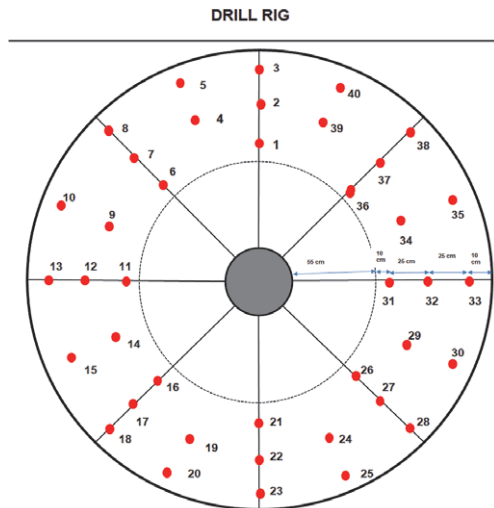

**Figure 2.** Forty (40) increment sampling "Reference Template "BH100" (red dot sampling points). First increment is collected perpendicular to the drilling rig.



**Figure 3.** Reference Template sampling points over the blast hole cone

The analysis of the individual forty (40) increments provides the characterisation of the copper grade distribution within the percussion drilling chip cone. Based on this information it is possible to design the alternative sampling templates and calculate their precision comparing to this Reference Template, such as those provided in Appendix 1.



**Figure 4.** 80-millimeter diameter electric powered, hand-held auger collecting samples perpendicular to the slope of the cone



**Figure 5.** Fabricated sectional metal frame used for the investigation to collect a complete profile through the cone of drilling chips

In addition to manual sampling with the hand-held auger device, sampling with a sectional metal frame was considered as another possible sub-sampling technique (Figure 5). After forty (40) increments samples are collected, a channel is dug next to the sampling profile and a fabricated sectional steel sampling frame is inserted from the top to bottom of the exposed section of the cone see Figure 5.

The sectional metal frame considers the radial shape to the center of the hole and at eight (8) degree of aperture. This has a minimum aperture of four (4) centimeters near the blast hole and is 120 centimeters in length. However, due to the large mass of each sample (>30 kilograms) the use of the metal sectorial frame is only considered as an evaluation procedure and is not a practical procedure for routine sampling and evaluation.

## ANALYSIS OF RESULTS

The copper content in the forty (40) samples collected individually from the blast hole cone were used to contour the obtained copper grade distribution (Figure 6 and 7) over the cone profile. The contour plot in example BH01 the copper content was observed to be enriched in the area opposite to position of the drill rig and contains up to 0.70% copper with a range between 0.20% copper and a maximum of 0.76% (average for hole is 0.35% copper).

The focused concentration of the copper content is striking, suggesting that the deposition of drilling chips is by sections and/or an enrichment due to the effect of density segregation of the particles by the drill flushing air.

Another example (BH06) demonstrated a spiral shaped copper distribution located in the southeast quadrant of the cone with a content of 0.70% copper and reaching the outer southwest quadrant with an enriched content of 2.52% copper. The copper grades demonstrated a large variability between 0.48% to 2.52% copper between the forty increments. (Average for this blast hole is 0.89% copper).

The distribution indicates high variability and with the copper content commonly concentrated /enriched in specific zones of the percussion drilling chip cone.

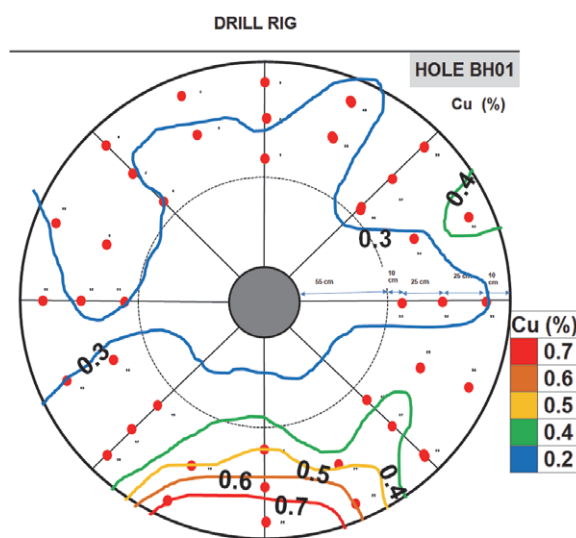

**Figure 6.** Copper content of blast hole BH01 showing copper enrichment in one specific area of the southern part of the cone closest to the drilling machine

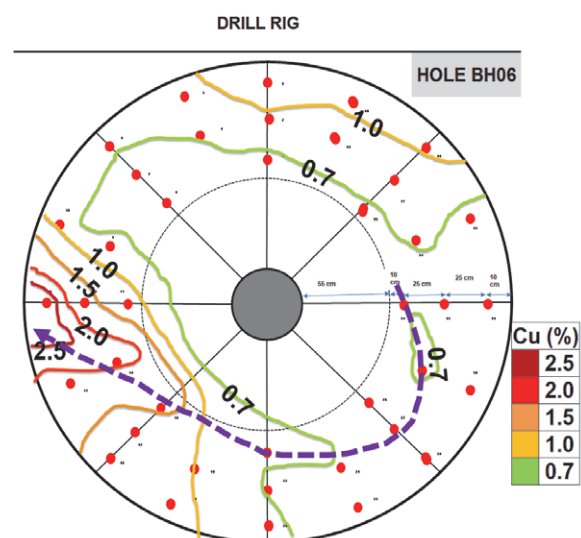

**Figure 7.** Copper contour of blast hole BH06 showing spiral distribution of copper enrichment

The observed accumulation/ enrichment of copper content in certain sectors of the drill chip cone is attributed to:

- Non-uniform horizontal deposition of chips during the drilling possibly as a function of airflow out of the hole and interaction with the drill machine orientation and possibly prevailing wind direction.
- Effects of air flow channeling by the canvas panels around the drill string installed by drill operators to reduce dust losses/generation resulting in an unequal air flow around the hole orifice.
- Variability in geological units with variable copper mineral content in the blast hole profile due to erosion/over sampling of lithologies.
- Variable operator techniques and time pressure to complete the operations resulting in variable drilling rates.
- Loss of lower density/fine gangue minerals by interaction with air/water flows including air losses into fractures.

The irregular heterogeneity and segregation of drilling chips within and around the cone is demonstrated in the vertical and horizontal plane of the cone producing challenges to collect representative samples of the blast hole profile. Applying the sampling methodology of multiple independent increments in the cone of drilling chips is critical and fundamental to find the appropriate sampling tool or template for routine operations. This will ensure that the percussion drilling blast hole sampling can be used for operational grade control and geological reconciliation.



**Figure 8.** Material around the rotary percussion drilling cone of blast hole (BH01). Note the material size segregation

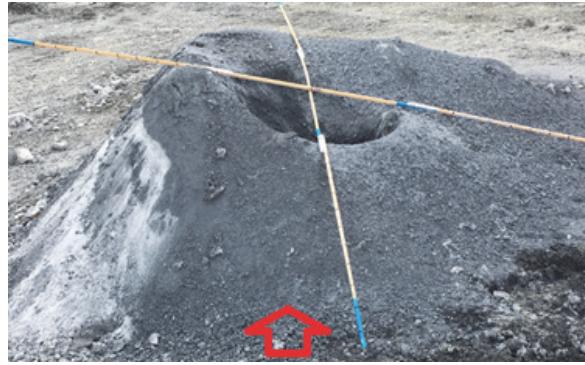

**Figure 9.** Material around rotary percussion drilling cone of blast hole (BH06) (looking towards drill rig). Note the irregular shape of drill chip cone.

In addition, this type of review provides information on the other variables of interest including granulometry of the generated chips, weight of samples and shape of the cone (Figure 8 and 9). These variables can be plotted on a contour map to visualize the distribution of the elements or variable of interest in the material cone. Since these samples are independents and it is then possible to compare the “Reference Template” versus other proposed operational sampling templates. Considering that this reference data provides the ability to define fit-for purpose sampling plan for routine operations.

### **SIMULATION RESULTS OF REFERENCE TEMPLATE VERSUS OTHER POSSIBLE SAMPLING TEMPLATES.**

Using the forty (40) increment template (Reference Template) copper grades it is possible to calculate the copper grade of twelve (12) other possible sampling templates (T1 to T12 - Appendix 1). These possible templates range from 8 to 24 increments and weigh between 6 to 50 kilograms.

In order to select the most appropriate sampling template for both operational and precision requirements, the copper average grade of the Reference Template is compared with each of the twelve (12) possible template's calculated average copper grade (Table 1). Selecting the template that has less than <5% of precision or dispersion versus the Reference Template (Table 2 and Figure 10).

**Table 1** - Summary of each possible sampling template (T1-T12) calculated total copper grade and Reference Template (RT) for each blast hole.

Template	ID	Cu (%)												RT*
		T1	T2	T3	T4	T5	T6	T7	T8	T9	T10	T11	T12	
		No increments	8	8	8	8	12	12	12	12	16	16	24	
Blast Hole No.	BH01	0.383	0.312	0.367	0.368	0.419	0.307	0.348	0.353	0.346	0.367	0.356	0.351	0.349
	BH02	0.406	0.433	0.418	0.440	0.416	0.432	0.431	0.417	0.418	0.430	0.424	0.424	0.423
	BH03	0.445	0.436	0.462	0.503	0.489	0.474	0.564	0.448	0.441	0.482	0.482	0.502	0.476
	BH04	0.800	0.688	0.846	0.719	0.812	0.680	0.702	0.834	0.753	0.778	0.756	0.763	0.750
	BH05	0.769	0.838	0.721	0.843	0.790	0.836	0.864	0.730	0.805	0.780	0.814	0.798	0.815
	BH06	0.885	0.930	0.614	1.175	0.806	0.977	1.151	0.647	0.906	0.909	0.891	0.911	0.887
	BH07	0.316	0.306	0.338	0.338	0.344	0.322	0.333	0.313	0.345	0.322	0.336	0.323	0.337
	BH08	0.435	0.434	0.447	0.477	0.444	0.440	0.452	0.439	0.435	0.463	0.442	0.446	0.450
	BH09	1.171	1.064	1.113	1.096	1.170	1.081	1.124	1.097	1.123	1.105	1.129	1.111	1.119
	BH10	0.478	0.518	0.532	0.518	0.496	0.530	0.519	0.533	0.499	0.525	0.515	0.525	0.509
	BH11	0.178	0.230	0.183	0.247	0.187	0.226	0.238	0.187	0.202	0.212	0.206	0.210	0.212
	BH12	0.425	0.385	0.371	0.389	0.420	0.399	0.400	0.400	0.407	0.380	0.411	0.400	0.394
	BH13	0.337	0.310	0.306	0.296	0.341	0.303	0.300	0.314	0.323	0.301	0.322	0.306	0.313
	BH14	1.082	1.169	1.042	1.090	1.116	1.165	1.108	1.108	1.122	1.068	1.141	1.108	1.121
	BH15	0.830	0.926	0.814	0.945	0.825	0.925	0.977	0.801	0.879	0.882	0.880	0.894	0.879

RT\*= Reference template

**Table 2.** Calculated Relative Difference of the possible sampling templates versus the Reference Template for each blast hole.

Template	ID	Relative Difference Percentage of sampling template versus reference template (%)											
		T1	T2	T3	T4	T5	T6	T7	T8	T9	T10	T11	T12
		No increments	8	8	8	8	12	12	12	12	16	16	24
Blast Hole No.	BH01	9.2	-11.2	5.0	5.2	18.1	-12.8	-0.3	1.0	-0.9	5.1	2.0	0.4
	BH02	-4.1	2.4	-1.0	4.1	-1.5	2.3	1.9	-1.4	-1.1	1.7	0.3	0.3
	BH03	-6.8	-8.7	-3.0	5.6	2.7	-0.4	17.0	-6.1	-7.6	1.3	1.2	5.2
	BH04	6.4	-8.6	12.0	-4.3	7.9	-9.9	-6.7	10.6	0.3	3.6	0.8	1.6
	BH05	-5.7	2.8	-12.2	3.4	-3.1	2.6	5.9	-10.9	-1.2	-4.3	-0.1	-2.1
	BH06	-0.1	4.8	-36.4	28.0	-9.6	9.7	26.0	-31.2	2.2	2.5	0.4	2.7
	BH07	-6.6	-9.7	0.3	0.3	2.0	-4.5	-1.4	-7.5	2.4	-4.6	-0.5	-4.3
	BH08	-3.3	-3.5	-0.6	5.9	-1.3	-2.2	0.6	-2.4	-3.4	2.9	-1.7	-0.9
	BH09	4.5	-5.0	-0.5	-2.1	4.5	-3.4	0.4	-2.0	0.3	-1.3	0.9	-0.8
	BH10	-6.4	1.7	4.5	1.8	-2.6	4.0	1.8	4.5	-1.9	3.1	1.1	3.1
	BH11	-17.3	8.1	-14.6	15.0	-12.5	6.1	11.7	-12.8	-4.9	-0.1	-2.9	-0.8
	BH12	7.4	-2.4	-6.2	-1.4	6.4	1.1	1.5	1.5	3.1	-3.6	4.1	1.5
	BH13	7.3	-1.1	-2.3	-5.6	8.3	-3.4	-4.4	0.2	3.1	-4.1	2.8	-2.4
	BH14	-3.5	4.2	-7.2	-2.8	-0.5	3.9	-1.2	-1.1	0.2	-4.8	1.8	-1.1
	BH15	-5.8	5.2	-7.7	7.2	-6.3	5.1	10.6	-9.3	0.1	0.3	0.1	1.7

Dispersion as a relative difference of the twelve (12) individual sampling templates versus the reference template copper values to measure the degree of precision for each calculated sampling template.

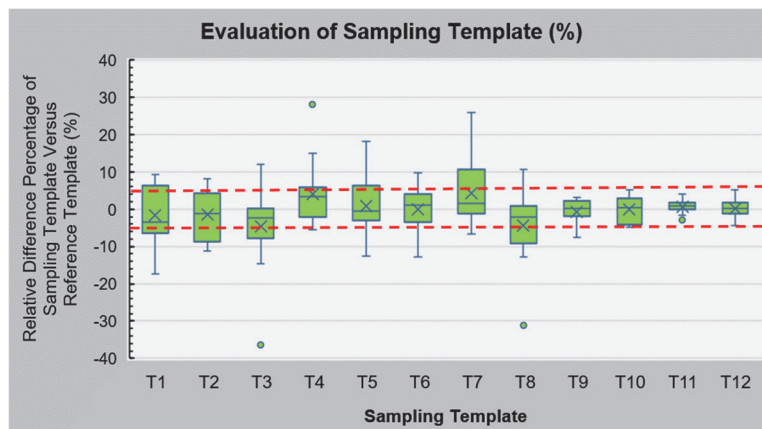

**Figure 10.** Precision chart of each individual sampling template versus the Reference Template.

Comparisons of the calculated twelve (12) sampling templates versus the Reference Template indicate that the templates T9 and T10 (Appendix 1) have lowest calculated precision < 5% (Figure 10). These results are supported by the total sample weight in a practical range of 15 to 30 kilograms that can be reduced to a subsample of 6 to 10 kilograms for additional sample preparation and analysis (Table 3). Both of these sampling templates (T9 and T10) were also tested for reproducibility and can be considered original and field duplicates.

**Table 3.** Summary of calculated sample weight (kilograms) of each possible sampling template (T1-T-12) for each blast hole

Template	ID	Sample weight of each sampling template (kg)											
		T1	T2	T3	T4	T5	T6	T7	T8	T9	T10	T11	T12
	No increments	8	8	8	8	12	12	12	12	16	16	24	24
Blast Hole No.	BH01	9	9	11	7	12	16	13	17	18	18	28	29
	BH02	13	10	11	12	18	17	19	18	23	22	36	36
	BH03	7	5	5	5	10	9	9	10	12	10	19	19
	BH04	12	9	10	11	19	14	18	15	20	21	33	33
	BH05	9	10	11	10	15	16	17	16	19	21	31	33
	BH06	18	16	15	17	26	26	27	25	34	32	52	52
	BH07	7	11	11	11	21	13	18	16	21	21	33	34
	BH08	14	9	11	13	21	15	19	17	23	23	36	36
	BH09	16	13	14	14	25	22	24	23	29	28	47	46
	BH10	12	14	12	14	19	23	22	21	26	26	41	43
	BH11	10	8	10	8	15	15	13	15	18	18	30	28
	BH12	11	9	9	11	16	12	16	14	19	20	28	30
	BH13	11	11	9	11	18	16	18	14	22	20	34	32
	BH14	7	6	6	7	10	11	11	11	13	13	21	22
	BH15	11	12	11	12	15	19	18	16	23	23	34	35
	Min	7	5	5	5	10	9	9	10	12	10	19	19
	Max	18	16	15	17	26	26	27	25	34	32	52	52

## EVALUATION OF SAMPLING BIAS - DIAMOND DRILL CORE SAMPLES VERSUS PERCUSSION DRILLING BLAST HOLE SAMPLES.

Fifteen (15) HQ (63.5mm) sized conventional diamond drill cores were drilled at no further than 0.7 meters away from the percussion drilling blast holes to a depth fifteen (15) meters to provide a direct comparison against the individual blast holes assay results. The diamond drill core recoveries were logged to be 98-100% across the sample widths.

Investigating the sampling bias and the changing transient nature requires a reference sample that is correct, and not affected by an Increment Delimitation Error (IDE) nor an Increment Extraction Error (IEE). As part of the extraction error, the possible "plucking effect" of copper sulphides should be mentioned as potential for low recovery of sulphides species in diamond drill core samples. This possible effect on typical Antapaccay ore has not been reported by the geologists during logging of the diamond drill cores and is considered to be minimal due to the finely disseminated sulphides as well as the compact and unweathered intrusive nature of the orebody.

### DIAMOND BORE CORE SAMPLE PREPARATION PROTOCOL

The bore core samples preparation protocol is as follows:

- As per standard procedure the diamond core is divided into 2.5 meters intervals for sampling and chemical analysis. Each individual diamond drill core provides seven (7) separate assay samples that are averaged for the entire profile.

- The diamond drill core is split 50% using a rotary diamond saw into A and B samples following geologist instructions after logging.
- Complete crushing/reduction of the A sample core samples to less than three (3) millimeters using a conventional jaw crusher and divided using a rotary sample divider to approximately 600 grams of sample
- The samples are pulverized/reduced using an Essa® LM2 single disk type mill to a nominal top size of 106 micron.
- Pulverized samples are divided via incremental division for chemical and repeat/reserve purposes.
- The reduced samples are homogenized, divided and assayed individually using the mine's site laboratory routine internal procedures consisting of a four-acid digestion and Atomic Absorption Spectroscopy (AAS) measurement with standard quality control procedures, including appropriate internal and external reference materials

### DIAMOND DRILL CORE SAMPLES DATA ANALYSIS

The mine geologists consider 2.5 meters sampling interval appropriate for the finely disseminated copper mineralization. This investigation involved fifteen (15) diamond drill holes and subsequently 115 samples for copper analysis. The histogram of the copper demonstrated a significant skewness to the grade data (Figure 11).

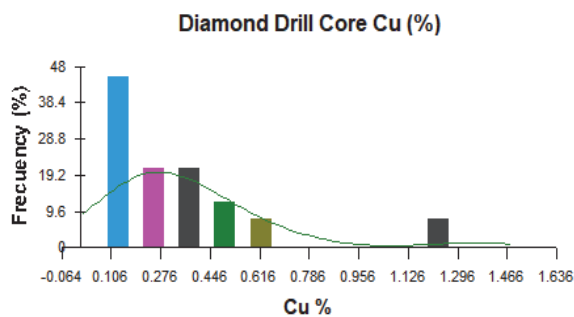

Count	115
Average copper %	0.53
Standard deviation	0.479
Coeff. of variation	90.10%
Minimum value	0.06
Maximum value	3.16
Range	3.10
Standard skewness	9.3
Standard kurtosis	2.5

**Figure 11.** Plot of the diamond drill core 2.5-meter sample interval copper results for all data (n=115).

The average copper grade of each diamond drill hole is calculated as the weighted average copper grade from the length of bore core samples. The sampling bias evaluation is performed by comparing the data of percussion blast hole drilling template No. T9, the sectional frame sample and the diamond bore core data for each fifteen (15) sampling locations. As the samples collected from the rotary percussion drill chips are considered potentially to be biased the sampling template takes into account only the precision.

In summary, the bias of blast hole drill chips sampling (Reference Template) versus the diamond drill core is 26.7% as a median, because the distribution is not normally distributed (Table 5).

Even though the bias of the sectional metal frame sampling method does improve the sampling relative to the bore core assay data (relative difference 12% versus 26.7%). It is however not practical to perform this sampling technique on a routine basis due to the large sample mass generated and significant time and resources required to collect the samples.



**TABLE 4.** Summary of diamond bore core, percussion blast hole chip reference template, template No. T9 and sectional frame total copper (TCu %) results for the fifteen (15) sampling positions.

Hole No.	Diamond Drill Core TCu %	Reference Template TCu %	T9 TCu %	Sectional frame		
				A TCu %	B TCu %	(A+B) TCu %
1	0.336	0.349	0.346	0.314	0.309	0.311
2	0.233	0.423	0.418	0.428	0.516	0.477
3	0.277	0.476	0.441	0.335	0.407	0.367
4	1.087	0.750	0.750	0.730	0.955	0.802
5	0.765	0.815	0.815	0.622	0.656	0.622
6	1.115	0.887	0.887	1.024	1.335	1.252
7	0.187	0.337	0.337	0.358	0.202	0.234
8	0.445	0.450	0.435	0.445	0.377	0.395
9	0.927	1.119	1.123	1.098	1.118	1.107
10	0.365	0.509	0.509	0.376	0.378	0.377
11	0.163	0.212	0.212	0.133	0.227	0.193
12	0.222	0.394	0.407	0.297	0.342	0.335
13	0.247	0.313	0.323	0.255	0.339	0.255
14	0.868	1.121	1.122	1.125	1.154	1.125
15	0.855	0.879	0.879	0.827	0.882	0.827
<b>Average</b>	<b>0.517</b>	<b>0.583</b>	<b>0.580</b>	<b>0.539</b>	<b>0.594</b>	<b>0.561</b>

**TABLE 5.** Summary of calculated sampling "bias" for blast hole chips, reference template, T9 template and sectional frame versus diamond drill core samples using the average copper content

Hole No.	Reference Template vs Diamond Drill Core (%)	T9 vs Diamond Drill Core (%)	Sectional frame (A) vs Diamond Drill Core (%)	Sectional frame (B) vs Diamond Drill Core (%)	Sectional frame (A+B) vs Diamond Drill Core (%)
1	4.0	3.1	-6.5	-8.0	-7.3
2	81.3	79.2	83.6	121.3	104.7
3	72.1	59.4	21.1	47.1	32.5
4	-30.9	-30.9	-32.8	-12.1	-26.2
5	6.5	6.5	-18.8	-14.2	-18.8
6	-20.5	-20.5	-8.2	19.7	12.2
7	80.1	80.1	91.1	7.8	25.1
8	1.0	-2.4	-0.1	-15.4	-11.4
9	20.8	21.2	18.5	20.7	19.5
10	39.6	39.6	3.1	3.7	3.5
11	30.4	30.4	-18.3	39.5	18.6
12	77.9	83.5	34.0	54.3	51.0
13	26.7	30.7	3.1	37.0	3.1
14	29.2	29.4	29.7	33.0	29.7
15	2.8	2.9	-3.3	3.2	-3.3
<b>Median</b>	<b>26.7</b>	<b>29.4</b>	<b>3.1</b>	<b>19.7</b>	<b>12.2</b>

## DISCUSSION

The manual sampling of rotary percussion drill blast hole drilling chips has several sampling errors potentially compromising its use as a grade control tool. These inherent errors are due to variable drilling chip recovery, loss of the fine fraction as dust or washed out by water, over sampling outside the drill hole dimensions and irregular segregation of density and size fractions. However, there is still an operational requirement to utilise these blast hole samples for grade control, so it is imperative to try to obtain acceptable and unbiased data as well as to manage cost constraints and production blast cycle times.

The tested forty (40) increment sampling template allows the identification of the distribution of the copper grades within the cone of drilling chips. This data allows the design of an appropriate sampling template with the highest practical precision and manageable mass of samples. The versatility of this template permits the simulation of different sampling templates by reducing the number of increments and weight of samples for a required sampling precision.

The contouring of the copper grades from the individual increments demonstrated a substantial irregular and unpredictable distribution of copper concentration within the blast hole chips which are at times is significantly higher (>10 times) than the average copper grade of the blast hole. This extreme variability in copper distribution cannot be identified without this tool and demonstrates the complexity and susceptibility to bias and poor precision if the copper grade distribution is not fully appreciated. The unpredictable distribution of the copper grade within the cone of blast hole chips indicates that the most appropriate increment sampling template is a cross-shaped pattern that collects samples radially in four directions (the first increment collected perpendicular to the drill rig position - see Figure 2). In addition, this template can also be rotated 45 degrees for duplicate sampling and to verify that the relative reproducibility difference is less than 5%.

Collecting incorrect or biased samples for analysis has a significant impact on grade control, metal reconciliation and incorrect classification of ore and waste. Other sampling procedures including sampling with a sectorial metal frame are not precise, reproducible and creates significant uncertainty in selecting the samples. The diamond drill cores are considered the best available reference samples to verify the inherent sampling bias generated by various other blast hole chip sampling methods. As indicated in the literature, bias is not a constant variable, therefore, the test results are the best estimator for the variables considered in this work.

## GOOD OPERATING PRACTICES FOR BLAST HOLE DRILLING AND CONE FORMING

Rotary percussion blast hole drilling with manual sampling of the drilling chips based on the field observations, analytical results and observed copper grade distributions, the following improvements are suggested:

- Maintain the vertical orientation of the drill rig to avoid circular eccentric movements that affect the recovery and size/density segregation of chips removed by the compressed air.
- Keep the skirts of the bore hole machines in good condition - they should be square, uniform and with the canvas covers to reduce the loss of fines and to ensure a circular and more uniform formation of the cone of drill chips
- Drain and dewater the benches before drilling as water ingress is the most important factor impacting segregation and poor recovery of drilling chips. The finer particles are washed out by water in benches and increases the size segregation and concentration of sulphide species.

## REFERENCES

1. B. Sproull, *“Theory of Constraints, Lean, and Six Sigma Improvement Methodology- Making the case for Integration”*, first edition, 283p (CRC Press, Taylor and Francis Group). 2019
2. I Clark and S C Dominy “Underground bulk sampling, uniform conditioning and conditional simulation – unrealistic expectations?”, in *Proceedings 8th World Conference on Sampling and Blending (WCSB8)*. 9–11 May 2017 Perth, Australia, pp. 3–19 (2017).
3. IS C Dominy “Sampling coarse gold-bearing mineralisation – developing effective protocols a case study from the Ballarat mine, Australia, in *Proceedings 8th World Conference on Sampling and Blending (WCSB8)*. Perth, WA, pp. 71–84 (2017).
4. F.F. Pitard, “Integration of Visman and Ingamell’ works into the Theory of Sampling – a necessity to expand

- possibilities in sampling practices”, in *Proceedings 8th World Conference on Sampling and Blending (WCSB8)*. Perth, WA, pp. 55–62 (2017).
5. N. S. De la cruz Bustamante, “*Geología de los cuadrángulos de Velille, Yauri, Ayaviri y Azángaro, Hojas: 30-s, 30-t, 30-u y 30-v*” – [Boletín A 58]. 1995.
  6. F.F. Pitard, “Blasthole sampling for grade control: the many problems and solutions”, in *Pierre Gy's Theory of sampling and Ingamells' Poisson process approach: Pathways to representative sampling and appropriate industrial standards*, Doctoral Thesis. Aalborg University, Denmark, pp. 213 - 235 (2009).
  7. F.F. Pitard “Sampling Theory and Sampling Practice”. *Textbook published by CRC Press, Inc.*, 2000 Corporate Blvd., N.W. Boca Raton, Florida 33431. Third edition, January 2019
  8. K. Engstrom and K.H. Esbensen, “Blasthole sampling (replicate and variographic experiment) in LKAB open pit iron ore mines – fit-for-purpose representativity?”, in *Proceedings 8th World Conference on Sampling and Blending (WCSB8)*. Perth, WA, pp. 85–95 (2017).

## ACKNOWLEDGEMENTS

The authors would like to acknowledge the Antapaccay Mine management for authorization to use the data generated during the last four years in searching for the best way to collect blast hole samples. Our gratitude to the field and ore control geologists, mine planners, samplers, chemical laboratory personnel and to everybody else who has been involved in this study.

**Appendix 1-** Sampling templates for simulation and determine the best sampling templates with <5% relative difference to the reference 40 position template.

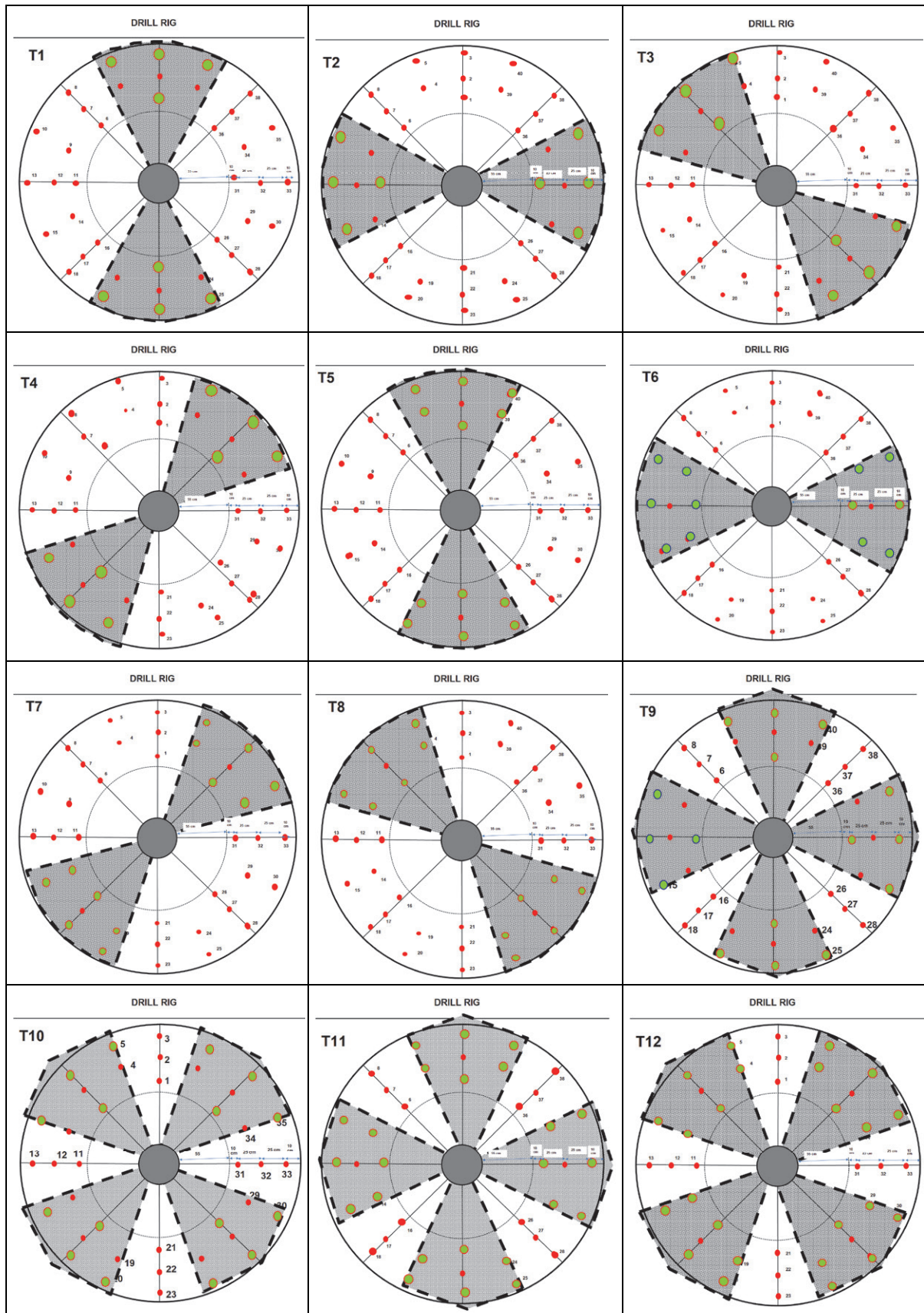



## Case studies using Visman and Ingamells sampling approaches

F. F. Pitard<sup>a</sup>

Francis Pitard Sampling Consultants, LLC, 14800 Tejon Street, Broomfield, Colorado, 80023, USA  
(E-mail: [fpssc@aol.com](mailto:fpssc@aol.com))

**It is an undeniable fact that Visman and Ingamells's works provide valuable additions to the Theory of Sampling. This paper shows real cases where their approaches gave valuable information to better understand the complex heterogeneity of low content constituents that led to better sampling and subsampling protocols. These case studies are:**

**Cobalt assays in a lateritic ore led to the conclusion that some areas were very low in cobalt content. A closer look at the data using Ingamells's approach proved that conclusion completely wrong.**

**The estimation of low content iron in high purity ammonium paratungstate using 1-gram subsamples for the analytical method proved to be affected by a severe Poisson Process giving the illusion of a product being within specification when in fact it was a very bad product.**

**It should be emphasized that there are probably thousands of similar cases in many industries, as the result of economists not communicating enough with knowledgeable technical staff.**

### Case study #1: A sampling diagram in a Nickel-Cobalt deposit

A lateritic nickel-cobalt deposit is drilled and assayed for its cobalt content which is an important by-product for the project. The drilling technique uses HQ-diameter tubing with a tungsten carbide drill-head, and the drilling is performed dry. Each sample is 1-meter long and weighs about 7500 grams. Some holes show very little cobalt but some others show attractive grade intercepts. Geologists were tempted to believe there were some areas much richer in cobalt than others. Table 1 shows 12 of these consecutive holes (there were many more but confidential). Each hole shows 12 consecutive 1-meter samples (there were many more but confidential). A mining test performed in the same area shown on table 1 followed by pilot plant pressure sulfuric leach reveals that the cobalt content was almost the same everywhere and slightly higher than expected. Retrospectively, looking at these existing exploration data, we may discover what created an unfortunate illusion.

Compositing horizontally

$$Q = 12$$

We obtain 12 horizontal composites leading to the following calculations.

Calculation of the Low Background Content for Cobalt

The harmonic means can be used to roughly estimate the Low Background Content<sup>1</sup>. Figure 1 shows the histogram of increasing cobalt contents, and the calculated value for the Low Background Content  $a_H$  (or  $L$  as defined by Ingamells), and a value of 0.03 % is used in the calculation of the sampling diagrams.

**Table 1. 12 holes in a lateritic nickel-cobalt deposit. The horizontal axis shows consecutive holes, while the vertical axis shows consecutive 1-meter samples. Assays are expressed in % cobalt.**

0.03	0.10	1.07	0.64	0.34	0.14	0.09	0.16	0.21	0.20	0.28	0.22
0.07	0.20	0.16	0.24	0.20	0.24	0.25	0.36	0.73	2.42	0.81	0.53
0.02	0.02	0.03	0.41	0.31	0.46	0.29	0.33	0.28	0.41	0.35	0.11
0.09	0.04	0.04	0.03	0.09	0.08	0.09	0.12	0.50	0.28	0.09	0.47
0.02	0.03	0.05	0.28	0.23	0.33	1.01	0.17	0.10	0.07	0.03	0.08
0.11	0.22	0.21	0.24	0.21	0.20	0.20	0.20	0.21	0.18	0.14	0.13
0.05	0.04	0.04	0.03	0.03	0.04	0.04	0.03	0.05	0.10	0.16	0.12
0.02	0.02	0.01	0.03	0.01	0.02	0.06	0.05	0.08	0.17	0.35	0.28
0.02	0.02	0.03	0.03	0.05	0.03	0.02	0.03	0.03	0.08	0.09	0.05
0.02	0.02	0.03	0.02	0.08	0.14	0.12	0.30	1.34	1.04	0.50	0.27
0.02	0.02	0.02	0.02	0.02	0.02	0.04	0.07	0.12	0.16	0.30	0.43
0.20	0.26	0.17	0.12	0.12	0.10	0.22	0.23	0.27	0.29	0.22	0.18

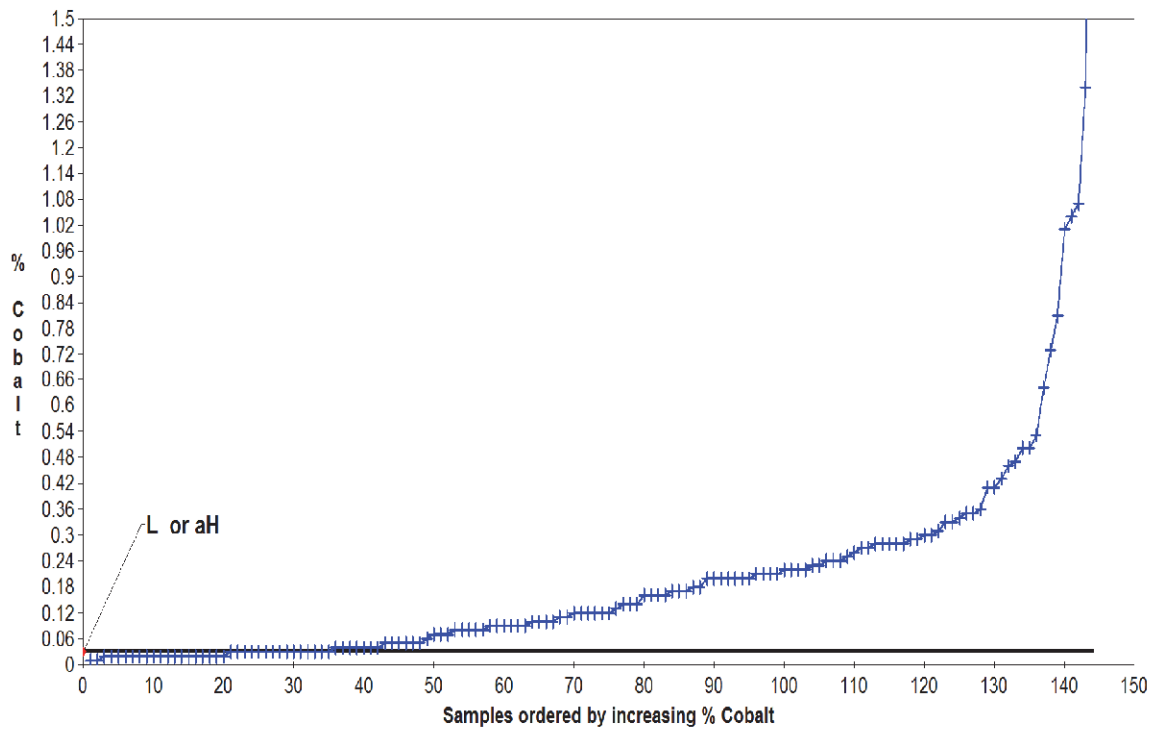

**Figure 1. Calculation of the Low Background Content.  $L$  is Ingamells' nomenclature used in the software.  $a_H = L = 0.03\%$**

**Calculation of the Most Probable Result**

The most probable result of an assay  $\gamma$  is calculated using formula [1] and shown in figure 2. We may observe that a single 7500-g sample gives a most probable result halfway between the estimated overall average content and the estimated Low Background cobalt content. It takes the averaging of 73 samples to eliminate the Poisson skewness.

$$\gamma = \frac{2a_L(a_L - a_H)^2 M_S + a_H \cdot IH_L \cdot a_L^2}{2(a_L - a_H)^2 M_S + IH_L \cdot a_L^2} \quad [1]$$

*Comment about the Ingamells' nomenclature:* we could use the TOS nomenclature for unknown values (i.e.,  $\gamma$ ,  $a_L$ ,  $a_H$ ) or the corresponding Ingamells' estimated value  $L$  instead of  $a_H$ .



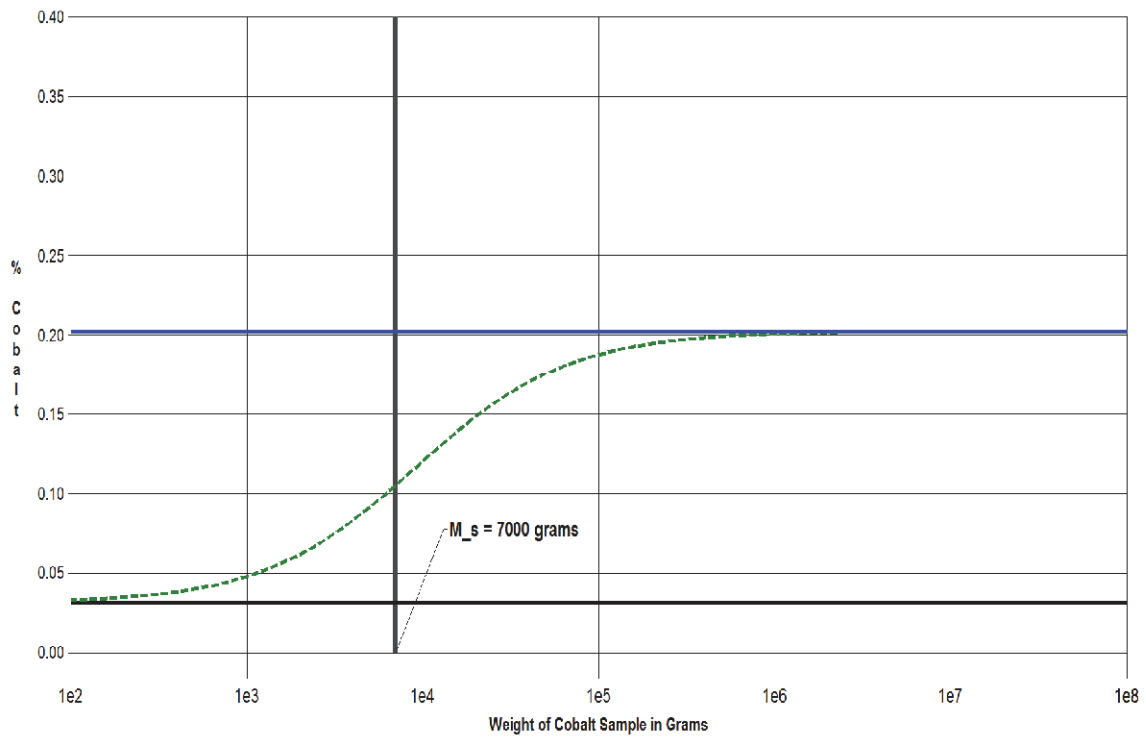

**Figure 2. Calculation of the Most Probable Result  $\gamma$ , illustrated as the dashed line. The low background content is the lower solid line. The overall arithmetic average is the upper solid line.**

**Calculation of standard deviation of the Fundamental Sampling Error**

The calculation of the standard deviation of the Fundamental Sampling Error is performed using equation [2] and it is shown in figure 3. Using equation [3] we may observe that the calculated *Minimum Sample Mass*  $M_{S\min}$  is about 20 kg, which is much larger than the basic drilling support set at 7 kg. Furthermore, following the guideline given in Pitard’s textbook<sup>1</sup> it would be unwise to collect a sample with less than a  $\pm 16\%$  relative for the standard deviation of the *FSE* which leads to the collection of a 500-kg sample (71 x 7 kg). Of course, such sample can only be obtained by averaging neighboring samples until the required mass is obtained. Nevertheless, if no such averaging is performed, the Poisson Process will most certainly create very unfortunate illusions, and this is exactly what happened during the exploration and preparation of the geological block model.

$$s_{FSE} a_L = \sqrt{\frac{IH_L \cdot a_L^2}{M_S}} \tag{2}$$

$$M_{S\min} = \frac{IH_L \cdot a_L^2}{[a_L - a_H]^2} \tag{3}$$

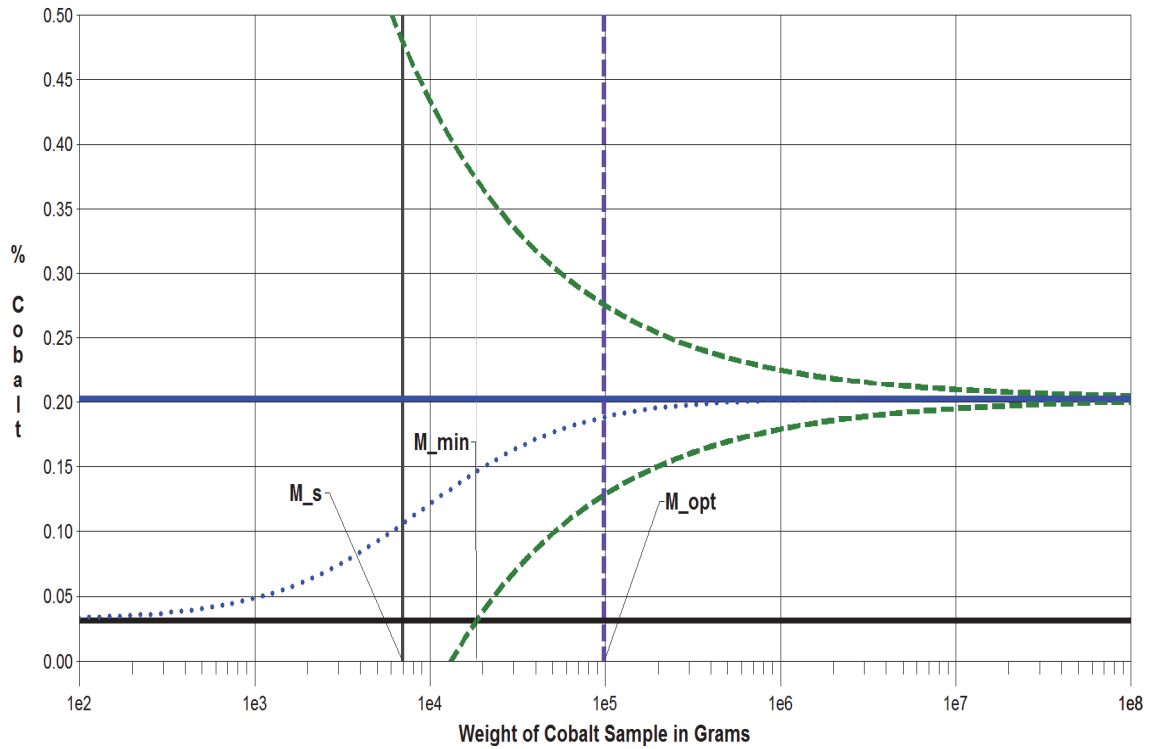

**Figure 3. Calculation of the standard deviation  $s_{FSE} a_L$**

The Optimum Sample Mass  $M_{Sopt}$  is calculated using equation [4]. It is a compromise between  $FSE$  (necessary sample mass) and  $GSE$  (necessary number of samples to account for field segregation). In figure 3 it is shown to be about 100kg.

$$M_{Sopt} = \frac{IH_L}{s_{SE}^2} \tag{4}$$

**Conclusion:** It would be extremely unwise to collect samples smaller than 100kg, which confirms that drilling with reverse circulation or large diameter percussion into relatively soft laterites would have been a much better option.

**Calculation of the standard deviation  $s_{opt}$  according to the Optimum Sample Mass**

The calculation of the standard deviation  $s_{opt}$  is performed using equation [5], and it is shown in figure 4. As suggested in the graphic, the significance of  $s_{opt}$  is meaningless below the Optimum Sample Mass, which is about 100 kg when using equation [4]. In other words, it is practically impossible to draw a logical geological block model using the information from 7-kg samples, unless a massive field moving average is used, which of course, in turn results in the loss of small-scale definition.

$$s_{opt} = \sqrt{\frac{2IH_L \cdot a_L^2}{M_S}} \tag{5}$$

Calculation of the standard deviation of a single assay  $s_{N=1}$

The calculation of the standard deviation  $s_{N=1}$  is performed using equation [6], and it is shown in figure 5.

The spread of  $s_{N=1}$  as the sample mass becomes very large gives an indication of the amount of large-scale segregation that was present in the field in the area under study, which is anywhere between 0.12% and 0.28% cobalt. This domain is where Geostatistics should perform very well. Now the Ingamells' sampling diagram is complete, and as presented it is reasonably consistent with the TOS. We may debate the accuracy of the information, nevertheless, it is obvious the sampling diagram contains enormous amount of valuable information, and it is the general message that counts to select a reasonable field sampling strategy.

$$s_{N=1} = \sqrt{\frac{IH_L \cdot a_L^2}{Ms} + s_{SE}^2 \cdot a_L^2} \tag{6}$$

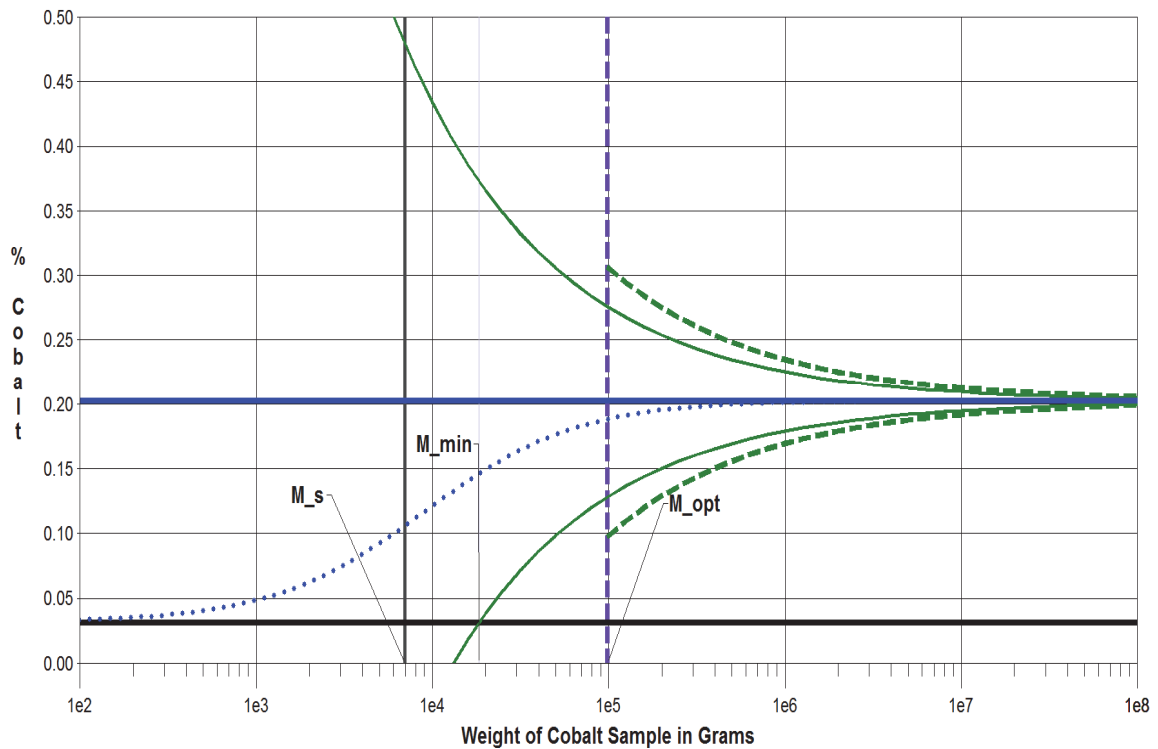
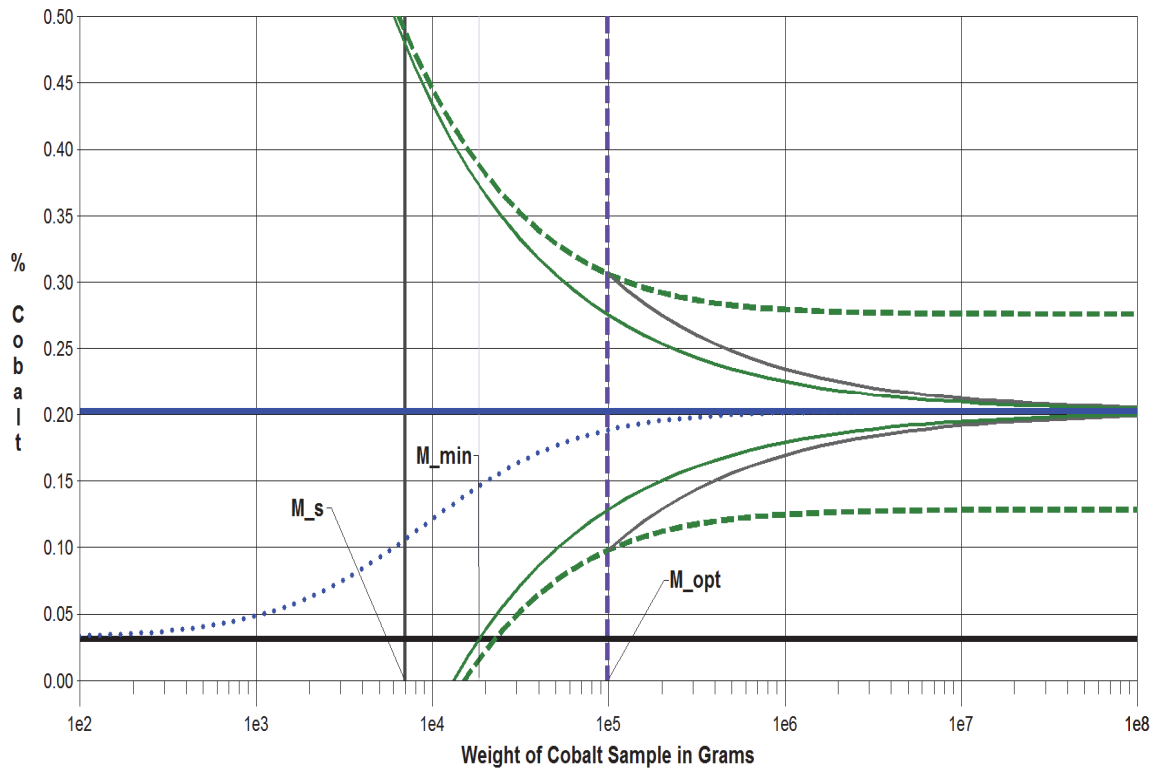

Figure 4. Calculation of the standard deviation  $s_{opt}$  illustrated as the dashed curves.

A similar study can be performed by compositing data vertically which can give valuable information when compared to compositing horizontally and show which preferential orientation the field segregation is.



**Figure 5. Calculation of the standard deviation  $s_{N=1}$  illustrated as the dashed curves.**

### Case study #2: Estimation of the iron content in high-purity Ammonium Paratungstate

The following case study involves a single stage Poisson Process. The economic consequences can already be imagined because of the non-representative assessment of the impurity content of an extremely valuable high purity material. It should be emphasized that the analytical protocol that was used was categorized as fast, cheap, and convenient. In other words, it was called a *cost-effective* analytical method. It should be emphasized that there are probably thousands of similar cases in many industries, as the consequence of economists not communicating enough with knowledgeable technical staff.

Following a dispute between the supplier and the customer a recommended test was performed. A typical 5000-g lot was assayed 80 times using the standard 1-g assay sample weight used at the supplier’s laboratory. Table 2 shows all the assay values generated for this experiment.

A summary of results is as follows:

The estimated average  $\bar{x} \approx a_L$  of the 80 assays was 21 ppm.

The absolute variance  $s^2 = 378 \text{ ppm}^2$

The relative, dimensionless variance  $s_R^2 = 0.86$

The absolute standard deviation  $s = 19 \text{ ppm}$

The relative, dimensionless standard deviation  $s_R = 0.93$  or 93%

Table 2. Summary of 80 replicate iron assays in high-purity ammonium paratungstate

Sample number	ppm Fe	Sample number	ppm Fe	Sample number	ppm Fe	Sample number	ppm Fe
1	4	21	44	41	5	61	28
2	20	22	21	42	31	62	4
3	21	23	21	43	19	63	21
4	31	24	18	44	6	64	29
5	16	25	21	45	18	65	20
6	16	26	4	46	18	66	35
7	14	27	17	47	4	67	19
8	12	28	32	48	4	68	48
9	4	29	7	49	5	69	4
10	9	30	18	50	4	70	14
11	36	31	20	51	19	71	8
12	32	32	21	52	6	72	6
13	31	33	4	53	44	73	115
14	4	34	19	54	74	74	4
15	22	35	32	55	16	75	9
16	4	36	4	56	4	76	13
17	4	37	64	57	33	77	26
18	19	38	7	58	4	78	32
19	48	39	48	59	34	79	4
20	68	40	18	60	64	80	12

It should be emphasized the above variances and standard deviations were calculated using conventional formulas, which may not be a very good thing to do when a Poisson Process is taking place.

From the TOS we can write the following relationship:

$$\frac{s_1^2}{a_L^2} = s_{FSE1}^2 + s_{GSE1}^2 = \left[ \frac{1}{M_{S1}} - \frac{1}{M_L} \right] IH_L + s_{FSE1}^2 \gamma \xi^2 \quad [7]$$

All terms are well defined in the TOS. The subscript 1 refers to the only information we have from a small sample weighing 1g. The effect of  $M_L$  is negligible since it is very large relative to  $M_S$ .

We don't know the value of the variance  $s_{GSE1}^2$  of the Grouping and Segregation Error; however, the material is well calibrated and there are no reasons for significant segregation to take place, and the isolated grains containing high iron content have about the same density as the other grains since their composition is mainly ammonium paratungstate. Therefore, we may assume in this particular case that  $s_{FSE1}^2 \geq s_{GSE}^2$  if each 1-g sample is made of several random increments, so the value of  $IHL$  we may calculate is only slightly pessimistic. We may write:

$$0.86 - s_{GSE}^2 \approx IH_L \quad [8]$$

We may therefore assume that  $IHL \leq 0.86$  g. If the tolerated standard deviation of the  $FSE$  is 16% relative, we may calculate the optimum necessary sample mass  $M_S$ :

$$M_S = \frac{0.86}{(0.16)^2} = 34g \quad [9]$$

Obviously, it is a long way from the 1-gram that was used for practical reasons. This mass of 34 grams is the minimum sample weight that will ensure a normal distribution of the assay results. Another parameter that can be obtained is the low background content  $a_H$  which is probably around 4 ppm as suggested by the histogram in figure 6. This high-frequency low value may sometimes represent only the lowest possible detection of the analytical method; therefore, we should remain cautious as we define the true low background content of a product for a given impurity.

#### Investigation of the histogram

Figure 6 illustrates the histogram of  $N = 80$  assays shown in table 2. In this histogram it is clear that the frequency of a given result reaches a maximum at regular intervals, suggesting that we may class the data in various zones; zone A with 27 samples showing zero grain with the iron impurity; zone B with 29 samples showing 1 grain; zone C with 13 samples showing 2 grains; zone D with 5 samples showing 3 grains; zone E with 3 samples showing 4 grains; zone F with 1 sample showing 5 grains; Zone G with 6 grains shows no event; finally zone H with 7 grains shows one event, which may be an anomaly in the model of the distribution. The set of results appears Poisson distributed, and a characteristic of the Poisson distribution is that the variance is equal to the mean:

$$s^2 = a_L = 21 \text{ ppm} = 1.18 \text{ grain / sample} = \theta \quad [10]$$

The assumption that  $a_H = 4$  ppm needs to be checked. The probability that the lowest assay value represents  $a_H$  can be calculated. If the average number of grains showing the impurity per sample  $\theta$  is small, there is a probability that the lowest assays represent  $a_H$ . The probability that a single collected sample will have zero grain is:

$$P(x = 0) = \frac{\theta^0 e^{-\theta}}{0!} = e^{-\theta} = e^{-1.18} \quad [11]$$

If we call  $P(x = 0)$  the probability for a success of obtaining no grain with the impurity, then the probability  $P_x$  of  $n$  successes in  $N$  trials is given by the binomial model:

$$P_x = \frac{N!}{n!(N-n)!} P^n (1-P)^{N-n} \quad [12]$$

where  $P$  is the probability of having a sample with no grain containing the impurity when only one sample is selected, and  $(1-P)$  is the probability of having at least one grain when only one sample is collected; then the probability of no success  $P(x \neq 0)$  with  $N$  samples is:

$$P(x \neq 0) = \frac{N!}{0!(N-0)!} (e^{-\theta})^0 (1 - e^{-\theta})^{N-0} = (1 - e^{-\theta})^N \quad [13]$$

Relation [13] shows the probability that none of  $N$  samples is free from low-frequency impurity grains. The probability that the lowest assay value represents  $a_H$  is:

$$P(x = 0) = 1 - (1 - e^{-\theta})^N = 0.9999 \quad [14]$$

Assuming that  $a_H$  is not the analytical detection limit, we can be sure that the lowest assay represents  $a_H$ . Having found that the value  $\theta = 1.18$ , we may calculate the Poisson probabilities for samples located in each zone illustrated in figure 6. Thus, by multiplying each probability by 80, we may compare the calculated distribution with the observed distribution. Results are summarized in table 3.

The observed distribution is very close to the calculated distribution if we exclude the very high result showing 115 ppm which should not have appeared with only 80 samples. A characteristic of the Poisson distribution is that the variance  $s^2$  of the assays is equal to the average  $a_L$ .

$$s^2 = \bar{x} \approx a_L = \theta \quad [15]$$

or

$$s = \sqrt{\theta} \quad [16]$$

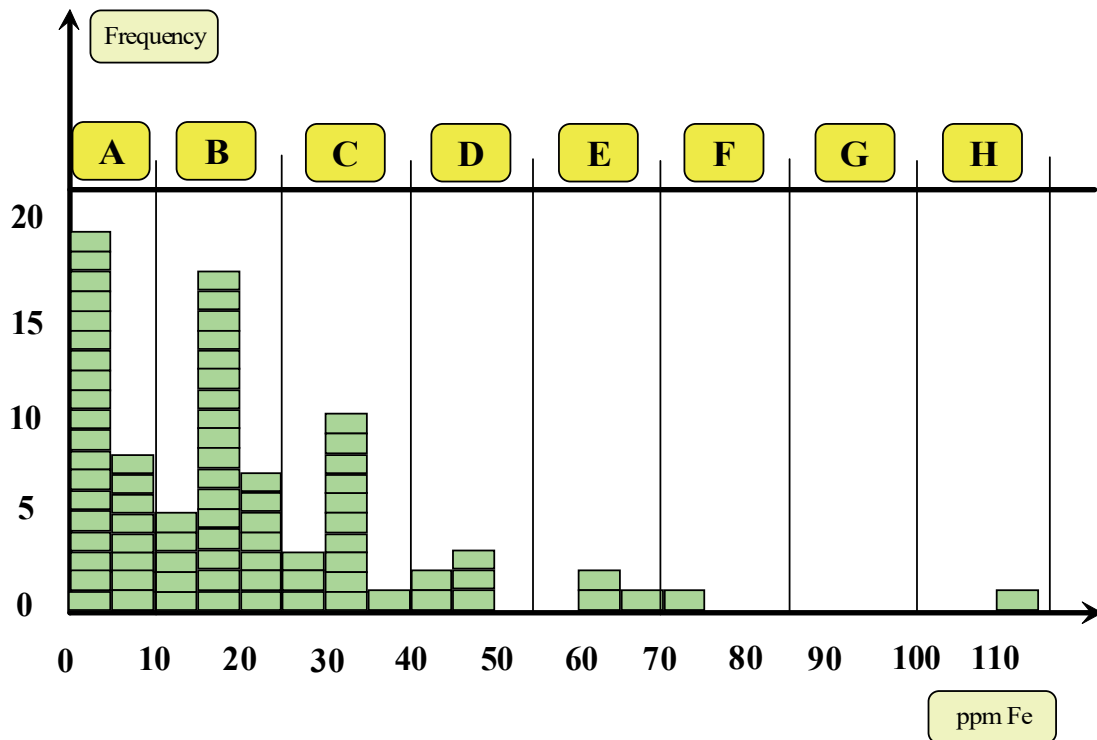

Figure 6. Histogram of eighty 1-gram assays for iron in ammonium paratungstate

But, in practice the number of grains is not used; instead, concentrations are used such as %, g/t, ppm, or ppb. Let's call C the conversion factor and rewrite [16] properly:

$$s = C\sqrt{\theta} \tag{17}$$

Thus, we may calculate the contribution C of a single average impurity grain to a single iron assay:

$$C = \frac{21}{\sqrt{1.18}} = 19 \text{ ppm} \tag{18}$$

Table 3. Comparison of the calculated distribution with the observed distribution

r	Poisson probability for $\theta = 1.18$	Calculated distribution	Observed distribution
0	0.307	25	27
1	0.363	29	29
2	0.213	17	14
3	0.084	7	5
4	0.025	2	3
5	0.006	0	1
6	0.001	0	0
7	0.0002	0	1
<b>Total</b>	<b>0.999</b>	<b>80</b>	<b>80</b>

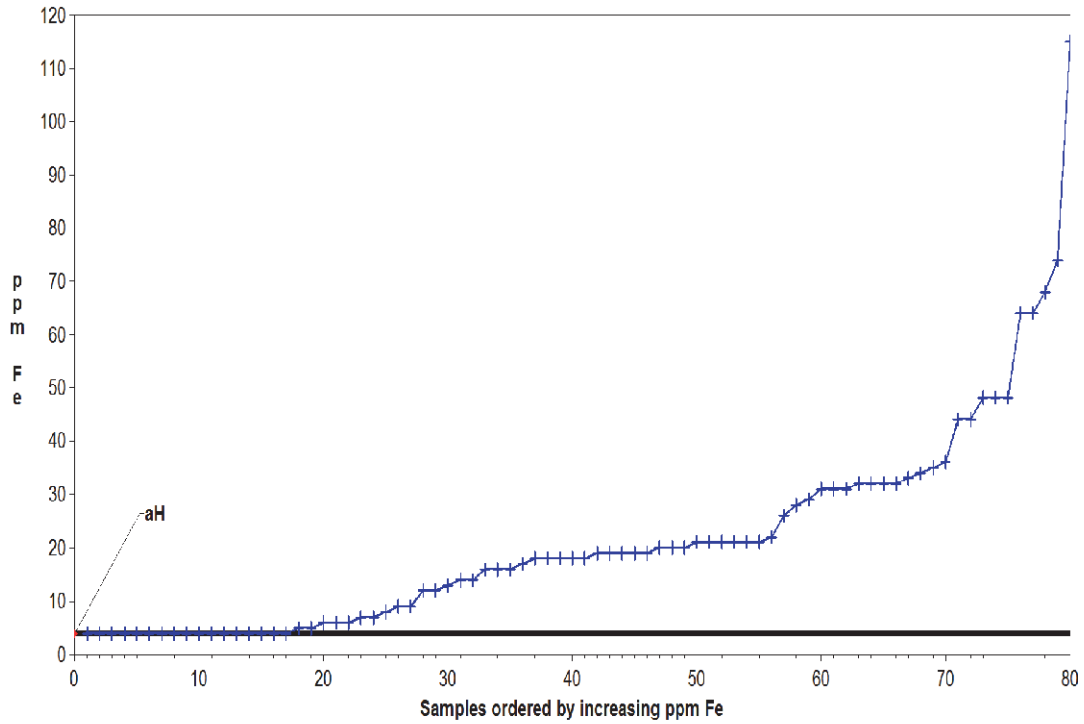

**Figure 7. Histogram of the 80 assays ordered by increasing iron content**

Discussion of acceptable maximum for the standard deviation of the *FSE*

Ingamells suggested that a minimum of six of the grains showing the impurity, or a cluster of this impurity, should be present in a sample for the analysis of this sample to be meaningful. The objective of such recommendation is to eliminate the Poisson Process from damaging the database. If a 1-g sample contains an average  $\theta = 1.18$  grains, then the minimum recommended sample mass is around 5 g. Using this mass and the value of  $IHL$  obtained earlier we may write:

$$s_{SFE}^2 \leq \frac{0.86}{5} = 0.17 \tag{19}$$

$$s_{SFE} \leq 0.41 \quad \text{or} \quad 41\% \text{ relative} \tag{20}$$

But, following Gy's recommendations a 34-gram sample is recommended to achieve a 16% relative standard deviation, which would contain about 41 grains. Now, how can 5-g leading to 41% relative and 34-g leading to 16% relative be reconciled?

To further discuss this difference, let's construct the useful Ingamells' sampling diagram. With the set of data given in table 2 a set of artificial, large 10-g samples made of  $Q=10$  small one-gram samples can be created, and they are shown in table 4.



**Table 4. Iron content of artificial large samples of mass equal to 10 g**

N sample number	Composited small samples	Iron content in large samples
1	1-10	15
2	11-20	27
3	21-30	20
4	31-40	24
5	41-50	11
6	51-60	30
7	61-70	22
8	71-80	23

Visman sampling equation

With this information Visman sampling constants A and B can be calculated:

$$S^2 = \frac{s^2}{N} = \frac{A}{M_s} + \frac{B}{N} \quad [21]$$

where S is the uncertainty in the average of  $N=80$  assays on samples of individual mass  $M_s^* = \frac{M_s}{N} = 1g$ . [22]

A is the Visman homogeneity constant. It is the Gy's Intrinsic Constitution Heterogeneity  $IH_L$  multiplied by the square of the average content of the lot.

From the variances and Visman's equation we obtain:

$$A = IH_L \cdot a_L^2 = \frac{(s_1^2 - s_2^2)M_{s1}}{a_L^2 \left(1 - \frac{1}{Q}\right)} = 379773mg / ppm^2 \quad [23]$$

From Gy we suggested earlier:

$$A = IH_L a_L^2 = 0.86(21.475)^2 = 396611mg / ppm^2 \quad [24]$$

Those numbers are very close and within the variances precision, therefore this would suggest there is no room to calculate the amount of segregation for iron in the lot. It is wise to assume that B, the Visman segregation constant, is:

$$B = s^2 - \frac{A}{M_s^*} = s_{GSE}^2 a_L^2 N = s_{SE}^2 a_L^2 \approx 0$$

This confirms the opinion that iron in calibrated ammonium paratungstate grains has no reason whatsoever to segregate in a substantial way, as the iron is within ammonium paratungstate salt anyway, and all the observed variability is due to the variance of  $FSE$ .

#### The Most Probable Result

The Most Probable Result  $\gamma$  for the assaying of iron as a function of analytical sample mass  $M_s$  is calculated with Ingamells' equation 1. Values of  $\gamma$  are illustrated in figure 8 with the dashed line, and it basically represents the location of the mode of the probability distribution relative to the expected arithmetic average  $a_L$ .

A careful study of the  $\gamma$  curve in figure 8 (i.e., dashed curve) is the key to complete our discussion of the difference between Ingamells' recommendation and Gy's recommendation for a suggested maximum value for the standard deviation of  $FSE$ . It can be observed that the recommended mass by Ingamells (i.e., 6 grains in the sample) or a  $s_{FSE} = \pm 41\%$  relative leads to a location of the mode still substantially below the expected arithmetic average  $a_L$ . It is not the case with the necessary sample mass of 33 grams (i.e.,  $33 \times M_s$ ) to obtain a  $\%s_{FSE} = 16\%$  as recommended by Gy. In other words, Gy's recommendation was simply more conservative and less subjective to ambiguity.

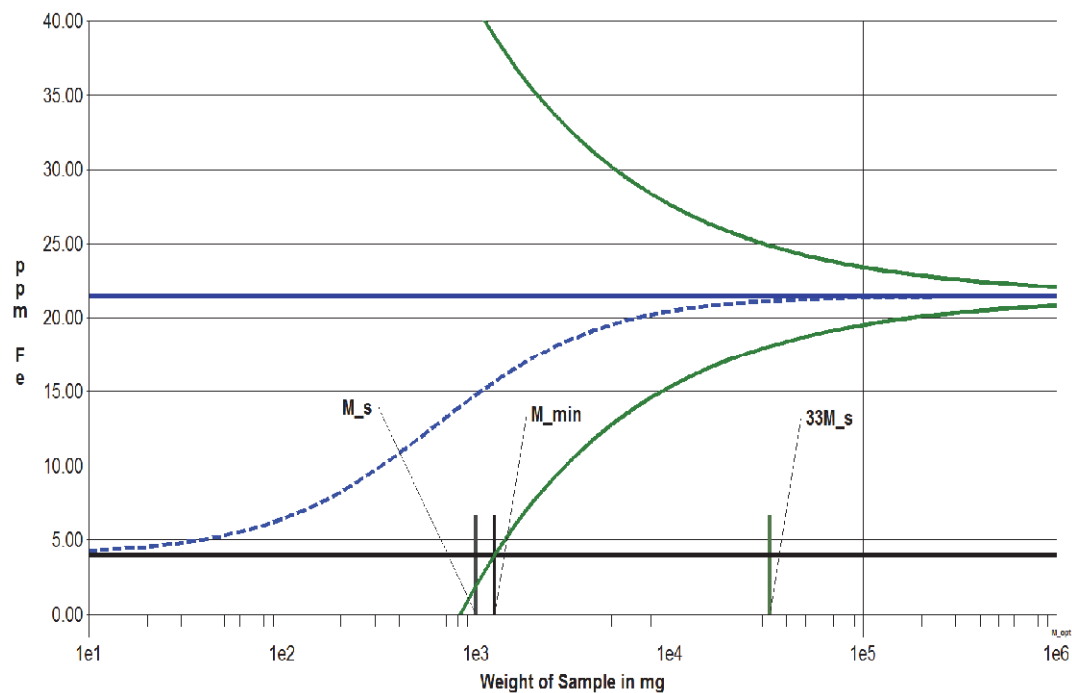

**Figure 8.** Illustration of the Ingamells' sampling diagram for ammonium paratungstate

## Conclusion and recommendations

Cases mentioned in this paper were already published in Pitard's textbook<sup>1</sup>. The only objectives of this paper is to emphasize sampling diagrams suggested by Visman and Ingamells that are not well understood by sampling practitioners around the world, though they can most certainly well illustrate complex sampling problems. Their proper use can help many industries such as, mining, industrial minerals, recycling, environment, food, pharmaceutical, etc...

Recommendations are:

1. Clearly understand the subtle occurrences of trace constituents of interest to make sure the potential for introducing a Poisson Process when collecting and assaying samples is prevented, or at least reasonably understood. This requires an in-depth understanding of chapters 14, 15, and 16 in Pitard's textbook<sup>1</sup>.
2. Sufficient data is generated to be able to make reliable statistical evaluations like those presented in this paper.
3. A thorough investigation of the preferred analytical method is necessary to reasonably make sure potential problems are indeed sampling problems and not analytical problems. Remember this famous quote from a brilliant analytical chemist<sup>2</sup> "The reliability of a result depends more on who produced it than on how it was done. There is no such a thing as a bad method, only bad analysts who fail to allow for its limitations."
4. The creation of a good, appropriate software package is necessary to generate relatively complex Ingamells' sampling diagrams.

Sampling practitioners will never regret the effort they made to acquire these valuable graphic tools.

## References

- [1] **Pitard, F.F.** (2019). Sampling Theory and Sampling Practice. *Textbook published by CRC Press, Inc.*, 2000 Corporate Blvd., N.W. Boca Raton, Florida 33431. Third edition, January 2019. Chapter 14.
- [2] **S. Abbey**, U.S. Geological Survey Standards, A Critical Study of Published Analytical Data. *Canadian Spectroscopy*, V.15, 10-16, 1970.

## ISO 13909 Compliant Contractual Payment Station Coal Sampling Plant: Process Design and Equipment Selection for Chemical, Physical and Moisture Sampling

---

M. Nyokong<sup>a</sup> and W.P. Slabbert<sup>b</sup>

<sup>a</sup>Email: [disen@multotec.com](mailto:disen@multotec.com)

<sup>b</sup>Email: [willems@multotec.com](mailto:willems@multotec.com)

---

The paper discusses the process design and mass balance highlights to illustrate the ISO 13909 compliance of a 4-year-running contractual payment station sampling plant. The plant is used to sample -60mm coal supply to a coal fired power station infrastructure belonging to the South African National Power Utility. Payment parameters are proximate analysis (Calorific Value, Ash-, Sulphur content), physical (size and abrasion index) and moisture content. Over and above ergonomic physical samples and timeous moisture samples, the plant also delivers the crushed chemical sample in triplicate for buyer-, seller- and referee analysis.

The lot period was defined as 24 hours production while the system compliance was designed around mass-based sampling. Production varies over a wide range of throughout tonnages from 800-3600 ton/h as dictated by complex boiler and silo operational requirements. The plant required a unique operational philosophy to adapt the number of primary increments (and corresponding time interval) per subplot size to the varying production rates which over a fix lot period results in varying lot size. Furthermore, a contractual grade, calibrated, 6-idler belt scale is used to measure the instantaneous conveyor load which in turn controls the cutter speed via a programmable logic controller (PLC) prompted variable speed drive (VSD) setpoint to sample fixed increment mass to represent fixed production mass interval.

The primary belt end crosscut sampler boasts a unique articulated joint design sample chute to fit down the high sample tract; eliminating the delineation errors associated with the previous competitor design.

**Keywords:** ISO 13909 compliant, Sampling Plant, chemical-, physical-, moisture sampling, time-based lot, mass-based sampling interval.

### Project Background.

One of the major National Power Utility Power stations in South Africa, which contributes to the South African energy grid, required a sampling plant payment station to be used in its off-take agreement with its fuel supplier.

Multotec supplied a full turnkey solution consisting of an ISO 13909 compliant sampling scheme design and custom-built sampling equipment. Since the project was not completed by the previously awarded competitor, there was already an existing building infrastructure onto which the sampling plant payment station had to be retrofitted and installed. Steinhaus and Minnitt (2014)<sup>1</sup> emphasize the difficulties encountered when implementing samplings solutions on an

already existing processing plant. In addition to the brown fields engineering challenges of fitting new sampling equipment into constrained building layouts, the following was also critical to the design and success of the project:

1. Sampling measurements for contractual payment according to ISO-13909 for the collection of Chemical, Physical and Moisture composite samples.
2. Mass based primary sample increment compared to a time-based Lot period with extraction of constant primary increment mass within mechanical cutter speed design limitations and over a large range of throughputs.
3. Triplicate Chemical Composite Samples to be collected for the seller, customer, and referee.

## Literature Review.

Holmes (2010)<sup>2</sup> mentions that sampling needs to be given the necessary attention to produce representative samples for analyses. It should be noted that Holmes (2010)<sup>2</sup> makes use of the words sampling not sampler, since a sampler is a piece of device, mechanical or not, that can be used to collect a sample from a moving stream or stationery lot. The word sampling is the science of collecting representative samples which includes, but not limited to the sampler, number of times the sampler takes increments, how the samples are collected, stored, and transported to the lab for analyses and ultimately how the samples are analyzed. It is important to notice the above cumulative deviations from an ideal sampling scheme design can be summarized into 10 sampling errors as per Theory of Sampling (TOS). The degree of error accumulation and nature of the errors are defined by the 10 sampling errors and can be classified as bias (accuracy deviation), precision (reproducibility) and ore variability. Therefore, the objective of any sampling exercise or protocol is to eliminate or minimize bias, standard deviation and minimize variance (Minnitt, 2007)<sup>3</sup>. Bias generating errors falls under the responsibility of the Sampling Equipment Manufacturer (SEM), however, variance (precision) can also be the sole responsibility of the SEM, provided that the variance information is available (i.e., in the form of a Nomogram).

The nomograph information is not always available for the specific ore of concern, as a result, ISO standards are normally referred to as a guideline for sampling of various bulk commodities (Steinhaus & Minnitt, 2014)<sup>1</sup>. Coal and Iron Ore commodities consist of comprehensive standards which can be obtained from the ISO committee and local standard organisations. According to Steinhaus and Minnitt (2014)<sup>1</sup>, the SEM needs to familiarize themselves with the critical aspects of each ISO standard which relates to minimum number of increments to be collected per lot or consignment, minimum mass to be collected per lot or consignment, minimum number of sub-increments per preceding increment, quality variations, precision levels achieved with each specific minimum mass collected per lot or consignment relative to the material nominal top size.

There are various standards applicable to the sampling of coal and coke which includes, but not limited to the below:

- ISO 13909:2016 which consists of 8 parts for coal and coke handling. Part 2, 3, and 4 relate to coal only, and Part 5 and 6 to coke only (ISO, 2016<sup>4</sup>).
- ASTM standards
  1. ASTM D 7430 – Standard practice for sampling of coal. The standard is normally used to calculate the number of primary sample increments to be collected per lot or consignment.
  2. ASTM D 2234 – Standard practice for collecting gross sample of coal.
  3. ASTM D 2013 – Standard for preparing coal samples for analysis.
- Australian standard – AS 4264, Coal and Coke Sampling procedures.

## Design Scheme for Contractual Payment Station - Coal Sampling Plant.

The design scheme guideline as outlined in ISO (2016)<sup>4</sup> was used to design the contractual payment station sampling plant. The input parameters required for the design was obtained from operational personnel at the power station and is listed in Table 1.

**Table 1. Sampling system design input parameters**

Parameter	Value	Units	Comments
Throughput per Belt (Maximum)	1800	tons/hour	
Throughput per Belt (Minimum)	800	tons/hour	
Material Top Size	60	mm	
Lot period	24	h	
Lot size (Maximum)	86 400	tons	
Lot size (Minimum)	38 400	tons	
Particle density	2.680	Ton/m <sup>3</sup>	
Chemical sample particle size to the lab	6	mm	This is the size fraction that is required by the lab for analytical analysis
PSD precision level	2	%	This precision level was provided by operational personnel and listed as a requirement
Sampling frequency	240	tons	Provided by operational personnel
Chemical analysis precision level	0.2	%	0.2 % ash precision level is required. No other elements such as Sulphur for example were specified. The SEM is aware that these other elements can be important to consider in the design scheme.
Frequency of collecting moisture samples	8	hours	
Frequency of collecting Chemical and PSD samples			

### Primary Sampler Sizing and Selection

The primary increments collected by two identical primary samplers are outlined in Table 2. This primary sampler boasts a unique articulated joint design sample chute to fit down the high sample tract; eliminating the delineation errors associated with the previous competitor design where a pendulum effect, resulting from the long cutter that had only been supported at the top, drive end. The articulated joint design (Figure 1) allowed additional supports, but more importantly facilitated triangulation of the main cutter and sample outlet pipe, making the sample length sturdier and allowing constant cutter speed through the stream (across the range of VSD set points).

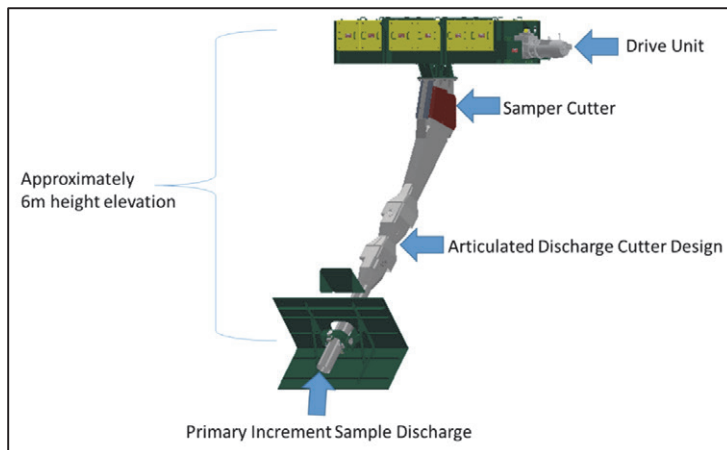

Figure 1. Primary Sampler Cutter with articulated discharge design

Table 2. Primary sampler specifications

Description	Units	Sampler 1/2
Sampler type	-	Falling stream
Cutter width	mm	180
Maximum Cutter speed	m/s	0.58
Number of increments per maximum Lot	number	360
Sampling frequency	tons	240
Primary increment size	kg/cut	310

The primary sampler increment mass can be calculated using equation 1, while the number of increments to be collected per 24-hour lot period was calculated using equation 2.

$$m_1 = \frac{Cb \times 10^{-3}}{3.6V_c} \quad (1)$$

Where:

$m_1$  = mass in kilograms

$C$  = flow rate in tonnes per hour

$b$  = cutter aperture in mm

$V_c$  = cutter speed in meters per second

$$N = \frac{t/d}{240t} \quad (2)$$

Where:

$N$  = Number of increments

$\frac{t}{d}$  = Daily consignment (tons)

$240t$  = Mass based sampling frequency (tons)

The mass-basis operation was chosen for the sampling scheme by the client. Since it is mass-basis sampling operation, the primary increment collected should be constant mass irrespective of conveyor A and B instantaneous

throughput at the 240t mark when it is time to take a sample increment. If the instantaneous conveyor loading is lower than the maximum loading, the cutter will be activated and traverse through the stream at constant speed with its sufficiently strong electromechanical drive system but result in an increment mass lower than the design increment mass and result in a weighting error. To achieve constant primary mass increment, each primary sampler is equipped with a VSD to adjust the sampler cutter speed – before the increment is initiated and then traverse through the stream at this predetermined set-point while maintaining constant velocity. Figure 2 shows the minimum cutter speed per belt throughput to achieve a constant primary increment of 310.0 $\pm$ 1% kg. The cutter speed is calculated by re-arranging equation 1 and making the cutter speed the subject of the formula.

Primary samplers were designed to ramp down to at least 0.13m/s minimum speed when the belt throughput is at 800tph, thus achieving 22% of the maximum speed. Below 20% of the full motor speed, the motor's cooling fan will not rotate fast enough to cool down the motor and can result in rotor winding insulation breakdown and motor failure. The minimum of 20% motor speed is ever more important where sampler drives are stopped and started drawing higher ampere than continuously running motor applications. To this extent a small forced cooled slave motor was added to the cowl cover of the master drive motor to ensure the motor is cooled. However, there is a throughput range lower limit below which the mechanical design rule of minimum 20% motor speed cannot be achieved and must be noted in sampling plant designs as a throughput range restriction.

According to ISO 13909, the mass variation on primary increment must be less than 20% however, the sampling plant is designed to extract a constant primary mass increment at variable primary cutter speed down to 800tph as shown in Figure 2 below.

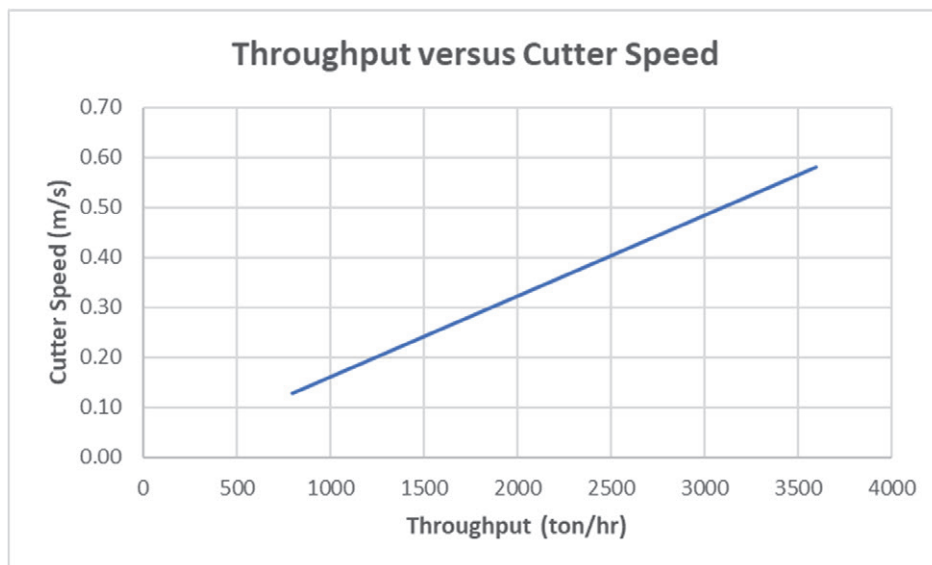

**Figure 2. Primary Sampler Cutter speed versus Conveyor Belt Throughput**



Process of combining increments into samples.

The primary increments collected by each primary sampler will be divided and transferred to the secondary sampler, a Rotary Tube Splitter (RTS), into three respective sample streams: chemical, moisture and Particle Size Distribution (PSD) in accordance with ISO (2016)<sup>5</sup>.

Figure 3 shows the block flow diagram of the sampling plant with the various process streams;\_chemical, moisture and PSD (Physical), including rejects handling by utilizing various sampling equipment which include rotating plate dividers (RPD), hammer mill impact crusher, turnstile divider.

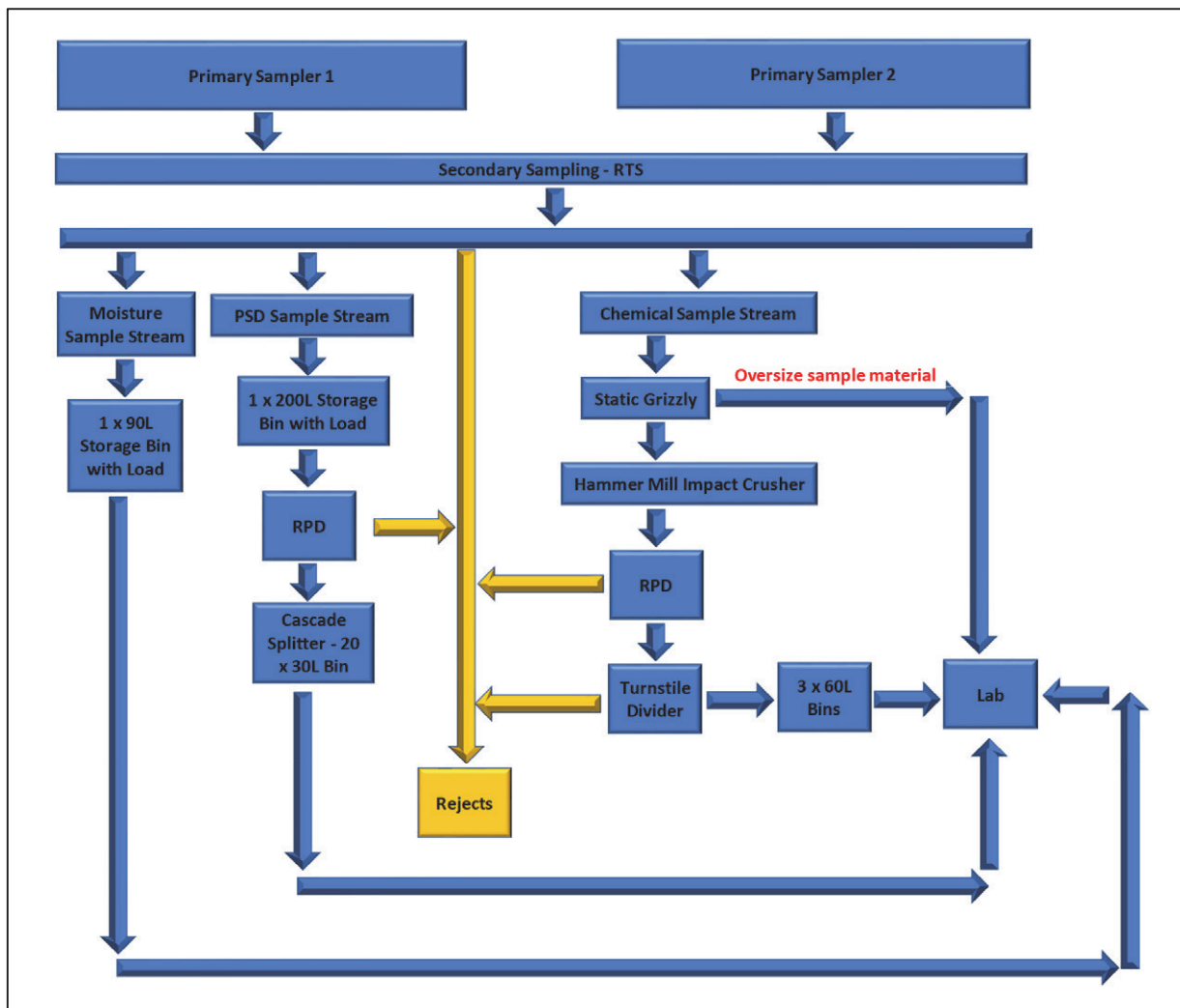

Figure 3: Sampling Plant – Block Flow Diagram

### Secondary Sampling

Each alternative primary sampler increment from Primary Sampler 1 and Primary Sampler 2 will be transported via the Primary Sample Feeder to report to the RTS. The secondary sampler, RTS is equipped with 3 cutters of 240mm width each (to cater for the 80mm oversize material), cutter tip speed of 0.22m/s and a sample division ratio of 11.1%, will

extract 2.85kg/cut per cutter, per primary increment. The RTS will take 12 sub-cuts per primary increment (exceeding ISO minimum requirements by 3 times) over a 2-minute processing time, yielding a 34.4kg secondary sample increment reporting to the physical, chemical, and moisture sample chutes. The remaining primary increment will report to the rejects chute. Both the physical and the chemical primary chutes are fitted with blocked chute detectors to prevent any potential material blockages, and thus facilitate material flow.

#### Physical Sampling for particle size

The physical sample from the secondary RTS will be further subjected to two sampling stages to achieve a manageable final sample size still maintaining the minimum sampling protocol requirements for ISO compliance.

The RTS physical sample discharge chute is fitted with a flopper gate. This flopper gate will send random sample increments, as selected from a random number generator algorithm in the PLC, to rejects. The number of physical samples received (not rejected) is a function of the hourly subplot's total production.

The secondary sub-increments reporting to the physical sample after the flopper gate are stored and accumulated in a 200L physical sample intermediate storage bin for 4 hours. From the 200L bin, the sample discharges onto the tertiary sample feeder and is fed to the tertiary rotating plate divider (RPD). The RPD is equipped with a 240mm cutter width and results in a sample division ratio of 11.2%. The tertiary RPD will subdivide the secondary physical sample increment to obtain a 4.13kg tertiary physical sample increment.

The tertiary sample from the rotating plate divider is stored in the cascade splitter weigh bin (600L) coupled with the cascade splitter vibratory feeder. The cascade splitter will further split the sample into 1.38kg per tertiary increment, to be accumulated in a 20 way by 30L canisters for ease of sample handling. A total of 496kg will be collected per 24 hours which exceeds the ISO minimum requirement of 210 kg (3 times 70kg for 2% precision).

The rejects from the rotating plate divider are directed to the rejects chute and flows to the power station's main product belts by gravity.

#### Chemical Sampling Stream.

The RTS chemical sample chute is fitted with an 80mm static grizzly screen plate and a blocked chute detector. The 80mm screen will prevent any particle larger than 80mm top size to proceed to the hammer mill impact crusher, thus minimizing blockages downstream. The oversize material will slide into the oversize tray and is retained until the end of the shift. It is important for the client to note the percentage of oversize material as a contractual penalty that affects their downstream pulverizing equipment. The mass proportion of oversize removed, compared to the linearly proportional total sample mass that passed through the grizzly as undersized, is calculated at the end of the shift. The oversize is manually crushed down in the laboratory and the proportionate oversize sample mass added to the plant generated composite sample mass. Composite chemical sample proportions (of over and undersized material) are maintained through the manual controlled laboratory procedure.

The undersize material is fed via the dedicated feeder belt to the hammer mill impact crusher. The crusher reduces the material size down to 95% passing -6mm in a single pass and discharges onto the chemical sample belt feeder designed to trickle feed the chemical sample RPD.

The sample from the chemical sample RPD is subdivided further by a quaternary turnstile divider (refer Figure 4) to produce 3 replicate composite samples to be stored in three 60L composite, lockable sample bins as per customer requirement: buyer, seller, and referee. A minimum of 4kg composite chemical sample is required (ISO 13909, 2016<sup>2</sup>) per replicate sample., hence, a minimum of 12 kg (3 x 4kg) is required. The 4kg of -6mm material marks the end of in

plant sample preparation. The samples are collected by operators at the end of the shift and taken to the lab for pulverization, preparation, and analysis. The rejects from the chemical RPD and the quaternary turnstile divider is automatically directed back to the power station's main plant conveyor through the rejects stream chute. The inlet and outlet of the hammer mill impact crusher, as well as the sample discharge chutes of the chemical RPD are fitted with blocked chute detectors.

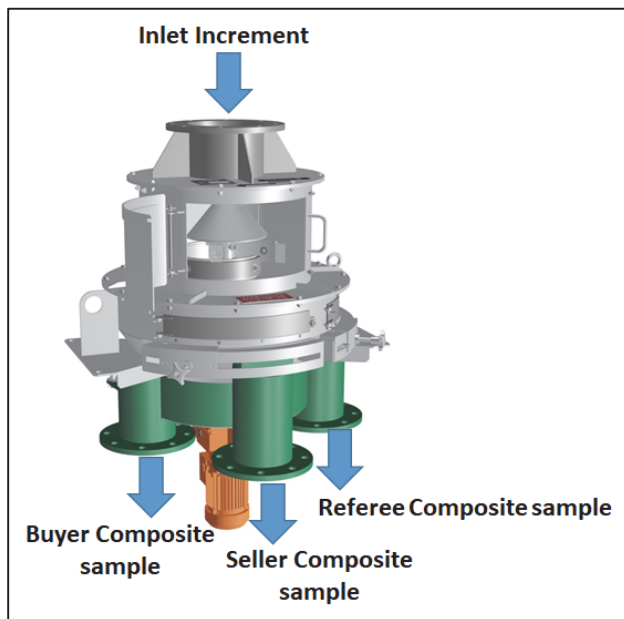

**Figure 4. Tripartite Composite Samples for Buyer, Seller and Referee**

#### Moisture Sampling Stream.

Moisture sample increments are isolated to the moisture sample bin or to the rejects chute using a random stratified PLC-controlled algorithm. Received samples are stored in a 90L collection bin (a maximum of 2 random secondary increments from the RTS to make up the 60kg minimum moisture sample required by the ISO 13909-2 standard). The moisture sample is isolated at first reasonable opportunity to prevent unnecessary moisture loss. Early extraction ensures reliable moisture preservation which would otherwise be lost to equipment internal surfaces if the moisture increments were extracted further downstream in the sampling plant. Despite 2-hourly collection recommendation, moisture samples are collected 8 hourly as per client requirements and resource availability. Excess sample increments will be fed to the rejects stream by the diverter to automatically return sample rejects.

#### Material handling.

The sampling plant is designed taking into consideration the flow of sample increments throughout the sampling plant. Interconnecting chute work design is not defined in ISO standard, however, Multotec's experience in the supply of coal sampling plants has established that 304 stainless interconnecting chutes with rounded 50mm radius corners and a minimum of 60-degree angles with 55 degree valley angles, is ideal for most coal types, surface moisture and size. Critical chute locations within the sampling plant are fitted with blocked chute detectors equipped with vibrating motors. If a blocked chute is detected, this will activate the respective vibratory motor to clear the blockage. It should be noted that available space sometimes creates challenges to achieve the above chute design characteristics, therefore, feed-

back loop type process is paramount between process designers, draughtsman, and site people to design the entire sampling station to be operator- and maintenance friendly.

## Conclusions

The design of the sampling system needs to follow specific guidelines as outlined in the various ISO standards taking into consideration available space, headroom, material handling, experience with similar type of sampling systems to achieve the required precision levels. Specific to this coal fired power station sampling plant, it was important to follow the ISO 13909 and client's requirements in terms of sampling frequency, lot period, material size to be delivered to the lab ( $P_{95}=6\text{mm}$ ), size analysis precision (2%) and 0.2% ash precision level for chemical analysis, to ensure that an ISO 13909 sampling plant is supplied. The sampling plant is expected to representatively sample the coal trade between power station and fuel supplier. As a result of its importance and the commercial value of coal passing daily, the power station, SEM and seller all provided inputs to the design and acceptance of the sampling plant

The available infrastructure created the necessity to design a custom primary cross-stream belt end sampler with articulated discharge joint to ensure that the sampler fits and operates in a 6m head room space. The minimum ISO 13909 requirements were exceeded by the design of the sampling plant which included minimum sub-increment cuts per preceding stage (more than 12 sub-cuts were achieved), minimum composite sample masses for chemical, PSD and moisture. Since the basis of the sampling plant was mass-based instead of time-based, this required that the primary increment collected by each primary sampler be constant irrespective of the instantaneous mass loading during increment collection. A VSD is incorporated into the design and operation of the primary sampler to ensure that the cutter speed of the sampler is automatically adjusted based on the instantaneous loading of the conveyor when the sampler takes a cut.

The preparation of the various increments was done via a four-stage sampling system consisting of a primary cross stream sampler, rotating tube splitter, rotating plat divider and turnstile divider sampling equipment, with the rejects produced from each sampling equipment returned back to the client's main production conveyors via 304 stainless steel interconnecting chute work. To minimize and eliminate any potential blockages, interconnecting chute work angles were 60 degrees or more.

## References

1. Steinhaus, R.C., and Minnitt, R.C.A. 2014. Mechanical Sampling - a Manufacturer's Perspective. *The Journal of The Southern African Institute of Mining and Metallurgy*, vol. 114, January 2014. pp 121-130.
2. Holmes, R.J. 2010. Sampling Mineral Commodities – the good, the bad and the ugly. *The Journal of The Southern African Institute of Mining and Metallurgy*, vol. 110, June 2010. pp 269-276.
3. Minnitt, R.C.A. 2007. Sampling: The impact on costs and decision making. *The Journal of The Southern African Institute of Mining and Metallurgy*, vol. 107, July 2007. pp 451-461.
4. International Organization for Standardization. (2016). Hard coal and coke—Mechanical sampling – Part 2: Coal – Sampling from moving streams (ISO/FDIS 13909-2:2016(E)).
5. International Organization for Standardization. (2016). Hard coal and coke—Mechanical sampling – Part 4: Coal – Preparation of test samples (ISO/FDIS 13909-4:2016(E)).



## The state of organized sampling work for minerals in China since WCSB9

Huachang Li<sup>a</sup>, Shufang Tang<sup>a</sup> and Lijun Kuai<sup>a</sup>

<sup>a</sup>BGRIMM MTC TECH Co., LTD, Beijing, China E-mail: [Li\\_hc@bgrimm.com](mailto:Li_hc@bgrimm.com)

**The state of organised sampling work for ore products in China since WCSB9 is introduced in this paper, including national standards, industry standards and group standards in China. In particular, the group standards organized by CSTM Material Sampling and Blending Technical Committee are introduced, meanwhile, the development of automatic sampling and sample preparation system, slurry on-line samplers and multiplexer dividers, on-line sampling and LIBS analysis technology integration system in China in recent years are introduced.**

**Key words: Chinese standards, sampling work, mineral, automatic sampling and sample preparation system, on-line sampling**

### Preface

In May 2019, WCSB arrived for Asia and China for the first time. The industry's top event shared the cutting-edge sampling and blending theory knowledge, covering mining, food, pharmaceutical, agriculture, biology, environmental protection and many other aspects. Participants learned valuable experiences and cases from internationally renowned experts and promoted academic and practical exchanges.

The actual demand and market space for sampling theory and technology in China is huge. The relevant sampling research in China has just started, which is far from meeting the needs of reality and lags far behind the research development and practical application of international advanced sampling theory. WCSB9 promoted the research of sampling theory and practice in various related fields in China.

In the past two years, China has made some achievements in the standardization of sampling and preparation, especially the group standards organized by CSTM Material Sampling and Blending Technical Committee, which is committed to the unification of sampling terms and supervision and management standards in the Chinese inspection market.

### Chinese standards for sampling and preparation of minerals since WCSB9

Table 1 lists the major standards for the sampling and preparation of minerals in China After 2019. The table mainly describes the sampling methods of precious metal concentrate, ferroalloy products, waste palladium carbon, zirconium and zirconium alloy, gold nugget, copper, lead anode mud, bulk flotation copper concentrate, etc.

**Table 1. Chinese standards for sampling & sampling preparation of minerals since WCSB9**

rank	Chinese standards
1	YS/T 1328-2019 Methods for sampling and sample preparation of precious metals concentrates
2	GB/T 13247-2019 Methods for sampling and testing the grain size of ferroalloys products
3	GB/T 39292-2020 Methods for sampling and sample preparation for analysis of palladium carbon wastes
4	YS/T 1466-2021 Methods of sampling and sample preparation for chemical composition analysis of zirconium and zirconium alloy
5	GB/T 13449-2021 Method for sampling and sample preparation of gold lump ores
6	YS/T 87-2021 Methods for sampling and sample preparation of copper anode mud and lead anode mud
7	YS/T 96-2021 The method for sampling and sample preparation for gold and silver contents assaying in the bulk flotation copper concentrates
8	HG/T 5965-2021 Waste printed circuit board—Sampling and sample preparation procedures

9	T/CGA 025—2021 Method of sampling and sample preparation for tailing of gold mine
10	T/CSTM XXXX-202X Sampling and sample preparation terms and definitions of minerals
11	T/CSTM XXXX-202X System for supervision and administration of sampling and sample preparation of mineral products
12	T/CSTM XXXX-202X Intelligent Robotic Preparation System of Solid mineral
13	YB/T 4849-2020 The technical specification of on-line automatic sampling, sample preparation, particle size analysis and the determination of tumbler strength for sintering ore

YS/T 1328-2019 'Methods for sampling and sample preparation of precious metals concentrates' specifies the procedures and methods for sampling, blending and moisture determination of precious metal concentrates. The quality fluctuations are divided into three types: large, medium and small,  $\geq 2.5\%$  is large,  $1.0\% \sim 2.5\%$  is medium,  $\leq 1.0\%$  is small, obtained the minimum number of sampling at the desired precision at 95% probability is given. The method conforms to the quality fluctuation of the goods and the obtained samples by this method are more representative, which is suitable for the sampling and preparation of precious metal concentrates transported by conveyor belts, trucks, bins, ships, piles, and container bags. The standard emphasizes that the sample meets the requirements of analysis particle size.

GB/T 13247-2019 'Methods for sampling and testing the grain size of ferroalloys products' is a revision of the old standard. The old standard was adopted by ISO 4551:1987 'Ferroalloys-Sampling and sieve analysis'. Deoxidation and alloying of molten steel are realized by adding ferroalloy. This process has been changed from manual or feeding car to automatic feeding tube. Due to the limitation of automatic feeding system, the particle size of ferroalloy is strictly controlled. The old national standard GB/T 13247-1991 didn't have specific testing procedures. Through the collection of relevant standard data, collection of large steel mills ferroalloy particle size sampling method, manganese thin ferroalloy particle size analysis test and sieving test, etc. The revised national standards mainly added "normative reference documents", "equipment and tools", "crushing" operation, particle size 10mm and the following test screening requirements, manual screening operation requirements, mechanical screening operation, inspection report, etc., and modified sampling shovel sampling operation requirements, screening results dissent treatment, etc. The revised standard refines the granularity detection procedure and makes it easier to operate.

GB/T 39292-2020 'Methods for sampling and sample preparation for analysis of palladium carbon wastes' stipulates the general procedures, general rules, sampling pretreatment, sampling, sample preparation, marking and storage requirements of sampling and sample preparation for palladium carbon wastes. In the process of transportation and sampling, it is difficult to obtain homogeneous and representative samples because there are moisture and organic volatilization, light specific gravity, large volume, mixed liquid and solid, integral or partial pulping of palladium carbon waste. This standard provides for the use of incineration before sampling, high temperature carbon removal can make the weight and volume greatly reduced to 1% of the original, at this time sampling becomes easy, and can be very good to obtain a uniform representative sample.

GB/T 13449-2021 'Method for sampling and sample preparation of gold lump ores' is a revision of the old standard. The relationship between quality fluctuation, maximum particle size and sample size is increased. The parallel sampling method of unloading truck in the material yard and the sampling method of bagged bullion ore are added. Sample size requirement changed from -150 mesh to 0.074mm. YS/T 87-2021 'Methods for sampling and sample preparation of copper anode mud and lead anode mud' is a revision of the old standard too. In recent years, anode mud as an important by-product of copper and lead smelting enterprises, its trade share in the market is increasing. Due to the characteristics of copper and lead electrolysis production process and the complex composition and high value of anode mud, the original YS/T 87-2009 sampling method can no longer meet the current demand of trade, especially the lack of sampling method of ton bag packaging anode mud, resulting in the inspection dispute between the supply and demand sides in the anode mud trade. Through the revised standard, the inspection batch, sampling tools and sampling methods of anode mud in different packaging forms were standardized, to play a guiding role in the internal and external delivery inspection of anode mud, and to control inspection risks and reduce trade disputes by improving the representativeness of samples. The stratified oblique insertion sampling method is added in the new standard.

YS/T 96-2021 'The method for sampling and sample preparation for gold and silver contents assaying in the bulk flotation copper concentrates'. The standard is applicable to sample preparation for analysis of associated gold (Au:1g/t ~ 30g/t) and silver (Ag:20g/t ~ 2000g/t) in bulk flotation copper concentrate. The copper concentrate with gold and silver content not in its range can follow this method. The determination precision  $\beta_M$ , sample preparation precision  $\beta_p$  and sampling precision  $\beta_s$  values were determined by precision test. The total precision  $\beta_{SPM}$  in the basic batch was finally determined by comprehensive test data and the safety and economy of sampling, which were modified according to international practice and GB 14260. The total precision of bulk flotation copper concentrate with gold grade of 1g/t ~ 15g/t is 1.6 and that with gold grade of  $\geq 15$ g/t~30g/t is 2.5. The total precision of silver grade in 20g/t~500g/t is 20, and that of silver grade in  $\geq 500$ g/t~2000g/t is 20~80.

'Sampling and sample preparation terms and definitions of minerals', 'System for supervision and administration of sampling and sample preparation of mineral products', 'Intelligent Robotic Preparation System of Solid mineral' are group standards organized by CSTM Material Sampling and Blending Technical Committee. These standards are still in the development stage and only have draft versions at present, which are expected to be approved in November 2022.

The purpose of the standard 'Sampling and sample preparation terms and definitions of minerals' is to unify the definition of terms, the name of each process and the specification of equipment involved in the process of mineral product sampling and preparation, standardize the technical indicators of the intelligent system currently used in the market, improve the operation consistency of sampling personnel, and improve the representativeness and uniformity of test samples. Standardize the English translation of terms, in line with international advanced standards, to facilitate the unification and communication of sampling and preparation in international trade.

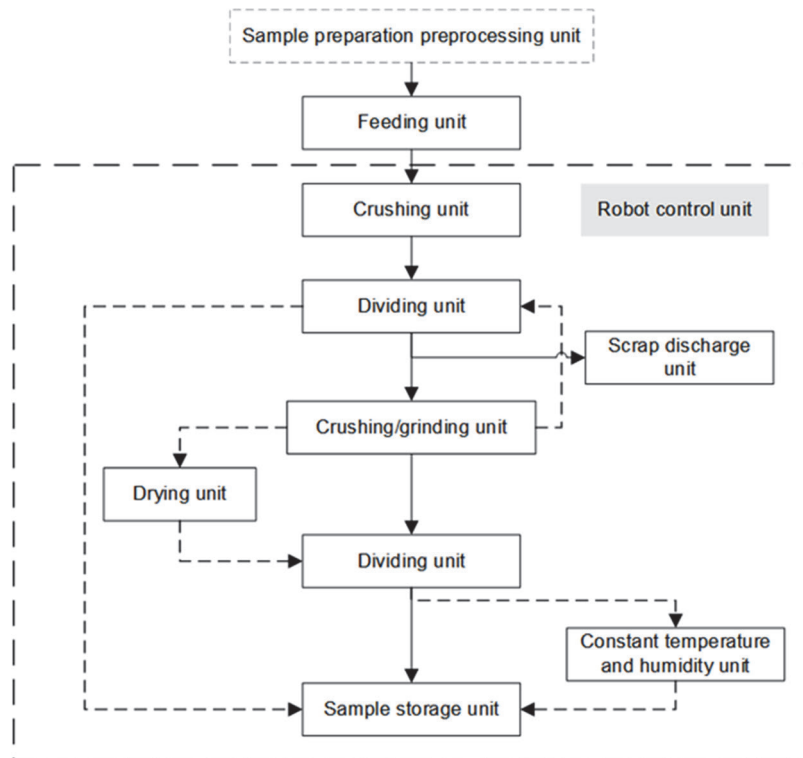

Figure 1. Schematic diagram of solid mineral robot sample preparation system

The purpose of the standard 'System for supervision and administration of sampling and sample preparation of mineral products' is to recommend the use of a sound sample sampling supervision system, to avoid the purposeful sampling and biased sampling. The standard mainly from the following eight aspects of standardization requirements, the formation of the whole sampling process supervision system:



1. Barcode encryption system
2. Automatic sampling system
3. Video surveillance system
4. Preparation before sampling
5. Sampling on site
6. Sample transfer
7. Sample preparation monitoring system
8. Personnel management

The standard 'Intelligent Robotic Preparation System of Solid mineral' has two parts. Part 1 is 'General Technical Specification'. This part specifies the system composition, use environment, workflow, marking, packaging, transportation, and storage requirements of solid mineral robot sample preparation system. Schematic diagram of solid mineral robot sample preparation system is outlined above in Figure 1. Part 2 is 'Performance Inspections'. This part specifies the terms and definitions, test items, test preparation, test methods and requirements, test period, test report and other requirements in performance test and acceptance of solid mineral robot sample preparation system. The main projects of performance test of solid mineral robot sample preparation system include:

1. Stand-alone test
2. Water adaptability test
3. Processing capacity test
4. Precision test of the whole machine
5. Bias test

The performance test shall be valid for two years and shall be conducted immediately in the following cases:

1. Design, production, or commissioning of a new system
2. When the system feeding, crushing, dividing, drying, pulverizing and other key components are replaced;
3. Higher requirements or doubts on sample preparation precision or bias;
4. When the variability of coal increases significantly.

## The Development of Automatic Sampling and Sample Preparation System

In recent years, the cargo volume of bulk ore products in China is on the rise, and the sampling and detection are heavier, so it is particularly important for the automatic sampling and preparation equipment and system of all kinds of minerals at the port. With the rapid development of mechanical automation and internet of things technologies, the functions of the automatic sampling and preparation equipment are more diversified, the technology are more standardized, and the operation more intelligent, which have been promoted in more and more ports, and the business environment at ports has been significantly.

### Sensor of iron ore mechanical sampling facility

With the development of intelligent technology, new sensing technology has been introduced in iron ore sampling facilities. Programmable controller (PLC) of iron ore mechanical sampling and sample preparation facilities, to issue action instructions to the equipment, it must get the status information and relevant measurement information of each component. This information is generally obtained through low-voltage electrical appliances and sensors installed in various parts of the sampling and sample preparation facilities. Commonly used sensors include weighing sensors, position sensors, moisture sensors, etc., which respectively undertake the position information and weighing information of the sampling and sample preparation facilities. In principle, the component equipment of the sampling and sample preparation facilities can be controlled separately, and each equipment is equipped with machine side control facilities, and the design is the machine side priority.

The sensor technology of sampling and sample preparation facilities has been used in iron concentrates grade sensing technology, quality fluctuation check prediction technology, microwave technology, isotope nuclear technology, video and image recognition technology, etc. The development of these intelligent technologies makes some processes of the facilities replace the original work that requires a lot of physical strength, improve the hardware sensing to the level of software sensing, and makes the iron ore mining sensing technology more stable and reliable, reduce the cost and improve the efficiency.

### The 4th generation of mobile intelligent sampling vehicle

The Port mobile intelligent sampling vehicle (3rd Generation) with automatic feeding function has solved the problem of sampling in any location and area. However, when it's working in the small space, the body cannot be moved well. This leads to a single product sampling point, which does not represent the product very well, and it has an impact on the results. The 4th generation of intelligent sampling vehicle is designed to solve this problem. The vehicle can collect samples at multiple points and operate in a narrow space, with the small sampling error, well representative, high efficiency, and saving manpower. The third and fourth generation sampling vehicles are respectively shown in Figure 2.



**Figure 2. The 3<sup>rd</sup> generation (left) and fourth (right) of mobile intelligent sampling vehicle**

The 4th generation of intelligent sampling vehicle mainly includes the feeding manipulator, lifting and feeding device, automatic blending device, conveying device, rotary division device, discarded sample output device and collector set on the vehicle body.

The feeding manipulator takes part of the bulk or powdery material as the sample material. The receiving hopper with the sample material rises from the bottom of the lifting and feeding device to the top of the device for unloading. The sample material received by the receiving hopper flows out of the outlet of the automatic blending device and is transported by the conveying device to the rotary division device with an up and down sampling trough. The discarded sample output device and the sample receiving conveyor are located in the lower position of the device. The sample discharged by the rotary division device is transported to the collector, and the sample material that is not sampled flows to the output of the discarded sample output device.

The 4th Generation Intelligent Sampling Vehicle adopts a 6-axis manipulator, with a shovel, grabber or spiral sampling head for sampling. Realizing the random determination of the number and location of sampling points, and automatically complete the processes of sampling, lifting, primary division, sample abandonment and secondary division. The samples are more representative without artificial errors.

### Manipulator sample preparation system

The manipulator automated sample preparation system is designed to solve the problems of large number of samples collected, low efficiency of manual collection alone, unstable sampling performance, etc.

The system comprises at least two sets of sample preparation units and a movable manipulator located between the two sets of sample preparation units, the sample making unit comprises a sequentially set of the first crusher, the first dividing machine, the second crusher, the second dividing machine, the dryer, the weighing device, the third dividing machine, the grinding machine, the bagging machine, the manipulator can be moved to the first crusher, the first dividing machine, the second crusher, the second dividing machine, dryer, weighing device, the third dividing machine or grinder position feeding or unloading.

The sample preparation system is mainly suitable for the preparation of a large number of samples, fully realizes the automation of material sampling, can randomly determine the number of sampling points and locations, automatically complete the sampling, sample preparation, crushing, dividing, sampling, residual material return, air transmission system, automatic storage cabinet and other whole process, without any human factors involved, the sampled products are strongly representative, can correctly reflect the authenticity of material quality, and have obvious advantages in safety, environmental protection, energy saving, high efficiency and other aspects.

Linear and Ring manipulator sample preparation system as shown in Figure 4 are suitable for processing a large number of samples of the preparation, It fully realizes the automation of material sampling and preparation

without any human factors. Up to 9 particle size levels can be measured simultaneously. The sieving and granulation level could adjust flexibility and good sample representation.

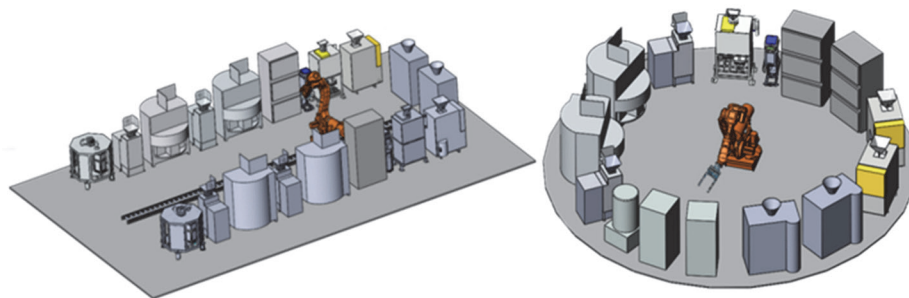
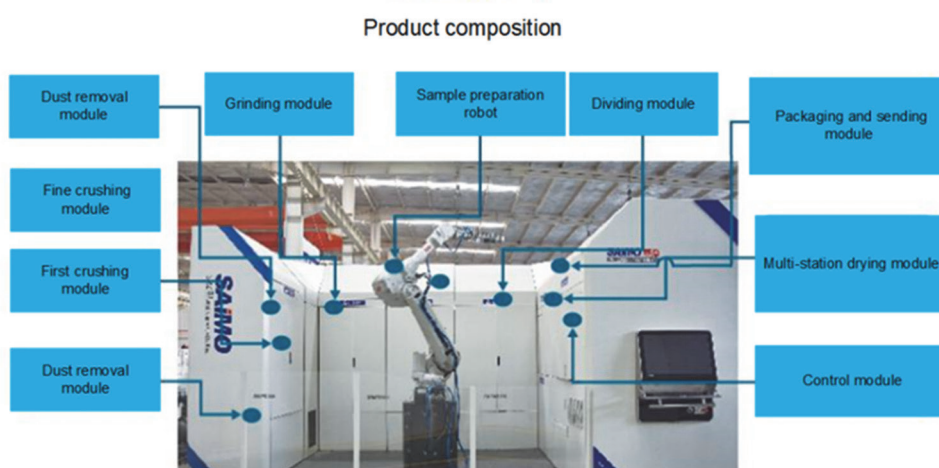

**Figure 4. Linear manipulator (left) and Ring manipulator (right)**

#### Automatic robot sample preparation system

The Figure 5 shows the automatic robot sample preparation system. Sample preparation scheme is flexible. The whole process of sample entry and exit can be weighed, sample preparation is transparent and visible, less residue, less error. The sample can be automatic packaged and transmission.

Automatic robot sample preparation system has built-in various sample preparation schemes such as sample preparation process, drying time, division ratio etc. Automatic and flexible adjustment according to the sample parameters, remote setting and the system automatically select the sampling scheme. The built-in mixing device can ensure the representativeness of the sample.



**Figure 5. Automatic Robot sample preparation system**

The open size and rotation speed of the divider are adjustable. Automatic calculation of division ratio and automatic adjustment according to the weight of the sample to ensure the constant quality of retained samples. The feed flow of the divider can be automatically adjusted and can be fed evenly. Before grinding, wash the grinder and the inlet and outlet sample line. Sample containers are cleaned automatically with a gas and cleaning device. The pipeline and sample preparation equipment are automatically cleaned by compressed air. Built-in full-moisture online analysis module can upload results automatically. The automatic robot sample preparation system can ensure the sample is representative enough and meet the precision requirements.

#### Application of automatic sample preparation system in bauxite industry

The automatic sample preparation system is applied in bauxite. The Process is shown in Figure 6. The user only needs to import the sample into the warehouse of the hoist and put the IC card circulating with the sample on the card reader of the upper industrial control machine for information leading to start the automatic sample preparation.

To meet the fast-paced sample preparation, the system is divided into 10 main units, such as primary crushing unit, secondary blending-division, crushing unit, drying unit, powder production unit, bottle conveying unit, sample and abandoned sample transmission unit, packaging writing card unit, electrical control unit, pneumatic control unit and dust removal unit. The single sample stays in different stages of crushing, dividing, each drying station and pulverizing for no more than 4 min, ensuring that the single sample preparation time is less than 6 min during continuous operation.

The automatic sample preparation system from the loading to crushing, dividing, drying, milling until bottling, code writing and other whole process to achieve automation. To prevent the loss of samples after sample preparation failure, a temporary storage mechanism is set up before the 3mm analytical samples and storage samples are prepared.

For the case of excessive water content, the pre-drying unit is used to replace the field drying, and the lost water is automatically included in the sample moisture data, which improves the efficiency of sample preparation.

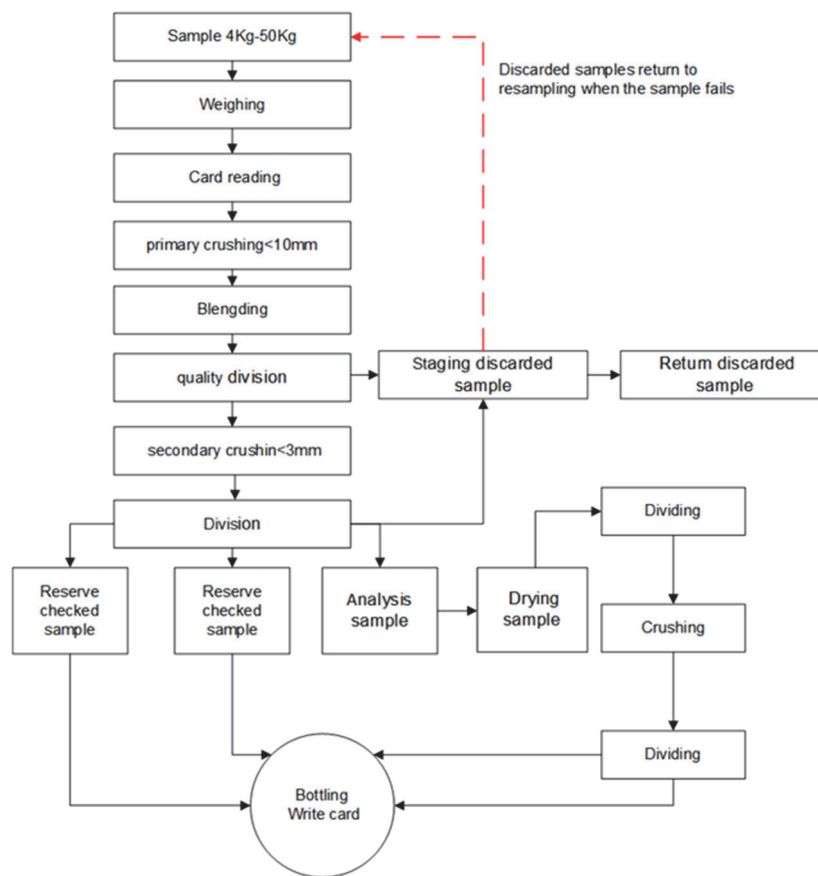

Figure 6. The process of sample preparation in the Bauxite industry

## The development of slurry on-line samplers and multiplexer dividers

### Pulslurry line sampler and multiple-channel divider

According to the difficult technology of the sampler and the multi-channel divider, a mobile knife-edge type sampler and a multiple-channel divider (Fig.7) were developed. Mobile knife-edge sampler is a device developed for the sampling of pressured or non-pressure (self-flowing) pipes in the flotation process of phosphate rock, providing samples for the grinding fineness and composition of the product in the flotation process.

The instrument is equipped with a sampling tube inside, and the cylinder-driven scraper scrapes up and down once, which is to make the sample intercepted by the sampling tube have a good representation. Due to the particles, corrosiveness and other characteristics of the slurry, the inner wall of the sampling tube is coated with a 5 mm thick wear-resistant ceramic sheet. The upper and lower parts of the sampler are lined with ultra-high polymer materials, which can ensure that the sampler can be wear-resistant, corrosion-resistant and long-

lasting. The sampling pipe can be automatically flushed at regular intervals to ensure that the sampling pipe is unobstructed.



**Figure 7. Mobile knife-edge sampler(left) and multiple-channel divider (right)**

The multiple-channel divider can realize the mutual switching between multiple slurry runners to achieve the purpose of measuring multiple runners simultaneously by an online analyzer, the entire slurry sample switching process is not used valves, so that the entire measurement process of the slurry sample flows smoothly and is convenient to observe the size of the flow, the slurry samples entering the buffer box are removed by slag, preventing the blockage of the online analyzer measurement window, according to the size of the slurry flow, the tuning fork switch position signal controls the cylinder to push the rubber spinal canal to supplement the buffer box. It can also achieve the effect of stirring the slurry in the buffer box, at the same time, special flushing water is added to ensure that the online analyzer measurement can operate normally.

At present, the sampler and multiple-channel divider developed by this topic have been applied to the 4.5 million tons/year phosphate ore of Yunnan Linhua phosphate concentrator for application demonstration. Figure 8 show in-field pictures of on-line sampler and multiple-channel divider of slurry. The user uses the test report showing that the sampling system continuously and respectively samples the raw ore, concentrate and tailings. The sampling process is stable and representative. It can provide a stable slurry flow for the slurry online LIBS analyzer. The sampling system can also be used in other flotation processes to provide test samples for on-line analytical instruments.



**Figure 8. On-line sampler and multiple-channel divider of slurry**

### Online sampling and LIBS analysis technology integration system

With the purpose of online monitoring of element components of phosphate ore flotation process, based on LIBS technology, combined with mobile knife-edge type samplers and multiple-channel dividers, it has become an on-line sampling and LIBS analysis technology integration system suitable for phosphate ore flotation process, realizing the rapid analysis of phosphorus, magnesium, iron, silicon and other elements in phosphate ore slurry.

Three knife-edge type samplers are installed at the appropriate position of the raw ore, concentrate and tailings pipelines for intercepting the mineral slurry for testing. The mineral slurry passes through the transportation pipeline to the multiple-channel divider and flows into the multiplex flow stabilization box. At this point, the LIBS analyzer receives a signal that the slurry is in place. The laser starts to stimulate the stable mine slurry column under the steady flow tank flow. After the slurry flow ends, the pump begins to work and automatically clean the sampler, pipeline and multiple-channel divider to ensure that there is no slurry residue in the flow path. The schematic diagram of online sampling and LIBS analysis technology integration system is shown in Figure 9.

The detected slurry and cleaning water return to the corresponding position, such as the original ore to the original tank, the concentrate to the concentrate pond, the tailings to the tailings pond, to avoid the waste of pulp, and the whole analysis and test process can form a closed loop.

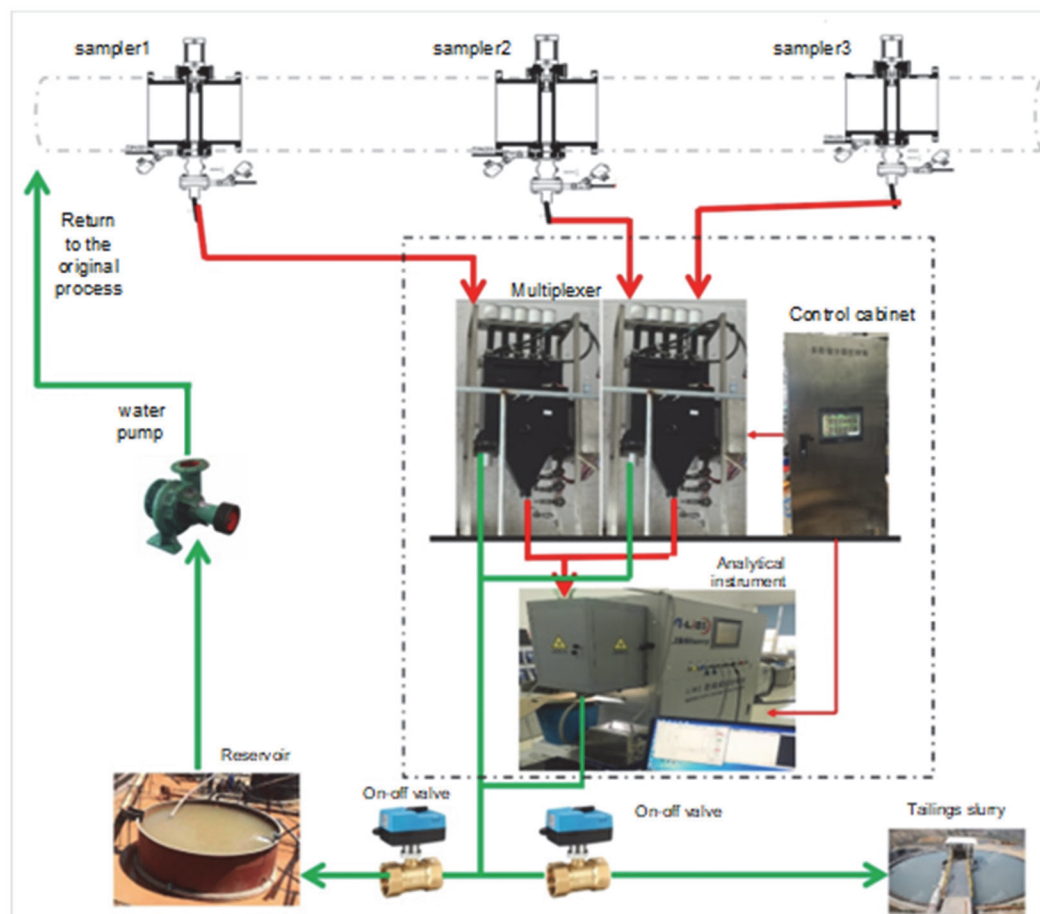

Figure 9. Online sampling and LIBS analysis technology integration system

### The development status and trend of sampling preparation system

#### Automatic sampling and sample preparation system

Guangxi Iron and Steel Group Co., Ltd. has invested and built a new set of automatic sampling and sample preparation system in the Fangchenggang iron and steel base terminal. The process flow chart of automatic sampling and sample preparation system is shown in Figure 10. The system is designed according to the national standards for iron ore and coal sampling and sample preparation. Large robotic hands simulate manual

operation for sample preparation of moisture content, particle-level distribution, physical properties, and sample preparation of chemical composition analysis.

The operating load capacity and process of the sampling and sample preparation system are fully compatible with the port loading and unloading main system. The system is composed of four parts: primary sampling, secondary sampling, robot automatic online sampling preparation unit and material return mechanism. The human error caused by manual sampling is avoided, and the representativeness of the sampling is guaranteed.

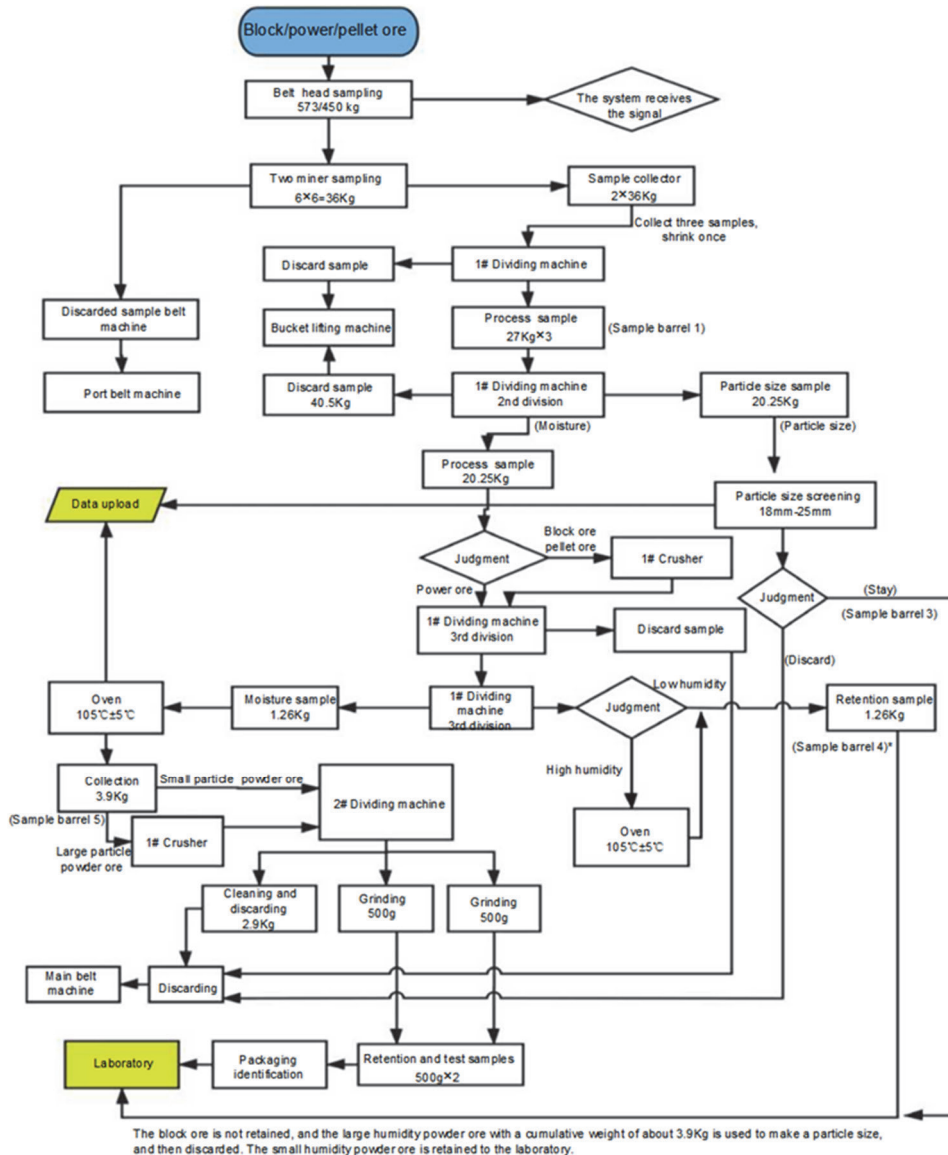

**Figure 10. Process flow chart of automatic sampling and sample preparation system**

### Application of mobile internet of things in the optimization of mineral product inspection and testing process

The internet of things is a huge network formed with the Internet by collecting any information that needs to be monitored, connected, or interactive through a variety of information sensing devices. Its purpose is to realize the connection between objects and things, things and people, all objects and the network, to facilitate the identification, management and control.

The whole process of minerals sampling and sample preparation uses mobile internet of things technology to comprehensively perceive, safe transmission and intelligent processing to optimize the sampling system and process and solve the problems in a series of mineral inspection and testing process. The developed mobile internet of things technology includes the computer operating system, mobile terminal APP and WeChat public

account program. The three methods are simultaneously compatible and optimize the existing inspection workflow of minerals. Each link is better seamless docking, including the information transmission process with customers, more transparent, timely, and can improve the work efficiency of inspection. At the same time, in terms of quality supervision, the whole process of minerals inspection is traced, which improves the quality of inspection.

At present, there is no blind number editing, and equipment traceability only traces the equipment model and equipment status that cannot automatically collect data, and not studies the data collection of automatic collection and detection results. Meanwhile, the security and confidentiality agreements involved in the internet of things process are not discussed, which needs to be further improved later.

## References

- Yu Lanlan, Li Yulu, Ying Haisong, Application and configuration of sensors [J]. *Modern Mining*, 2022,38 (01): 179-184.
- Zuo Zhaoying, Xu Guangcheng, Zhang Jun. Experimental Research on the Performance of Mobile Intelligent Sampling Equipment in Rizhao Port [J]. *Quality and Certification*, 2019 (01): 80-82.
- Wang Yixian, Xu Guangcheng, Zhang Jun, A mobile sampling vehicle and Sampling method [P]. Shandong Province: CN109612778A, 2019-04-12.
- Yu Shuangmin, Wang Yixian, Xu Guangcheng, A sample making car with automatic feeding function [P]. Shandong Province: CN211576653U, 2020-09-25.
- Wang Yixian, Xu Guangcheng, Yu Shuangmin, An intelligent mobile online sample pickup car [P]. Shandong Province: CN210802956U, 2020-06-19.
- Chen Yongxin, Zhou Shan, Wu Guoqing, He Longyang Liang. Process design of automatic sample preparation system of Guangproducts [J]. *China Port Science and Technology*, 2021 (03): 50-54.
- Xu Yushan, Bai Xintian, Zhou Ping, Application of Fully Automatic Sampling System in Bauxite Industry [J]. *Coal quality technology*, 2020,35 (06): 80-83.
- Zheng Fuqiang, Ma Yurong, Duan Shengjian. A fully automated sample preparation system [P]. Shandong Province: CN213544168U, 2021-06-25.
- Wang Shuai, Zhou Yumeng, Chen Shengpeng. A robot comprehensive sample preparation system and method in metallurgical industry [P]. Shandong Province: CN113008595A, 2021-06-22.
- Zhu Mingwei. The Application of mobile Internet of Things in the optimization of mineral product inspection and testing process [J]. *Quality and Certification*, 2020 (10): 77-79.

## Acknowledgements

Financial support from the 14<sup>th</sup> five-year plan national key research and development projects in China, 'Research and application of strategic mineral metallurgy analysis and testing technology and standard system' (2021YFC2903100). The authors thank organizations that formulate relevant national standards, industry standards and group standards, in especial the group of CSTM Material Sampling and Blending Technical Committee.





## Sampling for resource evaluation and grade control in an underground gold operation: a case of compromise

Simon C. Dominy<sup>a,b,c</sup>, Hylke J. Glass<sup>d</sup> and Saranchimeg Purevgerel<sup>e</sup>

<sup>a</sup>OCX Gold Group, Vancouver, BC, Canada.

<sup>b</sup>Camborne School of Mines, University of Exeter, Cornwall TR10 9FE, UK. E-mail: s.dominy@e3geomet.com

<sup>c</sup>Western Australian School of Mines, Curtin University, Perth WA 6102, Australia.

<sup>d</sup>Camborne School of Mines, University of Exeter, Cornwall TR10 9FE, UK. E-mail: h.j.glass@exeter.ac.uk

<sup>e</sup>MSA Global LLC, Bayanzurkh District, Ulaanbaatar 13370, Mongolia. E-mail: p.saranchimeg@msaglobal.net

The foundation of any resource evaluation and/or grade control programme is the collection of high-quality samples within a geological context. The requirement for quality samples has long been recognised, where they must be representative and fit-for-purpose. Correct application of the Theory of Sampling reduces sampling errors across the collection to assay process. This contribution presents a case study where small-sample based assays understate grade in geometrically simple, coarse gold-dominated veins. Drilling with whole core sampling and assaying is applied to estimate Inferred Mineral Resources that are accepted to understate grade. Dominant gold particle clustering drives the application of bulk sampling. Development drives are sampled as bulk composites and processed via an on-site plant. Upper and lower development drive grades are assigned to stope blocks and reported in the Indicated Mineral Resource category. The case study illustrates the challenges and potential solutions to achieve representative sampling. Solutions ranging from individual bulk samples processed through a plant, to bulk composites and whole-core sampling and screen fire assaying are discussed. These approaches account for the nature of the mineralisation, where extreme gold particle-clustering effects render the analysis of small samples problematic.

### Introduction

#### Sampling for Resource Evaluation and Grade Control

Underground mine evaluation and grade control aims to define tonnes and grade for project feasibility and production through the definition of ore and waste. The role of samples relates to informing resource/reserve block models; development ore/waste decisions; investigation of ore limits; identification of grade trends and/or continuity along development or stopes; and local/grade control estimation. Where samples feed into ore/waste decisions, the risks of potential misclassification and its economic impacts must be considered.<sup>1–3</sup> Many small- to medium-sized and some large mine operations rely on face samples and/or diamond core drilling for resource evaluation and/or grade control. These may be used to update a resource/reserve model that is publicly reported. This contribution presents a case study which emphasises ore characterisation, Theory of Sampling (TOS) application, component error analysis and an open mind.

#### Theory of Sampling

Sampling is a critical component throughout the mine value chain.<sup>1–11</sup> Without being able to analyse all material in advance, sampling of both in-situ and broken material serves to inform geological (resource and grade control), geoenvironmental and geometallurgical based mine planning and decision-making.<sup>1,3–7</sup> Sampling errors can generate both monetary and intangible losses.<sup>3,5–11</sup>

Representative samples are needed to effectively evaluate the style of mineralisation in question.<sup>1–7</sup> This can be particularly challenging in deposits with coarse gold (>100 µm particles dominate), where large field samples and special preparation-assay protocols may be needed.<sup>1–16</sup> Unrepresentative samples will not describe the true in-situ gold grade distribution and the overall result leads to a lower (undervalued) deposit mean grade. This is attributed to small samples having a high probability of missing influential coarse gold particles and reporting at the lower end of the grade distribution. As a result, there will be overestimation of block grades below the economic cut-off value,

that is, blocks which report as waste. Any fine-gold (<100 µm) background population is likely to be represented relatively well by small samples.<sup>12–14</sup> At the other extreme, samples may report as “false” high grades when they occasionally contain coarse gold particles. For example, 1 m of half HQ core (c. 4 kg based on 63.5 mm diameter core) will yield a grade of 40 g/t Au and 295 g/t Au if it contains a single 2.5 mm or 5 mm gold particle respectively. The presence of rare coarse gold particles in small samples may positively bias the deposit mean grade.

Quality assurance/quality control (QAQC) is critical to maintain data integrity through documented procedures, sample security and monitoring of precision, accuracy and contamination.<sup>17–20</sup> The ultimate test of any grade control programme comes through reconciliation of actual mine performance versus that predicted by grade control samples.<sup>20</sup>

The TOS aims to provide answers to two questions: *how should a sample be selected* and *how much material should be taken?* It defines a series of sampling errors which, if not minimised, lead to error and uncertainty in the final assay value.<sup>3,7–11</sup> TOS attempts to break down this error into a series of contributions from sample collection through to assaying (e.g., the sampling value chain; Table 1).

**Table 1. Sampling value chain from programme planning to assaying.**

Stage	Planning	Collection	Transport	Laboratory Preparation	Assaying
	1	2	3	4	5
Activity	Scope Develop Execute	Observe Collect Bag and tag QAQC Integrity/security Chain of custody	Integrity/security Chain of custody	Equipment operation Equipment clean QAQC Integrity/security	Equipment operation Equipment clean QAQC Integrity/security
Sampling errors		GNE, FSE, GSE DE, EE, WE	PE	FSE, GSE DE, EE, WE, PE	PE AE
Dominant effect on results		Precision Bias	Bias	Precision (if splitting) Bias	Bias

GNE: geological nugget effect; FSE: fundamental sampling error; GSE: grouping and segregation error; DE: delimitation error; EE: extraction error; PE: preparation error; WE: weighting error; AE: analytical error.

The heterogeneity of a given variable (e.g. grade) can be quantified through the nugget effect and has a direct link to TOS.<sup>3,10,14,21</sup> The nugget effect is a quantitative geostatistical term describing the inherent variability between samples at very small separation distances. The nugget effect has a wider remit than just differences between contiguous samples and its magnitude relates to the small-scale geological variation and sample measurement error.<sup>3,10,14,21</sup>

The geological component of the nugget effect expresses short-range data variability, which is particularly significant when samples are small, and protocols not optimised. The sampling component of the nugget effect expresses errors induced by inadequate sample mass, poor sample collection and preparation methods and poor analytical procedures. Throughout the mine value chain, sampling protocols should be optimised to reduce the sampling nugget effect which, in turn, reduces the total nugget effect, data skewness and the number of extreme data values.<sup>3,10,14–16,21</sup> In many cases, coarse gold-bearing deposits display a nugget effect of >50%.<sup>14,21</sup>

## Case Study: San Christina Mine

### Introduction

The San Christina mine is in South America and is privately owned and operated. During the period 2005–2012, the mine underwent a period of evaluation and subsequent mining. The programme yielded 75,840 t of ore at a reconciled head grade of 23.2 g/t Au for 42,290 oz Au recovered. Reconciliation during this period displayed strong variability, with some estimates under-calling grade by 75% based on diamond drilling alone. It was known that the mineralisation was dominated by coarse gold and that a significant nugget effect existed. As part of the mine re-evaluation, commencing in February 2018, a series of characterisation tests were undertaken to investigate gold particle sizing and grade variability. An Inferred Mineral Resource of 55,000 t at 9.5 g/t Au and an Indicated Mineral Resource of 16,500 t at 25.7 g/t Au were declared in late 2018 in accordance with the 2012 JORC Code.<sup>22</sup> Mining recommenced in February 2019 and continues to the present time (June 2022). The operation targets c. 40,000 t per annum based on an Indicated Mineral Resource of 75,000 t at 25.8 g/t Au and Inferred Mineral Resource of

225,000 t at 12 g/t Au reported in accordance with the JORC Code 2012. Based on the Indicated Mineral Resource, a Probable Ore Reserve of 65,000 t at 22 g/t Au was declared in March 2022. The combined resource/reserve base indicates that the project is likely to have an on-going life of 5-6 years, subject to additional development to uprate Inferred to Indicated Mineral Resources. Exploration potential exists to extend production beyond 5-6 years.

### Geology and Mineralisation

The sub-vertical vein system is hosted in a series of volcanic rocks. The veins comprise massive, brecciated to laminated quartz, with up to 5-20% pyrite, galena and sphalerite in the ore shoots. Individual vein widths vary from 0.5–1.5 m, with an average of 1.25 m. Outside of the ore shoots, the vein may reduce to a few cm or fault gouge. Locally the main Veta (vein) Christina (VC) splits, with splays emanating into short-lived (<25 m) to more continuous (up to 150 m) structures. The VC can be traced for 1,700 m along strike and for 400 m down-dip (confirmed by four deep drillholes).

The dominant fault movement associated with the veins is strike-slip, reflected by the sub-vertical to vertical orientation of the ore shoots. As well as the VC, four other vein systems have been identified where historical workings confirm gold mineralisation. The additional reefs contain an Exploration Target of 250,000–500,000 t with a grade range of 15–25 g/t Au. These reefs display similar characteristics to the VC, as observed in limited underground development, drill intersection and surface exposure.

Economic grades are located within the steeply plunging ore shoots that are traceable for 50–120 m along strike and >250 m down-plunge. All vein structures contain low-grades up to 2 g/t Au, with the ore shoots historically containing recoverable grades of between 15–30 g/t Au. The wallrocks contain minimal gold grades (<1 g/t Au, generally 0.25 g/t Au), except where stringer veins are present emanating from the main vein.

Two mineralisation stages are identified, an early sulphide-poor phase and a later sulphide-rich phase related to fault reactivation. Both phases contain coarse gold, though the earlier sulphide-poor phase generally contains more coarse and clustered gold. The two phases generally occur together, so the ROM feed bears both.

The veins that make up the ore shoots are generally continuous, though grades are variable and discontinuous low-grade zones can be present. Individual ore shoots globally represent between 45,000–150,000 t of mineralisation. Criteria for the recognition of an ore shoot, other than gold grade relate to: (1) well-developed laminated vein with thickness greater than 0.5 m; (2) the presence of pyrite-galena-sphalerite and locally visible gold as isolated particles or clusters; and (3) moderate to strong wallrock silicification. Low grade zones (<6 g/t Au) within the shoots generally lack laminations (or are poorly developed), sulphides and visible gold.

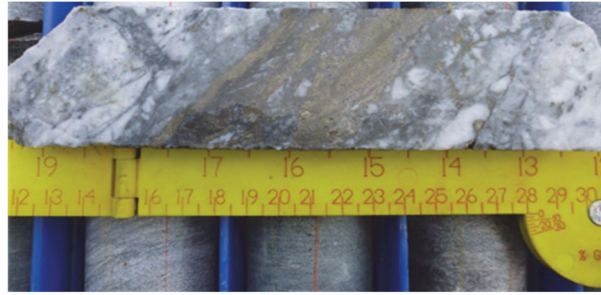

**Figure 1. Length of strongly sulphide (late phase) mineralised core yielding a grade of 108 g/t Au over 0.2 m, typical of the VC. The other side of the core contained visible gold.**

## 2018 Re-evaluation Programme

### *Heterogeneity Testwork*

Two 50 (1.5 kg) single piece tests were undertaken on VC mineralisation.<sup>23,24</sup> The material sampled was medium to ROM grade ore (15–25 g/t Au). The individual fragments collected were quartz dominated to reflect the nature of the reef (>90% quartz). The two tests yielded K values of 250 and 990 g/cm<sup>1.5</sup> respectively. Back-calculated  $d_{95Au}$  values were 75  $\mu\text{m}$  and 500  $\mu\text{m}$  respectively.

The tests show the potential precision issues with heterogeneity tests. Field observation indicates discrete gold clusters and visible gold are present. Gravity processing of ore verified the presence of coarse gold in ROM mineralisation up to 1.5 mm. The company concluded that a bulk sampling programme was required to characterise the mineralisation properly.<sup>1,4,5,14–16</sup>

### *Gold Particle Size and Liberation Diameter: Characterisation via Bulk Sampling*

A characterisation programme was undertaken based on a series of bulk samples collected on the accessible 2 level (VC2). Bulk samples were taken from the #2 shoot backs which extended for 65 m along strike. Samples were defined across a range of grades from low to high grade (Table 2). They were not collected consecutively but placed where required to achieve the desired grade. Bulk samples contained both early and late phases of mineralisation.

After detailed geological mapping and saw-cut channel sampling of the drive backs, seven locations were defined. At each location an approx. 1.5 m to 2 m long (strike) by 1.5 m deep (up-dip) by 1.5 m (target stope width) wide cut was mined into the level back to yield approx. 10 t to 13 t of sample. In the bulk sample area the vein width was between 1.1–1.5 m. Bulk samples were sent to an independent test facility in North America, where the material was stage processed through a pilot plant to liberate gold over a series of crush-grind concentration steps.<sup>25</sup> The gold liberated from each stage was sized and assayed to provide an indication of gold particle size distribution (Table 2 and Figure 2).

**Table 2. Summary of gold particle size distribution by mass across different grades based on eight bulk samples from VC2 #2 shoot.**

Grade (g/t Au)	+100 $\mu\text{m}$	+500 $\mu\text{m}$	+1000 $\mu\text{m}$	$d_{95Au}$ ( $\mu\text{m}$ )	$d_{maxAu}$ ( $\mu\text{m}$ )
0.5	3	0	0	95	200
2	53	0	0	300	400
<sup>1</sup> 6F	54	7	0	500	700
<sup>2</sup> 6C	66	21	5	1,000	1,500
9	65	16	6	1,200	1,600
13	67	22	8	1,900	2,100
24 (ROM)	70	26	9	2,000	2,500
39	69	26	10	2,250	2,500

<sup>1</sup> Fine-gold dominated; <sup>2</sup> Coarse-gold dominated.

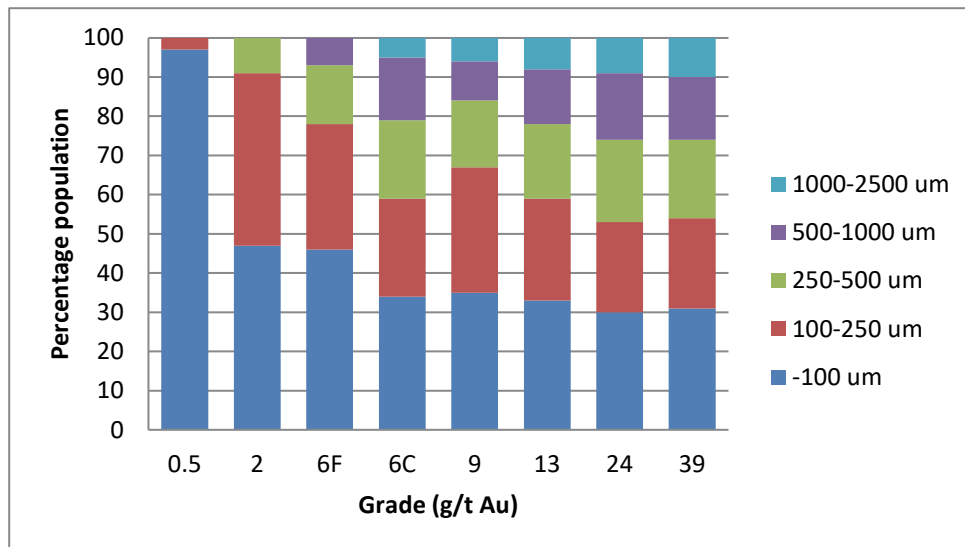

**Figure 2. Gold particle size distribution by mass across different grades from the VC2 #2 shoot. Columns represent percent of gold particle size population within the given size range. Refer to Table 2 for summary input data. um = microns.**

There is consistency of the sub-100  $\mu\text{m}$  to 500  $\mu\text{m}$  fractions with increasing grade and a relatively small increase in the >500  $\mu\text{m}$  fractions. There is a distinct variation in population at 6–9 g/t Au, where in some cases a finer gold population dominates (Table 2 and Figure 2; refer 6F) but in others a coarser population exists (Table 2 and Figure 2; refer 6C). These indicate a potentially more disseminated finer gold background population that may be easier to sample.

#### *Gold Particle Clustering*

Core logging and face mapping (principally VC2 and 3, #2 and #3 shoots) reveal that gold particle clustering becomes locally material throughout the VC ore shoots. Clustering can have a marked effect on sampling requirements.<sup>3,12,13</sup> These grade hotspots relate to 1–3  $\text{cm}^3$  of clustered >200  $\mu\text{m}$  gold particles, which provide gold-only composites of <0.25 to 1  $\text{cm}^3$  (Figure 3).<sup>12</sup> Individual cluster composites, assuming spheres, yield a mass of between 0.15 g to 9.5 g. These can be easily missed by small channel samples (13.5 kg/m) and core samples (4.9 kg/m).



Figure 3. Coarse gold cluster in sulphide-poor (Early phase) mineralisation from VC drill core. Width of cluster on core surface c. 20 mm (red circle).

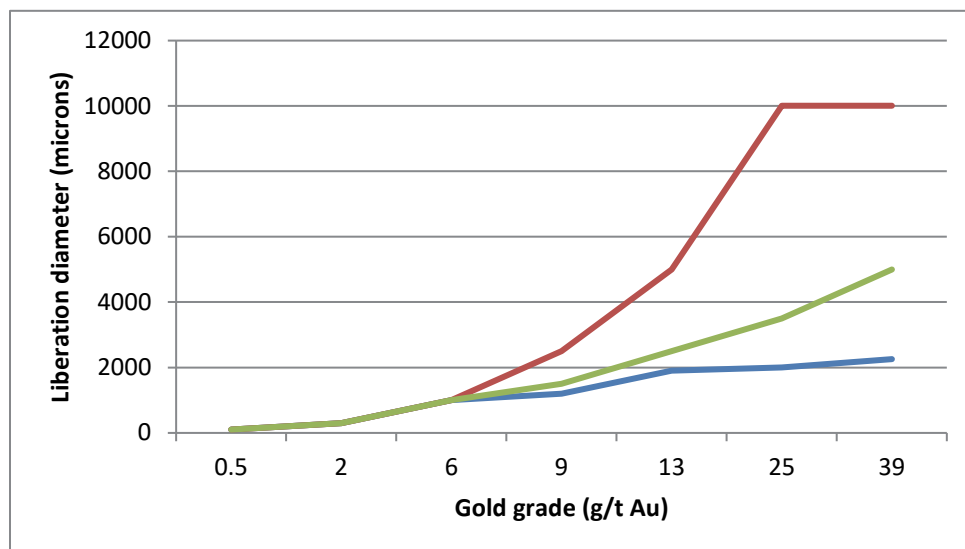

Figure 4. Inferred relationship between single particle  $d_{95Au}$  and effect of  $d_{Auclus}$  with grade in the VC. Red line maximum clustering effect; Green line minimum clustering effect; Blue line non-clustered ( $d_{95Au}$ ).

Gold particle clustering becomes locally material particularly at grades above 6 g/t Au (Figure 4). It is difficult to assess the true number of clusters in any tonne of ore. During the initial and later bulk sampling and trial mining programmes, all possible vein exposures were reviewed to identify clusters. For 25 g/t Au ROM ore, it was concluded that between 40–80% of the gold was in 1–5 clusters with an individual cluster composite mass of 4.0–9.5 g. Lower grade ore of 8–12 g/t Au was likely to contain between 20–50% of the gold in 5–20 clusters with an individual cluster composite mass of 0.15–2.0 g.

#### Theoretical Sample Mass

A theoretical field sample mass can be estimated using Poisson statistics to achieve a given precision ( $\pm 15\%$  at 90% reliability).<sup>25</sup> The range of mass values for BCOG and run of mine mineralisation is given in Table 3. The major driver for large sample mass at San Christina is the gold particle clustering effect.

**Table 3. Range of theoretical sample mass values for the VC across different grades.**

Grade (g/t Au)	$d_{95Au}$ ( $\mu\text{m}$ )/ [ $d_{Auclust}$ ( $\mu\text{m}$ )]	Clustering Effect	Optimum Mass
0.5	95	None	5 kg
2	300	None	10 kg
6 (BCOG)	500	None	30 kg
	1,000		165 kg
9	1,200	Potentially	175 kg
	[2,500]		1.5 t
13	1,900	High	5 t
	[5,000]		85 t
24 (ROM)	2,000	Very high	0.5 t
	[10,000]		35 t
39	2,250	Very high	270 kg
	[10,000]		24 t

### Sampling Protocol Development

Channel samples were cut using a diamond saw to produce a near uniform 10 cm wide by 5 cm deep channel to yield around 13.5 kg/m.<sup>2</sup> Two 5 cm saw cuts, 10 cm apart were cut, and a hammer and chisel used to break the intervening block of rock out of the channel. Samples were collected across the vein as 0.4–0.5 m lengths (5.4–6.7 kg/m) from the reef hanging- to foot-wall.

Samples were weighed and compared to their expected mass, which was 6.75 kg for the dominant 0.5 m samples. Around 75% ( $N = 206$ ) were within  $\pm 15\%$  of the target mass (e.g.  $\pm 1$  kg: 5.75–7.75 kg) based on 275 samples. Overall this was a good result, given the inherent challenges of collecting channel samples.<sup>2</sup> Mass variability related to the interrelationship between DE and EE, where the saw-cut depth could vary depending upon face profile. The extracted material depended on effort to remove the delimited sample and loss through fines and fly-rock.

Due to the presence of coarse gold, screen fire assay (SFA) was considered the most applicable technique. All channel samples were bagged and secured on-site and transported to an independent laboratory. Samples were dried and crushed to  $P_{90} -3$  mm, one-third was split by rotary sample divider (RSD) and pulverised to  $P_{95} -75$   $\mu\text{m}$  and then split for two to three SFA1000.

### Diamond Drilling Programme

During 2002–2003, a 49-hole surface diamond-drilling programme on the VC assessed the predicted ore shoot from surface to a depth of 250 m. The NQ (4.9 kg/m) holes were on an approx. 10–20 m by 10–20 m grid. Samples were collected across the vein as 0.4–0.5 m lengths (1.9–2.4 kg/m) from the reef hanging- to foot-wall. A 0.4 m sample was taken into both the hanging- and foot-walls for assay. After logging and photography, cores were cut in half and one half sent to an external laboratory. The samples were dried and crushed to  $P_{90} -3$  mm and pulverised to  $P_{95} -75$   $\mu\text{m}$  and riffle split into two halves, and both sent for SFA.

### Duplicate Pair Analysis—Channel and Core Samples

Duplicate pair analyses were undertaken for channel and core samples (Tables 4 and 5). The channel samples (79%) show a smaller sampling error component compared to the core (93%), probably relating to a larger mass (e.g. 4.9 kg/m versus 13.5 kg/m). Both values are relatively high and reflect a high geological nugget effect. The relatively high preparation error of the channel samples (32%) indicates the presence of coarse-gold at the split stage. The analytical error components for both channel and core samples are slightly higher than expected, reflecting the presence of residual coarse gold in the pulps. Overall the results show that channel samples are of better quality than core, though both error values are high.



**Table 4. Face channel sample duplicate pair analysis.**

Sample Type/Error (Preparation Route)	Sampling (%)	Preparation (%)	Analytical (%)	Total (%)
	Duplicate face	-3 mm split	-75 µm split	-
Face channel	79	32	18	87
Number of pairs	75	150	150	-

**Table 5. Core sample duplicate pair analysis.**

Sample Type/Error (Preparation Route)	Sampling (%)	Preparation (%)	Analytical (%)	Total (%)
	Half drill core	No split	-75 µm split	-
Diamond drill core	93	-	21	95
Number of pairs	100	-	200	-

## Bulk Sample Trials

### *Bulk Sample Strategy*

The high variability of channel and drill samples lead the project team to consider the use of bulk sampling to overcome the nugget effect.<sup>14,16,26,27</sup> During underground development, a programme of bulk sampling was undertaken. Bulk samples comprised three types: (1) drive round of 25–30 t; (2) raise development of 10–15 t; and (3) drive back cut of 15–20 t. All development faces were saw-cut channel sampled and mapped to guide the bulk sampling process. Individual rounds were transported to surface and isolated prior to processing.

### *Bulk Sample Processing*

It was considered optimal that each bulk sample be processed in its entirety through an on-site plant. This was driven by the availability of a pilot plant, albeit requiring renovation and upgrading, and the wish to reduce sampling error (e.g. avoid splitting and complicated procedures on large samples). Each bulk sample lot was batch milled through a gravity pilot plant that was able to process up to 5 t per hour. The plant was used for both bulk samples and initial production batches. Ore was passed through jaw and gyratory crushers prior to being fed into a 20 t capacity fine (–1.5 cm) ore bin. This bin was attached to four strain gauges to provide a weight determination. The fine ore bin fed into a ball mill, yielding a  $P_{90}$  –125 µm. The ball mill was fitted with a large access panel to allow cleaning and a bunded wash area immediately below to allow access and containment for washings. Washings were collected, tabled and assayed.

A simple gold trap was located at the outflow of the ball mill, which typically collected 10–25% of the gold in a sample (usually particles >0.5 mm in size). This trap was cleaned out after every sample. The feed then passed through a 0.5 mm screen, with the undersize passing to a 250 mm Knelson concentrator. The oversize recirculated to the ball mill. The Knelson concentrate was passed over a shaking table.

The mill circuit was flushed out after every sample with 2 t of waste rock and stripped/cleaned after every 4th sample (e.g. 120 t). Gold recovered during stripping was proportionally re-combined with the previous bulk samples based on their percentage gold yield. This was found to be the best way in which to deal with recovered gold in-circuit, as the higher the grade of ore processed the greater the problem. Between 5–10% of the batch gold yield was usually recovered from the ball mill. Minimal gold was recovered from elsewhere.

All concentrates were weighed, combined and tabled, prior to size by assay to extinction. Tails from the Knelson unit were sampled (1 kg) every 10 minutes via an automated Vezin splitter. Every hour, the composite tails samples (6x 1 kg) were removed for drying and on-site pulverisation to  $P_{80}$  –100 µm and then RSD split down to 2 kg. The series of hourly splits were submitted to an external laboratory for SFA2000. A 30 t primary bulk sample yields 36 kg of tails sample, with 6x 2 kg (12 kg) samples assayed. Reconciliation of mill gold yield and tails assays showed a recovery of >60% for grades >5 g/t Au and up to 85% for grades >15 g/t Au.

### *Bulk Sampling of 2 Level Veta Christina Reef*

Bulk sampling was undertaken along the VC2 #3 shoot drive. Sixty-five metres of 2.5 m by 2.8 m was driven along the reef, which varied in width from 1 m to 1.5 m. Based on bulk sample grade and geological features, the ore

shoot zone was represented by 43 m of strike, comprising 24 bulk samples. Each round was blasted and mucked carefully to ensure collection of all broken material (reduction of DE and EE). All bulk samples were processed through the pilot plant. All faces were channel sampled and mapped. Table 6 shows a comparison of sample types along the VC2 drive.

The bulk and channel samples grades were back-calculated to a 1.5 m mining width. The lowest variability is displayed by the bulk samples, with an RSV of 73% and nugget effect of 48%. In contrast, the smaller channel samples show a high RSV of 306% and an extreme nugget effect. The grab samples were diluted with material outside of the minimum mining width, showing a high RSV and mean grade, despite the dilution. The challenges of fines bias during grab sample collection (e.g. high DE and EE together with GSE) are well-known.<sup>2,3</sup>

**Table 6. Comparison of samples along the VC2 #3 shoot drive.**

Sample Type	Bulk	Grab	Channel
Sample mass/Total mass	30 t 835 t	5× 5kg (25 kg) 1 t	13.5 kg/m 472 kg
No. of samples	24	120	24
<sup>1</sup> Mean grade (g/t Au)	27.3	38.4	14.7
Min. grade (g/t Au)	8.9	1.54	0.01
Max. grade (g/t Au)	69.6	452.3	225.5
RSV	73%	297%	306%
Nugget effect	48%	ND	90%
Difference with respect to bulk sample grade	-	+28%	-46%

<sup>1</sup> Grades back-calculated to minimum mining width. ND: not determined.

As bulk sampling progressed, it was possible to undertake duplicate pair analysis. The results display a total sampling error of 44%, comprising a sampling component of 40% and analytical component of 18% (Table 7). These values indicate the validity of the bulk sampling approach, where a sampling component of 44% can be considered acceptable given the strongly clustered nature of the gold.

**Table 7. Bulk sample duplicate pair analysis.**

Sample Type/Error (Preparation Route)	Sampling (%)	Preparation (%)	Analytical (%)	Total (%)
	Individual rounds	-	-500 µm split	-
Bulk samples	40	-	18	44
Number of pairs	128	-	65	-

#### *Head Split Bulk Sample Grade Determination*

Given the reliance on full bulk sample processing, an alternate way of determining bulk sample grade was sought. A sub-sampling option was devised which ran the 15–30 t bulk sample through the primary and secondary crushers to achieve a  $P_{90}$  -4 mm product. A linear splitter was installed after the secondary crusher to take a 2.25 kg sample every 2.5 min. Multiple increments were considered the best option to increase the probability of gold being encountered in the split. For a 30 t bulk sample, an approx. 200 kg sub-sample was collected. This was then processed via a laboratory-based process unit, where a preliminary recovered grade was declared in approx. 6 hours from arrival at the plant. A 10 kg tails sample was collected manually from the Knelson concentrator underflow.

For the first 30 bulk samples, two head-splits were taken, and the remainder of each bulk sample processed in its entirety. The head grade of the 30 bulk samples (approx. 900 t) was 20.6 g/t Au and the grades of the two sets of head-splits were 19.2 g/t Au and 22.3 g/t Au respectively. These lie within  $\pm 10\%$  of the full bulk sample grade, which is an acceptable result.

Duplicate pair analysis of the head split bulk sample protocol yielded a total error of 57%, with relative components of 50%, 21% and 19% (Table 8). These values indicate that the protocol worked well, where clusters were broken down during crushing and multiple increments reduced periodic variability. The company opted not use this option routinely, as they wished to recover gold from the pilot plant for sale. The head split capability is available as required, including for batching material from other projects.

**Table 8. Bulk sample head-split duplicate pair analysis.**

Sample Type/Error (Preparation Route)	Sampling (%)	Preparation (%)	Analytical (%)	Total (%)
	Rounds	-4 mm split	-500 µm split	-
Bulk samples	50	21	19	57
Number of pairs	30	30	30	-

Pairs cover range of mineralisation grades from low to high.

#### Quality Assurance/Quality Control

QC for core and channel samples included the use of certified reference materials (CRM), blanks, pulp quality checks, umpire assays and duplicates.<sup>20</sup> CRMs were inserted at a rate of 1 in 20, and blanks inserted at a rate of 1 in 20 and after visible gold occurrences. Duplicates were collected at a rate of 1 in 20, though this varied depending upon the testwork being undertaken. Pulps were checked for quality at a rate of 1 in 20. Umpire pulp splits were taken at a rate of 1 in 30 and submitted to a second external laboratory. All samples (e.g. core, channel and grab) collected underground were removed to the on-site logging and sample preparation facility.

QC for the bulk sample circuit included blanks (2 t) at 1 in 15 and barren flushes (2 t) between all samples, which were assayed at a rate of 1 in 5. All concentrate and tails assays related to bulk sampling have the same QC as other samples. Samples going to the external laboratory were secured into boxes and transported by road in locked containers. QA documentation of activities included sample collection, security and transport, through to preparation and assaying. All QC results for the programme were in compliance.

#### FSE Analysis of Sample Protocols

An analysis for FSE was undertaken for each protocol applied at San Christina (Table 9). The highest error related to grab samples and the collection of 25 kg from a 30 t pile. The method was discontinued. The channel samples also displayed a high FSE relating to the splitting of the sample post-crushing.

**Table 9. Protocols and FSE for resource evaluation and mine development stages at San Christina. FSE calculations based on the 2019 BCOG (6.5 g/t Au) and run of mine grade scenarios (Table 2). The current BCOG is 5.5 g/t Au, thus the FSE values that are not zero are likely to be slightly higher than noted below. All FSE calculations are based on  $f = 0.30$ ;  $g = 0.25$  and  $\alpha = 1.5$ .**

Stage	Type	Protocol	<sup>1</sup> FSE	Comment
Resource evaluation	Core (half core)	Half NQ core (1.9–2.4 kg) crush to $P_{90}$ –3 mm Pulverise to $P_{95}$ –75 $\mu$ m and riffle split in half for 2x SFA1200	$\pm 0\%$	No FSE as entire sample prepared and assayed
			$\pm 0\%$	
Resource evaluation	Core (whole core)	Whole NQ core (2.8–4.8 kg) crush to $P_{90}$ –3 mm Pulverise to $P_{95}$ –75 $\mu$ m and riffle split in half for 2x LW2500	$\pm 0\%$	No FSE as entire sample prepared and assayed
			$\pm 0\%$	
Mine development	Face channel	5.4–6.7 kg crush to $P_{90}$ –3 mm, then RSD split off one third Pulverise to $P_{95}$ –75 $\mu$ m and RSD split into thirds for 2–3x SFA1000	$\pm 49\%$	Large FSE at post-crusher split
			$\pm 34\%$	
Mine development	Bulk (full sample pilot plant)	15–30 t crushed, pulverised and fed through gravity concentrator 36 kg of tails incrementally linear split at $P_{90}$ –500 $\mu$ m 6 kg RSD split and pulverised to $P_{90}$ –100 $\mu$ m for 6x SFA2000	$\pm 5\%$	Entire sample processed through plant FSE relates to tails sample splitting
			$\pm 5\%$	
Mine development	Bulk (head coarse split)	15–30 t primary and secondary crushed 200 kg incrementally linear split from the 30 t bulk sample at $P_{85}$ –4 mm 200 kg crushed, pulverised and fed through gravity concentrator 10 kg of tails incrementally collected at $P_{90}$ –500 $\mu$ m 10 kg RSD split and pulverised to $P_{95}$ –75 $\mu$ m, 2x 1 kg sub-samples taken for SFA1000	$\pm 15\%$	Most FSE relates to the primary split Recoverable gold grade determined from gravity concentrate FSE relates to tails sample splitting
			$\pm 25\%$	
Mine development	Grab	5 kg crush to $P_{90}$ –3 mm, then RSD split 2.5 kg Pulverise to $P_{95}$ –75 $\mu$ m and riffle split in half for 2x SFA1250	$\pm 305\%$	Sample collected at 5x 5 kg of sub-8 cm material Large FSE on collection of 25 kg from 30 t lot FSE given for entire process
			$\pm 205\%$	

### Reconciliation between Grade Control Sampling and Production

As part of the original evaluation phase, a trial mine shrinkage stope was extracted on the VC between levels 1 and 2. This yielded 2,692 t at a head grade of 26.7 g/t Au compared to an estimated 23.6 g/t Au via bulk sampling (Table 10).

**Table 10. Comparison between diamond drill, channel samples and bulk sample estimates for the VC trial (1-2 level) stope panel with the plant head grade. All estimated grades account for intentional and unintentional dilution.**

Sample Type	No. Samples	Total Assayed/Processed	Estimated Stope Grade (g/t Au)	Difference with Reconciled Grade
Diamond drill	5	39 kg	6.1	-77%
Face channel samples	44	891 kg	10.0	-63%
Bulk sample (full)	44	792 t	23.6	-12%
Reconciled head	-	2692 t	26.7	-

The bulk sample grade understated the plant head grade by 12%. Other estimates based on diamond core and face channel samples understated the plant head grade by >49% (Table 11). Production (including development and trial mining) yielded 75,840 t at 23.2 g/t Au against a bulk sample predicted grade of 17 g/t Au (Table 11). During this period, the bulk samples were more limited in number and distribution, often restricted to 2–6 per level totalling 65–200 t. The bulk samples still provided a better estimate of grade than drilling, though they under-called mined grade by 27%.

**Table 11. Reconciliation between reconciled plant head grade and diamond drill core and bulk sample estimates for the 2005–2012 period. All estimated grades account for intentional and unintentional dilution.**

Year	Tonnes Processed (t)	Reconciled Head Grade (g/t Au)	Predicted grade (g/t Au)	
			Drilling	<sup>1</sup> Bulk
2005–2006	6,460	19.6	4.0	15.1
2007	9,510	24.5	6.8	16.5
2008	10,740	19.2	4.5	14.9
2009	12,630	26.7	14.3	17.9
2010	12,980	23.6	9.2	17.7
2011	11,950	28.1	-	21.6
2012	11,570	18.3	-	13.9
Total	75,840	23.2	8.4	17.0
Difference to reconciled grade	-	-	-64%	-27%

<sup>1</sup> From Q2 2011 all bulk sample grades as head split samples.

## Sample Application and Resource Estimation

### Sampling Strategy

The most effective sample type were the bulk samples, given that they provide an estimate that is closer to that mined. Allowing for development drive width (2.5 m), the effective mineralised bulk sample mass is 18 t based on a minimum mining width of 1.5 m, a drive height of 2.5 m and advance of 1.8 m. They are generally large enough to overcome the high geological nugget effect driven by the gold particle clustering. All small sample types (e.g. drill core and channel samples) have a low probability of intersecting clusters.

For the 2018 programme, resources defined by consecutive development bulk samples were reported as Indicated Mineral Resources (6 month  $\pm 15$ –25%) and those solely by diamond core drilling as Inferred Mineral Resources (globally expected to be  $\pm 50$ %).<sup>28</sup>

### Resource Estimation based on Diamond Drilling

Diamond core drilling provides a method to evaluate reef location, geometry and internal characteristics. The 2018 resource estimate was based on 49 NQ holes, drilled on a 10–15 m by 10–15 m grid and whole core sampled (sampled separately as both halves). The programme yielded 106 reef whole-core composites with a total mass of 400 kg, where 14 holes contained visible gold and graded >15 g/t Au. An ordinary kriged block model yielded a global resource grade of 9.4 g/t Au, based on 5 m by 5 m estimation blocks. It is realised that global grade understates the mineable grade, which could be in the 22 g/t Au to 26 g/t Au range but provides confidence to commit to underground development.

The robust lower grade estimate likely reflects the presence of a finer more disseminated background gold population below 9 g/t Au (Tables 2, 3 and Figure 2). This mineralisation requires a lower sample mass (e.g. 30–35 kg; Table 13), where the number of samples informing a given block estimate will be >30 kg in total mass.

#### *Trial Mining of 4 Level South Veta Christina South*

Grade evaluation during 2019 has utilised development bulk sampling and full processing. An initial programme was undertaken on the VC between levels 3 and 4 (#2 shoot) in preparation for mining. A 70 m drive was developed along the reef, which varied in width from 1.25–1.50 m. Based on bulk sample grade and geological features, the ore shoot zone was represented by 55 m of strike, comprising 30 bulk samples. All bulk samples were processed through the pilot plant as a composite lot (e.g. all bulk samples, c. 982 t). All faces were channel sampled and mapped. Table 12 shows a comparison of sample types along the VC4 level drive.

**Table 12. Comparison between diamond drill, channel samples and bulk sample estimates for the VC4 #2 shoot bulk samples with the plant head grade. All estimated grades account for intentional and unintentional dilution.**

Sample Type	No. Faces/Samples	Total Assayed/Processed	Grade (g/t Au)	Difference with Bulk Sample Reconciled Grade
Face channel samples	31	633 kg	15.6	-36%
Bulk sample	30	982 t	24.5	-
Drill-only block model	-	-	9.4	-62%
Local block model (core and channel samples)	-	-	10.1	-59%

As observed previously (Tables 10 and 11), the block models based on drilling or drilling, and channel samples understate the bulk samples grades. The global bulk sample yielded 625 oz of gold bullion for sale. Between 2 and 4 levels (approx. 60 m vertically), bulk sampling defined an Indicated Mineral Resource of 16,500 t at 25.7 g/t Au to provide a base for mining over 6 months.

#### Activities Post-2019

##### *Additional Characterisation Work*

During 2020 two characterisation programmes were undertaken in 2020 along the VC6 #5 shoot drive. The first undertook a single selectively extracted bulk sample to collect by geological domain, across early (Figure 3; non-sulphide veining) and late (Figure 1; sulphide veining) veining, and barren wallrocks. To facilitate collection, the drive was stopped, and a side drive developed so that the target volume could be extracted across strike, from footwall to hanging wall. The domains were removed carefully with low explosives use to ensure minimal DE and EE. Some cross-contamination was inevitable but was considered less than a few percent based on visual inspection.

The two vein domains were sent to a commercial laboratory for pilot plant test work. The wallrock domain was processed via the mine plant, with head samples taken after the secondary crusher. The results of the study are presented in Table 13.

**Table 13. Grade and gold sizing results from the vein domain bulk samples.**

Domain	Width (m)	Tonnes (t)	Grade (g/t Au)	d <sub>maxAu</sub> (µm)	d <sub>95Au</sub> (µm)	d <sub>Auclus</sub> (µm)	#Clusters
Early	0.9	12.9	50.4	2,500	2,300	7,500	5-10
Late	0.4	5.5	37.5	1,200	1,100	-	-
Wallrocks	1.2 (HW + FW)	17.7	0.15	-	-	-	-
Total	2.5 (Drive width)	36.1	23.7	2,800	2,100	7,500	-

The data show that the Early domain is of a higher grade and contains coarser gold with clustering, whereas the Late domain contains a lower gold particle sizing with no clusters (Figure 14). A theoretical field sample mass was estimated using Poisson statistics to achieve a given precision (e.g. ±15% at 90% reliability).<sup>25</sup> The results are presented in Table 14, with the highest masses related to the clustering. As with the previous estimate of representative sample mass (Table 3), the clustering is the key driver of a high mass requirement and further validates the bulk processing approach to evaluation.

**Table 14. Range of theoretical sample mass values for the vein domains.**

Domain	Grade (g/t Au)	d <sub>95Au</sub> / [d <sub>Auclus</sub> ] (µm)	Sampling constant (K)	Optimum mass
Early phase	50.4	2,300	3,000	230 kg
		7,500	17,400	8 t
Late phase	37.5	1,200	1,500	45 kg
Combined drive (Diluted round)	23.7	2,100	5,500	365 kg
		7,500	37,000	16 t

The second test programme was undertaken to determine the gold grade by size fraction of a blasted development round. An expected high grade round was selected, screened on site to seven size fractions, which were shipped to a commercial laboratory for pilot plant test work. The results of the granulometric study are presented in Table 15. The bulk sample head grade was 36.3 g/t Au. The sub-15 mm fraction represents 31% of tonnes and contains 39% of the gold. The >15 mm fraction represents 69% of the tonnes and contains 61% of the gold (Table 15).

**Table 15. Granulometric analysis of a bulk sample of blasted VC ore.**

Size fraction	Fraction mass (t)	Fraction grade (g/t Au)	Mass fraction (%)	Contained gold (%)
-3 mm	3.3	55.6	9	14
3 to 6 mm	2.7	44.9	8	10
6 to 15 mm	5.3	38.7	15	16
15 to 25 mm	3.9	36.5	11	11
25 to 50 mm	6.6	46.9	18	24
50 to 100 mm	9.3	28.4	26	20
>100 mm	4.7	15.6	13	6
Total	35.8	36.3	-	-

The nominal fine fraction (~15 mm) shows high grades, but not substantively different from the coarser material, particularly >25 mm. In many cases the fines fractions are enriched relatively to the coarser material with the risk of gold loss on drive and stope floors.<sup>27</sup> In this case there is some risk of gold loss on drive floors. What is more interesting is that the higher grades in the >25 mm material may represent gold clusters. Clustering was verified by inspection of the larger (>50 mm) size fractions after screening.

## Production

Since commencement of mining in May 2019, production has increased to 41,000 t per annum to produce over 27,000 oz Au recovered (Table 16). Over the next 12 months the operation will ramp up to 50,000 t per annum targeting 33,000 oz Au recovered. Mining continues via shrinkage stoping, with long hole stoping under trial.

**Table 16. Production figures for the period 2019-2022.**

Year	Tonnes mined (t)	Estimated grade (g/t Au)	Actual head grade (g/t Au)	Actual / estimated grade	Recovered ounces Au
2019 (8 months)	18,575	19.9	23.0	+16%	12,776
2020	34,254	20.2	23.7	+17%	24,328
2021	41,782	19.4	21.9	+13%	27,804
2022 (3 months)	10,257	22.2	24.6	+11%	7,650

The process plant was upgraded to 8 t per hour capacity (targeting 60,000 t per annum), and a floatation circuit added to improve recovery to 93–95%. The original gravity-only pilot plant has been retained and can be fed directly from the plant feed conveyor post-crushing circuit. A new laboratory was built 25 km from the mine and is shared with two other operations. The laboratory is capable of undertaking FA30–50 and SFA1000–5000, including all sample preparation.

Historical and current sampling methods are summarised in Table 17. The definition of Inferred Mineral Resources continues to be via diamond core drilling at a 10–20 m grid producing HQ core. All assays are whole core by single or multiple SFA. Indicated Mineral Resources are defined via development bulk sampling.

As the reef is developed, digital mapping indicates the present of the ore shoot. Saw-cut channel samples are collected from faces as and when deemed necessary to assist with orebody knowledge. The channel samples provide a good representation of grade trends within the ore shoot and assist in the location of low grade zones.

Development rounds are stockpiled at the plant until the shoot strike length has been developed. This is generally 50 m to 100 m, producing a mill parcel of between 1,800–3,500 t. The parcels are fed through the process plant and reconciled. Each 1.8 m of “on ore” development round delineates c. 185 t of stope ore and 35 t of development ore, based on a 25 m backs-to-floor separation. A dedicated team provides 24/7 cover for waste and vein development with an annual capability of 1,100 m. Some 55% will be on ore, 15% on low grade vein (waste), and 30% in wallrocks (waste). The “on ore” development yields approximately 12,000 t of ore (processed for evaluation purposes), and 62,000 t of stope ore per annum.

Based on a current (June 2022) BCOG of 5.5 g/t Au, selective mining is practised only to the extent of excluding low grade zones from stope design (e.g. use as pillars). In general <15% of the shoot is left behind because it is below the BCOG.

**Table 17. Summary of sample types used at San Christina.**

Type	Stage	Period	Comment
Core (half)	Evaluation	2005–2011	Discontinued
Core (whole)	Evaluation	2011–2012 2019	Targeting and preliminary resource estimate Continued in 2019 for Inferred Mineral resource estimation
Channel: hand cut)	Evaluation	2005–2006	Discontinued in 2006
Saw cut		2019	Applied in 2019 for comparison. Used as required at present
Grab	Production	2005–2006	Discontinued
Bulk (full)	Evaluation	2005–2012 2019	Replaced by bulk (split) option in 2011 Continued in 2019, currently processed as full drive parcels along the ore shoot
Bulk (head split)	Evaluation	2010–2012 2019	Introduced to speed up development grade determination Can be used if required

The option to split off a plant-feed head sample is applied as and when required (Table 9). If geological observation and mapping during development indicates a likely lower grade zone, then this may be instigated. As the given development rounds are fed to the plant, cuts are taken for assay. This approach provides a local head grade but does not stop the plant operating.

The operation has also instigated a tactical geometallurgical programme to provide prediction of key ore properties to the plant. Beyond grade, the work aims to provide block models of metallurgical recovery (gravity and flotation), ore hardness, density, and various geochemical elements.<sup>30</sup> In addition, a programme of drive floor sampling is being undertaken to review gold loss in broken ore residues. The programme initially involves collecting



thirty 250 kg samples from a recently stopped-out drive to achieve a composite mass of c. 7.5 t.<sup>29</sup> Individual 250 kg samples are being reduced to 20 kg and run through a laboratory Knelson concentrator for gold determination. Initial results of a few samples display residues grades of between 11.5–31.4 g/t Au.

## Discussion

The San Christina reefs bears coarse gold-dominated mineralisation, where >65% of the gold is present in particles with a size greater than 100 µm for grades above 6 g/t Au. However, gold rarely occurs >2,000 µm in size, the maximum gold particle size observed being 2,500 µm. Traditional sampling methods such as face channel and diamond drill core samples understate the mean gold grade by 65% to 75%. This relates to gold particle clustering for grades nominally >6 g/t Au, where clusters of 0.5 cm to 2 cm of >200 µm gold increase the geological nugget effect. Given that at a run of mine grade tonne of ore may contain 1–5 gold clusters that contain up to 80% of the grade, the probability of intersecting zero clusters is >95% for core and channel samples. These small samples fail to intersect the sparse clusters but will yield extreme value grades if they do. Several sample types have been trialled at the project (Table 17).

Based on a Poisson-based probabilistic method, a representative sample mass up to 85 t (worst case scenario) may be required to achieve a precision of ±15% at 90% reliability.<sup>25</sup> The very large sample mass is driven 1–2 cm gold clusters within run of mine grade mineralisation. If these clusters did not exist, then a run of mine grade sample mass of 150–500 kg may be appropriate.

Given the challenges of small volume samples, a development drive bulk sampling programme was instigated where entire development blasts of approx. 35 t were taken and processed in their entirety through a surface plant. The composited bulk sample grades along the upper and lower drives of stopes provide a reliable estimate of stope grade. The current approach is to batch entire development parcels through the plant. Individual development round bulk samples are not processed individually, unless their grade is required (for example if it is believed to be low grade), then a head sample is collected after the secondary crusher. A risk review of the bulk sampling method used to support Indicated Mineral Resource estimation is provided in Table 18.

**Table 18. Risk review of the San Christina bulk sampling programme used for Indicated Mineral Resource definition. During the original 2018 evaluation programme, individual development bulk samples were processed through the pilot plant.**

Key Parameter		Comment	<sup>1</sup> Component Error	TOS Error	<sup>2</sup> Error Rating
1	Spatial distribution and number of samples	Samples collected along drives. Vertical drive separation approx. 30 m. Each stope block (~3,500–5,000 t) informed by between 20-55 bulk samples per level	40%	GNE	Low-mod.
2	Sample mass (representativity)	Each development round bulk sample 35 t; total sample mass collected around a stope block ranges between approx. 1,000–2,000 t per level Indicated optimum mass around 35 t to achieve 90% ±15% at ROM for clustered gold. Total lot currently processed through the plant			Low-mod.
3	Collection and handling	Sample extracted by blasting Sample collection by mechanised mucking unit. All samples transported to surface and kept separate prior to crushing and splitting	18%	-	Low
4	Transport and security	Samples delivered directly from the mine to the plant stockpile area		-	Low
5	Preparation	Entire sample crushed and pulverised Plant cleaned and flushed between samples	18%	-	Low
6	Assay	Entire sample passed through gravity circuit Gold concentrates weighed and sent for fire assay to extinction Preparation and analytical error relate to tails sample split and assay		-	Low
7	QAQC	Duplicates and blanks within expectation CRMs within expectation Written protocols for the sampling-assaying process	-	-	Low
8	Validation/v ariability indicators	Individual bulk sample RSV 65% Individual bulk sample nugget effect 49% Stope grade reconciliation ±20% on a quarterly to annual base Indicated Mineral Resources defined	Total 44%	-	Low
Summary					
Sample representativity (1)–(3)					Mod.
Preparation and assay (4)–(7)					Low
Fit-for-purpose					Yes

## Conclusions

This contribution demonstrates that effective sampling is critical for resource evaluation and grade control. Grade control is about adding value by delivering quality tonnes to the mill via the accurate definition of ore and waste. The magnitude of measurement error (e.g. the sum of the sampling, preparation and analytical relative errors) during grade control is a critical consideration, as it can undermine the quality of resource/reserve estimates and any decisions made thereon.

The case study presents an analysis which commences with evaluation of ore characteristics (e.g.  $d_{95Au}$ ), duplicate sample pairs (e.g. relative error determination), sampling protocols in the context of TOS, and programme performance via reconciliation. A table-based method is presented to evaluate the fit-for-purpose nature of the programmes (Table 19).

**Table 19. Stages in the design of a new grade control programme and for the review of an existing programme. Detail may differ depending upon circumstances (after Dominy et al.).<sup>1</sup>**

Stage	New programme
1: Overview	Set programme goals and data quality objectives
2: Characterise	Review existing characterisation data and determine grade-liberation diameter relationships and critical optimisation grade Plan and undertake addition testwork if required
3: Design or review	Apply Stage (2) data to design protocols, including TOS-FSE analysis Undertake duplicate pair analysis (if possible)
4: Implement	Set-up systems and written codes of practice Training of mine geology and production staff
5: Monitor	On-going QAQC programme with timely review and action as required Annual internal and/or external peer review Review resource/reserve reconciliation Risk analysis
6: Update	On-going training Revision of protocols if required, return to Stage 2 or 3 as required

Case specific conclusions are:

- At San Christina, small-sample based assays understate grade in geometrically simple, coarse gold-dominated veins. Drilling with whole core sampling and assaying is applied to estimate Inferred Mineral Resources that are accepted to understate grade by 50–65% - a compromise. The under-called blocks are only reported above the BCOG with the knowledge, based on experience, that they will provide a higher grade during mining. Those blocks less than the BCOG, generally do reflect low grade mineralisation.
- Dominant gold particle clustering drives the application of bulk sampling. Development drives are batch sampled and processed via an on-site plant. Upper and lower development drive grades are assigned to stope blocks and reported in the Indicated Mineral Resource category.
- The mine operator is a privately owned entity. Given that the company is not required to publicly report its resources, the extensive sampling regime may appear to be excessive. However, the group has several international investors, and the owners may ultimately opt to list the company. Importantly, they understand that quality data underpins quality decisions and require all its technical activities to be carried out to optimum practice. Their investment has been validated by the success of the operation since 2019.
- The need for a strong and integrated technical team cannot be over-stated.

General conclusions include:

- A range of sampling methods are available for underground mine resource development and grade control, all of which require evaluation before routine application. The highest error is generally introduced during sample collection. A reduction in the need for chip or channel samples will only come from the use of more pre-development drilling at a spacing to allow local estimation.
- Application of TOS enables sampling programme design and practice to be optimised. All errors along the sampling value chain are additive and impart variability making local estimation less reliable. Estimation must consider the sampling strategy, with sample quality reflected in the resource classification.
- A truly representative sample probably does not exist, since extensive and often heterogeneous geological entities are being evaluated. Characterisation studies undertaken to support sampling programme design are unlikely to represent the mineralisation in question, though will generally provide better outputs than so-called heterogeneity studies. However, a best as practical characterisation programme is better than no characterisation. Samples must be collected within the framework of TOS. Technical teams should consider bulk sample and piloting programmes to evaluate grade and metallurgy as part of pre-feasibility or feasibility studies. This is particularly relevant where strong variability relates to mineralogical and/or textural complexities that impact on recovery.
- For high grade operations (nominally >15 g/t Au ROM), imposition of a BCOG may be unnecessary where ROM grades are >>BCOG.

- Characterisation samples should be undertaken early in the mine value chain to assess ore properties. Sampling, testwork and assaying programmes should be designed to support Mineral Resources and Ore Reserves that will be reported in accordance with the 2012 JORC Code (or other international reporting code). To ensure fit-for-purpose data, rigorous QAQC must be developed to support sampling and testwork. QAQC cannot be divorced from the TOS and is a mandatory step for fit-for-purpose assay results.
- There is a need for the quantification of sampling and analytical errors to better communicate uncertainty and risk. A first step is the application of the protocol pro forma and RSV metric presented in DS3077.<sup>31</sup> Resolution of component relative errors across sampling, preparation and analysis can be gained from duplicate sample pairs. A simple tabular tool is presented to communicate key sampling programme risks.

## Acknowledgments

The authors acknowledge the mine owner/operator OCX Gold Group. This case study was compiled within a confidentiality agreement. Input of the San Christina operating company and technical team under the leadership of Peter Mendes is acknowledged. Dr Jon Davies is thanked for various iterations of the San Christina resource, reserve and grade control models. Professor Kim Esbensen is thanked for comments on the manuscript, and Dr Anne Cole for assistance with formatting.

## Abbreviations

The following abbreviations are used in this manuscript:

AE	Analytical error
BCOG	Breakeven cut-off grade
CRM	Certified reference material
DE	Delimitation error
$d_{95Au}/d_{Auclus}$	Liberation diameter for sampling purposes, individual particle vs. clustered value
EE	Extraction error
FA	Fire assay (assay charge size 30 g; FA30)
FSE	Fundamental sampling error
LW	LeachWELL assay method
$P_{90}$ or $P_{95}$	Percent passing (e.g., $P_{90}$ : 90% passing a given screen size)
PE	Preparation error
ROM	Run of mine grade
RSD	Rotary sample divider
RSV	Relative sampling variability
SFA	Screen fire assay (assay charge size 500 g; SFA500)
TOS	Theory of Sampling
QAQC	Quality assurance/quality control

## ORCID IDs

S.C. Dominy:	<a href="https://orcid.org/0000-0002-0638-3693">https://orcid.org/0000-0002-0638-3693</a>
H.J. Glass:	<a href="https://orcid.org/0000-0002-2015-2461">https://orcid.org/0000-0002-2015-2461</a>
S. Purevgerel:	<a href="https://orcid.org/0000-0003-0625-9518">https://orcid.org/0000-0003-0625-9518</a>

## References

1. S.C. Dominy, I.M. Platten, Y. Xie and R.C.A. Minnitt, "Underground grade control protocol design: Case study from the Liphichi gold project, Larecaja, Bolivia", *Appl. Earth Sci.* **119**, 205–219 (2011). doi.org/10.1179/1743275811Y.0000000016
2. S.C. Dominy, H.J. Glass, C.K. Lam, L. O'Connor, S. Purevgerel and R.C.A. Minnitt, "Integrating the Theory of Sampling into underground grade control strategies", *Minerals*. **8** (2018). doi.org/10.3390/min8060232.
3. F.F. Pitard, "*Theory of Sampling and Sampling Practice*", CRC Press, pp. 694 (2019).
4. S.C. Dominy, L. O'Connor, H.J. Glass, S. Purevgerel and Y. Xie, "Towards representative metallurgical sampling and recovery testwork programmes", *Minerals*. **8** (2018). doi.org/10.3390/min8050193
5. S.C. Dominy, L. O'Connor and S. Purevgerel, "Importance of representative metallurgical sampling and testwork programmes to reduce project risk-a gold case study", *Mining Technol.* **128**, 230–245 (2019) doi.org/10.1080/25726668.2019.1628462
6. P.C. Carrasco, P. Carrasco and E. Jara, "The economic impact of incorrect sampling and analysis practices in the copper mining industry", *Chemom. Intell. Lab. Sys.* **74**, 209–214 (2004). doi.org/10.1016/j.chemolab.2004.04.013
7. P.M. Gy, "*Sampling of Particulate Materials: Theory and Practice*", Elsevier, p. 431 (1982).
8. D.M. François-Bongarçon and P.M. Gy, "The most common error in applying Gy's formula in the theory of mineral sampling and the history of the Liberation factor", *J. South. Afr. Inst. Min. Metall.* **102**, 475–479 (2002).
9. R.C.A. Minnitt, "Sampling: The impact on costs and decision making", *J. South. Afr. Inst. Min. Metall.* **107**, 451–462 (2007). doi.org/10.10520/AJA0038223X\_3284
10. S.C. Dominy, "Importance of good sampling practice throughout the gold mine value chain", *Min. Technol.* **125**, 129–141 (2016). doi.org/10.1179/1743286315Y.0000000028
11. G.J. Lyman and F.S. Bourgeois, "Sampling, corporate governance and risk analysis", *We are Metallurgists not Magicians: Landmark Papers by Practicing Metallurgists*. AusIMM, pp. 349–354 (2017).
12. S.C. Dominy and I.M. Platten, "Clustering of gold particles and implications for sampling", *Appl. Earth Sci.* **116**, 130–142 (2007). doi.org/10.1179/174327507X207474
13. S.C. Dominy, I.M. Platten, H.J. Glass, S. Purevgerel and B.W. Cuffley, "Determination of gold particle characteristics for sampling protocol optimisation", *Minerals*. **11**, 1109 (2021). doi.org/10.3390/min11101109
14. S.C. Dominy, "Predicting the unpredictable – evaluating high-nugget effect gold deposits", in *Mineral Resource and Mineralisation Reserve Estimation – The AusIMM Guide to Good Practice, Monograph #23*. AusIMM, pp. 659–678 (2014).
15. S.C. Dominy and J.S. Petersen, "Sampling coarse gold-bearing mineralisation - developing effective protocols and a case study from the Nalunaq mine, southern Greenland", in *Proceedings Second World Conference on Sampling and Blending*. AusIMM, pp. 151–165 (2005).
16. S.C. Dominy, L. O'Connor, H.J. Glass and Y. Xie, "Geometallurgical study of a gravity recoverable gold orebody", *Minerals*. **8(186)** (2018). doi.org/10.3390/min8050186
17. C.R. Stanley and D. Lawrie, "Average relative error in geochemical determinations: Clarification, calculation and a plea for consistency", *Explor. Min. Geol.* **3–4**, 267–275 (2007). doi.org/10.2113/gsemg.16.3-4.267
18. C.R. Stanley and B.W. Smee, "Strategies for reducing sampling errors in exploration and resource definition drilling programmes for gold deposits", *Geochem. Explor. Environ. Anal.* **7**, 329–340 (2007). doi.org/10.1144/1467-7873/07-128
19. M.Z. Abzalov, "Quality control of assay data: A review of procedures for measuring and monitoring precision and accuracy", *Explor. Min. Geol.* **3–4**, 131–144 (2008). doi.org/10.2113/gsemg.17.3-4.131
20. S.C. Dominy, S. Purevgerel and K.E. Esbensen, "Quality and sampling error quantification for gold mineral resource estimation", *Spec. Europe.* **32**, 21–27 (2020).
21. D.M. François-Bongarçon, "Theory of sampling and geostatistics: An intimate link", *Chemom. Intell. Lab. Syst.* **74**, 143–148 (2004). doi.org/10.1016/j.chemolab.2004.03.015
22. JORC Code, "*Joint Ore Reserves Committee (JORC), Australasian Code for Reporting of Exploration Results, Mineral Resources and Ore Reserves—The JORC Code*", Joint Ore Reserves Committee of the Australasian Institute of Mining and Metallurgy, Australian Institute of Geoscientists and Minerals Council of Australia, p. 44 (2012).
23. S.C. Dominy and Y. Xie, "Optimising sampling protocols via the heterogeneity test: challenges in coarse gold mineralisation", *Min. Technol.* **125**, 103–113 (2016). doi.org/10.1179/1743286315Y.0000000011
24. R.C.A. Minnitt and W. Assibey-Bonsu, "A comparison between the duplicate series method and the heterogeneity test as methods for calculating the sampling constants", *Journ. S. Afr. Inst. Min. Metall.* **110**, 251–268 (2010).

25. S.C. Dominy, I.M. Platten and Y. Xie, "Determining gold particle size in gravity ores for sampling and metallurgical characterisation: discussion and test protocol", in *Proceedings of the Gravity Gold Conference*. AusIMM pp. 83–95 (2010).
26. S.C. Dominy, I.M. Platten and Y. Xie, "Bulk sampling of complex gold deposits: material characterisation and programme design and management", in *Proceedings Sampling Conference*. AusIMM, pp. 41-57 (2008).
27. S.C. Dominy, A. Van Roij, J.C. Graham and Q.T. Hennigh. "Sampling of high-nugget conglomerates from the Western Australian Pilbara: Bulk sampling at the Beatons Creek gold project, Nullagine", in *Proceedings of the World Conference on Sampling and Blending*. IM Publications, this volume (2022).
28. S.C. Dominy and W.B. Edgar, "Approaches to reporting grade uncertainty in high nugget gold veins", *App. Earth Sci.* **121**, 29–42 (2012) doi.org/10.1179/1743275812Y.0000000013
29. S.C. Dominy and H.J. Glass, "Sampling broken ore residues in underground gold workings: implications for reconciliation and lost revenue", *Minerals*. Submitted/in review (2022).
30. S.C. Dominy, L. O'Connor, H.J. Glass and S. Purevgerel, "Strategic and tactical geometallurgical application in an underground high-grade narrow-vein gold operation", in *Proceedings MPES 2019*. Springer, pp 165-174 (2020). doi.org/10.1007/978-3-030-33954-8\_20
31. DS3077, "Representative Sampling–Horizontal Standard", Danish Standards Foundation, p. 41 (2013).



## The sampling and phase characterisation of black mass

Laurance Donnelly<sup>a</sup>, Duncan Pirrie<sup>b</sup>, Matthew Power<sup>c</sup>, Ian J Corfe<sup>d</sup>, Jukka Kuva<sup>d</sup>, Sari Lukkari<sup>d</sup>, Yann Lahaye<sup>d</sup>, Xuan Liu<sup>d</sup>, and Alan R Butcher<sup>d</sup>

<sup>a</sup>Head of Technical Department, Chief Geologist, AHK International Ltd, Kings Business Park, Prescot, Knowsley, UK, L341PJ, United Kingdom and Chair, International Union of Geological Sciences (IUGS), initiative on Forensic Geology (IFG), laurance.donnelly@ahkgroup.com

<sup>b</sup>School of Applied Sciences, University of South Wales, Pontypridd, CF374BD, UK

<sup>c</sup>Vidence Inc., Burnaby, British Columbia, Canada

<sup>d</sup>Circular Economy Solutions Unit, Geological Survey of Finland, Espoo, FI-02151, Finland

**'Black mass' is the industry term used to describe a type of e-waste comprising crushed and shredded battery cells. It is an intermediate product in the recycling of spent, end-of-life, batteries. It comprises a mixture of metals including; lithium, manganese, cobalt and nickel, which are valuable recycling commodities, of increasing strategic and economic importance to meet future global demands in the 'battery revolution'. The objective of this 'phase characterisation' investigation was to provide an indicative profile of the morphological characteristics, grain size, composition and textural variability for a natural state (unprepared) and prepared (powdered) sample of black mass from Europe. It is envisaged that this is relevant to: (a) develop a pragmatic sampling strategy to ensure a non-biased, representative sample is provided for assaying; (b) determine the optimal processing route (e.g., hydrometallurgical, pyrometallurgical); (c) identify the presence of payable phases; (d) identify phases that may hinder metal recovery or penalty components; (e) develop assay procedures; and (f) assist in the identification of hazards and the mitigation of risks. The techniques used were: (1) visual examination and binocular microscopy; (2) manual scanning electron microscopy (SEM); (3) automated scanning electron microscopy with linked energy dispersive spectrometers (SEM-EDS), to characterise the phases present and particle types (using AMICS); (4) X-ray computed tomography (X-CT) to provide the 3D morphology of the particles; and (5) laser ablation inductively-coupled plasma mass spectrometry (LA-ICP-MS) to detect and quantify the phases that cannot be detected using automated SEM-EDS and X-CT. The results demonstrated that automated SEM-EDS can be used to characterise and quantify the phases present, and the phase chemistry allows the particle types to be assigned back to the primary battery components. Some phases identified are at present not linked back to the original components and further work is needed to refine the compositional groups, with the analysis of additional samples from different feeds/streams in Europe, China and USA. Interactive SEM-EDS analysis also demonstrated that there is a high-resolution chemical variability within the individual particle categories. X-CT imaging demonstrated the complex 3D textures and morphology of the particles, which is potentially significant during sample preparation and chemical analysis. Neither automated nor manual interactive analysis can determine the presence / abundance of the light elements, such as lithium. However, LA-ICP-MS was successful in detecting and quantifying lithium. Furthermore, LA-ICP-MS was able to determine contents of 67 other non-metals and metals at a 20-micron scale with ppm to ppb level detection limits.**

### Introduction

With the increased global demand for personal electronic devices (e.g., smart phones, computers and flat screen televisions), along with the energy transition away from conventional fossil fuels (e.g., oil, gas, coal) to electric vehicles (EV) it is predicted that there will be an enormous growth in demand for lithium-ion batteries (LIBs) (known as the 'battery revolution'), with the market value of LIBs being \$29.86 billion in 2017, but projected to increase to \$139.36 billion by 2026 (<sup>1</sup>Chen et al., 2019). Given both; (a) the geological scarcity of battery raw materials and (b) increased requirements for sustainability and waste recycling, there is a huge potential in the recycling of LIBs (<sup>2</sup>Harper et al., 2019) with a projection that 4 million metric tons of LIB waste from EV batteries could be generated from 2015 to 2040 (<sup>3</sup>Or et al., 2019).

Existing recycling plants typically have a capacity of a few thousand tonnes, but this is expected to increase hugely (<sup>4</sup>Bruckner et al., 2020). During the recycling of LIBs and other e-waste such as printed circuit boards, the materials are sorted, dismantled and then processed. Following physical and thermo-mechanical processing a fine-grained powder, referred to as 'black mass' is generated (<sup>5</sup>Vanderbruggen et al., 2021). This black mass is the feed for subsequent hydrometallurgical or pyrometallurgical processing (e.g., <sup>1</sup>Chen et al., 2019; <sup>4</sup>Bruckner et al., 2020; <sup>6</sup>Werner et al., 2020) to recover the elements of value. Given the variable nature of the recycling feed the materials produced for processing are complex and highly variable. Significant variation in bulk chemistry, particle types and potential penalty elements may be expected.

Limited research has to date been published on the detailed characterisation of black mass (<sup>5</sup>Vanderbruggen et al., 2021), although there is very active research into the processing options for LIB materials (e.g., <sup>7</sup>Barik et al., 2017; <sup>4</sup>Bruckner et al.,



2020; <sup>1</sup>Chen et al., 2019; <sup>8</sup>Diekmann et al., 2017; <sup>9</sup>Friedrich and Schwich, 2020; <sup>10</sup>Liu et al., 2020; <sup>11</sup>Lu et al., 2017; <sup>12</sup>Pinegar and Smith, 2019; <sup>13</sup>Ruismaki et al., 2020; <sup>14</sup>Schwick et al., 2020; <sup>15</sup>Widijatmoko et al., 2020). It is widely recognised that the variability in the composition of the black mass feed, can significantly affect the efficiency of the processing and recovery (e.g., <sup>4</sup>Bruckner et al., 2020; <sup>8</sup>Diekmann et al., 2017).

## Objectives

The objectives of the analysis and phase characterisation of samples of black mass are to provide an initial and indicative profile of the morphology, grain size, composition and morphological characteristics of the black mass particles. This characterisation may aid in the determination of appropriate future sampling, sample preparation, assay and analysis routes.

## What is Black Mass?

Black mass is the term given to processed material, such as battery cells or from the crushing and preparation of electronic scrap (e-scrap). The black mass is thought to typically consist of different ratios of mixtures of metals, including lithium, manganese, cobalt and nickel and other phases in different ratios. In general, lithium-ion batteries comprise cells with a cathode and an anode with a polymer separator (<sup>5</sup>Vanderbruggen et al., 2021). Black mass is the industry term for a type of electronic waste (e-waste), which essentially comprises shredded lithium-ion batteries (LIB) and is an intermediate product in the recycling of spent batteries. Black mass is used to recover metals including cobalt, lithium and nickel, to produce new LIBs. Black mass represents about 30% by weight of the original batteries and is a tradable feedstock for pyrometallurgical and hydrometallurgical processes. Relatively little is understood about the characterisation, properties, variability and behaviour of the different types of black mass. The electrodes consist of a conductive foil coated by active particles. Most commonly the anode comprises copper foils and spheroidized natural graphite, whilst the cathode is usually made up of lithium metal oxide particles on aluminium foil. These cell components are tightly packed together and adhered with an organic binder.

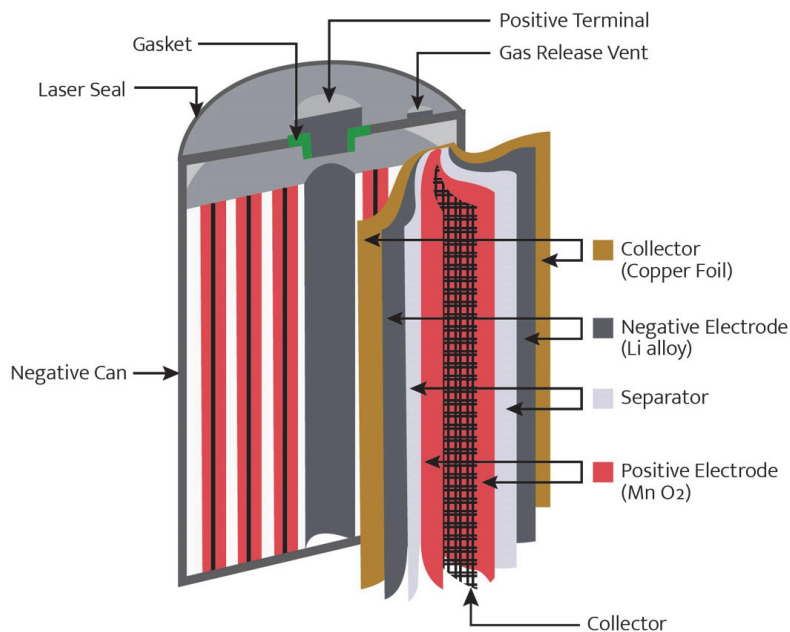

**Figure 1. Typical internal structure showing the components of a lithium-ion battery (LIB).**

## Components of Black Mass

The typical components of a LIB are presented in Figure 1. As such, the LIB components, which may be present within a black mass powder, in terms of their functional form, comprise the following:

- The casing,
- Graphite,
- Aluminium foil,
- Copper foil,
- Lithium metal oxides.

In addition, the lithium metal oxides making up the cathodes are divided into five main cathode types, based on their chemistry as follows:

- NMC (LiNiMnCo oxides),
- LCO (LiCo oxides),
- LM(N)O (LiMn(Ni) oxides),
- LFP (LiFe phosphates),
- NCA (LiNiCoAl oxides).

**Production of Black Mass**

With the increased use of Li ion batteries, there is a significant body of research focussed on developing methodologies for the reprocessing and recovery of the different battery components (e.g., see the RWTH Aachen University research centre ‘Production Engineering of E-Mobility Components or PEM). At the start of the recycling process the batteries will be discharged and then after removing the housing cover, the battery will be disassembled (Figure 2).

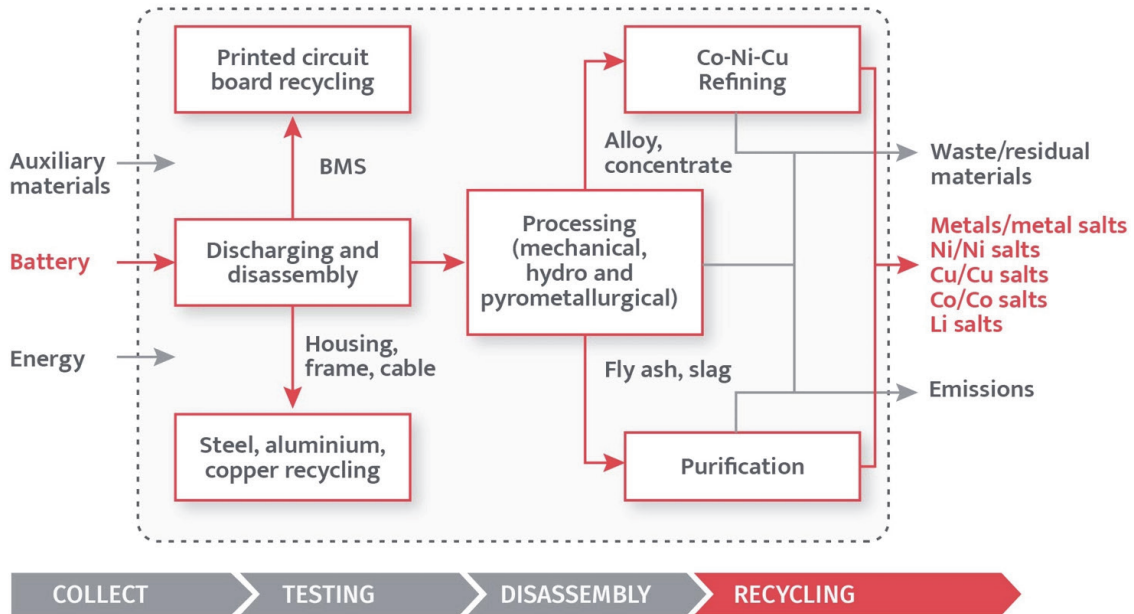

**Figure 2. Initial stages in the recycling of LIBs. Note, BMS is a battery management system utilised for the safety operation of the battery pack. It basically monitors the battery to make sure it doesn't operate outside the set safety limits.**

Following disassembly, the materials go through a series of mechanical recovery stages including crushing and drying, sorting, sieving and repeated crushing. The shredded battery material is reduced in size with the formation of a mixed powder residue, known as 'black mass' (Figure 3). Prior to mechanical reprocessing, cell deactivation or treatment of the black mass can be carried out by pyrolysis. Black mass can be pyrolyzed at up to 700°C after separation from the shredded material to remove the electrolyte components. This stage removes the fluorine-containing components. The resultant black mass is then commonly treated in a way analogous to a mined ore concentrate, with the elements of interest recovered through either a pyrometallurgical or hydrometallurgical processing route.



**Figure 3. Mechanical stages of LIBs recycling.**

There is considerable current research examining different process routes for the black mass powders. For example, <sup>7</sup>Barik et al. (2017) examined the leaching and separation of cobalt and manganese from shredded spent LIBs using HCl, with the step wise reprecipitation of the manganese and cobalt through the use of different reagents. <sup>4</sup>Bruckner et al. (2020) reviewed the metallurgical processing routes available for industrial recycling of LIBs; they noted that one of the challenges to such operations is the inhomogeneous feed. <sup>8</sup>Diekmann et al. (2017) also note that one of the challenges is the variable chemistry of the feed and noted that LFP cathodes cannot be reprocessed together with NCM cathodes. <sup>10</sup>Liu et al. (2020) explored the recovery of LiCoO<sub>2</sub> and graphite through cryogenic grinding and the use of froth flotation; froth flotation was also discussed as a means to achieve cobalt recovery by <sup>13</sup>Ruismaki et al. (2020). <sup>12</sup>Pinegar and Smith (2019) examined the optimal shredding and milling of LIBs needed to achieve liberation of the different components.

As highlighted by several authors, the complexity and heterogeneity of the battery components and resultant black mass powders, is a significant challenge in terms of designing optimal sampling methods, sample preparation and processing routes. Consequently, previous studies (e.g., <sup>16</sup>Zielinski et al., 2020; <sup>11</sup>Lu et al., 2017; <sup>17</sup>Otsuki et al., 2019) have demonstrated that a multi-analytical methodology is required for the characterisation of e-waste. <sup>16</sup>Zielinski et al. (2020) used quantitative electron microprobe elemental mapping to identify different compositional groups, whilst <sup>5</sup>Vanderbruggen et al. (2021) utilised automated SEM-EDS using a Tescan TIMA system to determine the phase characteristics. A multi-analytical methodology for the characterisation of recycled batteries (e.g., <sup>16</sup>Zielinski et al., 2020), batteries prior to recycling (<sup>11</sup>Lu et al., 2017) and also printed circuit boards (<sup>17</sup>Otsuki et al., 2019) has previously been recommended. The phase characterisation of black mass and the results of preliminary research were provided by <sup>18,19</sup>Donnelly et al. (2021a, 2021b).

## Potential Hazards Associated With Black Mass

The hazards associated with black mass and spent lithium-ion batteries (LIB) are relatively poorly understood. This is complex due to the variable characteristics and especially with mixed waste streams. However, anecdotal accounts supported by commissioned research conducted in Scandinavia (<sup>20</sup>Nissi 2019) suggests LIB recycling and some types of black mass might be residually hazardous:

- **Toxicity and corrosive:** Fluorine-containing compounds occur in the electrolyte, separators, and electrode materials. Fluorophosphates found in electrolyte may thermally decompose if heated above 50°C and can result in the formation of hydrofluoric acid (HF), when in contact with water. Similarly, polyvinylidene fluoride (PVDF) coatings are used as both electrode binders of the active materials and as coatings on separators, and above approximately 400°C may decompose to hydrogen fluoride gas (and hydrofluoric acid if water is present). Hydrofluorine and HF have serious health risks and may be toxic and corrosive to living tissue and bone.
- **Fumes:** Over 5 ppm exposure of HF in the workspace air causes irritation of eyes, skin, mucous membranes and airways, although, the symptoms can be delayed. The associated fumes can cause respiratory corrosion, pulmonary edema and often cardiac arrhythmia. Short exposures for 50 to 250 ppm concentrations are potentially life threatening
- **Flammable and explosive:** LIB waste and black mass contains binders that may be flammable or explosive. Furthermore, there are anecdotal accounts of spontaneous combustion and ‘small’ explosions; however, this requires verification by reliable evidence. HF is not flammable itself, but when it reacts with metals and decomposes it forms flammable hydrogen gas.
- **Respiratory:** Since black mass contains fine powder, this may lead to respiratory problems.
- **Electrostatic:** The electrostatic behaviour of black mass has been observed and reported during handling and transportation.

## Identification

HF is a weak acid in dilute solutions with initial signs of exposure being non-existent. As such, contact with HF can go unnoticed for long periods, enabling deeper penetration of fluorine and causing further damage to tissues and underlying bone. Exposure to concentrations of less than 20% can take up to 24 hours to generate visible symptoms. Initially, the skin swells, redness follows then white and yellow blisters are formed. HF is reactive with different materials, and its presence might be indicated by corroded glass bottles. HF can also be distinguished by its pungent smell when its concentration in air is greater than 0.04 – 0.13 ppm.

## Treatment

The treatment for HF exposures is to remove contaminated clothing and rinse the contaminated area with plenty of water. Calcium gluconate gel could be used if available. If accidentally swallowed, milk, chewable calcium carbonate tablets or milk of magnesia can be given, if the patient is still conscious. In the case of inhalation, the person should be moved to an open area with plenty of fresh air. Where the patient is not breathing, artificial respiration is necessary. Oxygen can be given if it is available. Immediate medical attention is required.

## Risk Mitigation, Handling, Storage and Transportation

Before the sampling, assaying or acceptance of black mass samples the corresponding material safety data sheet (MSDS) should be requested. Personal Protective Equipment (PPE) can protect from HF and associated fumes including; protective overalls, acid resistant boots, nitrile gloves, outer long sleeved gloves, gas masks or full face mask, working in a fume cupboard, with the correct rating and ventilated laboratory, if available. A personal HF detector alarm is recommended. Inspectors/chemists should be made aware of the potential for electrostatic behaviour and the level of risk hazards may be reduced by using non-electrostatic materials in the laboratory. The risk for fires and spontaneous combustion may be reduced by storing samples in isolation, in a fire proof container, regulating the atmosphere and implementing regular

inspection and thermal temperature monitoring. The development of storage, transportation and cleaning protocols are recommended including Standard Operating Procedures (SOP), Risk Assessments and Method Statements (RAMS) for each different type of black mass. Importantly, it should not be assumed that black mass from one location will behave identically to black mass samples from a different provenance or where there has been the 'blending' or mixing of different streams of LIB and black mass.

## SAMPLING AND SAMPLE PREPARATION AND Standard Operating Procedure (SOP)

### Description

The black mass from a European source was provided and originally described by the provider as 'cobalt nickel cake' and comprised a mixture of dark grey to black coloured fines along with fine metallic particles. It appeared in a dry and powder like condition and was described upon arrival as 'dirty and dusty' (Figure 4).



**Figure 4. Unprepared sample of black mass submitted for analysis (left). The diameter of the sample dish (right) is approximately 150 mm.**

### Packaging and Stowage

The black mass was found packed in 'big bags' on wooden pallets and stored under a roof covering. The bags were marked with the processing plants original number in red paint spray. Various markings were found on the bags and contained a big bag producer's label. After sampling, each big bag was sealed with a plastic tie and assigned a red seal with a six digit reference number.

### Weighing and Sealing

All bags were weighed by the client and a seal applied. Seals may deter casual attempts at tampering but will not prevent determined efforts to access the material.

### Bulk Sampling

All the big bags were opened, and the contents were penetrated vertically, twice, from the top to bottom using a sampling spear 1.2 m long and with a 40 mm diameter, and ensuring the spear reached the bottom of the bag (<sup>21</sup>Holmes 2004 and <sup>22</sup>Dehaine 2021). One increment was drawn in the middle section of the big bag and one on the side/corner of the big bag. Due care had been given to obtain a completely filled column of black mass each time. The tubes were removed vertically, and the samples were collected in a large, clean bucket. This ensured an equal amount of sample for each spear sample increment. Afterwards, the big bags were closed and sealed.

### Bulk Sample Preparation

All of the samples were combined in a single composite sample in a drum and reduced by Riffle Jones Splitter to obtain a sub-sample. The sample per container was subsequently split three times. The sub-sample was put in a bag, marked and underwent further sample preparation in the laboratory, including drying and preparation of the final analytic samples.

### Drying Moisture Determination

The sample were divided into two trays. The trays and samples were weighed on an electronic precision scale, before and after drying in an electric heated and thermostatically controlled drying oven until a constant weight was achieved. A moisture content was obtained by subtracting the difference. This gave an average moisture content for five container lots as; 7.8%, 7.95%, 11.67% and 9.57%.

### Comminution/Milling

The dried sample was milled/ground in a ring mill until it passed a 1 mm screen. The resulting fines were blended using

blending trays and a reduced sample was produced. This sample was further milled in a ring mill to pass a 0.112 mm screen. All oversized material was replaced into the ring mill and further milled with a nominal milling time until all the black mass passed the 112  $\mu\text{m}$  sieve. The pot, ball and rings were closed with a lid and pressed pneumatically to ensure it was secured. The mill vibrated at high-speed making the rings and ball spin in an ellipse. Once the milling was finished, the pot was removed and the contents emptied. For more resistant particles of black mass, a mill containing tungsten carbide was used. Inside this pot was a tungsten carbide ball within a housing. The pot, ball and rings were enclosed with a lid and pressed pneumatically to ensure it was sealed and secured.

### Blending

Following milling the black mass was blended for nominal time. The sample was collected in a plastic sample pot, closed with a screw lid. The sample pot was placed into the blender, the security cap was closed and blending sequence became initiated.

### Rotary Sample Division

The prepared sample comprised 100% fines in a dried state. The powder was mixed using blending trays and the blended material was tipped into a hopper feeding a small vibrating gutter, which slowly enabled the black mass to fall into a spinning riffle, feeding eight, glass, 200 ml bottles. These bottles were attached onto a carousel head, spinning at a constant speed. Once the sample was divided, the sample bottles were detached and the contents transferred into pre-labelled, small, sample bags. The sample bags were secured and packaged into paper envelopes, which were identified and labelled with relevant information and sealed with sealing tape. A prepared and unprepared sample underwent further preparation into resin blocks for phase characterisation.

## Methodology

The techniques used to analyse black mass were as follows:

- Visual examination and binocular microscopy.
- Manual scanning electron microscopy (SEM).
- Automated scanning electron microscopy with linked energy dispersive spectrometers (SEM-EDS) using advanced mineral identification and characterization system (AMICS).
- X-ray computed tomography (X-CT)
- Laser ablation inductively-coupled plasma mass spectrometry (LA-ICP-MS).

### Stage 1: Visual analysis

A preliminary inspection of the black mass sample was undertaken.

### Stage 2: Manual scanning electron microscopy (SEM).

Manual scanning electron microscopy (SEM) with linked energy dispersive spectrometers (EDS) provides information regarding the surface topography (shape, features, structures and textures) and composition of a sample by scanning its surface with a beam of electrons. As the electrons interact with atoms in the sample, electrons and X-rays are emitted, which are detected and processed by the instrument to produce an image and, with the addition of EDS, elemental composition information. Preliminary SEM images were collected using a TESCAN TIMA-X GMU field emission gun scanning electron microscope and a JEOL JSM-7100F field emission scanning electron microscope.

### Stage 3: Automated scanning electron microscopy with linked energy dispersive spectrometers (SEM-EDS) using advanced mineral identification and characterization system (AMICS).

Automated scanning electron microscopy with linked energy dispersive spectrometers (SEM-EDS) was carried out. The analysis provides rapid determination and quantification of the mineralogy/phase chemistry, particle size and shape of a variety of sample types. The technology was initially developed for use in the mining industry for the characterisation of mineral processing products such as feeds, concentrates and tailings and has been used in the analysis of a wide range of ore types (e.g., <sup>23</sup>Garg et al., 2017, <sup>24</sup>Jordens et al., 2016 and <sup>25</sup>Mackay et al., 2016). Data collection is operator independent, with the acquisition of very large data sets, hence the results are statistically reliable and provide highly reproducible analyses (e.g., <sup>26</sup>Pirrie et al., 2009). There are several main automated SEM-EDS analytical systems on the market, including QEMSCAN (Thermo-Fischer), Mineralogic (Zeiss), TIMA (Tescan) and AMICS (Bruker). Automated mineralogy methods typically involve imaging of samples with a scanning electron microscope (SEM) using the backscatter electron (BSE) signal (where the image brightness is proportional to the composition of the material) to guide the rapid acquisition of spot energy dispersive X-ray (EDS) spectra. These spectra, combined with the BSE image, are used to make a phase determination and this results in a detailed compositional image of each sample. The method is optimised for speed so that very large numbers of particles are measured during analysis. The resulting images provide data not only on the particle types and their modal proportions, but also a diverse range of textural attributes such as particle size and phase association.

Analysis was undertaken with a Hitachi SU3900 scanning electron microscope fitted with a single large area (60 mm<sup>2</sup>) Bruker silicon drift detector (SDD) energy dispersive spectrometer and running the AMICS automated mineralogy package. Beam conditions are optimised for analysis and therefore an accelerating voltage of 20 kV coupled with a beam current of approximately 15 nA were used.

The samples were measured using the same analytical parameters and with a segmented field image mode of analysis. This analytical mode subdivides the BSE image into the domains (segments) of similar brightness, which represent different mineral grains and then acquires a representative EDS X-ray spectrum from a point within the segment; the mineral identified

is then assigned to the entire segment. Measurements are optimised to highlight both textural and modal mineralogical information and so an effective image resolution of microns of 1.6  $\mu\text{m}$  was used. The EDS spectra acquired during the measurement are compared with a library of measured and synthetic standards and a phase identification is made on a closest match basis. Phases which are not represented in the standards list at the time of measurement are added either by acquiring reference spectra directly from the sample, or by creating a reference spectrum from the measurement itself. As the standards list can comprise hundreds of reference spectra, the data are grouped into a final, more manageable, reported list of phases. During AMICS analysis a full SEM-BSE map of the area imaged was also collected.

#### Stage 4: X-ray computed tomography (X-CT)

X-CT uses X-rays to obtain a series of two-dimensional (2D) radiographs of the object viewed from many different directions. This process is sometimes called a CT or X-CT scan. A computed reconstruction algorithm is then used to create a stack of cross-sectional slices from these 2D projections (radiographs) of the object. This provides a digital 3D greyscale representation (often referred to as a tomogram) of the internal structure of the object. This can be quantitatively analysed and virtually sliced in any direction or specific constituents can be digitally colour-coded, or rendered transparent, to visualize the 3D morphology (27Withers et al. 2021). A GE phoenix v|tome|x s X-ray micro computed tomography (micro-X-CT) device was used to image prepared and unprepared samples in resin blocks. They were imaged using an accelerating voltage of 100kV and a tube current of 50 mA, for a tube power of 5 W. Voxel resolution was 5  $\mu\text{m}$ .

#### Stage 5: Laser ablation inductively coupled mass spectrometry (LA-ICP-MS)

LA-ICP-MS analyses of the same black mass sample was carried out using a Nu AttoM SC-ICPMS (Nu Instruments Ltd., Wrexham, UK). The measurements were performed on 75 isotopes covering 68 elements at low resolution using the fast scanning mode. Data reduction was handled using excel spreadsheet, which allows the baseline subtraction, outliers removal, the integration of the signal over a selected time resolve area and the quantification using known concentrations of the NIST 612 standard.

## Results

### Visible analysis and manual SEM

The unprepared sample of black mass comprised a heterogeneous mixture of dark grey to black coloured fines with fine metallic particles (Figure 5). The bulk powdered sample was imaged using manual SEM and showed that the powders are composed of a wide range of particle sizes and shapes. Larger particles are commonly coated with finer particles, and the larger particles are commonly composite in nature (Figure 6).

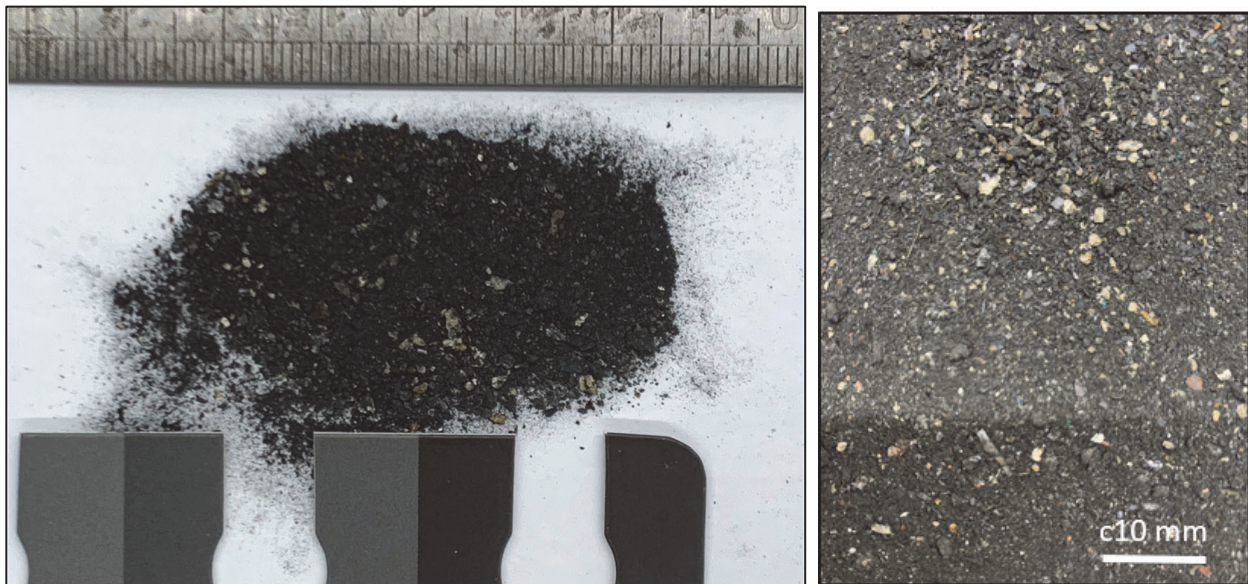

**Figure 5. Unprepared sample of black mass submitted for analysis (left), note the complex heterogeneous texture of the black mass (right).**

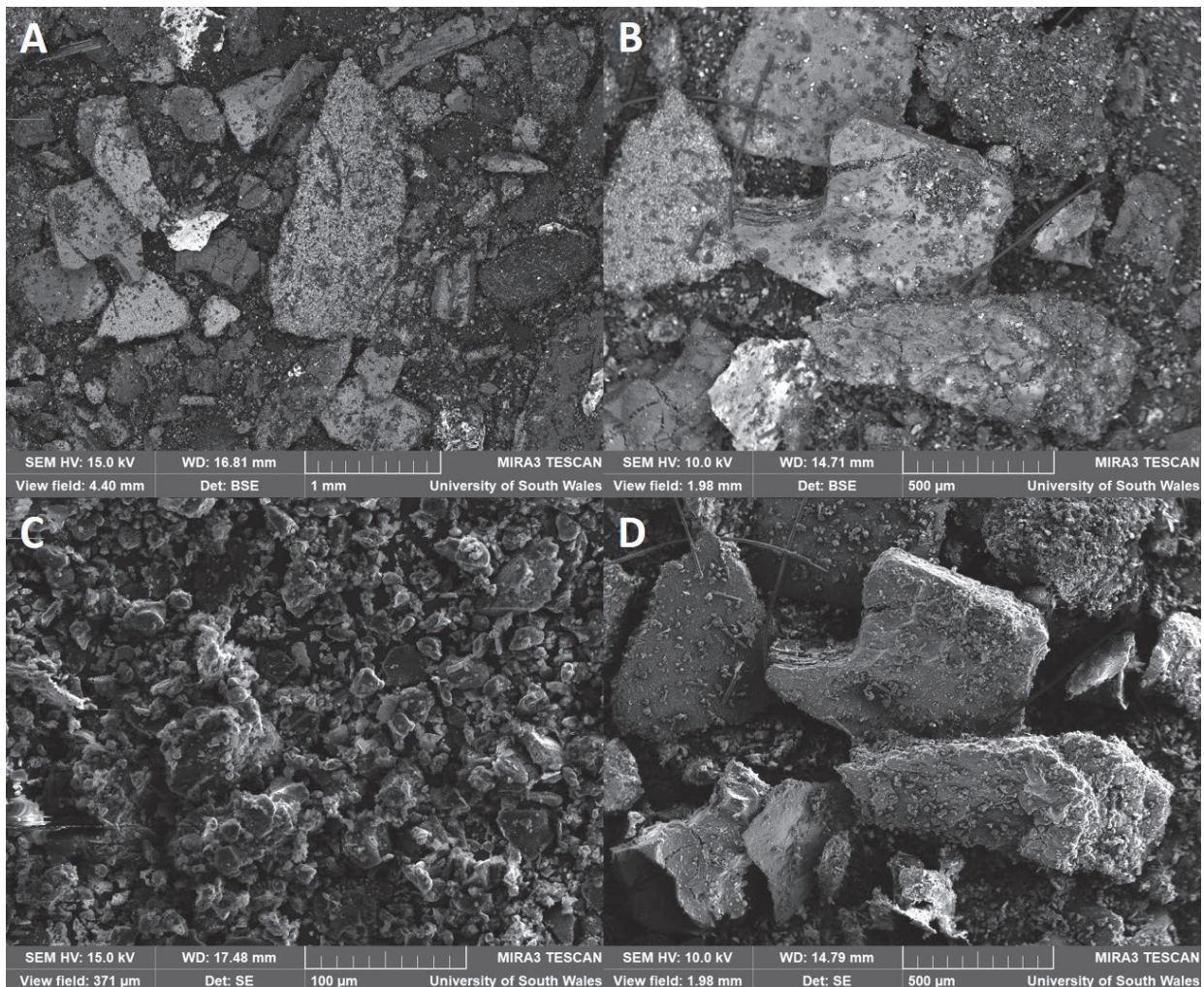

**Figure 6. Scanning electron microscope images of the black mass unprepared sample. (A, B) BSE imaging, (C, D) SE imaging. Note individual scale bars.**

#### Automated SEM-EDS

Both a prepared (powdered) and unprepared sample were measured three times using automated SEM-EDS analysis. The particles were assigned to 35 compositional groups based on the elemental composition. These compositional groups can be reclassified in terms of the likely attribution of the particles to the original battery components including: (a) graphite, (b) aluminium foil, (c) copper foil, and (d) lithium metal oxides. The lithium metal oxide category can be further divided into the five main cathode types, based on their phase chemistry: (i) NMC (LiNiMnCo oxides), (ii) LCO (LiCo oxides), (iii) LM(N)O (LiMn(Ni) oxides), (iv) LFP (LiFe phosphates) and (v) NCA (LiNiCoAl oxides). Within the data there are also; (1) particles currently assigned to mineralogical categories; these may be derived from the batteries or are cross contamination with environmental materials, and (2) metal phases, the attribution of which is currently unclear, although they may relate to parts of the battery casing or cross-contamination from other sources in the waste processing stream. Note that SEM-EDS analysis cannot determine the presence of Li, but the overall particle chemistry allows the particle types to be assigned.

The automated mineralogy images allow the particle types, as seen in the 2D measured sections to be visualised. The majority of the larger particles are complex mixed phases, often with the Al foils coated with the different Li metal oxide compounds. The Cu foil is predominantly as a separate phase, with an appearance in the 2D faces as similar to a Cu wire (Figure 7). In reality as shown by the 3D X-CT imaging these are in fact thin and complexly folded Cu sheets (Figure 8). Texturally the particles are complex, but the imaging allows them to be distinguished. In the Al foils with Li metal oxide coatings, the organic binding agents appear dark grey in the BSE images and are not characterised in the automated SEM-EDS analysis.

#### Micro X-CT

On completion of the interactive SEM-EDS analysis the same unprepared and prepared sample blocks were imaged using micro X-CT scanning. The aim of the micro X-CT was to image the 3D form of the particles; the automated SEM-EDS and interactive SEM-EDS data are all derived from the analysis of the 2D polished face of the analysed sample. Micro X-CT analysis allows the visualisation of the 3D particle form and can be cross-correlated with the automated SEM-EDS phase attribution carried out on a 2D surface (Figure 8).

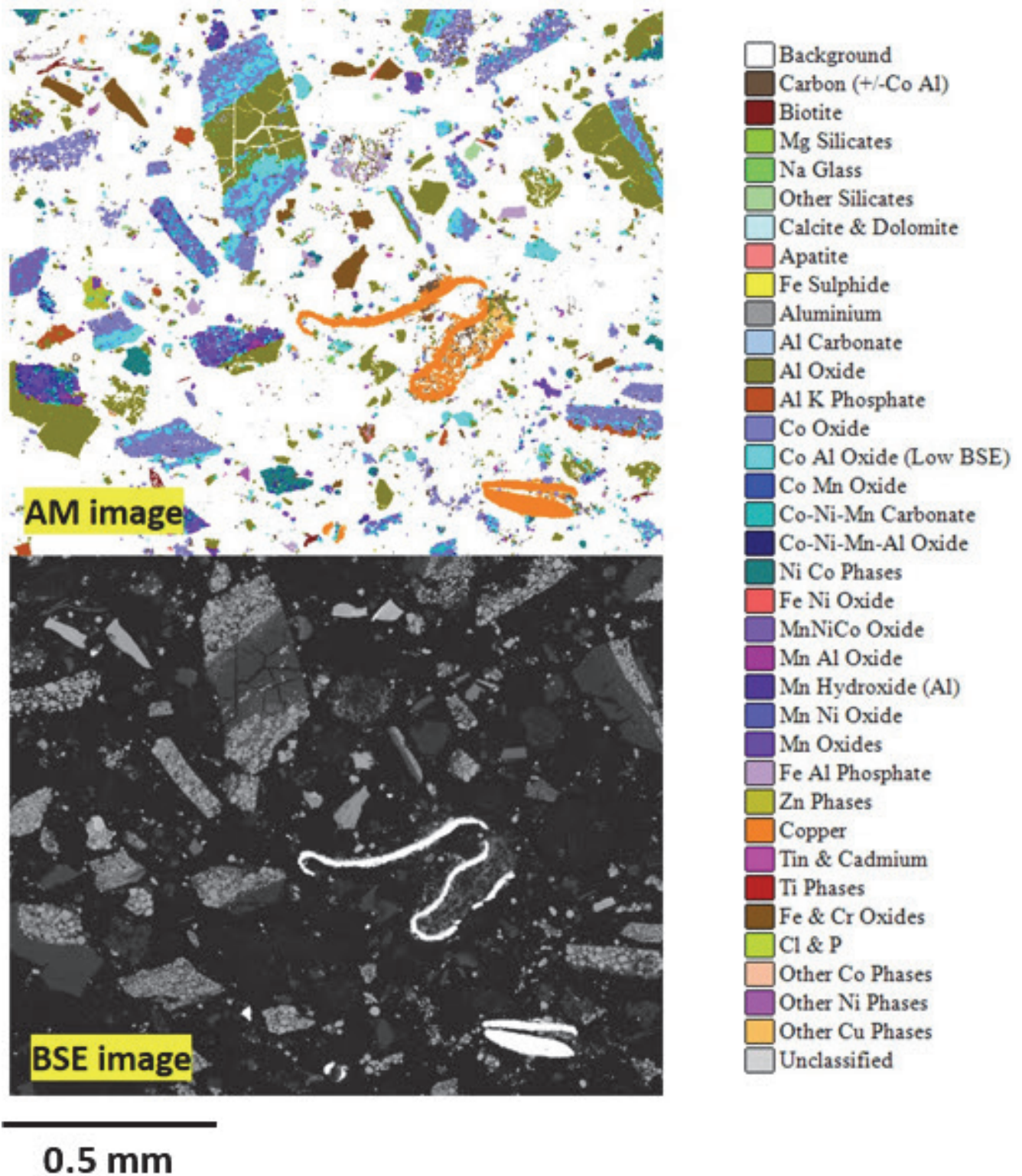
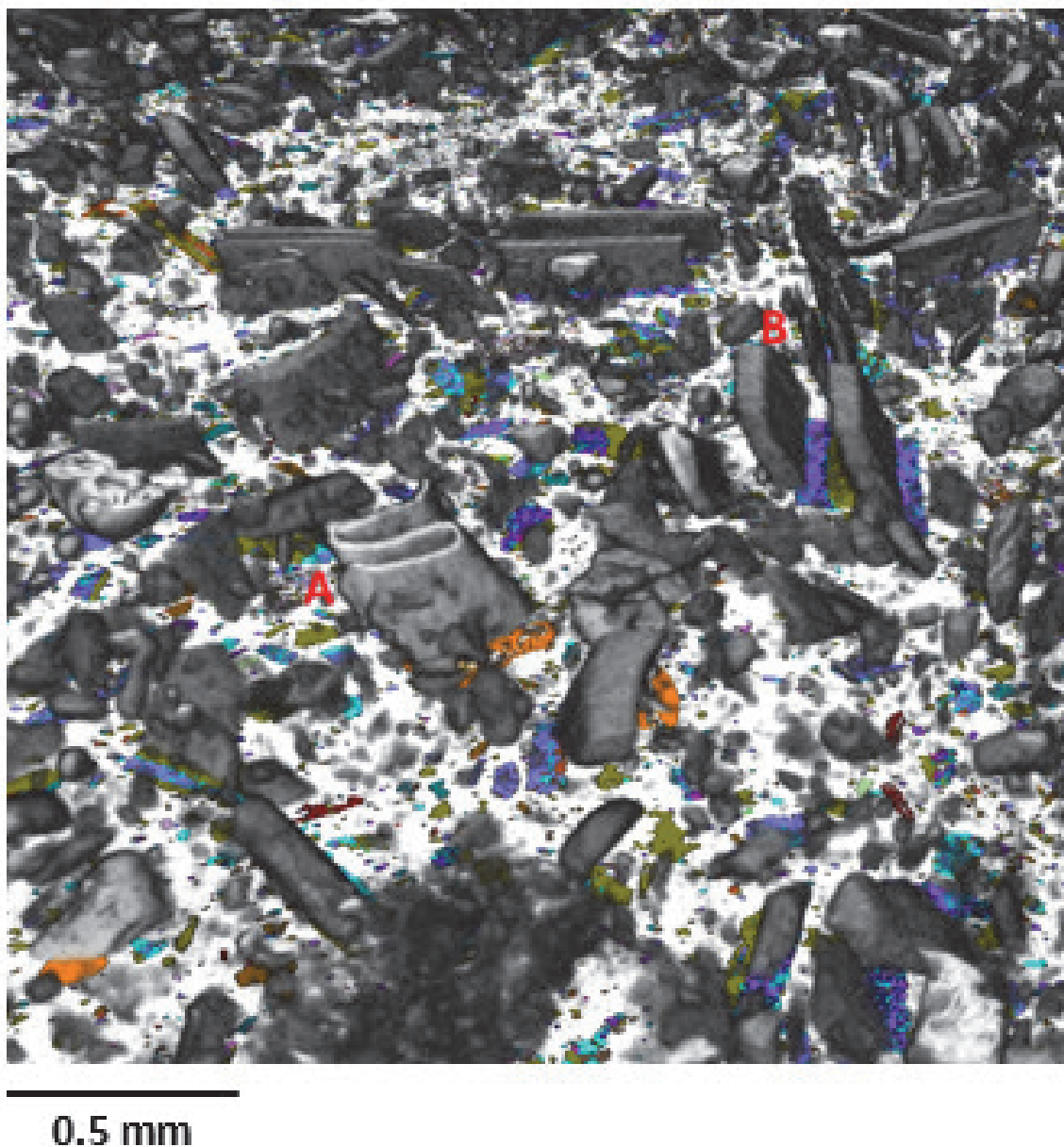

Figure 7. Automated mineralogy (AM) and SEM-BSE images for a sample of black mass. The bright phase in the SEM-BSE image is Cu foil, which in 2D sections looks like folded wire.





**Figure 8. Enlarged micro X-CT image, from a video, showing form of (A) the Cu foil particles in 3D and (B) the form of the cathode/Al foil components.**

#### LA-ICP-MS

On completion of the interactive micro X-CT, selected phases were analysed for minor and trace elements using laser ablation inductively-coupled mass spectrometry (LA-ICP-MS). Sixty-eight elements including Li were measured (Figure 9). The LA-ICP-MS analysis determined the Li content within the characterised particle. LA-ICP-MS analyses of the 7 spots indicated on Figure 9 are shown in Table 1 for Li, Mn, Ni and Cu. The analysis demonstrates that the methodology can detect and quantify the Li abundance confirming the automated SEM-EDS phase characterisation.

**Table 1. LA-ICP-MS spot analysis of the cathode particle, units in ppm in Figure 9.**

	Spot 2.1	Spot 2.2	Spot 2.3	Spot 2.4	Spot 2.5	Spot 2.6	Spot 2.7
Number of analysis	4	5	6	7	8	9	10
Li	137273	146949	117094	144534	130095	136261	132580
Mn	190843	190577	187836	194614	178263	198542	204555
Ni	189918	198121	214525	216398	206958	206486	191140
Cu	11478	23029	12929	15113	11103	25873	4507

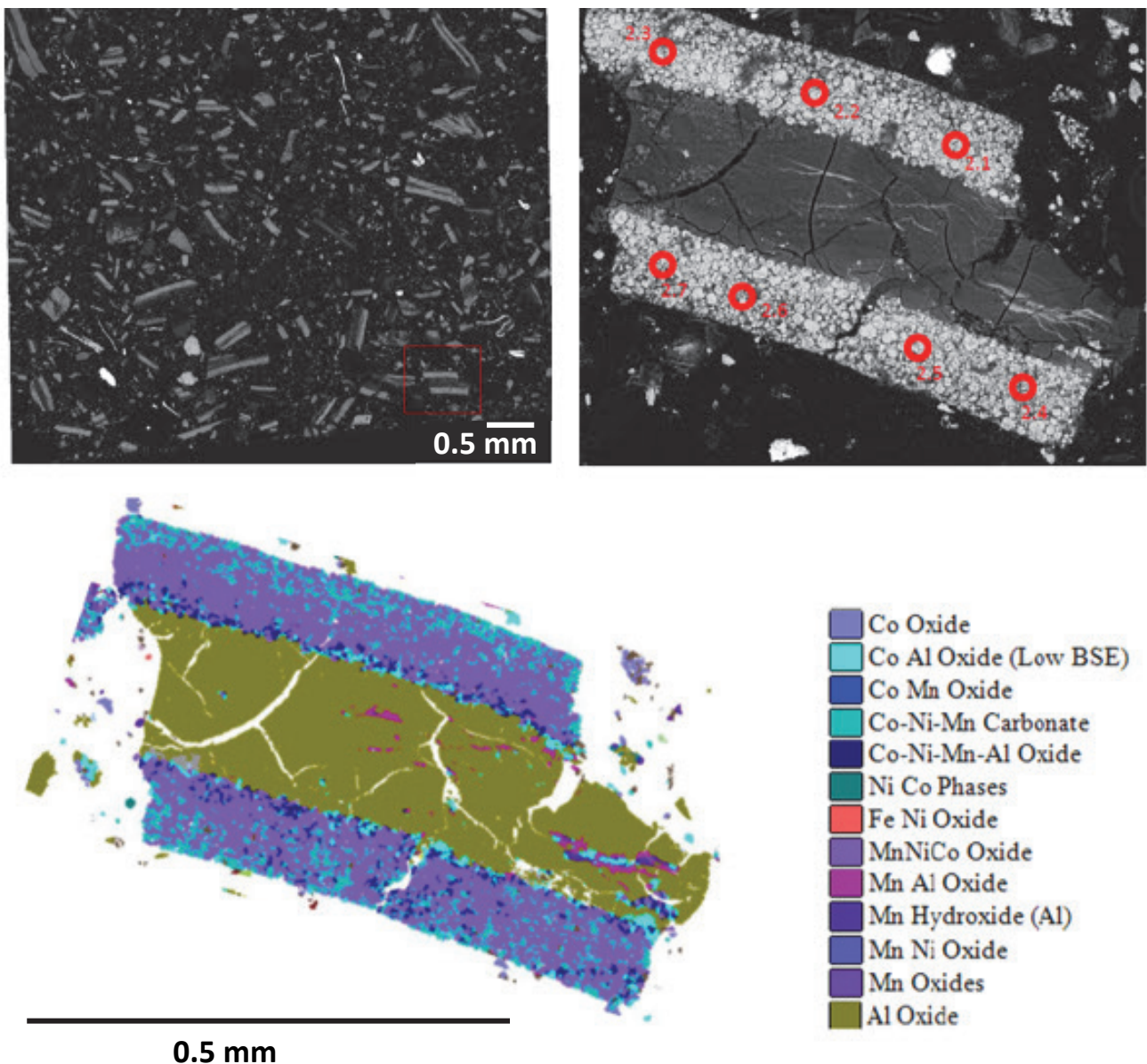

**Figure 9.** SEM-BSE image of the analysed sample; note the particle highlighted in the red box. Same particle, attributed to a cathode LMO, shown under SEM-BSE with the location of the laser ablation analysis (red circles) indicated and also the AMICS automated SEM-EDS particle mapping.

## Conclusions

The results of this investigation to characterise a sample of black mass are as follows:

- Automated SEM-EDS can not only characterise and quantify the phases present, but also the phase chemistry allows the particle types to be assigned back to the primary battery components. However, some phases identified are at present not attributed back to the original components and further work is needed to refine the compositional groups, with the analysis of additional samples.
- Interactive SEM-EDS analysis also demonstrated that there is more detailed higher resolution chemical variability within the individual particle categories.
- Micro X-CT imaging has demonstrated the 3D form of the particles within the analysed sample volume. The 3D particle shape is potentially significant in terms of how the material will behave during subsequent grinding and chemical analysis.
- Neither automated nor manual interactive analysis can determine the presence/abundance of the light element, Li.
- LA-ICP-MS was successful in detecting and quantifying the presence of potentially strategically and economically important metals such as Li.
- Phase characterisation prior to processing is of value to potentially; (a) assist development of a suitable sampling strategy, (b) assist in determining the optimal processing route, (c) determine the presence of payable phases, (d) identify phases which may hinder metal recovery or may be regarded as penalty components, (e) aid in the development of laboratory assay procedures, and (f) assist in the identification, management and mitigation of hazards and their associated levels of risk.

- Given the different feeds within a recycling plant leading to the formation of the black mass powder for subsequent processing, such powders are likely to be variable in terms of their composition and particle characteristics.

## References

- Chen, M., Zheng, Z., Wang, Q., Zhang, Y., Ma, X., Chen, C., Xu, D., Liu, J., Gionet, P., O'Connor, I., Pinnell, L., Wang, J., Gratz, E., Arsenault, R. and Wang, Y. 2019. Closed loop recycling of electric vehicle batteries to enable ultrahigh quality cathode powder. *Scientific Reports*, **9**, 1654, <https://doi.org/10.1038/S41598-018-38238-3>.
- Harper, G., Sommerville, R., Kendrick, E., Driscoll, L., Slater, P., Stolkin, R., Walton, A., Christensen, P., Heidrich, O., Lambert, S., Abbott, A., Ryder, K., Gaines, L. & Anderson, P. 2019. Recycling lithium-ion batteries from electric vehicles. *Nature*, **575**, 75-86.
- Or, T., Gourley, S.W.D., Kaliyappan, K., Yu, A. and Chen, Z. 2019. Recycling of mixed cathode lithium-ion batteries for electric vehicles: current status and future outlook. *Carbon Energy*, **2**, 6-43.
- Brückner, L., Frank, J. and Elwert, T. 2020. Industrial Recycling of Lithium-Ion Batteries. A Critical Review of Metallurgical Process Routes. *Metals*, **10**, 1107. <https://doi:10.3390/met10081107>.
- Vanderbruggen, A., Gugala, E., Blannin, R., Backmann, K., Serna-Guerrero, R. and Rudolph, M. 2021. Automated mineralogy as a novel approach for the compositional and textural characterization of spent lithium-ion batteries. *Minerals Engineering*, **169**, 106924.
- Werner, D., Peuker, U.A. & Mütze, T. 2020. Recycling chain for spent lithium-ion batteries. *Metals*, **10**, 316, <https://doi.org/10.3390/met10030316>.
- Barik, S.P., Prabakaran, G. & Kumar, L. 2017. Leaching and separation of Co and Mn from electrode materials of spent lithium-ion batteries using hydrochloric acid: Laboratory and pilot scale study. *Journal of Cleaner Production*, **147**, 37-43.
- Diekmann, J., Hanisch, C., Frobose, L., Schaliche, G., Loellhoeffel, T., Folster, A.-S. and Kwade, A. 2017. Ecological recycling of lithium-ion batteries from electric vehicles with focus on mechanical processes. *Journal of the Electrochemical Society*, **164**, A6184-A6191.
- Friedrich, B. & Schwich, L. 2020. New science-based concepts for increased efficiency in battery recycling. *Metals*, **11**, 533, <https://doi.org/10.3390/met11040533>.
- Liu, J., Wang, H., Hu, T., Bai, X., Wang, S., Xie, W., Hao, J. and He, Y. 2020. Recovery of LiCoO<sub>2</sub> and graphite from spent lithium-ion batteries by cryogenic grinding and froth flotation. *Minerals Engineering*, **148**, 106223.
- Lu, J., Wu, T. & Amine, and 2017. Start-of-the-art characterization techniques for advanced lithium-ion batteries. *Nature Energy*, **2**, 17011, <https://doi.org/10.1038/nenergy2017.11>.
- Pinegar, H. and Smith, Y.R. 2019. End-of-life lithium-ion battery component mechanical liberation and separation. *JOM*, **71(12)**, 4447-4456.
- Ruismaki, R., Rinne, T., Dańczak, A., Taskinen, P., Serna-Guerreo, R. and Jokilaakso, A. 2020. Integrating flotation and pyrometallurgy for recovering graphite and valuable metals from battery scrap. *Metals*, **10**, 680, <https://doi.org/10.3390/met10050680>.
- Schwich, L., Schubert, T. and Friedrich, B. 2021. Early-stage recovery of lithium from tailored thermal conditioned black mass part 1: Mobilizing lithium via supercritical CO<sub>2</sub>-carbonation. *Metals*, **11**, 177, <https://doi.org/10.3390/met11020177>.
- Widijatmoko, S.D., Gu, F., Wang, Z. and Hall, P. 2020. Selective liberation in dry milled spent lithium-ion batteries. *Sustainable Materials and Technologies*, **23**, e00134.
- Zielinski, M., Cassayre, L., Floquet, P., Macouin, M., Destrac, P., Coppey, N., Foulet, C. and Biscans, B. 2020. A multi-analytical methodology for the characterisation of industrial samples of spent Ni-MH battery powders. *Waste Management*, **118**, 677-687.
- Otsuki, A., Mensbrugge, L. De La, King, A., Serranti, S., Fiore, L. and Bonifazi, G. 2020. Non-destructive characterization of mechanically processed waste printed circuit boards – particle liberation analysis. *Waste Management*, **102**, 510-519.
- Donnelly, L.J., Pirrie, D., Power, M., Corfe, I. Kuva, J., Lukkari, S., Lahaye, and Butcher. A. 2021a. The Phase Characteristics and Textural Variability of Black Mass. *Abstract for 26th International Congress for Battery Recycling, ICBR 2021*, Onsite and Virtual, 22-24 September 2021m Geneva, Switzerland.
- Donnelly, L.J., Pirrie, D., Corfe, I., Michaux, S. P., and Butcher A. 2021b. The Phase Characterization of Black Mass and its Commercial Implications in the Circular Economy. *20th International Automobile Recycling Congress IARC 2021*, 23-25 June 2021 Geneva, Switzerland.
- Nissi, J. 2019. 2019. *Development of Safety Protocols in Aalto University LIB Recycling Laboratory. Master's Programme in Chemical, Biochemical and Materials Engineering, Major in Sustainable Metals Processing*. Aalto University, School of Chemical Engineering, Finland.
- R.J. Holmes, "Correct sampling and measurement—the foundation of accurate metallurgical accounting", *Chemometrics and Intelligent Laboratory Systems* **74(1)**, 71 2004. doi: <http://dx.doi.org/10.1016/j.chemolab.2004.03.019>
- Dehaine, Q. 2021. Loosen the TOS stipulations and face the economic consequences. *Spectroscopy Europe*, **33(7)**, 32. doi: <http://dx.doi.org/10.1255/sew.2021.a37>
- Garg, S., Papangelakis, V., Edwards, E. and Mahadevan, R. 2017. Application of a selective dissolution protocol to quantify the terminal dissolution extents of pyrrhotite and pentlandite from pyrrhotite tailings. *International Journal of Mineral Processing*, **158**, 27-34.
- Jordens, A., Marion, C., Grammatikopoulos, T. and Waters, K.E. 2016. Understanding the effect of mineralogy on

- muscovite flotation using QEMSCAN. *International Journal of Mineral Processing*, **155**, 6-12.
25. Mackay, D.A.R., Simnadl, G.J., Ma, W., Redfearn, M. and Gravel, J. 2016. Indicator mineral-based exploration for carbonatites and related specialty metal deposits – A QEMSCAN orientation survey, British Columbia, Canada. *Journal of Geochemical Exploration*, **165**, 159-173.
  26. Pirrie, D., Power, M.R., Rollinson, G.K., Wiltshire, P.E.J., Newberry, J. and Campbell, H.E. 2009. Automated SEM-EDS (QEMSCAN) mineral analysis in forensic soil investigations; testing instrumental variability. In: Ritz, K., Dawson, L. & Miller, D. (eds) *Criminal and Environmental Soil Forensics*. Springer, 411-430.
  27. Withers, P.J., Bouman, C., Carmignato, S., Cnudde, V., Grimaldi, D., Hagen, C.K., Maire, E., Manley, M., Du Plessis, A. and Stock, S.R. 2021. X-Ray Computed Tomography. *Nature Reviews Methods Primer*, <https://doi.org/10.1038/s43586-021-00015-4>.



## Multivariate methods for improved geometallurgy sampling

Q. Dehaine<sup>a</sup> and K.H. Esbensen<sup>b</sup>

<sup>a</sup>Geological Survey of Finland (GTK), Circular Economy Solutions Unit, Vuorimiehentie 2, 02151 Espoo, Finland.

E-mail: [quentin.dehaine@gtk.fi](mailto:quentin.dehaine@gtk.fi)

<sup>b</sup>KHE Consulting, Copenhagen, Denmark. [khe.consult@gmail.com](mailto:khe.consult@gmail.com)

**Geometallurgy is at the core of life-of-mine value chain optimisation, with the aim of integrating geoscientific disciplines along with mining engineering and minerals processing. The objective is to link comprehensive geological, geochemical, mineralogical and geotechnical information with metallurgical and mining variability - based on spatially distributed samples. The spatial coverage is a crucial element in this process. Geometallurgy samples are used for metallurgical testing in the service of plant and process design and optimisation. To avoid discrepancies between the expected and actual process performance, geometallurgical test work must be based on *representative samples* collected and processed in compliance with the Theory of Sampling (TOS). However, even if samples are initially collected to populate a multivariate block model, most of TOS' recommendations for estimating sampling protocols and sample representativeness is *univariate*. While the univariate approach is sufficient when a sample must be representative for one property only e.g., for grade estimation, it fails to properly qualify representativeness of a sample which must be representative for multiple properties such as for geometallurgical purposes. Indeed, a geometallurgy sample is considered representative *sensu stricto* only if its metallurgical behaviour is representative of that of the full zone of the orebody it represents. This can only be achieved if-and-when geo-metallurgical samples are representative for the full set of ore properties that influence process performance. The critical success factor of multivariate representativeness can be assessed using multivariate approaches, such as the multi-variogram, which allow us to summarise the global variability of multiple properties into a single characteristic function. This approach could be optimised by using downstream results from geo-metallurgical process modelling, to select or weight, the individual property contributions to the multi-variogram according to their importance, thereby allowing to optimise a specific geometallurgical sampling procedure in terms of sampling mode, sampling frequency and the number of increments involved according to the overall process performance.**

### Introduction

The Theory of Sampling (TOS) is inextricably linked to the minerals and mining industry as the source of inspiration for Gy's sampling theory<sup>1</sup>. In the mining, and many other industries, technical and business decisions, as well as project evaluations are heavily dependent on representative sample collection along the entire mine value chain from exploration to closure<sup>2,3</sup>. The optimisation of this value chain over the life-of-mine (LOM) is enabled by the application of geometallurgy<sup>4,5</sup>. Geometallurgy - often reduced to a combination of geology and mineral processing to document the empirical variability within an orebody and to quantify the impact of ore properties onto process performance - is a multi-disciplinary holistic approach aiming at the best possible use of mineral resources in terms of energy and resource efficiency, environmental impact and - of course - revenues, by integrating all relevant geoscientific and engineering disciplines<sup>5,6</sup>. It involves understanding and measuring geological, mineralogical and metallurgical ore properties to generate a database to be integrated into a spatial predictive model for mining operation and mineral processing, as well as mine planning and financial analysis of future or existing mines<sup>7,8</sup>. The aims are to improve resource management, metallurgical processes performance, and ultimately the net present value (NPV) of a mining project, while reducing operational, technical and environmental risks<sup>4,6,9</sup>, all aligned with the two UN world goals featured as *lead-motifs* for this WCSB10.

Traditionally, *composite samples* that are reported to be 'representative' of the orebody are collected based on grade and spatial location for metallurgical test work yielding metallurgical parameters (e.g., throughput, recovery) used to design process plant<sup>10</sup>. But in some cases, after the first years of operation, the commissioned process plant can be found not to be performing as planned, which translates into an overrun of the Capital Expenditure (CAPEX) or the money required to build and commission a mining operation run out before the point where it can start producing a saleable concentrate<sup>9</sup>. The most often identified reason is that this approach does not account well enough for spatial variability within the orebody, which translates into unnecessary processing variability over time due to insufficient and unrepresentative material characterisation which has led to inappropriate initial test work. Geometallurgy aims to resolve such unwanted variability, but still requires high-quality metallurgical test work, most emphatically based on representative samples collected and processed within the framework of TOS<sup>11</sup>.

### Sampling for geometallurgy

#### Sample Types

Geometallurgy heavily relies on sampling of different sample types, situations, size and scales each with distinct objectives and requirements. In practice four different sampling procedures can be differentiated<sup>12</sup>:

- *In-situ* information which is extracted virtually/digitally from the orebody, for example in the form of geophysical data, downhole measurements such as density, conductivity, or assays.
- *Ex-situ* physical sampling extracted from the orebody, e.g., drill cores, cuttings, or chips.
- *Process sampling* when samples are extracted from a moving stream of ore, regarded as a 1D lot, in the mineral processing

plant. This can be particulate and solid material extracted from a conveyor belt (run-of-mill, gravel, feed, etc.) or pipelines (slurries, process water, etc.).

- *In-line sampling* (in-line sensor measurements) collected from moving streams (belts, pipes, froth product/flotation stations). This includes a wide variety of analytical technologies collectively known as PAT (Process Analytical Technologies) e.g., Raman, IR, XRF, NAA, Camera-based image analysis)<sup>13</sup>.

In terms of dimensionality, these sample types can be grouped in two categories: (i) spatially distributed samples (*i.e.*, *in-situ* and *ex-situ* samples) and temporally distributed samples (*i.e.*, process samples and in-line samples). Both categories are critical for the success of the geometallurgy approach, even if spatially distributed samples remain a prerequisite to build the 3D geometallurgy model. The importance of each sample type also varies depending on the project status. Spatially distributed samples are critical at the early stage of the project for *strategic geometallurgy* whereas process samples and data are more critical at the operating stage for *tactical geometallurgy*<sup>14</sup>. These two levels of implementation of geometallurgy differ by the required granularity and the decision-making time horizons: strategic geometallurgy focuses on the whole orebody and long-term LOM, whereas tactical geometallurgy has a short- to medium-term operational focus during mining<sup>14</sup>.

### Sample scale and size

In terms of scale and size, the geometallurgy approach usually employs small spatially distributed samples to perform lab-scale tests which are used as proxies for process parameters which are then compared with larger metallurgical samples to establish correlations prior to modelling<sup>5</sup>. Small process samples are also collected for process control, reconciliation or development<sup>15</sup>. Even larger bulk metallurgical samples, representative of both grade, spatial and population distributions within the ore zone, are collected for pilot testing and plant design<sup>16</sup>.

### Number of samples

Some generalised recommendations exist for numbers of samples per relevantly identified geometallurgy domains or ore types, but this approach most often requires proper analysis on a case-by-case basis, especially as concerns how to sample across intersections<sup>10,17</sup>. Factors like *in-situ* heterogeneity (e.g., grade, alteration, mineralogy and texture), orebody size and number of domains must be taken into considerations and samples evenly distributed<sup>10</sup>. The number of samples required to forecast different geometallurgy parameters varies significantly depending on the targeted parameters (e.g., mass pull, recovery rates, concentrate quality) and the level of reliability required<sup>17</sup>. In practice, the data spacing required is that of an Indicated/Measured resource with the drill grid defined via the use of the semi-variogram (referred to as variogram). In most cases however, such variographic analysis is based on univariate grade or elemental assay only<sup>10,18</sup>.

### Defining a representative geometallurgy sample

A sample can be described as being representative when it results in acceptable levels of bias and precision<sup>19</sup>. Hence, besides sample type, size and number, one of the main differences between sampling for geometallurgy compared to traditional sampling programs in the minerals and mining industry, is that samples must be representative for several properties as opposed to one parameter only as is tradition (*i.e.*, the grade)<sup>20</sup>. Indeed, by definition geometallurgy is multivariate (multi-component) as it aims at predicting and quantifying the full multi-component metallurgical performance based on geological, geochemical, textural and mineralogical ore characteristics, which is hardly optimal when considering only one analyte<sup>21</sup>. Indeed geo-metallurgical samples are always collected with the purpose of acquiring multivariate data through a comprehensive set of measurements (e.g., chemical or mineralogical assay, hardness) or testing (e.g., Bond Work index, kinetic flotation test, leaching test)<sup>10,18</sup>. The resulting multivariate dataset is then either integrated into a 3D block model, when dealing with drill core samples for instance, or with a process model, when dealing with process sampling. In either case, the outcome of the model, such as the mining block model value or the simulated process performance, is directly dependant on the quality of the input variables of which there are always *many*. Thus, the issue of multivariate representativeness is at the core of geo-metallurgical sampling. This is especially relevant concerning optimal definition of operative Decision Units (DU), see below. It's fair to say that this issue is a work in progress, very challenging and therefore very interesting.

### Spatial coverage – inferential statistics to the rescue

The overarching problem in geometallurgy is how to design a sampling campaign that guarantees the necessary-and-sufficient *spatial coverage* of the entire mineralisation or orebody? Many of the elements involved in a general solution are known to the geometallurgical realm, but the critical success factor will always be **how to** sample a 3-D body, or a 1-D drill core (if you can sample a 1-D core adequately, you can sample any number, going a long way towards a full 3-D body). Though always strongly dependent upon the specific orebody, the general problem is that one cannot sample the entire (1-D, 3-D) body, however desirable *would be* full sampling, full coverage, full certainty, full confidence in the ensuing test work. One always must *sample* in time (dynamic lots) and/or space (stationary lots), e.g., what fraction of the possible total number of samples that *could* be extracted in a lot, are needed to make a satisfactory geometallurgical characterisation with respect to a desired confidence and reliability? For example, it is up to project management to decide *a priori* its desired confidence level (X %) that no more than Y % of samples *may* fail a specific quality criterion, e.g., may exceed an analyte or component Z maximum concentration threshold.

Bringing in a modicum of statistical rigor, prior to any sampling event, an operative Decision Unit (DU) must be established; the DU is the material volume that an analytical result makes inference to. A lot is a collection (population) of individual DUs that will be treated as a whole (accepted or rejected), depending on the analytical results for individual Decision Units. The application of the Theory of Sampling (TOS) is critical for sampling the material within a Decision Unit. However, knowledge of the analytical

concentration of interest *within* a Decision Unit will not necessarily provide information on *unsampled* Decision Units, especially for heterogenous (or very heterogeneous) lots like many mineralisations and orebodies, where DUs can be of very dissimilar characteristics. The very geometallurgy variability issue spills over into the critical issue of case-relevant DU definition. While this issue undoubtedly looms large in many geo-metallurgical projects, there are no universally applicable rules at this time.

In such geo-metallurgical cases where every DU cannot possibly be sampled but where the spatial coverage demand is always marked, application of *non-parametric statistics* can be used to make inference *from* sampled Decision Units *to* Decision Units that are *not* sampled. The combination of the TOS for sampling of individual Decision Units along with non-parametric statistics offers the best possible inference for situations where there are more Decision Units than can practically be sampled physically. Recently Ramsey and Esbensen (2022) presented this combined TOS-statistics sampling scope in a fully worked-out framework, ready to be taken into the sampling realm, including geometallurgy<sup>22</sup>; the title tells it all: “Inferential statistical sampling of hyper-heterogeneous lots with hidden structure: the importance of proper Decision Unit definition”.

## Theory of Sampling (TOS) and variographic analysis

### TOS and univariate variographic analysis

Introducing TOS and variographic analysis in the context of this paper for the World Conference of Sampling and Blending, WCSB10) must surely be one of the most unnecessary tasks conceivable. Suffice to direct attention to no less than three recent textbooks<sup>23–25</sup>, all three conveniently presented in a comparison format TOS Forum, issue 10 (2020)<sup>26</sup>. Variographic data modelling has been presented in very many contexts (not least in the three textbooks referred to above), but also specifically for the present audience in Minnitt & Esbensen 2018<sup>27</sup> and in Pitard and Minnitt 2008<sup>28</sup>. The reader will find a plethora of further references and scores of application examples in these five exposés.

For the present scope suffice to point to the imperative of representative sampling procedures overall, whether directed at stationary or moving (process) lots. On this basis, a variographic data model allows powerful insight into how well a particular sampling system/procedure/solution has succeeded in eliminating and/or reducing maximally all detrimental Incorrect Sampling Errors (ISE), Correct Sampling Errors (CSE) as well as the Total Analytical Error (TAE) effects on the analytical results. Variographic data modelling is enormously powerful and comprehensive – indeed it has only one negative to it, it is manifestly only univariate. Only!

### TOS and multivariate variographic analysis

Although, the need for TOS to enter the multivariate realm was already exposed at WCSB2<sup>29</sup>, application of TOS so far have been almost exclusively been univariate<sup>11</sup>. However perfunctory multivariate approaches are well-known in two disciplines related to geology, geochemistry, mining, mineral processing *a.o.*, *geostatistics* and *chemometrics*, and it is from these disciplines that two solutions have recently been proposed to integrate the multivariate nature of heterogeneity with TOS.

An initial solution derived from the world of chemometrics is to reduce the dimensionality of the dataset through application of Principal Component Analysis (PCA) and to model a variogram on the *scores* of the first few principal components<sup>30</sup>. This approach, referred to as *variogram (t-score)*, offer the advantage of combining a variable reduction procedure that describes the correlation between all the variables involved in the multivariate data and which highlights the hidden structures and spatial (or temporal) patterns through variables grouping (the PCA) to a procedure that characterises autocorrelations within an ordered dataset, the variogram<sup>31</sup>. Alternatively, a ‘reverse’ approach, referred to as *PCA (variograms)*, consists in applying PCA analysis on individual variograms for each variable, which allows to conduct similar data analytical interpretations and results, but with the benefits of knowing the individual variability characteristics of each individual variables<sup>32,33</sup>. Application of this complementary ‘dual’ approach has to be guided by the specifics of a particular context<sup>22–25</sup>.

Another approach, derived from the world of geostatistics, which recently was introduced to the realm of TOS (WCSB7) is the multivariate variogram, also referred to *multivariogram*<sup>34</sup>. In multivariate variographics, each measured variable  $x_i$  (*e.g.*, chemical analytes, physical properties) is considered collectively as one multivariate dataset and combined in one vector,  $X$ , with  $p$  elements (the  $p$  individual variables). The multivariogram  $V_j$  of  $X$  is then calculated using the master equation<sup>20</sup>:

$$V_j(X) = \frac{1}{2(N-j)} \sum_i^{N-j} (X_i - X_{i+j})M(X_i - X_{i+j})^t, \quad j = 1, \dots, N/2 \quad (1)$$

(subscript  $t$  is the transpose operator),  $N$  is the total number of increments (*i.e.*, samples) collected,  $j$  the process lag parameter, and  $M$  a metric (positive definite  $p \times p$  matrix) defined as the inverse of the variance-covariance matrix of  $X$ .  $M$  corresponds to the Mahalanobis distance (MD), which defines the “distances” between the units, *i.e.*, the relationship between the variables, takes into account the correlation in the data<sup>35,36</sup> and is considered to be adapted to multivariate variography as opposed to the Euclidean metric for which the multivariogram would only be the *sum* of the univariate variogram of each individual variable<sup>20,34</sup>. The multivariogram can thus be used to summarize the overall spatial (or temporal) variability of data from a set of variables in one structural function and thus highlight the spatial (or temporal) structures that are *common* to these variables<sup>20</sup>.

## The added value of multivariate variographic approaches for geometallurgy sampling

Alas, there has been limited amounts of publication on multivariate variographic analysis for geometallurgy sampling, most of them focusing on process sampling. One of the first study on the topic, applied to industrial residue stream considered for by-product



metal recovery<sup>37</sup>, applied and combined the above-mentioned multivariate approaches on a set of 8 variables (Figure 1). These variables reflect critical properties of the residue with regards to the design of a by-product recovery process<sup>38,39</sup> and are also used in the establishment of a geometallurgy model<sup>40</sup>. The use of the multivariogram allowed to assess the true global variance of the sampling error and thus design the optimal sampling protocol with respect to all the variables of interest. However, the estimated global variance with this approach is very high. This means that designing a sampling campaign, and defining the number of increments to be sampled, based on the multivariogram would lead to (unrealistically) large number of increments to be sampled to obtain a reasonable sampling variation. To overcome this issue the authors proposed to combine the multivariogram with PCA analysis by computing the multivariogram of the first PCs' scores. This allows to reduce the influence of noisy data and thus reduces the overall sampling variance.

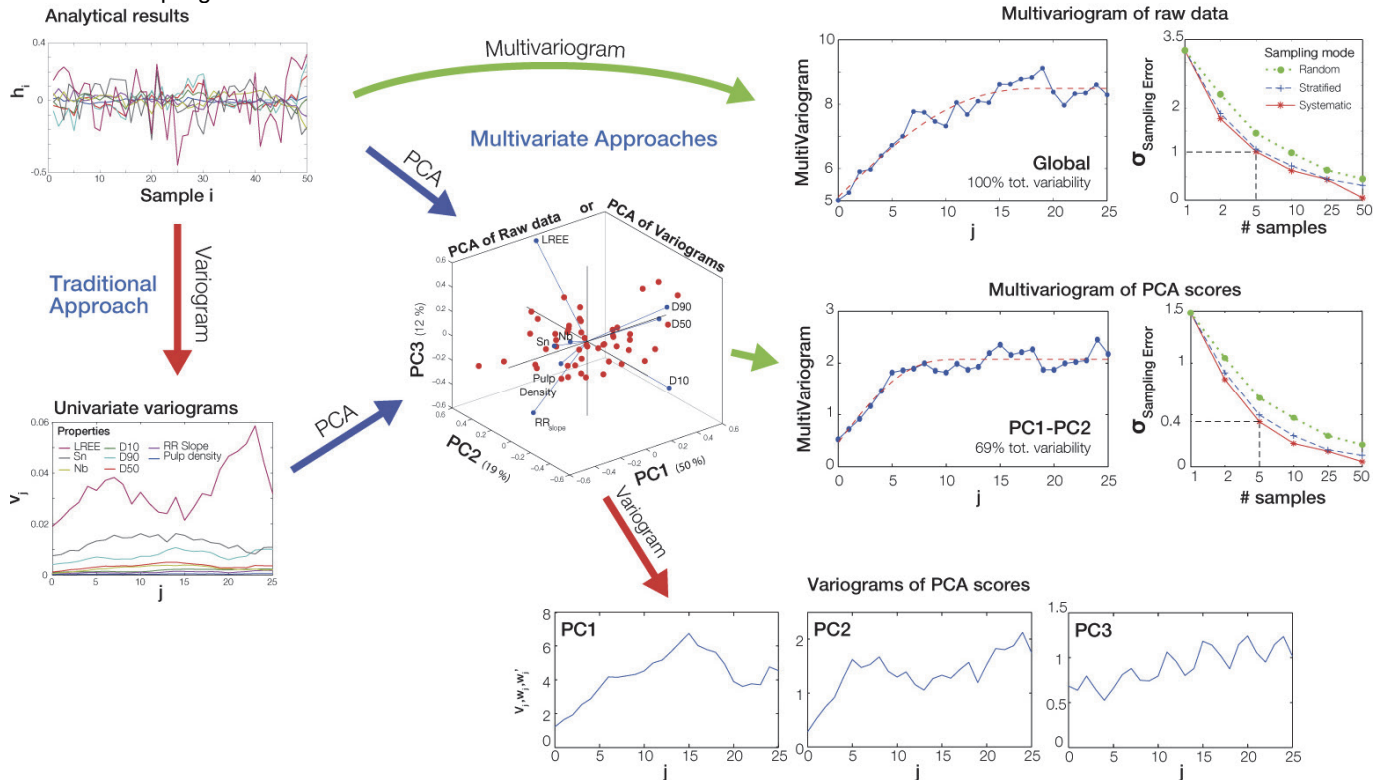

**Figure 1. Graphical abstract illustrating the univariate vs multivariate variographic approaches for process sampling explored in Dehaine et al. (2016)<sup>20</sup>.**

A similar approach was recently tested in water management for process water quality monitoring and environmental purposes<sup>41</sup>. Water quality is indicated by a large number of physico-chemical properties that must be monitored through time. The use of multivariate statistics allow to reducing the number of monitor charts needed, increase the signal to noise ratio while taking into consideration all properties and their correlation<sup>42</sup>. Therefore, the authors tested the use of multivariate approach to design sampling procedure for water quality control. The multivariate variographic analysis revealed the hidden cyclic variation through its ability to summarize the time variations and the correlation between multiple variables that were not visible through the classical univariate variogram approach. Similarly, to the previous case study<sup>20</sup>, the number of increments recommended by the global multivariogram is impractically high, but can be reduced by combining PCA to the multivariogram. This study highlights the benefits of using multivariate variography to improve water sampling procedures in the mining industry and to reduce both operational and environmental risks associated with water quality variability.

However, despite the reduction in global sampling variance through the use of PCA and even when choosing the properties of interest carefully, the resulting global variance obtained with the multivariogram may remain very high. In particular, some variables that contribute to a major proportion of the global (multivariate) variability could be less important for the process performance than others having a lower variability. Indeed, when sampling for geometallurgy testing, the sample can be considered as being representative when it results in acceptable levels of bias and precision for the outcome of test meaning the metallurgical performance index.

To address this issue, a new approach has been proposed at WCSB8, combining the multivariogram with process modelling and multivariate data analysis methods such as partial least squares (PLS) regression<sup>43</sup>. The approach was tested on industrial kaolin plant using sensor data as key process variables and a predictive process performance model based on PLS regression (Figure 2). The study showed that the PLS model regression coefficients can be used to weigh the variables according to their relevance for the process in a weighted metric to design an optimised sampling procedure in terms of frequency, sampling mode and number of increments according to the actual overall process performance. This approach has potentially many applications in geometallurgy as it would allow to tailor the metric used in the multivariogram according to the objective of the metallurgical test using existing physical or experimental models (Multiple Linear Regression, PLS, Design of Experiments). This would therefore allow to increase the representativeness of geometallurgy samples and decrease the risks associated with metallurgical performance variability.

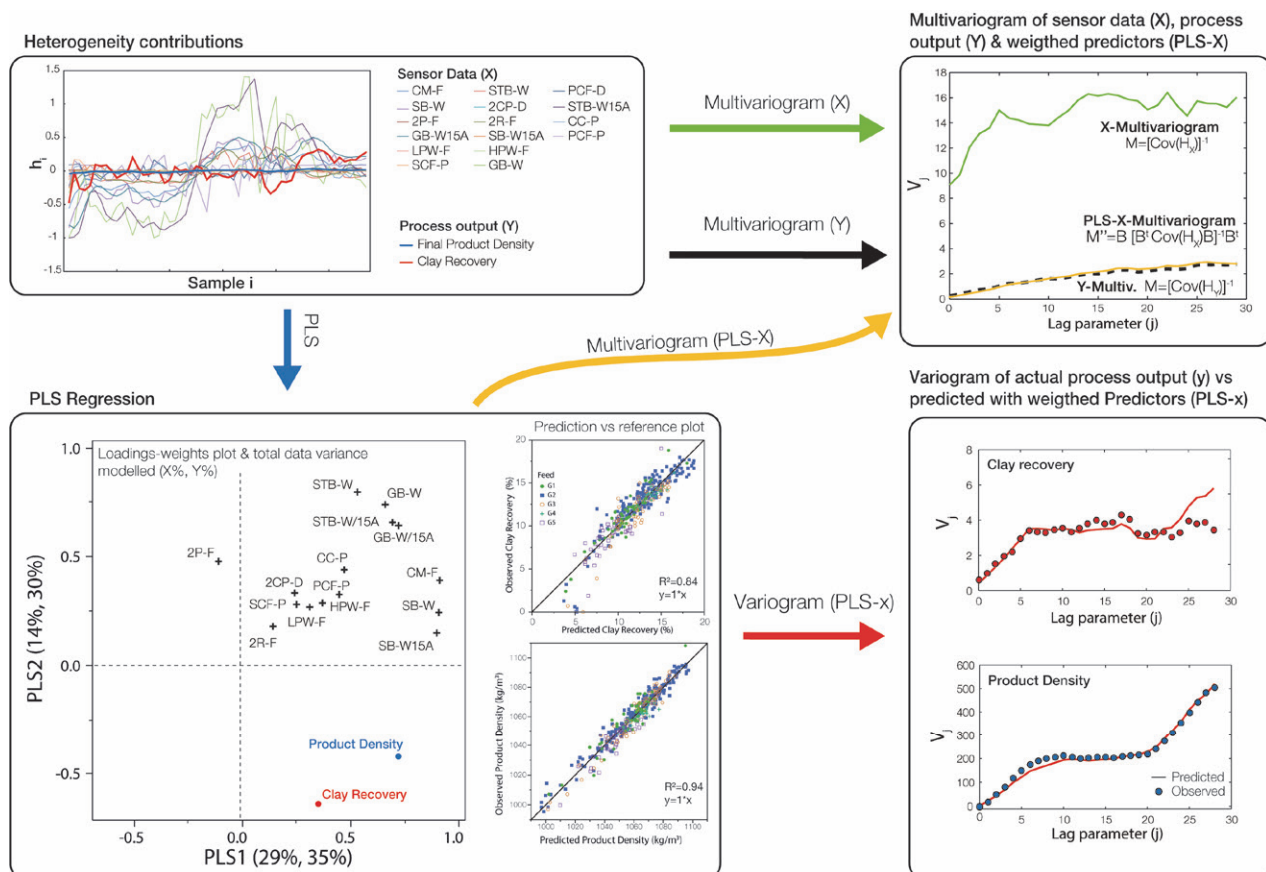

Figure 2. Graphical abstract illustrating the combined PLS-multivariate variographic approaches for process sampling explored in Dehaine *et al.* (2017)<sup>43</sup>.

## Discussion and conclusion

The examples described above show the strong benefits stemming from acknowledging that material heterogeneity as well as process heterogeneity is inherently multivariate in nature.

Acknowledging the multivariate nature of mineralisation and orebody heterogeneity, and the complex interactions involved in plant performance as well as the mining operation influence over the entire LOM, is at the essence of geometallurgy. It is therefore essential to reap the benefits from starting to integrate the multivariate scope during the design of geometallurgy sampling campaigns and not only for process sampling. But there is a long way to go, and much to be learned by all parties. It is certainly not just a matter of applying multivariate data analysis to any multi-variable, or multi-parameter assemblage encountered; there is an ongoing need for geological/mineralogical/geochemistry knowledge to support the multivariate scope. It is likely that the basic univariate scope will always be needed for fully comprehensive geometallurgy.

So, while only in its first stages within many geoscience fields, we predict an increasing role for the multivariate approach to almost all technological fields and application areas in which sampling plays a role. There is powerful insight to be gained by properly applied univariate variographic in technology and industry, *e.g.*, see the many examples in Engström, K.: “Sampling in Iron Ore Operations – Evaluation and Optimisation of Sampling Systems To Reduce Total Measurement Variability”<sup>44</sup> - and there is disruptive power in transgressing to a true multivariate scope<sup>41,43</sup>.

## Call to action

The multivariate approach has been described in adequate depth above – to present our main errand: This WCSB10 presentation is an *invitation* to all parties who would take an interest in venturing *outside* the conventional univariate box. An invitation to collaboration for pushing the envelope of sampling also into the multivariate realm ... You are invited – you are welcome!

## ORCID iDs

A. Q. Dehaine: <https://orcid.org/0000-0003-4674-3187>

B. K.H. Esbensen: <https://orcid.org/0000-1111-2222-3334>

Full publication list here: <https://kheconsult.com/>

## References

1. P. Gy, “Part V: Annotated literature compilation of Pierre Gy”, *Chemometrics and Intelligent Laboratory Systems*. **74**, 61-70 (2004). <https://doi.org/10.1016/j.chemolab.2004.05.010>
2. K.H. Esbensen, “TOS reflections: is there a third way? (to promote the Theory of Sampling)”, *TOS Forum*, 21-23. <https://doi.org/10.1255/tosf.122>
3. Q. Dehaine, “Loosen the TOS stipulations and face the economic consequences”, *Spectroscopy Europe*. **33**, 32-33 (2021).

- <https://doi.org/10.1255/sew.2021.a37>
4. S.C. Dominy, L. O'connor, A. Parbhakar-Fox, H.J. Glass, and S. Purevgerel. "Geometallurgy—A route to more resilient mine operations". *Minerals* **8**, 560 (2018). <https://doi.org/10.3390/min8120560>
  5. S.C. Dominy and L. O'Connor, "Geometallurgy – Beyond Conception", in *Proceedings of the 3rd AusIMM International Geometallurgy Conference*. AusIMM, pp. 3-10 (2016).
  6. R. Pell R, L. Tijsseling, K. Goodenough, F. Wall, Q. Dehaine, A. Grant, D. Deak, X. Yan and P. Whattoff, "Towards sustainable extraction of technology materials through integrated approaches". *Nature Reviews Earth & Environment*. **2**, 665–679 (2021) <https://doi.org/10.1038/s43017-021-00211-6>
  7. C. Lund and P. Lamberg, "Geometallurgy – A tool for better resource efficiency". *European Geologist*. **37**, 39-43 (2014). <https://doi.org/10.1039/C4SM02815E>
  8. S.R. Williams and J.M. Richardson, "Geometallurgy mapping: a new approach that reduces technical risks", in *Proceedings of 36th Annual Meeting of the Canadian Mineral Processors Conference*. CIM, pp. 241-268 (2004).
  9. S. P. Michaux and L. O'Connor, "How to Set Up and Develop a Geometallurgy Program", *GTK Open Work File Report 72/2019* (2020).
  10. S.C. Dominy, L. O'Connor and Y. Xie, "Sampling and Testwork Protocol Development for Geometallurgy Characterisation of a Sheeted Vein Gold Deposit", in *Proceedings of the 3rd AusIMM International Geometallurgy Conference*. AusIMM, pp. 97-112 (2016).
  11. K.H. Esbensen, "Theory of Sampling - what's next?", in: *Proceedings 8th World Conference on Sampling and Blending (WCSB8)*. AusIMM, pp. 29-38 (2017).
  12. R. Baumgartner, "Geometallurgy – Optimising the resource", in *Ore Dressing, Geometallurgy and Environmental Geochemistry of Mine Waste*. pp. 1-41 (2012).
  13. K. A. Bakeev, "Process Analytical Technology: Spectroscopic Tools and Implementation Strategies for the Chemical and Pharmaceutical Industries". 2nd ed, John Wiley & Sons (2010).
  14. N. McKay, J. Vann, W. Ware, W. Morley and P. Hodkiewicz, "Strategic and Tactical Geometallurgy - a systematic process to add and sustain resource value", in *Proceedings of the 3rd AusIMM International Geometallurgy Conference*. AusIMM, pp. 29-36 (2016).
  15. R.J. Holmes. "Correct sampling and measurement—the foundation of accurate metallurgical accounting", *Chemometrics and Intelligent Laboratory Systems*. **74**, 71-83 (2004). <https://doi.org/10.1016/j.chemolab.2004.03.019>
  16. S.C. Dominy, L. O'Connor, H.J. Glass, S. Purevgerel and Y. Xie, "Towards representative metallurgical sampling and gold recovery testwork programmes", *Minerals*. **8**, 193 (2018). <https://doi.org/10.3390/min8050193>
  17. V. Lishchuk, P. Lamberg and C. Lund, "Evaluation of sampling in geometallurgical programs through synthetic deposit model" in *Proceedings of the XXVIth International Mineral Processing Congress (IMPC)*. pp. 1-11 (2016).
  18. S.C. Dominy, L. O'Connor, Y. Xie and H.J. Glass, "Geometallurgy sampling protocol validation by bulk sampling in a sheeted vein gold deposit", in *Proceedings of the 8th World Conference on Sampling and Blending (WCSB8)*. AusIMM, pp. 195-196, (2017).
  19. F.F. Pitard, "Pierre Gy's Sampling Theory and Sampling Practice: Heterogeneity, Sampling Correctness, and Statistical Process Control". 2nd ed., CRC Press (1993).
  20. Q. Dehaine, L.O. Filippov and J.J. Royer, "Comparing univariate and multivariate approaches for process variograms: A case study", *Chemometrics and Intelligent Laboratory Systems*. **152**, 107-117 (2016). <https://doi.org/10.1016/j.chemolab.2016.01.016>
  21. Q. Dehaine, L.T. Tijsseling, H.J. Glass, T. Törmänen and A.R. Butcher, "Geometallurgy of cobalt ores: A review". *Minerals Engineering*. **160**, 106656 (2021). <https://doi.org/10.1016/j.mineng.2020.106656>
  22. C. Ramsey and K.H. Esbensen, "Inferential statistical sampling of hyper-heterogeneous lots with hidden structure: the importance of proper Decision Unit definition", *Spectroscopy Europe*. **34**, 25-32 (2022). <https://doi.org/10.1255/sew.2022.ax>
  23. K.H. Esbensen, "Introduction to the Theory and Practice of Sampling". IM Publications Open (2020). <https://doi.org/10.1255/978-1-906715-29-8>
  24. F. Pitard, "Theory of Sampling and Sampling Practice" 3rd ed. CRC Press, (2019).
  25. G. Lyman, "Theory and Practice of Particulate Sampling: An Engineering Approach". Materials Sampling & Consulting (2019).
  26. K.H. Esbensen KH. TOS Forum Issue 10, (2020).
  27. R.C.A. Minnitt and K.H. Esbensen, "Pierre Gy's development of the Theory of Sampling: a retrospective summary with a didactic tutorial on quantitative sampling of one-dimensional lots", *TOS Forum*. 7-19 (2017). <https://doi.org/10.1255/tosf.96>
  28. R.C.A. Minnitt and F.F. Pitard, "Application of variography to the control of species in material process streams: %Fe in an iron ore product", *Journal of the Southern African Institute of Mining and Metallurgy*. **108**, 109-122 (2008).
  29. K.H. Esbensen, "A multivariate perspective on Gy's Theory of Sampling – first foray", in *Proceedings 2nd World Conference on Sampling and Blending (WCSB2)*. AusIMM, p. 9 (2005).
  30. M.A. Oliver and R.A. Webster, "Geostatistical basis for spatial weighting in multivariate classification", *Mathematical Geology* **21**, 15-35 (1989). <https://doi.org/10.1007/BF00897238>
  31. P.O. Minkinen and K.H. Esbensen KH, "Multivariate variographic versus bilinear data modelling" *Journal of Chemometrics*. **28**, 395-410 (2014). <https://doi.org/10.1002/cem.2514>
  32. Z. Kardanpour, O.S. Jacobsen and K.H. Esbensen, "Local versus field scale soil heterogeneity characterization – a challenge for representative sampling in pollution studies", *SOIL Discussions*. **2**, 619-645 (2015). <https://doi.org/10.5194/soild-2-619-2015>

33. Z. Kardanpour, O.S. Jacobsen and K.H. Esbensen, "Soil heterogeneity characterization using PCA (Xvariogram) - Multivariate analysis of spatial signatures for optimal sampling purposes", *Chemometrics and Intelligent Laboratory Systems*. **136**, 24-35. (2014) <https://doi.org/10.1016/j.chemolab.2014.04.020>
34. Q. Dehaine and L.O. Filippov, "A multivariate approach for process variograms", in *Proceedings 2nd World Conference on Sampling and Blending (WCSB2)*, TOS Forum, 169-174 (2014). <https://doi.org/10.1255/tosf.76>
35. G. Bourgault and D. Marcotte, "Multivariable variogram and its application to the linear model of coregionalization", *Mathematical Geology*. **23**, 899-928 (1991). <https://doi.org/10.1007/BF02066732>
36. R. De Maesschalck, D. Jouan-Rimbaud and D.L. Massart. "The Mahalanobis distance". *Chemometrics and Intelligent Laboratory Systems*. **50**, 1-18 (2000). [https://doi.org/10.1016/S0169-7439\(99\)00047-7](https://doi.org/10.1016/S0169-7439(99)00047-7)
37. Q. Dehaine and L.O. Filippov, "Rare earth (La, Ce, Nd) and rare metals (Sn, Nb, W) as by-product of kaolin production, Cornwall: Part1: Selection and characterisation of the valuable stream", *Minerals Engineering*. **76**, 141-153 (2015). <https://doi.org/10.1016/j.mineng.2014.10.006>
38. Q. Dehaine, L.O. Filippov and R. Joussemet, "Rare earths (La, Ce, Nd) and rare metals (Sn, Nb, W) as by-products of kaolin production – Part 2: Gravity processing of micaceous residues", *Minerals Engineering*. **100**, 200-210 (2017). <https://doi.org/10.1016/j.mineng.2016.10.018>
39. L.O. Filippov, Q. Dehaine and I.V. Filippova, "Rare earths (La, Ce, Nd) and rare metals (Sn, Nb, W) as by-products of kaolin production – Part 3: Processing of fines using gravity and flotation", *Minerals Engineering*. **95**, 96-106 (2016). <https://doi.org/10.1016/j.mineng.2016.06.004>
40. Q. Dehaine, L.O. Filippov, H.J. Glass and G.K. Rollinson, "Rare-metal granites as a potential source of critical metals: A geometallurgy case study", *Ore Geology Reviews*. **104**, 384-402 (2019). <https://doi.org/10.1016/j.oregeorev.2018.11.012>
41. T.M.K. Le, Q. Dehaine, B. Musuku, N. Schreithofer and O. Dahl, "Sustainable water management in mineral processing by using multivariate variography to improve sampling procedures", *Minerals Engineering*. **172**, 107136 (2021). <https://doi.org/10.1016/j.mineng.2021.107136>
42. T.M.K. Le, M. Mäkelä, N. Schreithofer, O. Dahl, "A multivariate approach for evaluation and monitoring of water quality in mining and minerals processing industry", *Minerals Engineering*. **157** (2020). <https://doi.org/10.1016/j.mineng.2020.106582>
43. Q. Dehaine, L.O. Filippov and H.J. Glass, "Optimising multivariate variographic analysis with information from multivariate process data modelling (Partial Least Squares Regression)", in: *Proceedings of the 8th World Conference on Sampling and Blending (WCSB8)*. AusIMM, pp. 381-389 (2017).
44. K. Engström, "Sampling in iron ore operations: Evaluation and optimisation of sampling systems to reduce total measurement variability", PhD Thesis, Aalborg University. 2018. <https://doi.org/10.5278/vbn.phd.eng.00068>



## Framing TOS in risk assessment: an outreach perspective for the future

C. Paoletti<sup>a</sup> and K. H. Esbensen<sup>b</sup>

<sup>a</sup>European Food Safety Authority – EFSA. Via Carlo Magno 1/A, 43100 Parma, Italy. E-mail: [claudia.paoletti@efsa.europa.eu](mailto:claudia.paoletti@efsa.europa.eu)

<sup>b</sup>KHEConsulting, Copenhagen, Denmark. E-mail: [khe.consult@gmail.com](mailto:khe.consult@gmail.com)

Sampling is necessary every time inferences are to be made to take informed, optimal decisions in science, technology, industry, trade and commerce. For reasons extensively addressed over the last two decades, some fields, normally those where good sampling practices are a source of economic gain such as the mining/minerals/metals industrial sectors, explicate the role of sampling more than others. However, this is not the case within the realm of food and feed safety assessment, for example, where sampling continues - still today - to be perceived more as an economic burden and a technical necessity to be fulfilled because of regulatory demands, rather than a need to ensure reliable evidence to support management and regulatory decisions. This is true today and will become even more central in the future when society must address the challenges posed by the accelerating climate crisis, resources depletion and increasing food demand. Risk assessment and sampling are both probabilistic disciplines, the first devoted to estimate and minimise safety risks, the latter devoted to estimate and mitigate sampling risks (the effects of sampling errors). Here we offer an exposé with the aim of positioning TOS as an essential discipline and practical tool needed to ensure the best possible estimation of risks in support of safety decision-making and risk management in biological sciences, technology, industry, trade, commerce, and society at large. We demonstrate that sampling plays an integral, but an often much overlooked role in all these fields.

### Sampling: a border-crossing discipline

Sampling is a border-crossing discipline relevant every time inferences are to be made for taking informed, optimal decisions in science, technology, industry, trade and commerce. Scientific experiments and technical endeavours are very often dependent upon correct sampling at certain fundamental stages. Trade and international agreements recommend duplication (or even triplication) of primary samples to allow buyers and sellers performing analyses to compare results for contractual compliance purposes. Market and commercial agreements also rely on sampling for monitoring of quality.

Sampling plays a self-evident role in food and feed (F2) safety assessment as representativity of test materials for hazard identification, hazard characterization and exposure assessment are critical pre-requisites for taking informed decisions regarding public, animals, and environmental health<sup>1</sup>. Indeed, potential health risks for humans and animals can only be estimated accurately when exposure scenarios to a given food or feed are realistic, i.e. based on reliable sampling of food consumption habits. Furthermore, from an analytical perspective, the vast variety of food and feed matrices and commodities, raw or (semi-) processed, pose challenges to develop *appropriate* sampling strategies that best facilitate correct analytical methods<sup>1,2</sup>. Similar issues exist in other sectors of society, e.g., in pharmaceutical manufacturing.

Nonetheless, despite abundant evidence documenting the pervasive relevance of sampling, the Theory of Sampling (TOS) is not (yet) universally accepted.

Over the course of twenty years, working alone and together, exploring the application of TOS to very different disciplines, we felt challenged by two fundamentally contrasting attitudes towards TOS: **why sampling?** and **what benefits from proper sampling?** In this period, we have addressed, analysed and discussed on multiple occasions the likely causes for the divergent attitudes<sup>1,3</sup>, and have recently arrived at the understanding that at the root lies different *a priori* motivating factors driving the modes of application of TOS and practical sampling.

We here chose to focus on the mining/minerals/metals (M3) and food and feed (F2) sectors as lighthouse examples to *illustrate* this contrasting mindset. In the M3 sector, incorrect sampling unavoidably translates into hidden or clearly predictable economic losses. Consequently, TOS is here rightly perceived as the main underlying agent safeguarding business endeavours<sup>4</sup>.

In the equally broad global F2 sector however, sampling is seen as a tool to verify the accuracy of claims and/or the quality of products, forcing TOS more to be the operative agent with which to search for possible problems or to verify their absence, providing results in a statistical context offering merely degrees of confidence to inform the decision-making process. This is clearly a very different driver for invoking correct TOS when compared to safeguarding information factors for hardcore business interests.

## An emerging synoptic TOS framework

The contra-positioning of the underlying drivers for sampling is a key point dividing the views of samplers, process engineers, managers, regulators: even if from a technical and practical point of view exploration for, and processing of metalliferous resources is not so different from sampling for, say, aflatoxins in a 60,000-ton shipment of grain kernels — the motivations for investing intellect, time and money in correct, representative sampling are fundamentally different. In the M3 sector, the better the sampling the better for business, whereas in the F2 sector the better the sampling, the higher the risk of lot rejection or similar, which always carries a heavy negative economic and/or reputational penalty. The gamut of TOS applications in the last 20 years documents this dichotomy, witnessed by the comprehensive historical record of the Proceedings from ten World Conferences on Sampling and Blending (WCSB) in the period 2003-2022.

Notably, the practical application of TOS is virtually identical in all applied fields, including F2 and M3. When sampling heterogeneous materials of any nature, the task for practical sampling is to counteract the effects of the same sampling errors (SE), making use of the same Sampling Unit Operations (SUO) following the same Governing Principles (GP). The purpose of sampling is to conduct the optimal elimination and/or reduction of all nine recognised types of sampling error effects, to deliver a defensible representative analytical aliquot to the laboratory (horizontal yellow arrow in Figure 1 below). To be able to do this, all pre-analysis sampling operations must be representative, no exception allowed. In the schematic TOS framework developed by one of the present authors over the past 20 years<sup>5</sup>, the critical task of eliminating and reducing sampling error effects can also be seen as appropriate sampling error management.

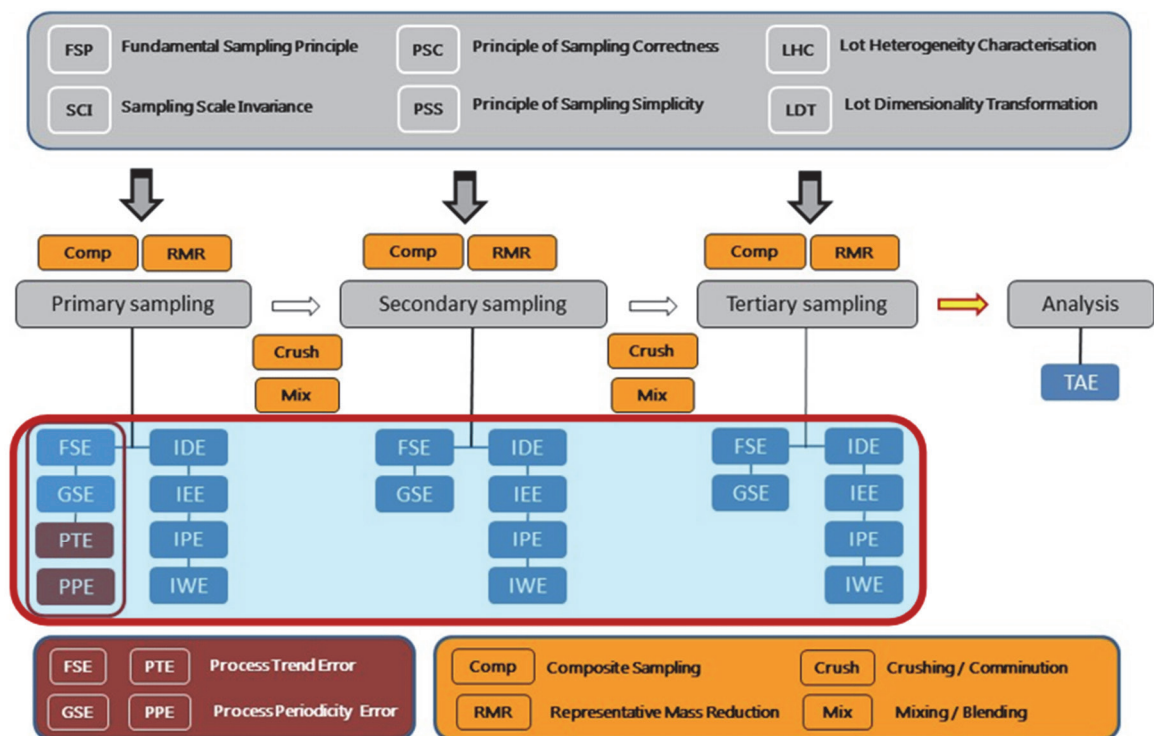

**Figure 1. Theory of Sampling (TOS), synoptic overview. Practical sampling is governed by six Governing Principles (GP) [top grey panel], using four Sampling Unit Operation (SUO) [bottom yellow panel] in an informed effort to reduce unwanted sampling error effects, IDE, IEE, IPE, IWE, GSE, FSE ... [blue rectangle]. This constitutes the realm of risk management in TOS: Correct, complete elimination of ISE and reduction of CSE sampling errors (incl. those occurring in the analytical laboratory).**

In the TOS realm, mitigation - i.e., management - of SE is a compound operation driven by the necessary sampling competency, which can range from adequate to non-existing, fighting material heterogeneity, which can also range from large to almost non-existing. The chief principle is clear: all sampling procedures must be representative. Therefore, the starting point is always the Lot Heterogeneity Characterisation (LHC) which allows the design, implementation and performance of optimal representative sampling with respect to the specific heterogeneity profile of a lot of interest. This framework representation has only very recently allowed the sampling community to recognise that proper handling of the gamut of sampling errors is in fact a critical risk management operation<sup>5</sup>, to be further elucidated below.

## Pushing the envelope for applied TOS

During their 20-year journey, the authors gradually grasped the dichotomous background attitudes explained above, but also experienced a certain level of frustration. Amidst tremendous success for the International Pierre Gy Sampling Association (IPGSA) concerning theoretical deepening, organisational development and TOS application in many traditional fields, we never felt quite satisfied with the degree to which our community has increased the diversity of application's fields beyond M3 for example in the medical arena. In the F2 sector significant progress has been made as today the concept of 'representativeness' is discussed, understood and incorporated in several of the key international standards governing the food and feed arena. This signifies an important step forward, triggered by exhaustive efforts in promulgating proper sampling in the F2 world. In this respect the challenging journey of broadening TOS's scope beyond the boundaries of the original realm of geological resources and raw materials has fared well, such that today, for example, also the pharmaceutical world considers TOS a valuable tool. Other progresses have been made recently in process industry at large, as witnessed by many contributions to WCSB10 as well as by DS3077 (2013)<sup>6</sup>. However, documenting representativeness with data-based evidence is not yet mandatory and often not even considered as a fundamental requirement for good decision making-process in many of the applied fields where sampling *de facto* takes place.

Here we wish to continue promoting the expansion of TOS beyond the boundaries of M3, where things started and remained confined for long, by elaborating on the probabilistic nature that sampling and risk assessment have in common: proper sampling estimates and minimises the effects of unmitigated sampling errors, risk assessment estimates and minimises the risk associated to a given hazard in each activity or undertaking.

## From M3 to F2 – and beyond

The market we live in was for a long time steadily increasing in its global dimension and interconnectedness, and until recently most models indicated that this trend would continue. It is yet to early to assess the magnitude of the effects on the global marketplace by the war in Ukraine, but severe global disruptive impacts are certain.

Despite the universally recognised right of any citizen to be guaranteed the same level of protection, as of today risk assessment (RA) approaches in food and feed safety are not harmonised, creating trade problems and inequality in safety protection around the world. The future will demand even stronger efforts towards RA harmonization by exploring innovative approaches to resolve the problems that prevent this aspiration today. The development of large databases to share information is strongly needed; the revision RA methodologies to address new food products continuously emerging and imposing new interdisciplinary approaches, is also necessary. To effectively tackle F2 safety problems, we must develop new approaches capable of considering the multiple interactions that the complexity of innovative food producing systems will require in the future. But most importantly, our generation has the responsibility of ensuring the sustainability of food/feed industry, a big challenge that governmental organizations are trying hard to resolve.

In this setting, correct sampling is and will continue to play an important role in ensuring that all the relevant information necessary to take the best possible decisions is collected appropriately. Sampling is about being accountable for the trust that society puts into governmental and inter-governmental regulatory and control systems for the safety of food and feed products of today and of the future. Society has no other choice: we all eat food that we buy at supermarkets, trusting it is safe, trusting that the control system works to protect us, the consumers, the citizens.

This logic can to a large degree be transferred to many other fields of TOS application like pharmaceutical industry, chemical industry, medical sector, packaging industry just to name a few. The technical discipline TOS serves a societal role of the greatest importance, in effect putting a substantial ethical responsibility on these communities, albeit this role is almost totally unseen and unrecognised by the world's populations at large.

## Going beyond the *status quo*

For the past 20 years the authors have documented how sampling enters full force in food and feed safety assessment, even though most times this means raising costs rather than resulting in economic gain. This opened our eyes towards the hidden common aspects between the somewhat crass utilitarian business role of TOS in the M3 sectors and its role in the service of public and animal health.

But these apparently diverse roles for applied TOS can also be seen from a common viewpoint, with a much broader impact, introducing the unifying concepts of risk, risk assessment and risk management in the sampling arena. In the following it is assumed that the reader is familiar with TOS' basic systemic elements of Governing Principles (GP), Sampling Unit Operations (SUO) and Sampling Error Managements rules (SEM).

## Framing TOS in risk assessment: an outreach perspective for the future

### Fundamental definitions

- **Risk** = probability that something unknown and/or unwanted happens.
- **Risk assessment** = the process to identify risks, so they can be minimised to maximise a critical subject-matter goal e.g., consumers protection (societal scope), economic gains (business scope), or sampling variability (technical quality control/quality assurance/quality management scope).



- **Risk management** = the process of managing and monitoring risks, optimising success by minimising them as much as possible. Risk management capitalises on data as an asset and data must be relevant and reliable i.e., representative.

#### Fundamental definitions applied to TOS

- **TOS Risk** = probability of unwanted, unmitigated sampling errors (SE) - both incorrect (ISE) and correct (CSE) sampling errors - resulting in uncontrolled, excessive sampling variability. This is a scenario damaging every stakeholder.
- **TOS Risk Assessment** = the process to estimate the effects of unmitigated sampling errors in terms of ISE + CSE and material heterogeneity - i.e., the total sampling error (TSE) - employing, for example, pairwise sampling, replicated experiments or variographic characterisation, see TOS literature for details.
- **TOS Risk management** = the process to mitigate sampling error effects, preferentially through the complete elimination of ISE and the concomitant reduction of CSE.

Positioning TOS as a risk management endeavour provides a broader perspective, both at the theoretical as well as the practical level, illustrating the far-reaching scope and responsibility vested in the TOS community. This awareness already began with the recent monumental publication “Economic arguments for representative sampling” addressing how to engage better with management, offering more than 25 different point of views<sup>4</sup>. This collective publication expresses well the *status quo* for IPGSA and identifies areas where IPGSA community needs to expand its activities to promulgate TOS as a tool necessary for optimal risk management decisions across many disciplines.

Sampling is about providing reliable data and information necessary to take managerial decisions. In some areas such information is sufficient on its own, in others additional considerations must be taken into account. In the M3 sector, once the effects of unmitigated sampling errors are estimated (TOS risk assessment), the decision is univocal: eliminate ISE and reduce CSE to the minimum possible to maximise business achievement (TOS risk management). The IPGSA community is very familiar with this logic. In other sectors, however, risk assessment outcome is not the only factor considered in the managerial decision-making process. This is the case, for example, for F2 where ethical, political and societal considerations must also be taken into account to reach a compound final decision.

#### Food for thought

Because of its complexity, risk management is a particularly challenging endeavour. The goal of correct risk management is not elimination of all risks (which would be an impossibility), but rather getting to know which risks are worth taking, which must be minimised, and which ones have enough of an assured negative pay-out to not take them.

The IPGSA community should expand its horizon and offer its expertise to all sectors in society where TOS is a *de facto* essential tool to deliver the appropriate information for critical decision making. Correct sampling is about being accountable for the trust that society puts into decision making systems. Society has no other choice: we all consume what is available on the market trusting its quality and safety, trusting that the control system has worked as intended. “*Consumption*” shall be seen here in a much broader context than just human and animal consumption of food and feed, as the responsible *use* of resources and commodities. Upon reflection, there are virtually no examples of management decision making in the technical and industrial society not based on proper sampling somewhere in the information flow involved, although this may in many cases be a much-overlooked insight.

Explicating the risk management scope of sampling allows a fresh and powerful look at some of the current hindrances revealed for a more successful drive to go beyond traditional borders. Framed in this perspective, TOS becomes an essential practical tool needed to ensure the best possible estimation of risks to inform safety decision-making across societal sectors at large, including biological sciences, agro-business, technology, industry, trade, commerce, environment. Successful risk management considers the full range of risks, examines the relationship among the identified risks and their cascading impact(s). In some areas the number of factors informing management decision is limited, like in the M3 sector where the attention is always tightly focused on mitigation of sampling error effects on the business bottom line. In others, like F2, the primary consideration is always human and animals’ health protection, however other factors such as economic costs, benefits, technical feasibility, risk perceptions are also considered appropriate.

Nonetheless, TOS is indispensable under either scenario – and far beyond. It is hoped that the risk assessment scope will allow the IPGSA community an easier, and perhaps more powerful, way to reach out to business, commerce, trade as well as regulating and law-enforcement authorities by starting to speak a more common language.

#### Disclaimer

Claudia Paoletti is employed by the European Food Safety Authority (EFSA). The positions and opinions presented in this article are those of the author alone and do not necessarily represent the views or scientific works of EFSA.

## References

1. H.A. Kuiper and C. Paoletti, “Food and feed safety assessment: the importance of proper sampling”, *J. AOAC Int.* 98(2), 252–258 (2015). <https://doi.org/10.5740/jaoacint.15-007>
2. K.H. Esbensen, C. Paoletti and N. Theix (Eds), “Special Guest Editor Section (SGE): Sampling for Food and Feed Materials”, *J. AOAC Int.* 249–320 (2015). <http://ingentaconnect.com/content/aoac/jaoac/2015/00000098/00000002>
3. C. Paoletti. Food and feed sampling: balancing ethics and money. In “Economic Arguments for Representative Sampling”. Spectroscopy Europe sampling column SE33-7 (2022). DOI: <https://doi.org/10.1255/sew.2021.a30>
4. K. H. Esbensen. Ed. “Economic Arguments for Representative Sampling”. Spectroscopy Europe Sampling column SE33-7 (2022). DOI: <https://doi.org/10.1255/sew.2021.a30>
5. K.H. Esbensen, Introduction to the Theory and Practice of Sampling. IM Publications Open (2020). <https://doi.org/10.1255/978-1-906715-29-8>
6. DS3077, Representative Sampling— Horizontal Standard. Danish Standards (2013). <http://www.ds.dk>



## Gy's Discrete Heterogeneity and the Grouping and Segregation Variance

Geoffrey J Lyman

Materials Sampling & Consulting. E-mail: geoff.lyman@gmail.com

This paper returns to Gy's work to make a recapitulation of his derivation of the constitutional and distributional heterogeneity of a particulate material with a careful delineation of the assumptions that he employed to arrive at expressions for the fundamental sampling variance and the variance due to distributional heterogeneity or the grouping and segregation variance. Gy derives a link between the constitutional and distributional heterogeneity based on the assumption that increments are 'similar'. This in fact requires that potential increments contain the same number of particles which is very restrictive. Gy's expressions are explored with numerical examples which demonstrate that these may be valid only under limited circumstances. The second part of the paper provides a derivation that presents an alternative approach to the variance of sampling of a highly segregated particulate material. It is shown that when all particles have the same mass as can be expected under Gy's assumptions, the new expression coincides with Gy's. The new derivation is essentially free of assumptions regarding particle numbers and masses in increments and appeals to common sense regarding the extraction of samples by mechanically correct samplers. The new approach provides an expression for the variance due to grouping and segregation which involves the properties of the particulate material and the same variable used by Gy to express the extent of segregation of the lot. The grouping factor  $\gamma$  used by Gy is eliminated from consideration.

*Editor's ingress: Regrettably, this paper could not be presented either orally or on-line at WCSB10. It has, therefore, not been subjected to the open scientific discussion which is customary in academe, but only to a closed proxy through reviews and rebuttals via the Editor's desk. This paper deserves more, however, not least because of the author's career-long contributions to the science and technology of sampling. The Editor has, therefore, decided to call for a public discussion as part of the next regular issue of TOS Forum. Readers of this ingress may consider themselves invited; more information and directions will be forthcoming on the homepage of the International Pierre Gy Sampling Association (<https://intsamp.org>), or e-mail the Editor with your comments ([khe.consult@gmail.com](mailto:khe.consult@gmail.com)).*

### Introduction

The understanding of sampling uncertainty due to particle grouping and segregation is a long-standing issue in particulate sampling theory. The derivation by Gy is complex indeed and not made easier due to the volume of notation that must be used to arrive at a result. The issue starts with Gy's analysis of distributional heterogeneity and then follows on to his discussion of the selection variances; no easy study to digest. Few seem to have done so.

To understand Gy's definitions of distributional heterogeneity, it is necessary to go back to his development in Chapter 19 of his book of 1982 or equivalent expositions. It can be shown that there are assumptions made which limit the magnitude of the distributional heterogeneity and so subsequent variances such as the grouping and segregation variance. These assumptions are also necessary to arrive at Gy's link between constitutional and distributional heterogeneity. After a comprehensive review of Gy's derivation of the fundamental and grouping and segregation variances, an alternative approach to deriving a variance due to particle segregation is presented herein based on the concept of correct extraction of constant volume increments. The new result is the same as Gy's result when assumptions regarding increment masses and particle numbers as suggested by Gy are invoked. This new approach provides considerable insight into the challenge of describing sampling variance due to segregation.

### Gy's Notation and Assumptions

While this is repetitive of Gy's section 19.1 [1], it is necessary to define and appreciate the basis of Gy's arguments and derivations. Italics have been used to identify terms that have a specific meaning. Summation indices have been changed in line with usual mathematical usage and additional subscripts added to ensure that a variable is uniquely defined. There is little alternative to such a complex notation.

The *lot* is defined as a set of *units*  $U_i; i = 1, \dots, N_U$  such as

- the set  $L_F$  of *fragments*  $F_j; j = 1, \dots, N_F$  where  $N_F$  is the number of *fragments* in the *lot*
- the set  $L_G$  of *groups*  $G_j; j = 1, \dots, N_G$  of *fragments* in the *lot* which are complementary (no overlap or intersection)

The *groups* may be thought of as the *potential increments* that can be taken from the *lot*.

It is **assumed** that all groups have about the same *magnitude*, the definition of the *magnitude* is not made clear until later.

$L$	A lot of particulate material having a mass $M_L$ , containing a mass of <i>critical analyte</i> (CA) $A_L$ with $a_L$ the <i>critical content</i> (concentration, CC)
$F_i$	A <i>fragment</i> belonging to $L$ having a mass $M_{F_i}$ , a mass of CA $A_{F_i}$ with a CC $a_{F_i}$ ; $i = 1, \dots, N_F$
$U_i$	A non-specified <i>unit</i> belonging to $L$ containing a mass $M_{U_i}$ , a mass of CA $A_{U_i}$ with CC $a_{U_i}$ ; $i = 1, \dots, N_U$
$G_j$	A <i>group of fragments</i> belonging to $L$ each containing a mass $M_{G_j}$ , a mass of CA $A_{G_j}$ with a CC $a_{G_j}$ ; $j = 1, \dots, N_G$
$F_{G_j}$	A <i>fragment</i> belonging to $G_j$ with mass $M_{F_{G_j}}$ with a mass of CA $A_{F_{G_j}}$ and with a CC $a_{F_{G_j}}$ ; $i = 1, \dots, N_{G_j}$

Material balances dictate that the following relationships hold

$$M_L = \sum_{i=1}^{N_G} M_{G_i} = \sum_{j=1}^{N_G} \sum_{i=1}^{N_{G_j}} M_{F_{G_j,i}} = \sum_{i=1}^{N_F} M_{F_i} \quad (1)$$

$$A_L = \sum_{j=1}^{N_G} A_{G_j} = \sum_{j=1}^{N_G} \sum_{i=1}^{N_{G_j}} A_{F_{G_j,i}} = \sum_{i=1}^{N_F} A_{F_i} \quad (2)$$

$$a_L = \frac{A_L}{M_L} = \frac{\sum_{j=1}^{N_G} A_{G_j}}{\sum_{i=1}^{N_G} M_{G_i}} = \frac{\sum_{j=1}^{N_G} \sum_{i=1}^{N_{G_j}} A_{F_{G_j,i}}}{\sum_{j=1}^{N_G} \sum_{i=1}^{N_{G_j}} M_{F_{G_j,i}}} = \frac{\sum_{i=1}^{N_F} A_{F_i}}{\sum_{i=1}^{N_F} M_{F_i}} \quad (3)$$

The assumption that the groups are of 'similar magnitude' is a strong one. Gy<sup>1</sup> makes reference to the material of Chapter 16 which is concerned with increment delimitation and is clearly oriented to sampling as in 'stopped belt' sampling or sampling from a one-dimensional moving stream. In such a case, unless the mass per unit length of the lot varies substantially, the increments are of similar *volume*. When a tool is used to collect an increment in a correct manner, the increments will tend to be of similar volume as well. Sampling with an auger or taking a drill core creates increments of similar volume.

If magnitude relates to similar number of particles in each group, then all groups must have similar size distributions. Similar masses for the groups suggests a similar mean density. Similar composition is not a restriction to make as this defeats the analysis where differences in composition are being sought.

Gy further defines average properties of the groups.

$\bar{F}$	The average fragment belonging to $L$ having a mass $M_{\bar{F}}$ , a mass of CA $A_{\bar{F}}$ with a CC $a_{\bar{F}}$ . Note that the average is a number average. The average mass of a fragment must be $M_{\bar{F}} = \frac{M_L}{N_F}$ The average CA must be $A_{\bar{F}} = \frac{A_L}{N_F}$ The average CC must be $a_{\bar{F}} = \frac{A_{\bar{F}}}{M_{\bar{F}}} = \frac{A_L}{M_L}$
$\bar{G}$	The average group belonging to $L$ each containing a mass $M_{\bar{G}}$ , a mass of CA $A_{\bar{G}}$ with a CC $a_{\bar{G}}$ The average mass of a group is $M_{\bar{G}} = \frac{M_L}{N_G}$ The average CA must be $A_{\bar{G}} = \frac{A_L}{N_G}$ The average CC must be $a_{\bar{G}} = \frac{A_{\bar{G}}}{M_{\bar{G}}} = \frac{A_L}{M_L} = a_L$
$\bar{F}_{G_j}$	The average fragment belonging to $G_j$ with mass $M_{\bar{F}_{G_j}}$ with a mass of CA $A_{\bar{F}_{G_j}}$ with a CC $a_{\bar{F}_{G_j}}$ ; $j = 1, \dots, N_G$ The average mass of a fragment in the $j$ group is $M_{\bar{F}_{G_j}} = \frac{M_{G_j}}{N_{G_j}}$ The average CA of a fragment in the $j^{\text{th}}$ group is $A_{\bar{F}_{G_j}} = \frac{A_{G_j}}{N_{G_j}}$ The average CC of a fragment in the $j^{\text{th}}$ group is $a_{\bar{F}_{G_j}} = \frac{A_{\bar{F}_{G_j}}}{M_{\bar{F}_{G_j}}} = \frac{A_{G_j}}{M_{G_j}} = a_{G_j}$

So we have a situation where the groups can vary in composition, but their average composition must be that of the lot. We must think of the groups as having a statistical distribution of composition about the average composition of the lot.

Next, the definition of heterogeneity needs to be considered. Gy defines the heterogeneity carried by a particle as the difference between the analyte content of the particle and the lot weighted by the particle mass and then divided by the analyte mass in the average particle of the lot, so

$$h_i = \frac{(a_{F_i} - a_L)M_{F_i}}{A_F} = \frac{(a_{F_i} - a_L)M_{F_i}}{a_F M_F} = \frac{(a_{F_i} - a_L)M_{F_i}}{a_L \frac{M_L}{N_F}} = \frac{N_F (a_{F_i} - a_L)M_{F_i}}{a_L M_L} \quad (4)$$

He defines the heterogeneity carried by the  $i^{\text{th}}$  fragment in the  $j^{\text{th}}$  group in an analogous manner

$$h_{FG_j,i} = \frac{(a_{FG_j,i} - a_L)M_{FG_j,i}}{a_F M_F} = \frac{N_F (a_{FG_j,i} - a_L)M_{FG_j,i}}{a_L M_L} \quad (5)$$

The next question is the heterogeneity carried by the average fragment within the  $j^{\text{th}}$  group. This is defined as

$$h_{FG_j} = \frac{(a_{FG_j} - a_L)M_{FG_j}}{a_F M_F} = \frac{N_F (a_{FG_j} - a_L)M_{FG_j}}{a_L M_L} = \frac{N_F (a_{G_j} - a_L)M_{G_j}}{a_L M_L N_{G_j}} \quad (6)$$

Gy now considers the average of the heterogeneity carried by the  $i^{\text{th}}$  fragment in the  $j^{\text{th}}$  group and this is

$$\frac{1}{N_{G_j}} \sum_{i=1}^{N_{G_j}} h_{FG_j,i} = \frac{N_F}{a_L M_L} \frac{1}{N_{G_j}} \sum_{i=1}^{N_{G_j}} (a_{FG_j,i} - a_L)M_{FG_j,i} = \frac{N_F}{a_L M_L} \frac{1}{N_{G_j}} \left[ \sum_{i=1}^{N_{G_j}} a_{FG_j,i} M_{FG_j,i} - a_L \sum_{i=1}^{N_{G_j}} M_{FG_j,i} \right] \quad (7)$$

But the first sum on the right is the mass of analyte in the  $j^{\text{th}}$  group which is  $a_{G_j} M_{G_j}$  and the second sum is the mass of the  $j^{\text{th}}$  group  $M_{G_j}$  so

$$\frac{1}{N_{G_j}} \sum_{i=1}^{N_{G_j}} h_{FG_j,i} = \frac{1}{N_{G_j}} \frac{N_F}{a_L M_L} (a_{G_j} - a_L)M_{G_j} = h_{FG_j} \quad (8)$$

which means that heterogeneity carried by the average particle of the  $j^{\text{th}}$  group is the numerical average of the heterogeneities carried by the fragments in the  $j^{\text{th}}$  group. So the heterogeneities can be averaged numerically as they relate to masses of analyte and masses of particles unlike particle compositions.

The heterogeneity carried by a group of particles is defined as

$$h_{G_j} = \frac{(a_{G_j} - a_L)M_{G_j}}{a_G M_G} = \frac{N_G (a_{G_j} - a_L)M_{G_j}}{a_L M_L} \quad (9)$$

Gy then makes a comparison between the heterogeneity carried by the  $j^{\text{th}}$  group,  $h_{G_j}$  and that carried by the average particle of the group,  $h_{FG_j}$ . From (6) and (9) we have

$$h_{FG_j} = \frac{N_F (a_{G_j} - a_L)M_{G_j}}{a_L M_L N_{G_j}} \quad (10)$$

and

$$h_{G_j} = \frac{N_G (a_{G_j} - a_L)M_{G_j}}{a_L M_L} \quad (11)$$

so if

$$(12)$$

$$\frac{N_F}{N_{G_j}} = N_G$$

these heterogeneities are equal. This requires that all groups have the same number of particles

$$N_{G_j} = \frac{N_F}{N_G} \quad (13)$$

The constitutional heterogeneity of the lot,  $CH_L$  is now defined as the variance of the heterogeneity carried by the fragments of the lot. Since the expected value of the heterogeneity is zero,

$$\begin{aligned} CH_L &= \sigma^2(h_i) = \frac{1}{N_F} \sum_{i=1}^{N_F} h_i^2 \\ &= \frac{1}{N_F} \sum_{i=1}^{N_F} \left[ \frac{N_F (a_{F_i} - a_L)M_{F_i}}{a_L M_L} \right]^2 \\ &= \frac{N_F}{a_L^2 M_L^2} \sum_{i=1}^{N_F} (a_{F_i} - a_L)^2 M_{F_i}^2 \end{aligned} \quad (14)$$

$$\begin{aligned}
CH_L &= \sigma^2(h_i) = \frac{1}{N_F} \sum_{i=1}^{N_F} h_i^2 \\
&= \frac{1}{N_F} \sum_{i=1}^{N_F} \left[ \frac{N_F (a_{F_i} - a_L) M_{F_i}}{a_L M_L} \right]^2 \\
&= \frac{N_F}{a_L^2 M_L^2} \sum_{i=1}^{N_F} (a_{F_i} - a_L)^2 M_{F_i}^2
\end{aligned}$$

This is a particle mass squared weighted second moment of the particle compositions about the mean composition of the lot. Noting that  $(a_{F_i} - a_L) M_{F_i}$  is the excess/deficit mass of analyte from the mean composition, the summation is total of this excess/deficit squared and the sum vanishes only if all particles have the same analyte content. It is easy to visualise a probability density function for  $(a_{F_i} - a_L) M_{F_i}$  which straddles the origin. The sum above divided by the number of fragments is the variance of this density function which is discrete for a finite number of particles. Note that  $CH_L$  is a very large number in general as it is proportional to the number of particles in the lot; it is an extensive (depends on lot mass) rather than intensive (independent of lot mass) property of the lot.

We note here that Pitard<sup>2</sup> defines a practical measure of the heterogeneity of the lot by multiplying  $CH_L$  by the average mass of a fragment. The quantity was also recognised by Gy as the 'invariant of heterogeneity', hence the notation 'IH'. Pitard writes

$$IH_L = \frac{M_L}{N_F} CH_L = \frac{1}{M_L} \sum_{i=1}^{N_F} \left( \frac{a_{F_i} - a_L}{a_L} \right)^2 M_{F_i}^2 \quad (15)$$

which has units of mass but is an intrinsic property of the lot. The  $i^{\text{th}}$  fragment mass can be characterised by a volume  $v_i$  and density  $\rho_i$ ,  $M_{F_i} = v_i \rho_i$  and  $M_{F_i}/M_L$  is the mass fraction  $x_i$  of the particle in the lot, so

$$IH_L = \sum_{i=1}^{N_F} x_i v_i \rho_i \left( \frac{a_{F_i} - a_L}{a_L} \right)^2 \quad (16)$$

The distributional heterogeneity  $DH_L$  is defined as the variance of the heterogeneities  $h_{G_j}$  carried by the groups  $G_j$  in the lot.

$$\begin{aligned}
DH_L &= \sigma^2(h_{G_j}) = \frac{1}{N_G} \sum_{j=1}^{N_G} h_{G_j}^2 = \frac{1}{N_G} \sum_{j=1}^{N_G} \left[ \frac{N_G}{a_L M_L} (a_{G_j} - a_L) M_{G_j} \right]^2 \\
&= \frac{N_G}{a_L^2 M_L^2} \sum_{j=1}^{N_G} (a_{G_j} - a_L)^2 M_{G_j}^2
\end{aligned} \quad (17)$$

Gy makes a comparison of  $DH_L$  and  $CH_L$  under the assumption that all groups are 'similar' and contain essentially the same number of fragments. However, if the groups are not so constrained, then we could choose the groups in any reasonable way. One such choice of groups is to put every particle into its own group. Then

$$DH_L = \sigma^2(h_{G_j}) = \frac{N_F}{a_L^2 M_L^2} \sum_{j=1}^{N_F} (a_{F_j} - a_L)^2 M_{F_j}^2 \quad (18)$$

and this is just  $CH_L$ . But the only similarity between the groups is that they contain one particle and with a size distribution, it is not really true that the groups are similar, certainly not in regard to their mass. Note also that the sampling has been carried out by number. The value of  $DH_L$  like  $CH_L$  is a large number due to the proportionality to the number of fragments in the lot.

To conclude the analysis of  $DH$  according to Gy, we follow his analysis of section 19.3.4. It is possible to write that

$$h_i = \frac{N_F (a_{F_i} - a_L) M_{F_i}}{a_L M_L} \equiv h_{FG,i} = \frac{N_F (a_{FG,i} - a_L) M_{FG,i}}{a_L M_L} \quad (19)$$

as each term corresponds to a analyte content of a fragment and a mass of a fragment and both are defined over the full set of fragments in the lot.

One may then introduce an expression or identity

$$h_i \equiv h_{FG,i} = (h_{FG,i} - h_{G_j}) + h_{G_j} \quad (20)$$

If we then square both sides and sum, we have

$$\begin{aligned}
\sum_{i=1}^{N_F} h_i^2 &= \sum_{j=1}^{N_G} \sum_{i=1}^{N_{G_j}} \left[ (h_{FG,i} - h_{G_j}) + h_{G_j} \right]^2 \\
&= \sum_{j=1}^{N_G} \sum_{i=1}^{N_{G_j}} \left\{ (h_{FG,i} - h_{G_j})^2 + 2h_{G_j} (h_{FG,i} - h_{G_j}) + h_{G_j}^2 \right\}
\end{aligned} \quad (21)$$

Let us examine the middle term. We write

$$2 \sum_{j=1}^{N_G} \sum_{i=1}^{N_{G_j}} h_{G_j} \left( \frac{N_F (a_{FG_j,i} - a_L) M_{FG_j,i}}{a_L M_L} - \frac{N_G}{a_L M_L} (a_{G_j} - a_L) M_{G_j} \right) = \quad (22)$$

$$2 \sum_{j=1}^{N_G} h_{G_j} \left( \sum_{i=1}^{N_{G_j}} \frac{N_F (a_{FG_j,i} - a_L) M_{FG_j,i}}{a_L M_L} - \sum_{i=1}^{N_{G_j}} \frac{N_G}{a_L M_L} (a_{G_j} - a_L) M_{G_j} \right)$$

Then the term in brackets is

$$\sum_{i=1}^{N_{G_j}} \frac{N_F (a_{FG_j,i} - a_L) M_{FG_j,i}}{a_L M_L} - \sum_{i=1}^{N_{G_j}} \frac{N_G}{a_L M_L} (a_{G_j} - a_L) M_{G_j} \quad (23)$$

$$= \frac{N_G}{a_L M_L} \left[ \frac{N_F}{N_G} \sum_{i=1}^{N_{G_j}} (A_{FG_j,i} - a_L M_{FG_j,i}) - \sum_{i=1}^{N_{G_j}} (A_{G_j} - a_L M_{G_j}) \right]$$

$$= \frac{N_G}{a_L M_L} \left[ (A_{G_j} - a_L M_{G_j}) \left( \frac{N_F}{N_G} - N_{G_j} \right) \right]$$

and if the number of particles in all groups is  $N_{G_j} = \frac{N_F}{N_G}$  for all  $j$ , the term vanishes but not otherwise. If it does not vanish

we have

$$\sum_{i=1}^{N_F} h_i^2 = \sum_{j=1}^{N_G} \sum_{i=1}^{N_{G_j}} \left\{ (h_{FG_j,i} - h_{G_j})^2 + 2h_{G_j} (h_{FG_j,i} - h_{G_j}) + h_{G_j}^2 \right\} \quad (24)$$

$$= \sum_{j=1}^{N_G} \sum_{i=1}^{N_{G_j}} (h_{FG_j,i} - h_{G_j})^2 + 2 \frac{N_G}{a_L M_L} \sum_{j=1}^{N_G} h_{G_j} \left[ (A_{G_j} - a_L M_{G_j}) \left( \frac{N_F}{N_G} - N_{G_j} \right) \right] + \sum_{j=1}^{N_G} \sum_{i=1}^{N_{G_j}} h_{G_j}^2$$

$$= \sum_{j=1}^{N_G} \sum_{i=1}^{N_{G_j}} (h_{FG_j,i} - h_{G_j})^2 + 2 \left( \frac{N_G}{a_L M_L} \right)^2 \sum_{j=1}^{N_G} (A_{G_j} - a_L M_{G_j})^2 \left( \frac{N_F}{N_G} - N_{G_j} \right) + \sum_{j=1}^{N_G} \sum_{i=1}^{N_{G_j}} h_{G_j}^2$$

The middle term can have negative and positive terms depending on the number of particles in the  $j^{\text{th}}$  group being higher or lower than a mean value of  $N_F/N_G$ . If the groups all contain the same number of particles, we have

$$\sum_{i=1}^{N_F} h_i^2 = \sum_{j=1}^{N_G} \sum_{i=1}^{N_{G_j}} \left\{ (h_{FG_j,i} - h_{G_j})^2 + h_{G_j}^2 \right\} = \sum_{j=1}^{N_G} \sum_{i=1}^{N_{G_j}} (h_{FG_j,i} - h_{G_j})^2 + N_{G_j} \sum_{j=1}^{N_G} h_{G_j}^2 \quad (25)$$

and dividing by  $N_F$

$$CH_L = \frac{1}{N_F} \sum_{j=1}^{N_G} \sum_{i=1}^{N_{G_j}} (h_{FG_j,i} - h_{G_j})^2 + \frac{N_{G_j}}{N_F} \sum_{j=1}^{N_G} h_{G_j}^2 \quad (26)$$

and again, if all groups are the same size or (12) holds,

$$CH_L = \frac{1}{N_F} \sum_{j=1}^{N_G} \sum_{i=1}^{N_{G_j}} (h_{FG_j,i} - h_{G_j})^2 + DH_L \quad (27)$$

and regardless of the first term on the right, which is always positive, shows that  $DH_L \leq CH_L$ . Gy states that the first term is the average constitutional heterogeneity of the groups.

So the magnitude of the  $DH$  is capped by the constitutional heterogeneity when all groups have the same number of particles which, as stated above, precludes the groups having significantly different size distributions and being of similar mass or volume as they would be if the groups correspond to correctly extracted increments from a moving stream or a static zero- or one-dimensional lot. The same cap may also exist depending on the behaviour of the terms that don't vanish when groups don't have the same number of particles.

Segregation by size is perhaps the first and most obvious type of particle segregation that is encountered.

Following Gy further, he defines the grouping factor,  $\gamma$  as

$$\gamma = \frac{N_F - N_G}{N_G - 1} \approx \frac{N_F}{N_G} - 1 ; N_G \gg 1 \quad (28)$$

and this is of the order of the number of particles in a group which can be envisioned as the number of particles in a potential increment, the groups corresponding to potential increments within the lot. This number is potentially HUGE. Gy suggests that the minimal  $DH$  is given by

$$DH_{L \min} = \frac{CH_L}{1 + \gamma} \quad (29)$$

which means that it is potentially zero. The maximal  $DH$  is of course the  $CH$ . He states that this maximum is achieved when the composition of all groups is *homogeneous*. This can be achieved, as previously deduced, when each group contains only one particle or when all particles in a group carry the same critical analyte concentration. He suggests that the maximal distributional heterogeneity can be achieved when, simultaneously

- the material under scrutiny is perfectly liberated (all particles consist of a single mineral phase)
- the various minerals are perfectly segregated
- the particles are grouped according to their mineral composition



and the groups carry the same number of particles, so that the relationship developed between  $DH$  and  $CH$  is valid.

Let us go back to the original definition of the distributional heterogeneity

$$DH_L = \sigma^2(h_{G_j}) = \frac{1}{N_G} \sum_{j=1}^{N_G} h_{G_j}^2 = \frac{N_G}{a_L^2 M_L^2} \sum_{j=1}^{N_G} (a_{G_j} - a_L)^2 M_{G_j}^2 \quad (30)$$

and that for the constitutional heterogeneity

$$CH_L = \sigma^2(h_i) = \frac{1}{N_F} \sum_{i=1}^{N_F} h_i^2 = \frac{N_F}{a_L^2 M_L^2} \sum_{i=1}^{N_F} (a_{F_i} - a_L)^2 M_{F_i}^2 \quad (31)$$

and do some arithmetic with some simple cases.

A good case is a binary mixture of two minerals with different densities and different particle sizes. The two minerals are segregated and grouped. The  $DH$  is then calculated as

$$DH = 2 \times \left[ \left( \left( \frac{a_{G_1} - a_L}{a_L} \right) \times \frac{M_{G_1}}{M_L} \right)^2 + \left( \left( \frac{a_{G_2} - a_L}{a_L} \right) \times \frac{M_{G_2}}{M_L} \right)^2 \right] \quad (32)$$

$$CH = (N_{G_1} + N_{G_2}) \left[ N_{G_1} \left( \left( \frac{a_{F_1} - a_L}{a_L} \right) \times \left( \frac{M_{F_1}}{M_L} \right) \right)^2 + N_{G_2} \left( \left( \frac{a_{F_2} - a_L}{a_L} \right) \times \left( \frac{M_{F_2}}{M_L} \right) \right)^2 \right] \quad (33)$$

Let's take the case in Table 1 and carry out a calculation. Further, we can vary the number of particles of the Phase 1 and see what happens to the values of the  $CH$  and  $DH$ . For the conditions in the table the calculation follows.

**Table 1. Heterogeneity Calculation Example (particles are all taken to be cubes)**

Phase 1	Value	Unit
density	5	g/cm <sup>3</sup>
size	1	cm
analyte conc	0.3	
number of particles	50	
particle mass	5	g
group mass	250	g
Phase 2		
density	2.6	g/cm <sup>3</sup>
size	2	cm
analyte conc	0.075	
number of particles	20	
particle mass	20.8	g
group mass	416	g
Lot		
total particles	70	
analyte conc	0.159	
total mass	666	g
$DH$		
from Phase 1	0.1095	
from Phase 2	0.1095	
total	0.4378	
$CH$		
from Phase 1	0.002189	
from Phase 2	0.005473	
total	0.5363	
ratio $DH/CH$	0.816	
gamma	68	

$$DH = 2 \left[ \left( \left( \frac{0.3 - 0.159}{0.159} \right) \times \frac{250}{666} \right)^2 + \left( \left( \frac{0.075 - 0.159}{0.159} \right) \times \frac{416}{666} \right)^2 \right] \quad (34)$$

$$= 2[0.1095 + 0.1095] = 0.4378$$

$$CH = (50 + 20) \times \left[ 50 \left( \left( \frac{0.3 - 0.159}{0.159} \right) \times \left( \frac{5}{666} \right) \right)^2 + 20 \left( \left( \frac{0.075 - 0.159}{0.159} \right) \times \left( \frac{20.8}{666} \right) \right)^2 \right] \quad (35)$$

$$= 70 \times [0.002189 + 0.005473] = 0.5363$$

The calculations carried out for a range of particle numbers in Phase 1 are plotted in Figure 1. When there are 20 particles

in each phase, the  $DH$  is indeed equal to the  $CH$  and because we have segregated according to phase and the groups are homogeneous, we have maximal  $DH$  in that the  $DH$  equals the  $CH$ .

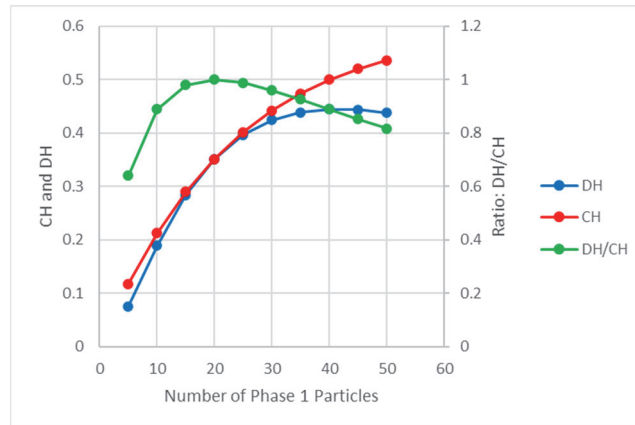

**Figure 1. Variation of  $DH_L$  and  $CH_L$  for the mixture considered in Table 1, with additional variation of the number of particles in Phase 1.**

A case of some interest to gold miners and processors is one in which we have relatively fine gold mixed with barren solids of a larger size. Consider 50 micron gold mixed with 150 micron barren material taken to have a density  $2.6 \text{ g cm}^{-3}$ . The particles will be taken to have a shape factor of 0.5. For 250 gold particles in a nominal 30 g sample, the grade is 9.67 g/t and there are  $7 \times 10^6$  barren particles. The  $DH$  and  $CH$  are calculated as follows.

$$DH = 2 \left[ \left( \left( \frac{1 - 9.67 \times 10^{-6}}{9.67 \times 10^{-6}} \right) \times \frac{0.000297}{30.71} \right)^2 + \left( \left( \frac{0 - 9.67 \times 10^{-6}}{9.67 \times 10^{-6}} \right) \times \frac{30.71}{30.71} \right)^2 \right] \tag{36}$$

$$= 2[0.99998 + 0.99998] = 3.9999$$

$$CH = (7.0 \times 10^6 + 250) \times \left[ \begin{aligned} &250 \left( \left( \frac{1 - 9.67 \times 10^{-6}}{9.67 \times 10^{-6}} \right) \times \left( \frac{1.188 \times 10^{-6}}{30.71} \right) \right)^2 + \\ &7.0 \times 10^6 \left( \left( \frac{0.0 - 9.67 \times 10^{-6}}{9.67 \times 10^{-6}} \right) \times \left( \frac{4.39 \times 10^{-6}}{30.71} \right) \right)^2 \end{aligned} \right] \tag{37}$$

$$= 7.0 \times 10^6 \times [0.0039999 + 1.43 \times 10^{-7}] = 28001.5$$

We see in this case that the  $DH$  is very small compared to the  $CH$  and that the magnitude of  $CH$  is governed largely by the gold phase. Note that here also we have two groups of liberated material but the  $DH$  is very small compared to the  $CH$ . There is clearly more to this issue of constitutional and distributional heterogeneity than is apparent at first glance.

To complete Gy's linking of the  $DH$  and  $CH$ , we consider his definition of a segregation factor,  $\xi$ , as

$$DH_L = \frac{1 + \gamma\xi}{1 + \gamma} CH_L = (1 + \gamma\xi) \frac{N_G - 1}{N_F - 1} CH_L \tag{38}$$

He states that  $0 \leq \xi \leq 1$  with the maximal value applying when the material is perfectly segregated. In the case of the gold example, using  $\gamma$  as given by (28), we have  $\gamma = N_F - 2$  as we have two groups

$$DH_L = (1 + \xi(N_F - 2)) \frac{1}{N_F - 1} CH_L \tag{39}$$

$$= \left( \frac{1}{N_F - 1} + \xi \left( \frac{N_F - 2}{N_F - 1} \right) \right) CH_L$$

and since  $N_F$  is very large,

$$DH_L \approx \xi CH_L \tag{40}$$

and the two groups are liberated and separate, so we would expect  $\xi = 1$ , but  $DH_L$  is very small.

It must be emphasised at this point that Gy's analysis corresponds to what is referred to in the statistical literature as a *non-parametric* analysis. He has made no assumptions in regard to the statistical distribution of particle grades or sizes, except insofar as he has considered the choice of groups that are homogeneous. It may be that to progress further, it will be necessary to bring in some statistical distribution concepts.

Chapter 20 of Gy<sup>1</sup> is concerned with the development of the discrete selection model. This chapter is rather heavy-going but what can be taken away from the development is that the final results are based on particles and units being selected with a uniform probability. Gy states at 20.5.2 that for 'correct' sampling, the expected mass of a sample is  $P$  times the mass of the lot, where  $P$  is the selection probability. This uniformity of mass makes the samples very similar.

The development leads to the conclusion that the selection of particles leads to the sampling variance being related to the  $CH$  of the material and selection of groups leads to the sampling variance being related to the  $DH$ . But it must be recalled that the  $CH$  to  $DH$  link is predicated by groups containing the same numbers of particles. This is a substantial assumption

but seems to be valid under the definition of correct sampling if the material is not substantially segregated. The final result of the development is the definition of the variance due to  $DH$  being related to the variance due to  $CH$  by the relationship

$$\sigma_{GE}^2 = \gamma \xi \sigma_{FE}^2 \quad (41)$$

where we recall that the value of the grouping factor  $\gamma$  is of order of the number of particles in a group, allowing the variance due to grouping to be much larger than the variance due to the fundamental error. However we note from Pitard<sup>3</sup> that the experience of Gy was that the product  $\gamma \xi$  tended to be about unity, so that the fundamental variance plus the grouping and segregation variance is double the fundamental variance.

## An Alternative Approach to Quantifying Distributional Heterogeneity

Gy makes considerable appeal to the mechanically correct sampling of particulate materials from a flowing stream or stationary lot, be it zero- or one-dimensional. In this he considers the use of a sampling tool that can be used to define potential increments from the lot. In the case of a flowing stream, we have the cross-stream sampler which effectively cuts a swath of material from the conveyor belt as the solids fall off the end of the belt. One can also consider the fundamental concept of stopped belt sampling off a conveyor or 'ribbon' sampling from a lot that has been spread out in a linear manner on a surface with a more or less constant mass per unit length.

While we usually consider the mass flow along a belt, it is also relevant to consider the volumetric flow along a conveyor belt. If the flow is coming from a feeder that has a device shaping the flow on the belt such as a gate at the outlet of a feeder from a bin, the flow will tend to be a constant volume flow and the sampling tool will cut a specific volume from the flow as an increment. This is certainly true in stopped belt sampling.

Gy's sampling theory has some significant constraints under it, as illustrated by the assumptions needed to connect  $CH$  and  $DH$ . It is possible to remove the constraints if we will admit to a parametric development of sampling theory. The author<sup>4,5</sup> has made such a development that is in agreement with Gy's result for the fundamental sampling variance (error). This alternative development is based on the concept that when a well-mixed heterogeneous material is sampled in a zero- or one-dimensional manner, the number of particles of any one type that arrive in an increment follows a Poisson distribution with an expected value derived from the properties of the lot. With the concept of the material being laid out on a conveyor belt and flowing at a constant mass flow rate, this assumption corresponds to the particles of any one type being placed on the belt in a totally random manner without spatial constraints. Their time of arrival at the end of the belt is a Poisson process. This situation clearly corresponds to Gy's selection of particles by number. We find that the fundamental sampling variance based on this conceptualisation agrees exactly with Gy's results. The new approach allows sampling theory to be taken further because we can use the properties of the Poisson distribution to calculate the full sampling distribution for a material if the size and composition distributions of the particles are known or can be reasonably assigned.

So perhaps it is legitimate to explore a variation of this conceptualisation of correct sampling that led to agreement with Gy's work. In the same way as Gy's did, we will consider the potential increments taken from the flow as 'units' having particular properties.

So what happens to our sampling scenario when the increments are defined volumetrically? First of all, their expected mass will no longer have to be constant as at more or less constant void fraction, the increment mass will reflect the mean density of the particles. It will also be possible to have increments that have different particle size distributions.

To explore this issue further, let us imagine sampling a set of groups of particles which have been made up of single mineral species. We will take the mass fraction of the  $i^{\text{th}}$  particle type in the lot to be  $z_i$  with a density  $\rho_i$  and some size distribution  $g_i(d)$ . Consider that the groups are laid out in a row which has a constant width and each particle class occupies a length fraction  $q_i$  in the direction perpendicular to the width of the layout. One might imagine that these are arranged on a conveyor belt so that the depth of each class is the same.

Next, we have to consider what the bulk density of the sections on the belt might be. If the particle size distributions were all the same, the void fraction on each class would tend to be the same, but the bulk density would be proportional to the density of the particles in the class. With a void fraction  $\varepsilon_i$  the bulk density for the  $i^{\text{th}}$  class would be

$$\bar{\rho}_i = (1 - \varepsilon_i) \rho_i \quad (42)$$

For unit width and depth of the classes, the fraction of the length occupied by the  $i^{\text{th}}$  class will be, for a total number of classes  $M_r$

$$q_i = \frac{\frac{z_i}{\bar{\rho}_i}}{\sum_{j=1}^{M_r} \frac{z_j}{\bar{\rho}_j}} \quad (43)$$

We can imagine that multiple strips of the classes are laid out in a random order so that there are many strips of the classes along the belt.

Now, if this belt were moving and we were to carry out a 'sampling experiment' taking a finite number,  $N$ , of *small* increments at random points in time, the number of times a given class was collected would follow a multinomial distribution. We will simplify the situation a bit by taking the probability of interception of increments consisting of adjacent particle classes to be zero. This could be taken into account, but this simplifying assumption makes the results easier to see. With small increments, the probability of intercepting more than one particle type is reduced.

The sampling tool will be taken to collect equal volumes of particles into each increment; this is analogous to 'stopped belt' sampling of a flow on a conveyor with a constant bed depth. The increment volume can be taken to be a volume  $\delta$ . The mass of this increment is then  $\delta\bar{\rho}_i$  so it carries a mass of target analyte of  $a_i\bar{\rho}_i\delta$  where  $a_i$  is the mass fraction of the target analyte in the  $i^{\text{th}}$  class.

The number of times that the  $i^{\text{th}}$  class is 'hit',  $R_i$ , is a multinomial random variable. Denoting the number of hits on the  $i^{\text{th}}$  class in one realisation of the sampling experiment as  $r_i$ , the sample composition for the experiment is,

$$a_s = \frac{\sum_{i=1}^{M_r} a_i \bar{\rho}_i r_i \delta}{\sum_{j=1}^{M_r} \bar{\rho}_j r_j \delta} \quad (44)$$

The expected value of  $R_i$  is  $Nq_i$  when the number of increments taken is  $N$ . The expected value of the sample assay is then

$$\begin{aligned} E\{A_s\} &= \frac{\sum_{i=1}^{M_r} a_i \bar{\rho}_i q_i \delta}{\sum_{i=1}^{M_r} \bar{\rho}_i q_i \delta} \\ &= \frac{\sum_{i=1}^{M_r} a_i z_i}{\sum_{i=1}^{M_r} z_i} \\ &= a_L \end{aligned} \quad (45)$$

so the sampling is unbiased to a first approximation. Note that when reference is made to a random variable, an upper case letter is used to denote the random variable and the corresponding lower case letter is used denote a realisation of that random variable.

To find the variance of the sample analyte content, the usual rule of propagation of variance is used so that

$$\text{var}\{A_s\} = \sum_{i=1}^{M_r} \left( \frac{\partial A_s}{\partial R_i} \Big|_{E\{R\}} \right)^2 \text{var}\{R_i\} + \sum_{i=1}^{M_r} \sum_{j=1, j \neq i}^{M_r} \frac{\partial A_s}{\partial R_i} \Big|_{E\{R\}} \frac{\partial A_s}{\partial R_j} \Big|_{E\{R\}} \text{cov}\{R_i, R_j\} \quad (46)$$

From the properties of the multinomial distribution, the variance of  $R_i$  is

$$\text{var}\{R_i\} = Nq_i(1 - q_i) \quad (47)$$

and the covariance between the number of hits is

$$\text{cov}\{R_i, R_j\} = -Nq_i q_j \quad (48)$$

The partial derivatives evaluated at the expected values of the number of hits can be shown to be

$$\frac{\partial A_s}{\partial R_i} \Big|_{E\{R\}} = \frac{\bar{V} \bar{\rho}_i}{N} (a_i - a_L) \quad (49)$$

and

$$\bar{V} = \sum_{i=1}^{M_r} \frac{z_i}{\bar{\rho}_i} \quad (50)$$

is the bulk specific volume of the solids (bulk volume of unit mass of solids mixture). The variance is then

$$\begin{aligned} \text{var}\{A_s\} &= \sum_{i=1}^{M_r} \frac{\bar{V}^2 \bar{\rho}_i^2}{N^2} (a_i - a_L)^2 Nq_i(1 - q_i) \\ &\quad - \sum_{i=1}^{M_r} \sum_{j=1, j \neq i}^{M_r} \frac{\bar{V}^2 \bar{\rho}_i \bar{\rho}_j}{N^2} (a_i - a_L)(a_j - a_L) Nq_i q_j \end{aligned} \quad (51)$$

We write the last term as

$$\sum_{i=1}^{M_r} \sum_{j=1, j \neq i}^{M_r} \frac{\bar{V}^2 \bar{\rho}_i \bar{\rho}_j}{N^2} (a_i - a_L)(a_j - a_L) Nq_i q_j = \sum_{i=1}^{M_r} \sum_{j=1}^{M_r} \frac{\bar{V}^2 \bar{\rho}_i \bar{\rho}_j}{N^2} (a_i - a_L)(a_j - a_L) Nq_i q_j - \sum_{i=1}^{M_r} \frac{\bar{V}^2 \bar{\rho}_i^2}{N^2} (a_i - a_L)^2 Nq_i^2 \quad (52)$$

The first term on the right can be split as

$$\begin{aligned} \sum_{i=1}^{M_r} \sum_{j=1}^{M_r} \frac{\bar{V}^2 \bar{\rho}_i \bar{\rho}_j}{N^2} (a_i - a_L)(a_j - a_L) Nq_i q_j &= \frac{\bar{V}^2}{N} \sum_{i=1}^{M_r} \bar{\rho}_i (a_i - a_L) \frac{z_i}{\bar{\rho}_i \bar{V}} \sum_{j=1}^{M_r} \bar{\rho}_j (a_j - a_L) \frac{z_j}{\bar{\rho}_j \bar{V}} \\ &= \sum_{j=1}^{M_r} \bar{\rho}_j (a_j - a_L) \frac{z_j}{\bar{\rho}_j \bar{V}} \frac{\bar{V}}{N} \sum_{i=1}^{M_r} z_i (a_i - a_L) \\ &= 0 \end{aligned} \quad (53)$$

Each of the sums equate to zero.

Then

$$\begin{aligned}\text{var}\{A_S\} &= \sum_{i=1}^{M_T} \frac{\bar{V}^2 \bar{\rho}_i^2}{N^2} (a_i - a_L)^2 N q_i (1 - q_i) + \sum_{i=1}^{M_T} \frac{\bar{V}^2 \bar{\rho}_i^2}{N^2} (a_i - a_L)^2 N q_i^2 \\ &= \sum_{i=1}^{M_T} \frac{\bar{V}^2 \bar{\rho}_i^2}{N^2} (a_i - a_L)^2 N q_i \\ &= \frac{\bar{V}}{N} \sum_{i=1}^{M_T} z_i \bar{\rho}_i (a_i - a_L)^2\end{aligned}\quad (54)$$

This result shows that the variance due to small scale particulate heterogeneity does not depend on particle masses (or volumes) in the same way as the fundamental sampling variance of the sampled material and that the variance is inversely proportional to the number of increments collected which corresponds to Gy's statement that taking lots of small increments is *the* way to defeat the variance due to grouping and segregation. Note also that if all the class bulk densities are similar then  $\bar{V} \bar{\rho} = 1$  and

$$\text{var}\{A_S\} \approx \frac{1}{N} \sum_{i=1}^{M_T} z_i (a_i - a_L)^2 \quad (55)$$

So now, what about the particle number dependence of the grouping factor  $\gamma$ ? Another way to write the fundamental sampling variance defined by Gy is

$$\frac{\sigma_{FE}^2(A_S)}{a_L^2} = \frac{1}{M_S} \sum_{i=1}^{M_T} z_i \rho_i v_i \left( \frac{a_i - a_L}{a_L} \right)^2 \quad (56)$$

where  $v_i$  is the typical fragment volume in the  $i^{\text{th}}$  particle class and  $M_S$  is the sample mass. This is Gy's result for the case of the lot mass much larger than the sample mass. So from (41),

$$\begin{aligned}\sigma_{GE}^2 &= N_{PI} \zeta \sigma_{FE}^2 \\ &= \frac{N_{PI} \zeta}{M_S} \sum_{i=1}^{M_T} z_i \rho_i v_i (a_i - a_L)^2\end{aligned}\quad (57)$$

where  $N_{PI}$  is the number of particles in a group (potential increment). Now, as the particle volumes go down, the number of particles in our 'groups' goes up, but this is appropriately balanced by the volume factor in the above expression for the fundamental sampling variance; volume down, numbers up. So as  $\sigma_{FE}^2$  goes down with decreasing particle volume, the number of particles goes up in inverse proportion to the volumes and we have a balance which might just come out close to the result in (54) or (55). Some simple exploration is appropriate.

Consider a very simple case in which all particles have the same mass,  $\bar{m}$ , but differing analyte contents. In such a case, the grouping and segregation variance can be written as

$$\begin{aligned}\sigma_{GE}^2 &= N_{PI} \zeta \sigma_{FE}^2 = \frac{N_{PI} \zeta}{M_S} \sum_{i=1}^{M_T} z_i \bar{m} (a_i - a_L)^2 \\ &= \frac{\zeta N_{PI} \bar{m}}{M_S} \sum_{i=1}^{M_T} z_i (a_i - a_L)^2\end{aligned}\quad (58)$$

But, with  $N_{PI}$  the number of particles in an increment,  $\bar{m} N_{PI} = \bar{m}_i$ , the mean mass of an increment, so

$$\frac{N_{PI} \bar{m}}{M_S} = \frac{\bar{m}_i}{M_S} = \frac{1}{N} \quad (59)$$

making

$$\begin{aligned}\sigma_{GE}^2 &= N_{PI} \zeta \sigma_{FE}^2 = \frac{N_{PI} \zeta}{M_S} \sum_{i=1}^{M_T} z_i \bar{m} (a_i - a_L)^2 \\ &= \frac{\zeta}{N} \sum_{i=1}^{M_T} z_i (a_i - a_L)^2\end{aligned}\quad (60)$$

To the extent of the simplification, the new relationship is in agreement with Gy's. Certainly, the order of magnitude is correct, and we recall that Gy assumed his increments were 'similar' and having similar numbers of particles in each 'group' or potential increment.

From a practical point of view, there is a need to be able to gauge the possible magnitude of grouping and segregation variance arising from *DH* compared to the fundamental sampling variance that is governed by *CH*. On the one hand, we have the relative variance due to constitutional or intrinsic heterogeneity (*IH*) given by

$$\frac{\sigma_{FE}^2(A_S)}{a_L^2} = \frac{1}{M_S} \sum_{i=1}^{M_T} z_i \rho_i v_i \left( \frac{a_i - a_L}{a_L} \right)^2 \quad (61)$$

which can be written in terms of the sampling constant  $K_S$

$$K_S = \sum_{i=1}^{M_T} z_i \rho_i v_i \left( \frac{a_i - a_L}{a_L} \right)^2 \quad (62)$$

as

$$\frac{\sigma_{FE}^2(A_S)}{a_L^2} = \frac{K_S}{M_S} \quad (63)$$

On the other hand

$$\frac{\text{var}_{GE}\{A_S\}}{a_L^2} = \frac{\bar{V}}{N} \sum_{i=1}^{N_I} z_i \bar{\rho}_i \left( \frac{a_i - a_L}{a_L} \right)^2 \quad (64)$$

for which we can define

$$D_S = \sum_{i=1}^{N_I} z_i \bar{V} \bar{\rho}_i \left( \frac{a_i - a_L}{a_L} \right)^2 \quad (65)$$

If we form the ratio of the variances and apply the segregation factor, we have

$$\begin{aligned} \frac{\text{var}_{GE}}{\sigma_{FE}^2} &= \xi \frac{M_S D_S}{N K_S} \\ &= \xi m_{inc} \frac{D_S}{K_S} \end{aligned} \quad (66)$$

where  $m_{inc}$  is the increment mass that is used to collect a total sample mass,  $M_S$ . We can also make the point that the sample mass collected will in practical terms be large enough to make the relative standard deviation due to IH somewhere around 2% or 0.02, so  $K_S/M_S = 4 \times 10^{-4}$  and then

$$\frac{\text{var}_{GE}}{\sigma_{FE}^2} = \xi \times 2.5 \times 10^3 \frac{D_S}{N} \quad (67)$$

Now, for the first example above with the values in Table 1 and zero voidage, we find  $D_S = 0.603$ . If we were to take say 50 increments in forming the sample, the ratio becomes

$$\begin{aligned} \frac{\text{var}_{GE}}{\sigma_{FE}^2} &= \xi \times 2.5 \times 10^3 \frac{0.603}{50} \\ &= 30.2 \xi \end{aligned} \quad (68)$$

This suggests that for the grouping and segregation variance to be comparable to the variance due to IH,  $\xi$  must be quite small. If it is not, the variance due to grouping and segregation will be larger than that due to IH. It is possible to calculate the value of the sampling constant for this material which comes out to 5.1 g. The sample mass to provide a 2% relative error is then 12.8 kg. The particles are 10 and 20 mm cubes and both phases carry significant analyte concentrations.

Moving to the second example with the fine gold, if we do the same calculations, the value of  $D_S$  is very large due to the low grade;  $D_S = 755986$ . The sampling constant is  $K_S = 0.123$  g. The sample mass that would be used to confine the relative standard deviation to 2% is 308 g. The variance ratio is now, having taken 50 increments

$$\begin{aligned} \frac{\text{var}_{GE}}{\sigma_{FE}^2} &= \xi \times 2.5 \times 10^3 \frac{7.56 \times 10^5}{50} \\ &= \xi \times 3.78 \times 10^7 \end{aligned} \quad (69)$$

This result suggests that the propensity for the gold ore to segregate is enormously greater than the simple material of example 1. We might conclude that materials containing a small quantity of a liberated high-grade phase is much easier to segregate than some other type of material and consequently also impossible to mix to a condition of particulate homogeneity.

## Discussion

Could this be a step towards better understanding and quantifying the grouping and segregation variance? We have the segregation factor,  $\xi$ , left with which we can adjust to move from particulate homogeneity to total segregation. But we have defined a maximal value of the grouping and segregation variance for total segregation that derives from consideration of sampling with increments of equal volume which is almost exactly true in mechanically correct sampling.

Size distribution effects can be taken into account with the introduction of a voidage factor for each particle class. The problem of dealing with the seemingly unmanageable number of particles in the increment has been more or less eliminated but finding a means of determining the segregation factor remains. This issue is akin to the issue that arose with the liberation factor before it was concluded that it was a concept that was hard to deal with and could in any event be removed when the size distribution of the target phase(s), liberated or not, could be estimated<sup>3,4,5</sup>.

Maybe this is what Gy had in mind; we shall not know as sadly he has passed away without further clarification of these concepts which are quite critical to his integration of sampling theory. His arguments concerning the grouping and segregation factors are 'hard work'. This argument does seem to encapsulate his remarks on segregation in terms of explaining the need to take many increments and his statement that the factor  $\gamma$  related to particle numbers. However, it still suggests that the variance can be rather large, but it does provide a mitigation of the dependence of  $\gamma$  on the number of particles.

To the author's knowledge there has been no quantitative analysis made previously in the sampling literature of Gy's development for segregation variance so there is no other literature that has a bearing on the analysis. We have only

Pitard's publications which follow Gy<sup>1</sup> closely. The author hopes that the step-wise analysis of Gy's derivation and the alternative approach to the derivation of a segregation variance based on the sampling of a mineral mixture by volume, which is more or less what happens with correct sampling equipment, will clarify thinking about the segregation variance and make the concept clearer to sampling practitioners. The new derivation does not solve the problem of the practical estimation of the sampling variance but illustrates what a state of total segregation is and hopefully permits the sampling community to better conceptualise/visualise the spectrum of states of segregation that can exist in practice.

## ORCID iDs

Geoffrey Lyman: <https://orcid.org/0000-0001-7570-9223>

## References

1. P. Gy., Sampling of Particulate Materials, Elsevier, 1982
2. F. F. Pitard, Pierre Gy's Sampling Theory and Sampling Practice, Volume 1, CRC Press, 1989
3. F. F. Pitard, Theory of Sampling and Sampling Practice, 3<sup>rd</sup> edition, CRC Press, 2019
4. G. J. Lyman, Theory and Practice of Particulate Sampling; an Engineering Approach, Materials Sampling & Consulting, Brisbane, 2019, Chapter 4.
5. G.J. Lyman, Mathematical developments in particulate sampling theory, P M Gy Oration, Ninth World Conference on Sampling and Blending, Beijing, China May 2019

# POSTERS





## The process of production certified reference materials for silicon industry

J. Anyszkiewicz<sup>a</sup>, T. Gorewoda<sup>a</sup>, J. Kostrzewa<sup>a</sup>, E. Jamroz<sup>a</sup>, Gro Eide<sup>b</sup>, K. Blandhol<sup>b</sup>, A.Y. Guldhav<sup>b</sup>, A. Toverød<sup>b</sup>, H. Teisrud<sup>b</sup>, V. Gengatharan<sup>b</sup>, A. Storesund<sup>b</sup>

<sup>a</sup>Lukasiewicz Research Network – Institute of Non-Ferrous Metals, Sowinskiego 5, 44-100 Gliwice, Poland. E-mail: jacek.anyszkiewicz@imn.lukasiewicz.gov.pl

<sup>b</sup>Elkem Technology, PO Box 8040 Vaagsbygd, N 4621 Kristiansand, Norway. E-mail: Kjell.blandhol@elkem.com

**Silicon is the element of significant importance – including the production of electronic devices, solar panels and metallurgical alloys. Silicon materials producers must keep strict quality control of their raw materials and products. Modern and innovative silicon production line requires high quality analytical information about chemical composition – for this purpose instrumental methods are commonly used. Correctness of the results obtained with these methods must be verified using materials of well-know composition, traceable to SI units, confirmed by the certificate. These materials are called certified reference materials (CRM).**

**In response to the market needs, ELKEM (Norway) – the world’s leading silicon producer, together with ŁUKASIEWICZ – Institute of Non-Ferrous Metals (Poland) - an experienced CRMs producer, started the SILREF project, which consist of production of 8 CRMs for silicon material: metal silicon, ferrosilicon and microsilica.**

**Development of new CRMs consist of several stages: production of material with planned composition, homogenization via grinding, sieving, and mixing, homogeneity and stability testing, characterisation, and certification. Sampling is part of almost every one of these steps. The choice of the right sampling scheme has a significant impact on the final quality of the produced CRMs. Homogeneity of powder type CRMs and its estimated uncertainty makes important contribution to the total uncertainty of the reference values.**

**After homogenization and dividing the material into the 100 mL jars, 200 to 700 single units were obtained - depending on the material. In this case it is important to determine the homogeneity between the units and inside them. This was performed in accordance to the rules of ISO Guide 35:2017 “Reference materials — Guidance for characterization and assessment of homogeneity and stability”. 10 random single units from every material was selected. Then, three samples from different place were taken from each unit. All parameters planned for certification (element concentrations, loss of ignition etc.) require analysis for homogeneity, stability and quantitative determination. The obtained data were used for the statistical evaluation of homogeneity based on the ANOVA test. The determined homogeneity was taken then for further calculations of total uncertainty.**

**The determination of homogeneity, stability and characteristics is accompanied by a large number of analytical test and statistical calculations that lead to determination of the final reference’s composition values with their expanded uncertainty.**

### ORCID iDs

J. Anyszkiewicz: <https://orcid.org/0000-0002-3918-1684>

## Estimating the heterogeneity invariant using size-density classes – the case of contaminated soil and complex materials

Jean-Sébastien Dubé<sup>a</sup> and Kim H. Esbensen<sup>b</sup>

<sup>a</sup>Laboratory for geotechnical and geoenvironmental engineering, École de technologie supérieure, 1100 rue Notre-Dame ouest, Montréal, QC, Canada, H3C 1K3. E-mail: [jean-sebastien.dube@etsmtl.ca](mailto:jean-sebastien.dube@etsmtl.ca)

<sup>b</sup>Owner and Consultant, KHE Consulting, Copenhagen, DK E-mail: [khe.consult@gmail.com](mailto:khe.consult@gmail.com)

For the important material class of aggregate mixtures comprised by both analyte-enriched and *analyte-coated* particles, Gy's classical  $s^2(\text{FSE})$  formula has often been reported to yield estimates of the fundamental sampling variance *greater* than the empirically estimated sampling variance. Which, however, is physically impossible according to the tenets of the Theory of Sampling (TOS), both physically and logically, since the fundamental sampling variance is, by definition, the minimum sampling variance remaining after all other sources of sampling errors have been eliminated. This situation has for many decades hindered rational use of the Theory of Sampling for this kind of complex systems. We here focus on contaminated soil as a typical illustrative example of great interest, as well as more generally in the field of environmental site assessment. This uncomfortable situation is exacerbated by the fact that sampling in these fields is still, after 70+ years of TOS, largely conducted by grab sampling, which assuredly lead to significant uncertainty and bias.

However, there is a solution to this at first sight 'intractable' problem to be found, specifically within TOS. In some of his earlier publications, Gy developed a variant the  $s^2(\text{FSE})$  formula based on consideration of both size- and density classes, but quickly dismissed this approach as being inapplicable to « the metal, mining, and processing industries [...] due to the unusual density contrast between the components » typical of matrices sampled in these fields. This size-density class variant was consequently then left out of sampling awareness and literature for a long time.

We revisit herein development of the heterogeneity invariant on this basis and show this to represent a general option which can be adapted to distinct and specific matrices and analytes *beyond* the original restricted realm. As an example, a size-density class variant is applied to data from studies on sampling complex contaminated soils for which the use of Gy's classical formula yielded such 'impossible' estimates of  $s^2(\text{FSE})$  *larger* than empirical sampling variances by *several orders of magnitude*. This size-density class  $s^2(\text{FSE})$  variant now provides estimates for all cases and examples, which are systematically smaller than the empirical sampling variances, and thus in full accordance with the Theory of Sampling. This generalised approach is also applied with similar success to *controlled materials*, which were made to represent analyte-enriched and/or analyte-coated matrices, as used in recent studies on sampling bias and representativeness.

The results in our studies all show that it is not Gy's classical formula which was at fault when applied outside the traditional domains, e.g., to contaminated soils, it is that the critical assumptions behind the formula were broken, unwittingly, or worse, with blunt carelessness. In analyte-coated materials, or for mixed matrices, the original full size-density class-based formula now provides the proper starting point for developing TOS-compliant matrix-specific approaches on a much broader scale. With this new scope, analysts no longer must forego the revolutionary advantage of Gy's classical formula, i.e., the capacity to estimate the fundamental sampling variance *a priori*. Now, only at the cost of a pilot sampling stage, the augmented size-density class formula provides the analyst with the capacity to adapt sampling protocols also to the challenging task of taking on practically all natural systems *sesu lato*, however complex.

The full paper has been published in *Analytical Chemical Acta*, which can be downloaded at a click here: <https://www.sciencedirect.com/science/article/pii/S0003267021010539>

Dubé, J.-S. and K.H. Esbensen. 2022. Revisiting Pierre Gy's formula (TOS) - A return to size-density classes for applications to contaminated soils, coated particular aggregates and mixed material systems. *Analytica Chimica Acta*, 1193: 339227

### ORCID iDs

J.-S. Dubé: <https://orcid.org/0000-0003-4409-5470>

K.H. Esbensen: <https://orcid.org/0000-0001-6622-5024>

## Smart control of HVAC based on measurements of indoor radon concentration

---

M. Fromreide<sup>a</sup> and I. Henne<sup>b</sup>

<sup>a</sup>NORCE Norwegian Research Centre AS. E-mail: mafr@norceresearch.no

<sup>b</sup>NORCE Norwegian Research Centre AS. E-mail: inhe@norceresearch.no

---

**Sufficient ventilation is important for creating a healthy indoor environment in both households and larger buildings (schools, offices, shops, warehouses). As the cost of heating and ventilation in large buildings is very large, modern ventilation systems apply smart control for optimizing the energy consumption. The control is typically based on temperature and/or CO<sub>2</sub> levels, whereas other pollutants such as particulate microparticles and radon are not accounted for. Exposure to indoor radon is the second most important reason for lung cancer, with more than 200 000 cases estimated worldwide every year. The indoor radon concentration depends on many factors, from local geological conditions and weather, to building materials and natural and mechanical ventilation.**

**Together with the Norwegian company OBEO AS, NORCE has completed a study of the indoor radon concentration at a Norwegian primary school prone to high radon levels. The study includes continuous measurements of radon, CO<sub>2</sub> and temperature for multiple rooms for different use as well as data for the ventilation system. The aim for the project was to build knowledge for a larger research project, where the goal is to develop a control algorithm for HVAC systems which also takes radon levels into account.**

**An important challenge is to make accurate sensors for measuring radon continuously at an affordable price for implementation in complex buildings. Generally, sensors that can measure at high frequency with good accuracy is very expensive. Thus, developing algorithms and mathematical models to treat the data from low-cost sensors can be an adequate tool for large systems/buildings. One must also account for the positioning of the sensor. For instance, it is known that the radon concentration is better distributed in a room with mechanical ventilation than in a room without, making the position of the sensor important for better interpretation of measurement data. In the pre-project we have studied how the radon levels show large variations that are related to the ventilation operation and daily/weekly variations. The large variations show the need for a high sampling rate (minutes to hours) to capture the peaks in the concentration. We have also studied the rate of change in radon concentrations over time and have amongst discovered a noticeable delay from the start of ventilation until radon is effectively removed from the air. The rate of change is an important parameter for planning ahead and securing fresh air during the full period of presence whilst optimizing the energy cost.**

## X-ray Computed Tomography (XCT) for characterization of particulate materials

### heterogeneity: Embrace heterogeneity – create value with separation

---

C. Robben, A. Moslemiyekan and K. Esbensen

<sup>a</sup>SIX-S Consulting, Wedel, Germany. [chris.robben@six-s.com](mailto:chris.robben@six-s.com)

<sup>b</sup>KHE Consulting, Copenhagen, Denmark. [khe.consult@gmail.com](mailto:khe.consult@gmail.com)

---

**Value created by mineral beneficiation processes relies on physical separation (including flotation) of particles containing different grades of metals or minerals of economic interest. The value created is a direct consequence of exploiting heterogeneity as governed by the properties of the natural resource that is processed, most often starting by well-controlled size reduction processes, e.g. blasting, crushing and grinding. These are usually applied in a stepwise fashion before the separation stage exploiting the liberated mineral(s) of economic interest.**

**While material heterogeneity usually is a property that must be managed (reduced) by mixing and blending to stabilize sampling and optimize extraction processes, it can also be the fundament for creating value by first increasing liberated heterogeneity to allow effective sorting to come into play. To calibrate value-adding physical separation processes it is necessary to be in complete control of material heterogeneity, as part of characterization of the original natural resource. Optimal physical separation is based on relevant sampling, Theory of Sampling (TOS). However, this is currently done with labour intensive processes conducted with highest precision but notably most often only using small sample masses, often leaving accuracy be the wayside. This contribution shows that TOS is a prime factor, as is representative heterogeneity characterization, necessary for optimizing mineral beneficiation processes.**

## The “Gandalf” soil sampling project at a former industrial site in Copenhagen, Denmark: evaluating soil classification reliability

Bo Svensmark<sup>a</sup>, Peter Mortensen<sup>b</sup>, Nemanja Milosevic<sup>c</sup> and Jan H. Christensen<sup>d</sup>

<sup>a</sup>Department of Plant and Environmental Sciences, University of Copenhagen, Thorvaldsensvej 40, 1871, Frederiksberg C, Denmark, E-mail: [svensmark@plen.ku.dk](mailto:svensmark@plen.ku.dk)

<sup>b</sup>Research and Development at Eurofins Environment Denmark, Ladelundvej 85, DK-6600 Denmark, E-mail: [pm@eurofins.dk](mailto:pm@eurofins.dk)

<sup>c</sup>MOE A/S engineering consultancy, Buddingevej 272, 2680, Søborg, Denmark, E-mail: [nmi@dmr.dk](mailto:nmi@dmr.dk)

<sup>d</sup>Department of Plant and Environmental Sciences, University of Copenhagen, Thorvaldsensvej 40, 1871, Frederiksberg C, Denmark, E-mail: [ich@plen.ku.dk](mailto:ich@plen.ku.dk)

Handling and transport of contaminated soil from industrial sites in Denmark requires classification based on concentrations of selected metals and organic contaminants. Reliable soil classification is needed for defensible remedial decision-making. Today's sampling process in Denmark is based on grab sampling of prescribed standard volumes of soil; 30 tons is typically used as the basic sampling Decision Unit. Soil classification follows a number of varying systems, but classification into five classes (class 0 to class 4) based on analytical results from sub-samples of 50 g is the most common. In this study we investigate the sampling uncertainty obtained by sampling of > 1800 samples at a former industrial site in Copenhagen, Denmark. The aim of the study was to conduct a critical assessment of the current sampling strategy by determination of soil classification errors obtained for duplicate primary samples collected from the same truck-load of soil, but with different distances from the original primary sample. It is also discussed which contaminants are the major parameters responsible for final soil classification designations. The original primary samples for the soil classification were taken at the centre of a 7 x 7 m grid for every 33 cm to a depth of 1 m or 3 m. In addition - for approximately half of the positions - samples were taken at a distance of 1, 2 or 3 m from the original sample. The classifications for the original samples were compared to the classifications for the additional samples in the same Decision Unit (7 x 7 x 0.33 m box) and from duplicate original samples. The results show that at least 50 % of all samples were misclassified, 20 % were misclassified by two or more classes. This study demonstrates that the risk of misclassification is highest for less mobile parameters, metals and PAHs compared to the volatile organic solvents.

### ORCID iDs

Bo Svensmark: <https://orcid.org/0000-0003-0430-6181>

Peter Mortensen: <https://orcid.org/0000-0002-7290-8080>

Nemanja Milosevic: <https://orcid.org/0000-0001-7226-1910>

Jan. H. Christensen: <https://orcid.org/0000-0003-1414-1886>

### References

1. B. Svensmark, P. Mortensen, Nemanja Milosevic and Jan H. Christensen, *The “Gandalf” soil sampling project at a former industrial site in Copenhagen, Denmark: evaluating soil classification reliability*, *SpectroscopyEurope*. 33, 37-47 (2021). <https://doi.org/10.1255/sew.2021.a29>

## Sample Preparation according to Ian Devereux: an unofficial guide

---

S. Russell<sup>a</sup>

<sup>a</sup>Melbourne, Australia. E-mail: [srussell@block10.com.au](mailto:srussell@block10.com.au)

---

This is a summary of the concepts, ideas, and experiences of Ian Devereux, recorded as a reference in the late noughties shortly prior to his retirement. His 14 typed pages summarised his insights after 40 years of leading and growing Rocklabs into the world leader in Sample Preparation Equipment design, manufacture, and supply. This mixture of facts, observations and opinions are offered without reference to complex technical analysis. The author intends this paper as a tribute to one of the pioneers of our industry and hopes that it may be used as an accessible introduction to the concepts and importance of the field of Sample Preparation. In memory of Ian Devereux MSc, PhD, FNZIC, AMAusIMM (11 Feb 1940 – 25 April 2020).

Sample preparation is a very broad subject. If you try putting these two words into Google you get 579,000,000 entries! In our domain, we typically restrict the topic to include the minerals and metals industry which includes mineral exploration mining, smelting, refining and research.

Sample Preparation is the middle step in the process that covers taking the sample, preparing the sample and analysing the sample. It is vital for a good understanding of Sample Preparation that you also understand the procedures and processes of the other two activities. If everything is not done well, the result achieved will be of doubtful value.

It is very common for a laboratory to receive a sample for analysis without any knowledge or understanding of how the sample was taken and whether it is truly representative of the lot of material that it comes from. "We do the preparation and analysis. This is our responsibility. It is someone else's job to ensure the sample is a good one," are typical attitudes. In part they are correct, but a laboratory must be careful if they have been asked for a precise analysis on a sample that may not be representative and then an argument follows as to why the result is in error. Laboratories are often accused of mistakes when the real culprit is a poor sample. As designers and manufacturers, we need to do all we can to ensure the sample processing equipment is as representative as possible.

## COVID-19: Lessons for developing and commissioning new mining technologies`

---

S. Russell<sup>a</sup>

<sup>a</sup>Melbourne, Australia. E-mail: [steven.russell@southerninnovation.com](mailto:steven.russell@southerninnovation.com)

---

**For many of us in the regionally distributed and interconnected mining industries, the pandemic impacts were earlier and broader than most.**

**PDAC, the mining mega-convention that descends on Toronto each spring, started 2020 as per any other year, but by the end of the week the world had changed. Sanitiser bottles appeared on tables, elbow bumps replaced handshakes, and the airports on the trip home were a mix of caution and carnage; a sign of the new reality to which we had now entered.**

**COVID-19 had rapidly spread from being an isolated ‘Wuhan’ virus, and many projects still had field personnel undertaking commissioning and service activities. In the space of a week in March 2020, the focus shifted from urgently completing tasks to evacuating staff back to safety as expeditiously as practicable. Clients were generally supportive of such movements, with similar strategies playing out within their operations.**

**Movements were quickly constrained by pandemic restrictions, and the plane tickets, hotel beds and shipping containers were invariably prioritised for essential operations. Despite high opinions of our indispensability, we ceded priority in most jurisdictions to the public health response.**

**It was only once personnel were back safely in their home cities or in hotel quarantine, stakeholder meetings had been urgently convened across myriad not-yet-ubiquitous online platforms, and formal written correspondence had been exchanged flagging the start of the disruption, that the reality set in; how to continue and complete mining project installations on the opposite side of the continent or world, with operations and suppliers suspended or furloughed, and no certainty as to when personnel and equipment mobility may resume?**

**With very few precedents to draw upon in any of our working careers, the well-intended responses to these disruptions were varied in success, but in any case, will prove formative to how we act in future crises. Whilst we cannot predict with certainty when, where and how the next disaster will occur, it is incumbent on all to take the hard learned lessons of COVID-19 and have disaster response and recovery plans that are updated and reflect our real, lived experiences.**



## ISO 8685 Compliant Contractual Ship-Loading Export Facility: Bauxite Sampling Plant Process Design and Equipment Selection for Chemical Sampling.

W.P. Slabbert<sup>a</sup> and M. Nyokong<sup>b</sup>

<sup>a</sup>Email: [willems@multotec.com](mailto:willems@multotec.com)

<sup>b</sup>Email: [disen@multotec.com](mailto:disen@multotec.com)

The paper discusses the process design and mass balance for the minimum and maximum design case to illustrate the ISO 8685 compliance of a 2-year-running barge loading payment station sampling plant. The plant samples - 100 mm, export quality, bauxite material from a barge-loading conveyor delivering 10 kton/h at 5.4 m/s. The green field operation does not know the Coefficient of Variation or the Size Range Factor as required inputs to calculate the Number of Primary Increments and Minimum Gross Sample Mass required. Therefore, informed assumptions were made given performance data of a neighboring sampling system that is in operation for over a decade. Without the available variation and size factor data the ISO-compliant scheme design could not commence. Where this data is not available for green field projects, it poses a risk that plant designs may not be compliant where variabilities could exceed assumptions on the input parameters.

The system is designed for various barge carrying capacities with lot size in mass. Operational quality assurance however requires samples more frequently and therefore subplot periods are 4 hourly time based. ISO 8685 compliance is achieved with sample increments taken at maximum throughputs and barge sizes to determine the time-based interval. At reduced throughputs, the fixed time interval regime results in the minimum ISO requirements to be exceeded and tied in well with client overall quality incentives.

Primary sample increments from a tailored cross belt sampler are crushed automatically in the sampling plant to 25 mm and then to 6mm using two stages of double roll crushers. The sample is then subdivided through secondary and tertiary sampling to produce a composite 4-hourly chemical sample. The 4-hourly subplot samples are collected in an ergonomic 4-way carousel with each composite sample representing 1-hour barge loading production – allowing the client quality assurance insights into their blending facility performance.

**Keywords:** ISO 8685 compliant, Sampling Plant, mass-based lot, time-based sampling interval.

### Project Background

The client understood the importance of correct sampling as an important contributor to quality assurance of bauxite grade between port-and-buyer. Commercial payment terms were structured around ISO 8685: 1992<sup>1</sup> with specification of Aluminium and Silica grade maximum tolerable bias (MTB) levels. Compliance to ISO 8685 and sampling plant performance to sampling variance within the MTB levels are therefore important to defend commercial trade risks. The client identified the need for correct sampling and ensured that commercial trade conditions were written around the applicable commodity ISO sampling requirement. They did their part well, only to be let down by the executing engineering company and a Sampling Equipment Manufacturer (SEM) who proposed a single stage hammer sampler. Apart from mechanical design inadequacy, this single stage sampling system without comminution and subsampling would result in enormous composite sample masses forcing the operation to take too few sample cuts required for an ISO compliant sampling scheme. Thankfully, informed client technical adjudication role-players compared the single stage, primary sampler proposal against their experience with multi-stage sampling plants on iron ore, coal and manganese and probed the compliance of the offer with a different SEM. This SEM consulted and guided project stakeholders on: 1) sampling correctness, 2) adequate automated mechanical sampler design and 3) understanding the requirements for ISO compliance, given system parameters of particle top size, lot size, production throughputs and nomograms imbedded in the ISO standard that require crushing before subsampling to ergonomic sample sizes. However, increment variability and size range factor data were not known for the green field operation and sampling scheme design calculations could not be done. Under preliminary assumptions, the SEM explained that the primary sampler is only the first step into an overall sampling regime that requires a sampling plant infrastructure. Unknown system parameters would have to be obtained before the design can commence.

Further project constraints included production conveyors which were under construction and an onsite laboratory which was already built. SEM advice on sampling correctness of a cross stream primary sampler was explored but concluded that

existing conveyor designs and transfer tower heights did not allow for belt end crosscut samplers to be fitted at the head pulley. A feasibility study was conducted, with conceptual equipment designs from the SEM, to determine the techno-commercial project implications to install cross stream samplers. The anticipated project costs and reworks on existing infrastructure rendered this option to be unfeasible. Suitable positions were identified for installation of a primary hammer (cross belt) sampler, despite structural engineering challenges on existing conveyor stringer load allowances that would have to be overcome. Despite other ISO sampling standards prohibiting the use of cross belt samplers, ISO 8685<sup>1</sup> does not exclude hammer samplers from use in Bauxite sampling applications. The run of Mine (ROM) material is crushed down to -100 mm export size using Mineral Sizers which are promoted to generate less fines and more regular shaped product both of which are suitable characteristics for representative cross belt sampler applications. The laboratory equipment was already installed and imposed constraints on composite sample top size of 6mm and sample mass of less than 10kg.

The client's mandate to be recognized as a reliable bauxite supplier overcame the technical and commercial hurdles to install a multi-stage sampling system with cross belt primary sampler as a "compromise" to cross stream samplers which are better regarded by sampling purists.

The responsibility was set on the SEM to design and supply a multistage sampling system for commercial trade that complies to ISO 8685, overcomes the engineering constraints and delivers correct sampling results within the MTB limits.

## Literature Review.

Holmes (2010)<sup>2</sup> mentions that sampling must be given the necessary attention to produce representative samples for analyses. It should be noted that Holmes makes use of the word sampling not sampler, since a sampler is a piece of device, mechanical or not, that can be used to collect a sample from a moving stream or stationary lot. The word sampling is the science of collecting representative samples which includes, but is not limited to the sampler, number of increments the sampler takes, how the samples are collected, stored, and transported to the lab for analyses and ultimately how the samples are analyzed. It is important to understand that deviation from an ideal sampling scheme is a cumulation of incremental error contributions towards the total sampling error as defined by the Theory of Sampling (TOS). The degree of error accumulation and nature of the errors are ascribed to bias (accuracy deviation), precision (reproducibility) and ore variability. Therefore, the objective of any sampling system or protocol is to eliminate or minimize bias, standard deviation and minimize variance (Minnitt, 2007)<sup>3</sup>. Eliminating bias generating errors falls under the responsibility of the SEM. Where material variance information is available (i.e. in the form of a Nomogram), the SEM is also expected to design a sampling system that can sample the material variance to the required precision levels through sample increment frequency and sufficient sample mass. The nomogram information is not always available for the specific ore of concern, as a result, ISO standards are normally referred to as a guideline for sampling of various bulk commodities (Steinhaus & Minnitt, 2014)<sup>4</sup>. According to Steinhaus and Minnitt (2014)<sup>4</sup>, SEMs need to familiarize themselves with the critical aspects of each ISO standard which relates to the minimum number of increments and the minimum sample mass to be collected per lot, the minimum number of sub-increments per preceding increment, quality variations, precision levels achieved relative to the material nominal top size, etc.

Recent advances on practical mineral process sampling of damp bauxite is published (Lyman, 2019<sup>5</sup>) and useful to future bauxite sampling projects. The release of the book lagged the project design of this paper with a year and this paper did not benefit from the valuable recommendations.

### Mass versus time-based sampling and the weighting error

The Weighting Error is defined by TOS as the error that results when a sample increment weight is inconsistent despite consistent lot sizes (production weight intervals) it is supposed to represent - where the sampling rule of proportionality is not conserved. In the case of hammer samplers, the sampler can only sample the material loaded on the belt at the instance of increment extraction. Even if the cutter speed set point is changed in between consecutive increments, the sampling action will not result in a different sample increment weight because the hammer sampler will still sample the material burden on the belt (now only at different velocity through the stream). The increment mass extracted by a hammer sampler will only change if the velocity of the production conveyor it is sampling from changes and results in a lower loading (ton per meter) on the belt. If each hammer sample increment is intended to represent a constant production weight, where the sample cut is prompted by a cumulative weightometer input in a mass based scheme, there could be a discrepancy in the ratio of

sample increment weight over constant production weight, between consecutive increments. For this reason, hammer samplers can only be used on a time basis.

Cross stream samplers however, can be controlled over a defined range by varying frequency drives to change their cutter speed before a cut is initiated and then cut through the stream at that instantaneous speed set point. This possibility allows a cross stream sampler, running on a mass based sampling scheme, to adapt its cutter speed to spend more or less time through the stream and result in a constant ratio of sample increment weight over constant production weight. Cross stream samplers can be used in mass- or time-based sampling regimes. For use in time-based regimes, the cutter speed must be consistent between cuts at a fixed set point irrespective of instantaneous throughput.

## Theoretical design of the ISO compliant sampling scheme

### Known input parameters

The design heuristic for a compliant bauxite sampling system is explained by the ISO 8685 sampling standard<sup>6</sup>. The number of primary increments and the minimum gross (composite) sample mass are important design outputs from the ISO standard equations. The calculations require input variables for the parameters of the specific system being designed. The known input parameters for this system is listed in Table 1 below.

**Table 1. System design parameters.**

Parameter	Value	Units	Comments
MTB for Alumina content	±0.5	%	Measured as Al <sub>2</sub> O <sub>3</sub>
MTB for Silica content	±0.2	%	Measured as SiO <sub>2</sub>
Lot size	13	kton	The client requirements extend beyond a chemical sample per barge load (mass based) and requires quality assurance of the blending and reclaiming (quality control) operations. A time based hourly chemical sample is required over the 1.5-3.5 hour barge load duration.
Lot duration	4	h	
Sub-Lot duration	1	h	
Nominal particle top size	100	mm	Produced from a Mineral Sizer known for producing cubic shaped particles with minimal fines generation.
Particle density	2 680	Ton/m <sup>3</sup>	

### Unknown input parameters

The greenfield operation has not produced any sampling results and the following two inputs parameters are unknown. The increment variance ( $V_i$ ) is assumed to be 1.75. The sampling scheme design authority has access to a nearby operation's variance data from their more-than-a-decade operational sampling plant and can base this variance assumption on data from previous bias tests conducted at the preceding site. The assumption will have to be verified according to DS 3077 (2013<sup>7</sup>) against system produced data once the sampling plant is operational.

The coefficient of variation ( $C_v$ ) for Aluminium and Silica grades is assumed by the client to be 15% for this "homogenous ore" and verified against neighboring sampling plant data as a reasonable assumption. The assumption will have to be verified against system produced data once the sampling plant is operational.

### The risk of using unknown parameters into an inflexible plant design

Where data is not available, assumptions towards unknown input parameters required to design a compliant sampling scheme may be the designer's only option. The scheme design will dictate the equipment selection for the sampling plant. Once operational, the sampling plant must produce accurate results without bias. The accurate data from the sampling campaign will allow calculation of the variance parameters and the sampling scheme design must be verified for ISO compliance using the new variability data. The results may render the original sampling scheme non-compliant and larger sample weight and/or more frequent sampling may be required. It may also happen that production or in sampling plant crushers do not perform to their size reduction and large particles may have to be sampled. It is therefore important that the sampling equipment, crushers and plant throughout design capability be conservative on the first iteration and adaptable to accommodate the new throughput rates, sample weight and particle top size. Adaptability should come without major

modifications and capital cost. Designing green field sampling plants to meet (not exceed) minimum compliance requirements is a great risk if reliable variance data is not available. Where major plant upgrades to a new sampling plant must be done post-commissioning, capital is not likely to be approved resulting in undersized and underperforming sampling plants (white elephants) which the industry should not tolerate.

### Calculation of compliance requirements

The number of required primary sample increments (n) is calculated using the below equation from ISO 8685<sup>8</sup>.

$$n = \frac{V_I}{\sigma_s^2}$$

n is the number of primary increments

$V_I$  is the increment variance

$\delta_s^2$  is the desired sampling variance

The value for n is calculated to be 43.75 using  $V_I = 1.75$  and using the more stringent 0.2% silica ( $\text{SiO}_2$ ) sampling variance. Practically 44 increments for chemical assaying are required. The number of 44 increments for silica precision sampling transcends the requirement for Aluminium content sampling, at  $\pm 0.5\%$  precision, by factor 6 and exceed minimum compliance requirements.

The number of sampling units (k) cannot be calculated in the design phase with too many variables (variance of sampling, sample preparation, measurement, overall variance and number of replicable determinations) not known before the sampling plant is commissioned. The plant is rather designed to collect and analyze 4 off 1-hourly samples according to the client's quality assurance requirements around their blending operations. Without the necessary data, the number of sampling units is set to 4 without strict compliance to the ISO determination. The design decision will have to be verified against system produced data once the sampling plant is operational.

The minimum gross sample mass required to achieve the desired relative sampling error is determined using (ISO 8685<sup>9</sup>):

$$m_G = \left(\frac{C_V}{\sigma_s}\right)^2 \rho g D^3 \times 10^{-6}$$

$M_G$  is the minimum gross sample mass in kilogram

$C_V$  is the coefficient of variation between particles of the quality characteristic under investigation.

$\delta_s$  is the required relative sampling error (standard deviation).

$\rho$  is the particle density in  $\text{ton/m}^3$  (not bulk density).

g is the size range factor.

D is the nominal top size in millimeter of the ore in the Lot

The size range factor was calculated from the data obtained during production scale test runs performed by the production mineral sizer original equipment manufacturer. Test work was also conducted to determine the crushing efficiency of the in-plant sample preparation, double stage rolls crushers. The necessary PSD data of the crusher test work is listed in Table 1 below.

**Table 2. Crusher performance results at  $P_{95}$  and  $P_5$  and determination of size range factor (ISO 8685<sup>9</sup>).**

Sample Identification	D= $P_{95}$ (mm)	D' = $P_5$ (mm)	D/D'	Value for g
ROM production	100	3	33	0.25
After first stage double rolls crushing (within sampling plant)	25	1	25	0.25
Wet material After second stage double rolls crushing (within sampling plant)	4	<1	>4	0.25
Dry material After second stage double rolls crushing (within sampling plant)	9	<1	>6	0.25

The minimum gross sample mass is calculated by using parameter values listed above to be 3769 kg. After size reduction to  $P_{95} = 25$  mm,  $M_G$  decreases to 59 kg and at  $P_{95}=6$  mm reduces to 0.81 kg. It should be noted that the tabulated result for

secondary crushing test work of dry material ( $P_{95} = 9$  mm) was not used in the calculation because crusher design modifications are made to ensure that -6 mm material would be produced under both wet and dry operating conditions (this is a laboratory top size constraint). All PSD values used in the above table must be confirmed during performance testing of the plant and design parameters verified as actual performance data.

From the minimum gross sample mass, the increment mass is calculated to be  $MG/n = 3769/44 = 85.7$  kg.

The sample increment frequency is calculated as the lot duration divided by the number of primary increments required. For this system design, 44 increments must be taken in 4 hours' time which requires an increment every 5 minutes and 27 seconds.

For chemical sample compliance, the sampling plant must take a primary cut every 5 minutes and 27 seconds to total 44 increments over a 4-hour lot period. Each increment must have minimum mass of 85.7 kg. The total composite sample mass over the lot must be 3769 kg at 100 mm particle size, 59 kg at 25 mm and 0.81 kg at 6 mm nominal top size.

However, there is a requirement for a process control physical sample to monitor the particle top size from the mining operation. To extract this physical indicative sample, a secondary hammer sampler is designed onto the sampling plant primary feeder conveyor. This sample is not required to be ISO 8685 compliant but the removal of material from the chemical composite sample stream affects the final sample weight rendering the plant non-compliant. The physical sampler would extract a single physical sample increment, per alternating primary sample increment. The mass of each physical sample increment was calculated to be 8 kg and 21 kg at minimum and maximum production loading, respectively. Over the Lot period consisting of 44 primary sample increments, it would mean that 462 kg of the total primary sample increment would be removed from the system and not report to the ISO 8685 compliant chemical leg of the sampling plant. To account for this removal of material 3 additional primary sampler increments (now totaling 47 increments) would be extracted to substitute (257 kg per increment times 3) 771 kg of primary increment through the system at 10 kton/h throughput rates. The same proportionality also applies at the minimum throughput rates of 3.75 kton/h. To allow the 3 additional sample increments over the Lot period of 4 hours, the increment time had to improve from 5 minutes and 27 to the final design 5 minutes and 11 seconds. Previous increment minimum- and composite sample masses remains unchanged.

Now that the theoretical calculations for the sampling scheme requirements are determined, the automated mechanical equipment that can fulfill the requirements must be designed by the SEM.

## Practical design and equipment selection for the ISO compliant sampling plant

Figure 1 below provides the block flow diagram for the sampling plant design resulting from suitable equipment selection. The tabulated values for each stream list the particle size at that unit operation. The minimum and maximum sample masses (proportional to minimum and maximum production throughout rates) per single increment and over a 4-hourly lot period is tabulated. The subsequent text explains how the sampling plant meets the requirements of the sampling scheme design and continues to discuss relevant equipment design considerations.

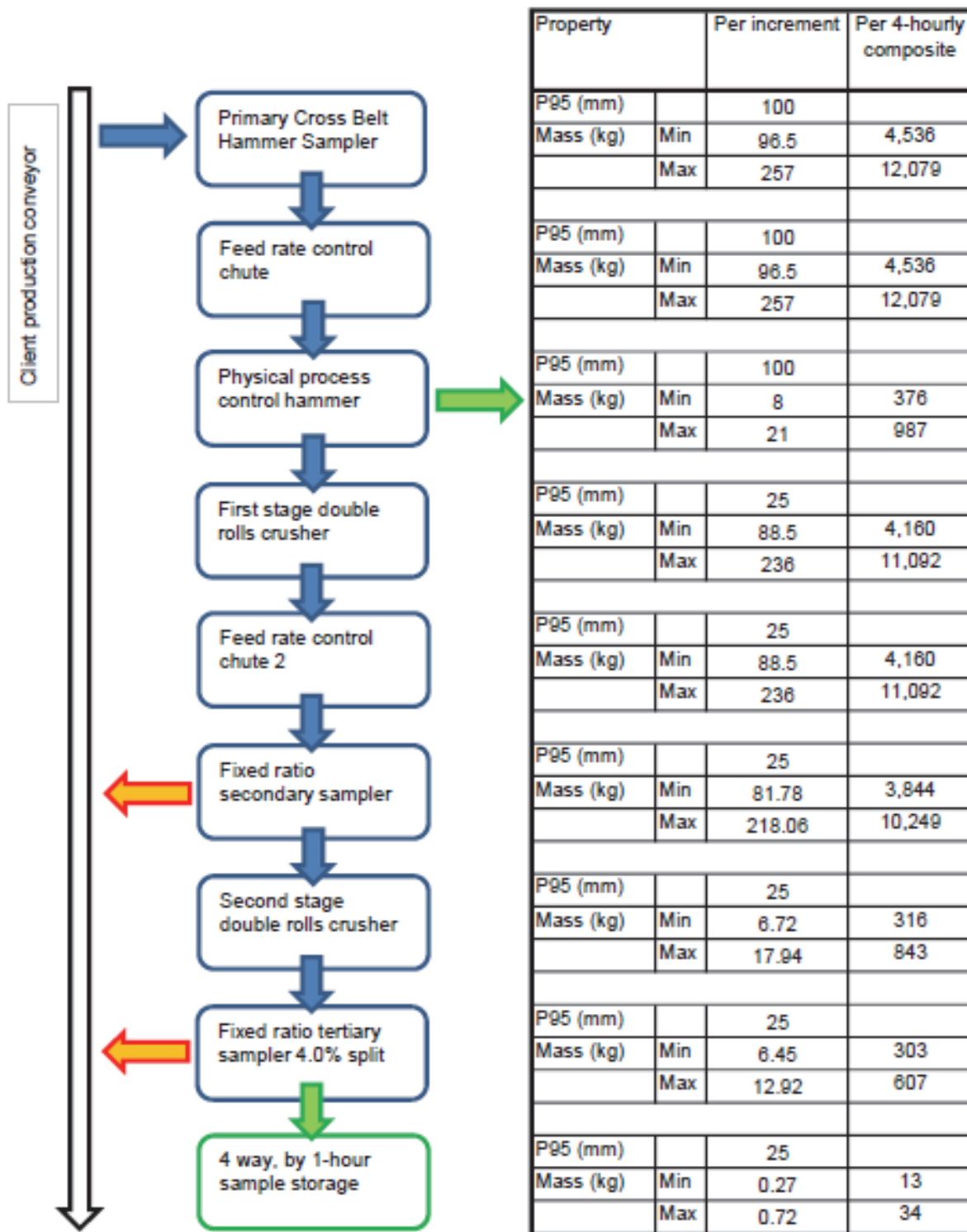

**Figure 1. Sampling plant block flow diagram tabulating corresponding sample weight per increment and composite sample weight per Lot size listed against each unit operation.**

Comparing Figure 1 listed sample mass to the sampling scheme design values from the previous section, it can be concluded that not only the primary increment masses of 257 and 88.5kg exceeds the minimum ISO 8685 requirement of 85.7 kg, but also the composite sample masses (after 47 increments) exceed the minimum requirements: 4536 against 3769 kg, 316 against 59 kg and 13 against 0.81 kg.

The resulting 34 kg of composite sample at highest throughput rate of 10 kton/h is split between four off 1-hourly sample bins and therefore still ergonomic and within laboratory constraints for 10kg per sample.

The sampling scheme design exceeds minimum ISO 8685 requirements while allowing ergonomic samples at the end of the Lot according to Lab constraints.

**Primary Sampler.**

The primary, cross belt hammer sampler was purposefully designed for the application with main components illustrated below (Figure 2).

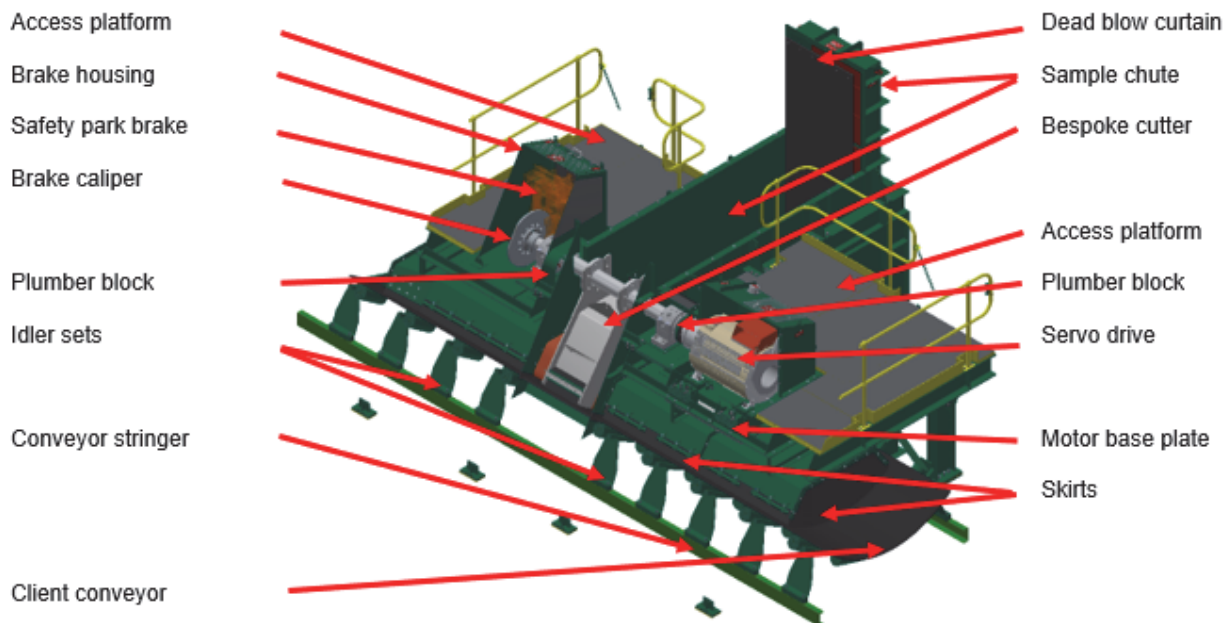

**Figure 2. Main components of the hammer sampler seen from the drive end – sectional view without support frame. Handrails appear incomplete resulting from the sections made on the model to show the operational parts.**

The primary sampler uses a 500 mm wide cutter and a unique servo drive system to provide the torque required to cut with constant speed across the 10 kton/h production stream, moving on a conveyor at 5.4 m/s. The sampler is purposefully designed for the application and has a number of design features implemented to minimize potential error generating mechanisms typically associated with commonly available cross belt samplers (Pitard, 2005<sup>11</sup>; Robinson, Sinnott, and Cleary, 2008<sup>12</sup>). A full technical paper on the details of this machine, designed and built under affiliated Licensor Siebtechnik GmbH, is published in the WCSB 10 proceedings (“Cross Belt Sampler Mechanical Design of the World’s Largest Hammer Sampler for Bauxite Export Contractual Requirements” but not added to the reference list because it is not yet published).

The increment mass collected by this sampler (and listed in Figure 1 above) is calculated using:

$$M_I = \frac{q_m \times b_c}{3.6 \times v_{pc}}$$

$M_I$  is the mass of the increment in kilogram.

$q_m$  is the production throughput on the conveyor in ton/h.

$b_c$  is the cutter aperture in meter.

$v_{pc}$  is the production conveyor velocity in m/s.

It must be noted that the sample increment mass calculation above is not the same as the calculation for cross stream samplers; see ISO 8685:1992, page 10 for the required formula and parameter definitions for cross stream sample increment mass calculation.

### Secondary and tertiary samplers

Secondary and Tertiary samplers are Rotating Plate Dividers (RPDs). These automated mechanical samplers use a large diameter rotating disc “fly wheel” design, that rotates at <0.45 m/s cutter tip speed, to drive a cutter through the feed inlet stream and isolate samples through the rotating plate into the sample chute while the sample rejects remains on the feed end of the rotating plate (Figure 3). RPDs run continuously, without stop starts or forwards/backwards movement, with significant inertia that results in ultra-simple and reliable operation with minimum maintenance and no finicky parts that requires attention. RPDs are started direct online, uses a helical bevel gearbox and motor that drives a shaft, to drive the rotating plate. The cutters are mounted to the rotating plate. The equipment design includes sampling error combating features: a round and steep feed pipe to minimize segregation, perpendicular cutter-to-feed pipe interception, radially tapered cutter(s) with rounded corners to prevent material hang-up and seal arrangements between the rotating plate and stationary sample-rejects-chute intercept to prevent material misplacement. In their continuous operation, RPDs readily achieve more than 20 sub cuts of the preceding sample increment. Their performance exceeds minimum ISO 8685 requirements of 6 sub cuts per preceding increment and will result in improved sampling precision level. The cutters are interchangeable and can accommodate different apertures for different sample sizes to adapt to sampling regime

requirements/amendments. The rotating plate can allow up to 4 of the interchangeable cutters making the design flexible, at low cost, to adopt to sampling regime requirements.

The secondary sampler subsamples the -25mm material using two off, 3 times top size cutters of 75mm aperture. The division ratio of secondary sample weight out of total feed weight is 7.6% (the remainder is sample rejects).

The smaller tertiary sampler uses 1 off 50 mm cutter to sub sample the nominal -6 mm secondary increment in a 4% fixed ratio to produce the tertiary sample. A three times top size cutter of 18mm is not employed to allow ease of operation and unblocking which is impractical for smaller cutter apertures.

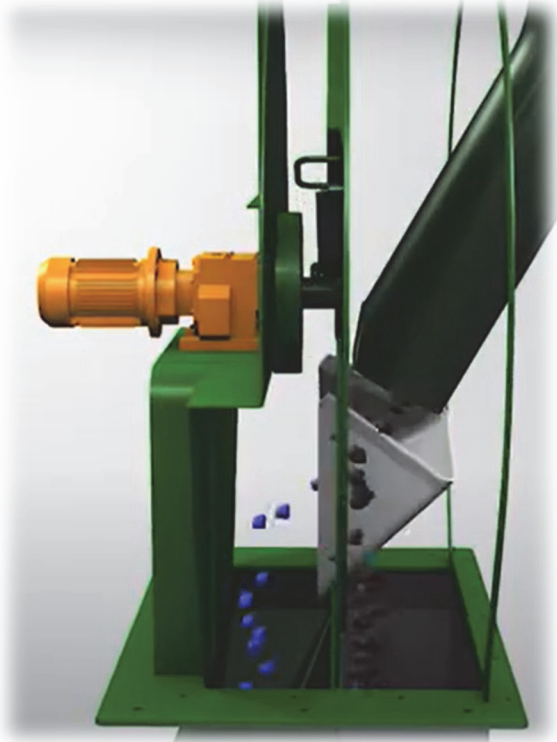

**Figure 3. Sectional view of the Rotating Plate Divider feed pipe (on the right) presenting a sample increment to the cutter (middle) to sub-sample (blue particles) the stream and generate rejects (black particles) on the feed side of the plate. Sample and rejects report to separate, isolated chutes.**

### Crushers

The project design criteria call for impact hammer mill type crushers typically used on Australian Bauxite. However, test work confirms that impact hammer mills are not efficient in their reduction ratio of reducing Guinean bauxite material. The test results reaffirm the use of double rolls crushers on existing Guinean bauxite sampling plants. This material deposit has nodules of Aluminium-rich material with Mohs hardness of up to 7, embedded in a much softer substrate with Mohs hardness of 3 (Figure 4). Primary sampling plant crushing from 100 to 25 mm is achieved relatively easily, but once the hard nodules are released from the substrate material, the crushing of these nodules are more taxing. The standard double rolls crushers must be upgraded with regards to spring tension, bearings, stub-shaft material and diameter, drive power and material of construction of the rolls themselves requiring already work-hardened manganese alloy. Guinean Bauxite becomes very sticky at critical moisture contents and could choke up the stationary impact surfaces of impact hammer mills. Double rolls crushers aid to drive the material through the rolls and are less prone to operational blockages.

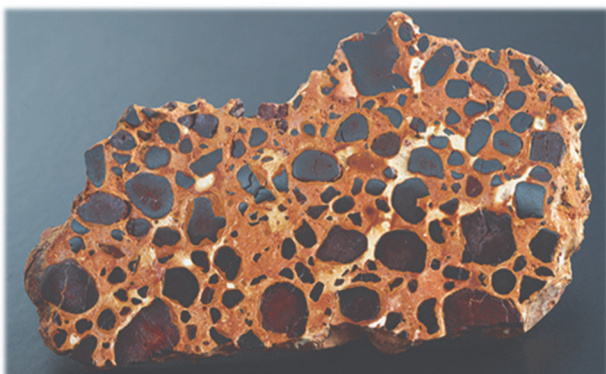



**Figure 4. Bauxite material showing soft substrate material in brown and hard nodules in reddish-black. Nodules are typically liberated at 50 mm and have a diameter of 5-30 mm.**

#### Equipment seal arrangements

The crusher inlet and outlet chutes are designed with overlapping rubber seal arrangements to prevent loss of fines (sample bias generator) while still allowing maintenance access.

All other chutes in the plant are designed as either bolt on chutes with seal gaskets or tailored overlapping rubber seal arrangements to prevent selective sample loss or sample contamination.

All sampling equipment are sealed to contain and prevent sample contamination.

#### Feed control chutes

Proprietary feed control chutes allow for mechanical adjustment of profile plates that forms the material burden width and height, manipulating the cross-sectional area through which increments are extruded thereby adjusting increment draw out rates. The chute design allows control towards subsequent sub sampling number of cuts. The chutes are designed with steep angles and proprietary geometry to prevent blockages. The generous chute volume acts as intermediate storage vessels from where samples are extruded by the underlying conveyor – minimizing segregation of material through the plant.

#### Feeder conveyors

Sample feeder conveyors are equipped with variable frequency drives to adjust their speed and throughput rate. This easily implemented-, adjusted in real-time flexibility ensures that samples are processed timeously through the plant, but also that crushers are not overfed when increased material hardness requires longer crusher “residence time”. Most importantly adjustable belt speeds allow the sample increment to be stretched out and achieve more than 20 sub cuts through downstream sampling. Conveyors are fully skirted to prevent sample loss, fully cladded to prevent sample contamination and include scrapers at the head end pulley to allow fines to report through the plant and be proportionally accounted in the composite sample.

#### Sample storage carousel

A 6-way sample storage carousel is designed to allow safe storage of the four 1-hourly composite samples, plus two spare slots for operational contingency. The carousel is equipped with a protruding feed pipe to ensure all fine material reports into the composite sample bin and does not flare over the drum rim and is lost. When the bin is indexed out of the receiving position, the top of the bin is sealed with a flexible gasket to prevent sample contamination while the bin is in storage. The carousel can be indexed manually from the control panel to allow the operator to remove all bins consecutively from the same door. Interlocks are provided to prevent the carousel from indexing while the door is open and operators can be exposed to moving equipment.

#### Rejects

The sampling plant includes automated rejects handling through rejects chutes after secondary and tertiary sub sampling onto a rejects conveyor that report back onto the production conveyor.

#### Material handling.

Bauxite is notoriously sticky at elevated moisture content but still below the transportable moisture limit. Over and above the sampling plant design, equipment selections should bear cognizance of potential blockage problems. All chutes with practical geometry are lined with low coefficient of friction, polymer liners. Special polyurethane tools (shovels, picks, spatulas) are required to clean the sampling plant where normal steel tools would scratch the liners and increase the surface roughness. Chute angles are designed to have minimum 70-degree angles and 65-degree valley angles which contributes to sampling tower height and capital cost. Most chutes are equipped with blocked chute detectors which upon detection would activate a PLC controlled vibration motor sequence to release the blockages. The system works well and clears blockages automatically, even under challenging conditions, without stops or operator intervention. Vibration transfer into the structure is prevented by suspending the chutes with chain from the ceiling since chutes cannot be bolted to equipment or the structure. Ultimately the additional blockage clearing system costs are worth the expense by preventing operational

challenges, promoting plant availability and because sampling plant healthy operation is interlocked with the production conveyor running - production stoppages are a minimum.

### Performance – bias testing

The sampling plant, sample preparation and analytical procedures were bias tested 6 months after commissioning, by an independent, experienced third party. The bias test results can be seen in Figure 5 below. The reference samples were extracted from the stopped production conveyor as per standard industry practice and in compliance to ISO – 10226 Aluminium ores – experimental methods for checking the bias of sampling<sup>13</sup>. The composite chemical sample results were compared to the profile plate reference belts cuts over 60 sample sets (one set comprising the composite system sample and reference samples A and B). No separate bias testing of the primary sampler was conducted – only the entire sampling plant performance was tested.

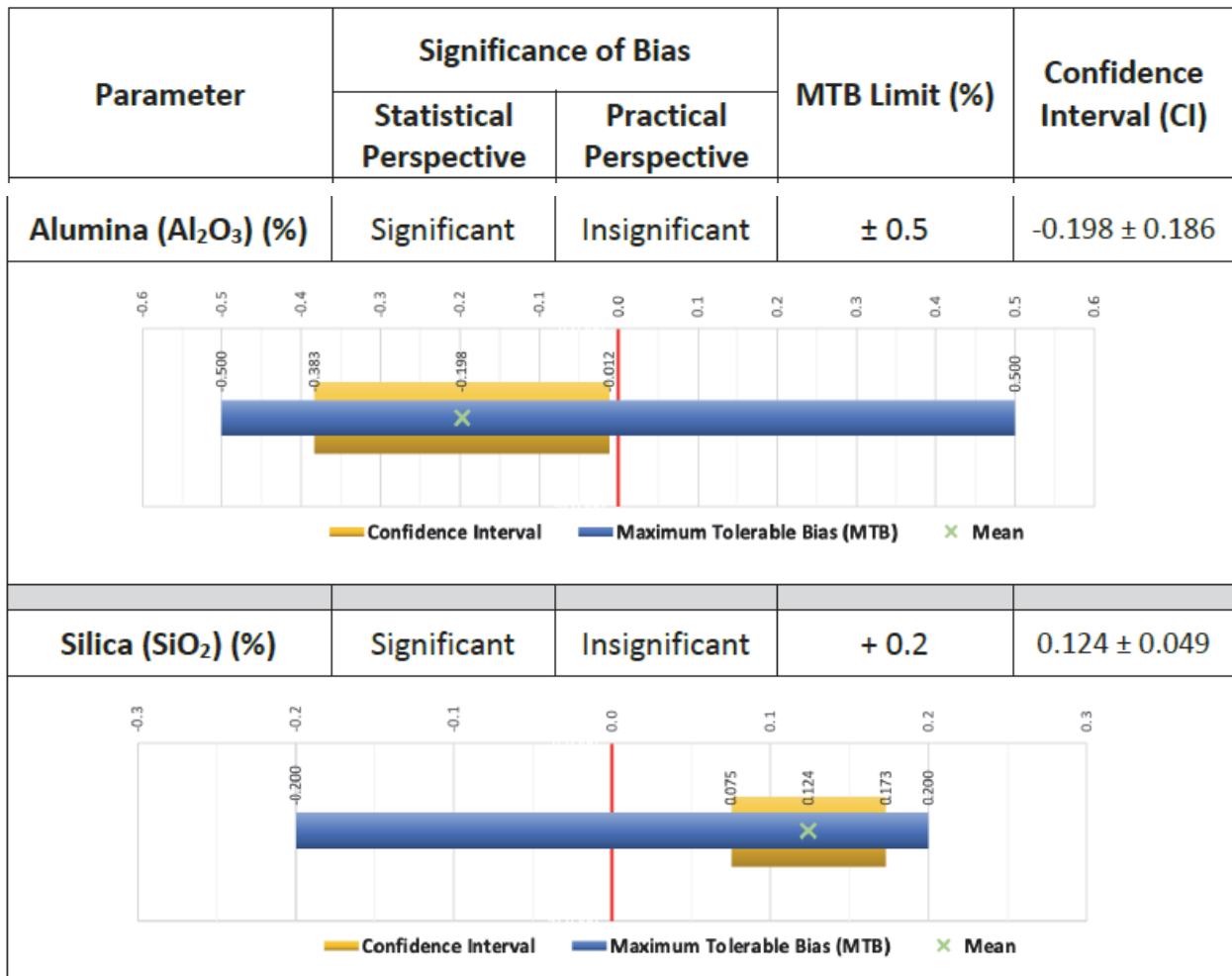

**Figure 5. Bias testing results of the sampling scheme showing client specified Maximum Tolerable Bias Level (MTB) with the blue line, bias test results with the yellow line.**

Bias detection was done in accordance to ISO – 10226<sup>13</sup>. A bias from a statistical perspective was observed where the average and standard deviation (position and span of the yellow line) does not intercept zero. However, from a practical point of view the data renders the bias irrelevant since the confidence interval falls within the MTB limits set out by the client as applicable to their commercial trade parameters.

Silica grade is overreported against the reference samples. The client informed that the Silica grade reports in the fine fraction. This implies that fines are oversampled in their proportion in relation to the Aluminium bearing coarser material. This finding is in direct contradiction to claims that hammer samplers tend to leave fines on the belt. An isolated bias test on the primary hammer sampler only (not the entire sampling plant) would be a more conclusive basis to support this claim.

Aluminium grade was slightly underreported while Silica content slightly overreported against the “truth” (reference samples). If the seller of bauxite is faced with a contractual claim for quality (low Aluminium content or high Silica content), the under and over reporting of respective elements would act in the bauxite seller’s favor to defend the claim when explaining that the sampling plant values are conservative on each quality parameter.

## Conclusions

To allow ISO 8685:1992 compliance requirement calculations, this design leveraged off variance data available from a neighboring operation. Without the neighboring plant's reference data variance data required as input to ISO calculations would otherwise not be available. Daring assumptions towards such variance may leave the sampling scheme designer unfeasible against uninformed competitors that would propose non-compliant systems.

Crusher test work was paramount to determine some of the ISO compliance calculation parameters for particle size which otherwise would not allow the calculation of sample masses through the various sampling and subsampling stages of the sampling scheme design. Double rolls crushers are recommended for crushing of Guinean bauxite ore in sampling plant infrastructure.

Without the above two data sets, the client faces a risk of building a sampling plant, where if assumptions are not true, will result in significant capital investment to upgrade the plant and if not implemented will result in a non-compliant or non-operational sampling plant. Sampling results are needed before sampling variance can be calculated and only then can a compliant sampling scheme be designed. The interdependence of a sampling plant to generate reliable variance data – before it is built – so that a reliable sampling plant can be built is a catch 22 and makes ISO standard compliance difficult to implement practically where information is not available in the design phase.

For this system providing chemical ISO compliant samples and indicative physical oversize samples, primary increments are collected every 5 minutes and 11 seconds to total 47 increments over a 1-hour subplot, 4-hour lot period. Each increment must have minimum mass of 85.7kg, which was well exceeded with 96.5kg at 3750 ton/h and 257 kg at 10 000 ton/h production rates, respectively. The total composite sample mass over the lot must be 3769 kg at 100 mm particle size, 67 kg at 25 mm and 1 kg at 6 mm nominal top size. These values are also comfortably exceeded.

A bias from a statistical perspective is observed, but from a practical point of view, the standard deviation is low and falls within the minimum tolerable bias limits set by the client. The sampling scheme is ISO compliant, performs reliably with good availability and performs well for chemical grade sampling.

## References

1. International Organization for Standardization. (1992). Aluminium Ores – Sampling Procedures – (ISO 8685:1992(E)).
2. Holmes, R.J. 2010. Sampling Mineral Commodities – the good, the bad and the ugly. *The Journal of The Southern African Institute of Mining and Metallurgy*, vol. 110, June 2010. pp 269-276.
3. Minnitt, R.C.A. 2007. "Sampling: The impact on costs and decision making". *The Journal of The Southern African Institute of Mining and Metallurgy*, vol. 107, July 2007. pp 451-461.
4. Steinhaus, R.C., and Minnitt, R.C.A. 2014. "Mechanical Sampling - a Manufacturer's Perspective". *The Journal of The Southern African Institute of Mining and Metallurgy*, vol. 114, January 2014. pp 121-130.
5. Lyman, G. J. 2019. *Theory and Practice of Particulate Sampling an Engineering Approach*. 1st ed. Materials Sampling and Consulting.
6. International Organization for Standardization. (1992). Aluminium Ores – Sampling Procedures – Part 4.3: General procedure for sampling (ISO 8685:1992(E)).
7. Danish Standards Foundation. (2013). Representative Sampling Horizontal Standard – (DS 3077:3013).
8. International Organization for Standardization. (1992). Aluminium Ores – Sampling Procedures – Part 5.2.1: Increment variance method (ISO 8685:1992(E)).
9. International Organization for Standardization. (1992). Aluminium Ores – Sampling Procedures – Part 6.1: Minimum mass of gross sample (ISO 8685:1992(E)).
10. International Organization for Standardization. (1992). Aluminium Ores – Sampling Procedures – Table 2 (ISO 8685:1992(E)).
11. Pitard, F. 2005. "Sampling Correctness – A Comprehensive Guideline". *Sampling and Blending Conference*, Sunshine Coast, QLD, 9 - 12 May 2005.
12. Robinson, G.K., Sinnott, M.D., and Cleary, P.W. 2008. "Can Cross-Belt Cutters be Trusted?" *Sampling Conference*, Perth, WA, 27 - 29 May 2008.
13. International Organization for Standardization. (1991). Aluminium Ores – Experimental methods for checking bias of sampling – (ISO 10226:1991).

## Applications of the Sampling Uncertainty (SU)

---

Bo Svensmark

Department of Plant and Environmental Sciences, University of Copenhagen, Faculty of Science, Thorvaldsensvej 40, DK-1871, Frederiksberg C, Denmark, E-mail: [svensmark@plen.ku.dk](mailto:svensmark@plen.ku.dk)

---

The Sampling Uncertainty (SU) recently proposed allows the estimation of the sampling uncertainty including the Grouping and Segregation Error (GSE), the Fundamental Sampling Error (FSE) or the Fundamental Sampling Uncertainty (FSU) and the long range sampling errors for 1-dimensional sampling. SU is calculated from the spatial distribution of the analyte in a manner similar to cyclic convolution. For 1-dimensional sampling SU is shown to be better than variogram integration in case of cyclic or non-stationary variations and by being independent of the nugget effect when the nugget effect is close to zero. Three cases will be treated in detail: The problems with a low nugget effect, the effect of autocorrelation on 1-dimensional sampling and the effect of cyclic variations. For the effect of cyclic variations discrete Fourier transform (DFT) analysis is included to explain the findings and to filter the data. Finally, it is shown that DFT and SU give similar results for the cyclic pattern in the data when SU is calculated for a sampling ratio  $\text{mass}(\text{lot})/\text{mass}(\text{sample}) = 2$ . Even though SU itself can estimate the sampling uncertainty correctly, it is proposed always to include a variographic analysis and a DFT analysis to characterize the spatial heterogeneity of the data.

### ORCID iDs

Bo Svensmark: <https://orcid.org/0000-0003-0430-6181>

### References

1. Bo Svensmark, *Extensions to the Theory of Sampling 2. The Sampling Uncertainty (SU), and SU as alternative to variographic analysis*, Proceedings of the 10<sup>th</sup> World Conference of Sampling and Blending...
2. B. Svensmark, *Extensions to the Theory of Sampling 1. The extended Gy's formula, the segregation paradox and the fundamental sampling uncertainty (FSU)*, *Analytica Chimica Acta* **1187**, 339127 (2021). <https://doi.org/10.1016/j.aca.2021.339127>
3. R. Heikka ) and P. Minkinen, *Integration of the variogram using spline functions for sampling error estimation*, *Chemo-metrics and Intelligent Laboratory Systems* **44**, 205–211 (1998). [https://doi.org/10.1016/S0169-7439\(98\)00187-7](https://doi.org/10.1016/S0169-7439(98)00187-7)
4. B. Svensmark, *Toolbox for analytical chemistry*, [www.bosvensmark.dk](http://www.bosvensmark.dk)

## The extended Gy's formula

---

Bo Svensmark

Department of Plant and Environmental Sciences, University of Copenhagen, Thorvaldsensvej 40, 1871 Frederiksberg C, Denmark E-mail: [svensmark@plen.ku.dk](mailto:svensmark@plen.ku.dk)

---

Gy's formula is a formula to predict the Fundamental Sampling Error (FSE), a part of The Theory of Sampling (TOS) as developed by Pierre Gy. Gy's formula is only valid for binary materials with the same size distribution of analyte containing fragments and matrix fragments. Unfortunately, the formula has been used without regard to these limitations, and the results have often been erroneous, giving the Theory of Sampling a bad reputation. However, an extended Gy's formula for estimation of FSE without these restrictions can be derived from Gy's definition of constitutional heterogeneity. This formula is exact with no assumptions, except that the lot can be divided into classes with fragments with similar properties within each class. The extended formula allows prediction of FSE for any particulate material with any number of particle classes in contrast to Gy's formula. The extended Gy's formula is validated by model experiments sampling mixtures of 3 to 7 components with a riffle splitter. In most cases the observed sampling error was well predicted by the newly derived, extended Gy's formula. However, in some experiments the observed sampling errors were lower than FSE. This can be explained by the segregation paradox, and the effect is calculated by a new function, the Fundamental Sampling Uncertainty (FSU) proposed here. The observed results are now typically in excellent agreement with the predictions (the predicted uncertainties were on average 0.5% points lower than the observed values). The extended Gy's formula is easy to use. For a material where the analyte is only present in one class of fragments, the only parameters needed for each class are the average mass of a fragment and the mass proportion of the class in the lot. No need to estimate the liberation factor, the size and shape of the fragments and the concentration. If the analyte is present in more than one class, the concentration in each class is needed too. If fragments of a class have similar properties, but not similar size, the granulometric factor is needed though, and an exact formula for a uniform size distribution has been derived. This formula predicts that the granulometric factor  $g$  for a wide size distribution is 0.25 in excellent agreement with Gy's recommendation for this case. The extended Gy's formula described here is ideal for use in teaching of sampling methods because the experiments can be set up using materials with accurately known properties. The proposed new formula allows accurate prediction of FSE and FSU for complex materials that contain more than two types of particles. It is the hope that the extended Gy's formula could increase the popularity of TOS.

Bo Svensmark: <https://orcid.org/0000-0003-0430-6181>

Bo Svensmark, *Extensions to the Theory of Sampling 1. The extended Gy's formula, the segregation paradox and the fundamental sampling uncertainty (FSU)*, Anal. Chim. Acta 1187 (2021) 339127. <https://doi.org/10.1016/j.aca.2021.339127>

Bo Svensmark, *Extensions to the Theory of Sampling 2. The Sampling Uncertainty (SU), and SU as alternative to variographic analysis*, Proceedings of the 10<sup>th</sup> World Conference of Sampling and Blending...

Bo Svensmark, *Toolbox for analytical chemistry*, [www.bosvensmark.dk](http://www.bosvensmark.dk)

## Representative Sampling for Food and Feed Materials: A Critical Need for Food/Feed Safety – Special Edition Section of Journal AOAC International

K.H. Esbensen<sup>a</sup>, C.Paoletti<sup>b</sup>, N. Thiex<sup>c</sup>

<sup>a</sup>Owner, Consultant KHE Consulting, Copenhagen, DK [khe.consult@gmail.com](mailto:khe.consult@gmail.com)

<sup>b</sup>European Food Safety Authority, Parma, IT, [Claudia.PAOLETTI@efsa.europa.eu](mailto:Claudia.PAOLETTI@efsa.europa.eu)

<sup>c</sup>Thiex Laboratory Solutions, LLC, Brookings South Dakota, USA [Nancy.Thiex@gmail.com](mailto:Nancy.Thiex@gmail.com)

Technically, sampling of food and feed is the process of selecting a small mass from a larger quantity of material for the purpose of performing a measurement, quantitative or qualitative, on the selected portion and making valid inferences with respect to the entire target mass (Decision Unit). It is too often simply assumed (without justification) that the representativeness and integrity of the sampled material is a given, and consequently also erroneously assumed that the measurement results obtained can be used to make reliable inferences about the target. This is a seriously mistaken assumption.

Sampling of food and feed materials is performed for a number of reasons at various stages of an integrated food safety system, including but not limited to, premarketing risk assessment, process control in a food/feed manufacturing environment, first responder investigations to foodborne disease outbreaks, and regulatory compliance (agencies/programs performing monitoring or surveillance of food or feed products in support of food safety surveillance of food or feed products in support of food safety regulations).

While sampling situations are diverse, and for many the immediate thought is that specific sampling procedures probably should be tied in with the specific nature of the products or processes being sampled, a singular, unified approach can in fact address all situations and products, aiming for a fit-for-purpose (fit-for-decision) representative sampling process.

The target audience includes food/feed protection personnel, e.g., field sampling operators, academic and industrial scientists, laboratory personnel, companies, organizations, regulatory bodies, and agencies that are responsible for sampling, as well as their project leaders, project managers, quality managers, supervisors, and directors who are responsible for business and other decisions of economic and societal importance. In the United States alone there are an estimated 45,000 federal, state, and local food/feed regulatory personnel, not including industry or laboratory personnel. With a conservative estimate of 50-75% of them involved in sampling activities, the target audience forms a very sizable body in the United States as well as worldwide. For the world at large, the relevant numbers are exorbitant. There is much to do ...

And there is here a powerful carry-over effect beyond food and feed sampling. The general principles presented apply to any-and-all materials (lots, DUs) with similar heterogeneity characteristics as those in the food, feed, and environmental sciences. Perhaps paradoxical at first view, sampling of heterogeneous materials is in a sense a matrix-independent endeavour, only the material heterogeneity counts<sup>2-5</sup>. In this sense ref. 1: "Representative Sampling for Food and Feed Materials", Special Guest Editor Section Journal of AOAC International, vol. 98, No. 2 (2015) constitutes a general introductory mini-text book for representative sampling<sup>1</sup>.

1. DOI: 10.5740/joacint.SGE\_Esbensen\_intro [OPEN ACCESS]
2. K.H. Esbensen, "Materials properties: heterogeneity and appropriate sampling modes", J. AOAC Int. 98(2), 269–274 (2015). <https://doi.org/10.5740/joacint.14-234>
3. K.H. Esbensen, Introduction to the Theory and Practice of Sampling. IM Publications Open (2020). <https://doi.org/10.1255/978-1-906715-29-8>
4. F.F. Pitard, Theory of Sampling and Sampling Practice, 3rd Edn. CRC Press (2019). <https://doi.org/10.1201/9781351105934>
5. DS3077, Representative Sampling—Horizontal Standard. Danish Standards (2013). <http://www.ds.dk>

## DS3077—Horizontal Standard revision after 10 years and induction as an ISO Standard

---

K.H. Esbensen<sup>a</sup> and L. Skerning<sup>b</sup>

<sup>a</sup>Chairman taskforce DS3077 Revision Chairman taskforce DS3077 Revision. E-mail: [khe.consult@gmail.com](mailto:khe.consult@gmail.com)

<sup>b</sup>Taskforce secretary DS3077 Revision (2023) E-mail: [ls@ds.dk](mailto:ls@ds.dk)

---

**DS3077 “Representative Sampling – Horizontal Standard”, released in 2013, is a Danish Standard but was from the start intended as a *de facto* international standard. DS3077 (2013) was the result of growing international frustration over the lack of a comprehensive standard covering general sampling issues and recommendations regarding practical sampling across the countless specific matrices targeted within science, technology, industry, trade, commerce, regulatory and law-enforcing agencies and in society at large. Within these application sectors, before 2013 there was a belief that specific material-dependent sampling procedures (and equipment) were needed. It was assumed that these issues were better addressed in specific matrix-related standards dealing with handling of important commodities and general classes of materials, with dedicated chapters on their sampling included. Thus, for a long time, sampling issues were relegated to such minor chapters, or subchapters only, never receiving the full attention deserved. Progress on developing general sampling principles was therefore absent from the international standards arena. This was status quo at the time the first World Conference on Sampling and Blending, WCSB1, took place in 2003. But in the immediately following years it was realized just how big the need for a general approach was. Something had to give.**

Therefore, it fell to a small R&D group at a peripheral university location in the outskirts of Europe to break this deadlock: But who had ever heard of the city of *Esbjerg* (5.th largest city of Denmark, itself a nation hardly among the leading players in the EU). Never-the-less, at the satellite university campus of Aalborg University (currently, its engineering department rated 8<sup>th</sup> in the world, and number 1 in Europe), a new professorship was inaugurated dedicated to *chemometrics* and *sampling*, both new disciplines on the engineering curriculum. Not necessarily a promising academic environment from which to take on the world – and with aspirations to develop the world’s first ‘horizontal’ sampling standard (horizontal: = matrix-independent). 2008 saw the first committee meetings devoted to scope out this task, which at the time seemed quite formidable, if not almost hopeless. As it turned out, the gestation period was precisely five years. The full historical record of this endeavor can be found here: “*DS 3077 Horizontal—a new standard for representative sampling. Design, history, and acknowledgements*” doi: 10.1255/tosf.7

Fast forward: Ten years later, 2022, it is time to revise DS3077. Normally standards are revised with intervals of ca. five years, but in the present case, a national standard with clear international ambitions, rules and regulations were deliberately loosened up, to give the standard a fair try of proving its value. At the time closing in on its 10-year anniversary, Danish Standards conducted a critical survey of its “history” (the sales history) – and found the evidence of its merit and usefulness quite satisfactory, numerically and otherwise.

Thus, revision of DS3077(2013) is now on the agenda for 2022/2023. This POSTER is a call to interested parties and stakeholders to consider contributing to this revision. Revision of the Danish standard (from 2.nd. to 3.rd edition) will take part in Q3 and Q4, 2022. Immediately following the release of DS3077(2023), 3.rd edition, work will begin on introducing the fully revised edition into the ISO realm, following standard ISO procedures. This POSTER is also a call to all interested parties to consider contributing to this ISO process. It is felt that WCSB10 is a perfect occasion to reach out to catch the attention of potential taskforce members from all over the International Pierre Gy Sampling Association (IPGSA) community!





# Introduction to the Theory and Practice of Sampling

Kim H. Esbensen

with contributions from Claas Wagner, Pentti Minkkinen, Claudia Paoletti, Karin Engström, Martin Lischka and Jørgen Riis Pedersen

“Sampling is not gambling”. Analytical results forming the basis for decision making in science, technology, industry and society must be relevant, valid and reliable. However, analytical results cannot be detached from the specific conditions under which they originated. Sampling comes to the fore as a critical success factor before analysis, which should only be made on documented representative samples. There is a complex and challenging pathway from heterogeneous materials in “lots” such as satchels, bags, drums, vessels, truck loads, railroad cars, shiploads, stockpiles (in the kg–ton range) to the miniscule laboratory aliquot (in the g– $\mu\text{g}$  range), which is what is actually analysed.

This book presents the Theory and Practice of Sampling (TOS) starting from level zero in a novel didactic framework without excessive mathematics and statistics. The book covers sampling from stationary lots, from moving, dynamic lots (process sampling) and has a vital focus on sampling in the analytical laboratory.

“I recommend this book to all newcomers to TOS”

“This book may well end up being the standard introduction sourcebook for representative sampling.”

“One of the book’s major advantages is the lavish use of carefully designed didactic diagrams”

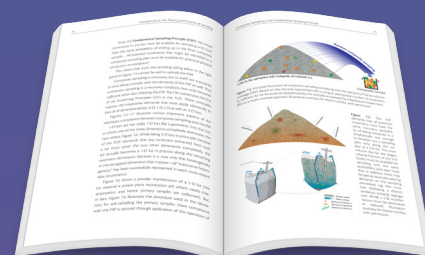
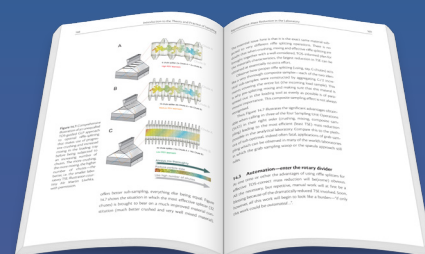

[impopen.com/sampling](http://impopen.com/sampling)

IMPOpen