

ISSUE 1 · JANUARY 2024

FORUM FOR THEORY AND PRACTICE OF REPRESENTATIVE SAMPLING



# SST

SAMPLING SCIENCE & TECHNOLOGY

## Application of PhotonAssay™ to Coarse-Gold Mineralisation

The Importance of Rig to Assay Optimisation



Tribute to Ian Michael  
(1958-2023)



Obituary: Geoffrey Lyman  
(1948-2023)

**IPGSA:  
A New Beginning**

Vision, Structure & Objectives

**Hidden Costs of  
Improper Sampling**

Educational highlights

**New Specialised  
Sampling Hub**

For Circular Economy

sst-magazine.info  
sampling-science-technology.info





Editorial..... 1

Application of PhotonAssay™ to Coarse-Gold Mineralisation – The Importance of Rig to Assay Optimisation ..... 2

By Simon C. Dominy, Janice C. Graham, Kim H. Esbensen and Saranchimeg Purevgerel

DS3077: Revised 3<sup>rd</sup> edition (2024)..... 31

Hidden Cost of Poor Sampling and Reconciliation Practices – Educational Lessons Far Beyond the Mining Industry..... 32

By Dominique Francois-Bongarcon and Kim H. Esbensen

International Pierre Gy Sampling Association: A New Beginning ..... 38

By Claudia Paoletti

If Mahomet Won't Come to the Mountain, the Mountain Must Come to Mahomet: Transforming Sampling and Preparation Services for Circular Economy Materials through a Specialised TOS-Compliant Mechanical Sampling Hub..... 42

By Duncan Aldwin Vogel

Tribute to Ian Michael (1958-2023) Publisher extraordinaire ..... 52

Giants of Sampling 1: Henry Augustus Vezin ..... 56

By Alan Rawle

Obituary: Geoff Lyman (1948-2023) ..... 60

**Cover Photo**

M2 Conglomerate Reef,  
Novo Resources Corp., Beatons Creek  
open pit, Nullagine, Western Australia  
Photo: Dr Simon Dominy  
Used with permission.

**Issue Sponsor**



We are most grateful to OCX Gold Group for sponsorship of this issue.

**Editor-in-chief:** Kim H. Esbensen  
E-mail: khe.consult@gmail.com

**Editorial Asst.:** ReConsider (Anne J. Cole, PhD)  
E-mail: anne@reconsideredit.com

**Publisher:** Benedikt Dolzer ·   
E-mail: sst@bd-verlag.de

# It's Time for Something Different. Sampling Science and Technology (SST): A New Home for TOS forum

By Kim H. Esbensen (Editor)

DOI: 10.62178/sst.001.001

You have just opened the inaugural issue of *Sampling Science and Technology* (SST), the new scientific magazine published by the International Pierre Gy Sampling Association (IPGSA). Welcome!

## Why this new magazine?

The reason is very sad. In late April 2023, IPGSA's Publisher since 2013, Ian Michael of IM Publications OPEN, unexpectedly passed away, succumbing to leukemia. This tragedy threw the fate of *TOS forum* and the regular SAMPLING column in *Spectroscopy Europe* into unknown territory as it quickly became clear that IPGSA could not expect a direct continuation of these outlets from our decade long publishing house. A tribute to Ian Michael and his invaluable support for the development of IPGSA can be found in this issue.

However, after ~20 years of organised work for the world sampling community, the time has also come for a revision of the scope and responsibilities of IPGSA, as set out in the article in this issue by Claudia Paoletti, IPGSA vice-president.

As part of this re-alignment, the Editor of both *TOS forum* and the SAMPLING column decided to amalgamate these publication outlets into the new publication: *Sampling Science and Technology* (SST), which defines itself squarely in-between a magazine and a journal. And we have found a new, equally compe-

**Scientific magazine:** a periodical publication containing articles and illustrations, often on a particular subject or aimed at a particular scientific or technological readership.

**Scientific journal:** a publication with an express goal of expanding, stimulating, and facilitating inquiry in a particular scientific field through publishing research, findings, or studies conducted by academic students, experts, or teachers.

tent and inspiring collaborating publishing house: Bendikt Dolzer, who is responsible for the pleasing new layout you'll find in this issue.

A conscious effort has been made to illustrate this intended position with the complement of solicited and submitted articles in this inaugural issue: a review of a new analytical approach of the highest interest for the global sampling community, an educational review of subtle, but powerful practical sampling approaches, presentation of a totally about-face concerning sampling *where?*, a position paper for IPGSA on the verge of a new era, a tribute to our lost *Publisher extraordinaire*, and a news flash re. a timely 3<sup>rd</sup> revision of the sampling standard DS3077. What's not to like?

## Welcome!

It is the intention to offer SST as a platform for scientific and technological interaction among all members of the world sampling community without in any way detracting

from also publishing in peer-reviewed scientific journals proper. However, the major impact from SST is intended to be educational at all levels of interest. That is, SST welcomes any-and-all didactic etudes, practical perspectives, exemplary case histories, as well as the occasional theoretical article aimed at the sampling community both *sensu stricto* and *sensu lato*.

## Participate.

This editorial is a call to action, to contribute to IPGSA's drive for building professional sampling competence across all societal sectors where sampling is on the agenda – in science, technology, industry, trading, food/feed, public health ... SST and its editor are fully at your disposition in this endeavor. One of the prime tasks in the first year of operation will be the establishment of a full editorial board – Interested parties are very welcome to suggest themselves.

But first and foremost: turn on your PC and start writing your contribution!

# Application of PhotonAssay™ to Coarse-Gold Mineralisation – The Importance of Rig to Assay Optimisation

By Simon C. Dominy<sup>1,2</sup>, Janice C. Graham<sup>3</sup>, Kim H. Esbensen<sup>4</sup> and Saranchimeg Purevgerel<sup>5</sup>

DOI: 10.62178/sst.001.002

## 1. Introduction

### 1.1 The Importance of Sampling

Sampling errors are additive throughout the complete lot-to-aliquot sampling value chain and can generate both monetary and intangible losses (Carrasco, Carrasco & Jara, 2004; Minnitt, 2007; Dominy, 2016; Lyman & Bourgeois, 2017; Lyman, 2019; Pitard, 2019; Esbensen et al., 2021). Sampling, inclusive of collection, preparation and assaying is a vital component of all stages of a mining project (Minnitt, 2007; Dominy, 2016; Lyman & Bourgeois, 2017; Pitard, 2019; Esbensen et al., 2021). This includes the sampling of *in-situ* material and broken rock for geological, metallurgical, geometal-lurgical and geoenvironmental purposes.

Field sampling is followed by sample reduction in both mass and fragment size to provide sub-samples for testwork or assaying. This process can be particularly challenging in the precious metal environment (e.g. gold and platinum). Sampling errors are defined in the Theory of Sampling (TOS) (Gy, 1982; Pitard, 2019; Esbensen, 2020). These errors are relevant to all applications across metallurgy, resource evaluation and grade control. To undertake representative sampling, practitioners need to

### ABSTRACT

Sample collection, preparation and assaying are a vital activity at all stages of a mining project. Field sample collection is followed by sample reduction in both mass and fragment size to provide a sub-sample for assay. This process can be particularly challenging in the precious metal environment and may require specifically designed protocols. One of the biggest challenges is ensuring that all sampling and sub-sampling errors are controlled across the entire rig to assay pathway. In most cases, the primary sampling error (the error at the rig and/or core shed) may swamp the entire process. Challenges also exist throughout all sampling stages when coarse gold is present. In particular, the pulp is likely to contain some liberated, poorly comminuted gold particles, requiring the pulp to be assayed *in total* to avoid unnecessary additional errors during splitting and handling. PhotonAssay™ is a non-destructive and rapid gold assay technique capable of analysing coarse crushed (<3 mm) 350–500 g samples at a rate of ~70 samples per hour. It displays fast assay turnaround-time, requires lower staffing levels to operate, and removes the need for chemicals such as lead or cyanide. These characteristics make it applicable to gold ores, particularly those bearing coarse gold, as only crushing is required (minimal liberated gold) and multiple lots can be assayed. However, this advantage will be reduced if any of the sampling stages are not optimised. The optimisation of a sampling protocol comes from understanding the mineralisation and desired programme outputs. It is not simply a mathematical, or a statistical process, but a complex process taking advantage of orebody knowledge (including gold deportment studies) and application of the Theory of Sampling.

optimise field sampling to assay protocols by undertaking characterisation of the mineralised domains present (Minnitt, 2007; Dominy, 2016; Villanova, Heberle & Chierigati, 2017; Dominy et al., 2021; Dominy, Glass & Purevgerel, 2022).

<sup>1</sup> Novo Resources Corporation, 46 Ventnor Avenue, West Perth, WA 6005, Australia.

<sup>2</sup> Camborne School of Mines, University of Exeter, Penryn, Cornwall TR10 9FE, United Kingdom.

<sup>3</sup> Snowden Optiro, 140 St Georges Terrace, Perth, WA 6000, Australia.

<sup>4</sup> KHE Consulting, Copenhagen, Denmark

<sup>5</sup> MSA Global LLC, Bayanzurkh District, Ulaanbaatar 13370, Mongolia.

TOS can be applied to optimise sampling of all types of stationary and dynamic lots as well as for comprehensive analysis of manufacturing and processing variabilities. TOS is the key factor to identify solutions with improved efficiency and the only effective tool for guarding against unnecessary economic and material losses.

## 1.2 Rationale for this contribution

Given the novel nature of PhotonAssay™, this contribution provides a summary of the technique and presents the key areas that the Competent/Qualified Person (CP/QP) must consider before implementing any changes to an existing protocol and/or introducing a new one. Key matters pertaining to the sampling of coarse gold mineralisation are also discussed. The paper is based on the experiences of a group of practitioners – some of whom are CP/QPs – who have extensive experience of the implementation and application of PhotonAssay™ across the mine value chain. The utility of PhotonAssay™ and the importance of “rig-to-assay” optimisation are exemplified through four case studies.

## 1.3 Peculiarities of Gold Sampling

### 1.3.1 Overview

There are several peculiarities of sampling for gold, which relate to both correct (CSE) and incorrect (ISE) sampling errors. For the definition of the TOS errors refer to Appendix Table A1 and for abbreviations used in this contribution Table A2.

The main influential drivers for the fundamental sampling errors (FSE) include:

- Primary gold particle distribution is often erratic (high geological nugget effect), with localised clustering effects (Dominy & Platten, 2007); and
- Grades are low (g/t Au), thus gold particles can be rare ‘events’ (e.g. Poisson distribution) particularly in low grade ores (Pitard & Lyman, 2013).

Those issues that contribute to the grouping and segregation error (GSE) and ISE include:

- Poor disintegration of gold particles during pulverising often lead to smearing and/or the coating of sample preparation equipment leading to PE (Royle, 1989; Dominy & Petersen, 2005; Dominy, 2017; Pitard, 2009); and
- Extreme contrast between the densities of gold and gangue minerals promote segregation once liberated which contributes significantly to GSE (Pitard, 2019; Minnitt, 2022; Minnitt, Dominy & Esbensen, 2022).

These problems can partly be reduced, but not eliminated, by using larger sample and assay charges in combination with careful procedures to minimise all sampling and sub-sampling errors.

Gold mineralisation often contains both fine (<100 µm) and coarse (>100 µm) gold particles. The in-situ size and shape, department, distribution and abundance of these particles controls deposit sampling characteristics, grade distribution and metallurgical properties. Gold particle sizing can range from individual disseminated, to clusters of particles, through to centimeter-scale masses. From a sampling perspective, mineralised domains can possess varied gold particle size characteristics.

Mineralisation containing substantive quantities of coarse gold (>15% above 100 µm) is often typified by a high geological nugget effect which represents variations in (1) the in-situ size distribution of gold particles (including the effects of gold particle clustering), and (2) gold particle abundance (Dominy & Platten, 2007; Dominy, Platten & Xie, 2008; Dominy, 2014). Where the sampling process is not optimised, the sampling nugget effect (SNE) is enhanced, increasing the total nugget effect (Francois-Bongarcon, 2004; Dominy, 2014).

### 1.3.2 Challenge of gold content and successive splits

The gold content of an extracted sample and the gold content of the surrounding mineralisation *can* be vastly different. Similarly, there may be significant differences between the primary sample, subsequent subsamples and the final fire assay (FA) charge unless rigorous procedural optimisation is undertaken. FA is the traditional method for gold assay (Hoffman, Clark & Yeager, 1999).

Skewed/non-normal distributions of assays arise from low primary sample masses and/or from insufficient pulverisation of material and assay charge mass. For mineralisation in each state of comminution, the true grade of a sub-sample will differ from that of the original ‘lot’. If sub-sampling is conducted in an unbiased correct manner, the actual assay difference will be due to the size and grade distribution of the gold particles in the lot and the nominal mass of the sub-samples.

Mineralisation dominated by fine gold may be broken to a particular size distribution with the gold particles spread throughout the host rock. There will be no gold particles that are fully liberated.

The distribution of gold within particles will be confined to low values that may reach a few hundred g/t. In this case the assay distribution within any of the size fractions is likely to be unimodal.

In the case where the gold particles are coarse, comminution will liberate some of the gold. In this case a given size fraction will contain both liberated gold and fine-disseminated gold in rock fragments. The liberated gold particles will bear very-high grades (into 1,000's g/t Au), which will form a distinct peak in the grade distribution. The grade distribution will be bi- or multi-modal, reflecting populations of fine disseminated gold and coarse liberated gold.

Gold particle clustering on the millimeter to centimeter scale may have a large effect on the block-to-hole, hole-to-sample, and sample-to-assay representativity (Dominy & Platten, 2007; Dominy, Platten & Xie, 2008, 2021; Dominy, Glass & Purevgerel, 2022).

There follows two examples on how the sample protocol applied can affect the final assay.

#### Example No. 1

Consider a 1 m length of NQ2 drill core of weight c. 6.4 kg. The true assay of the core is 10 g/t Au. The core contains c. 64 mg of gold. Assume 12.5 mg occurs as 10 coarse particles of 500  $\mu\text{m}$  diameter (coarse gold component of grade is 2 g/t Au), with the remaining 51.5 mg as small numerous <100  $\mu\text{m}$  particles that pose no sampling issues. If the entire core is crushed to  $P_{80} = 2$  mm and a 1.2 kg (1:5) split taken correctly, then the expected number of coarse gold particles is 2. However, the probability of collecting two particles is only 30%. If the first split yielded an assay of 11 g/t Au (20% probability;  $N = 3$ ), there are 7 coarse gold particles left in the remaining 5.2 kg residue. Based on 90% confidence limits, the likely number of particles collected will be between 0 and 2, and the split grade will lie between 8 g/t Au and 10 g/t Au.

If either 1.2 kg split is pulverised, where it is assumed that pulverisation is incomplete with substantial coarse gold left and not reduced in size, then the probability of collecting zero coarse gold particles is >95%, with a resultant gold grade of 8 g/t Au. There is a 4% probability of encountering a single gold particle, but in a 25 g FA charge this will yield a grade of 58 g/t Au. If pulverisation were more efficient, the probabilities of finding 0, 1, 2, etc. particles would be the same, but the assays would change where there is more disseminated gold and less coarse gold.

#### Example no. 2.

Pitard & Lyman (2013) provide a similar study, where a 3.84 kg length of NQ half core was pulverised in its entirety and assayed to extinction via 128 30-g FA. The mean FA grade was 2.31 g/t Au, with the range of FA being 0.36 g/t Au to 63 g/t Au showing a coefficient of variation (COV) of 328%. Some 88% (113) of the FA values understated the true mean of 2.31 g/t Au. Pitard and Lyman (2013) calculated that the mean coarse gold particle size in the lot was 743  $\mu\text{m}$ . Therefore, the average number of gold particles in a 30 g FA was 0.045, or 1 in 22 FA. The probability of a 30 g FA selecting no coarse gold was 96%; of selecting a single particle was 4%; and two particles 0.1%.

Both these examples highlight the marked challenge of using a 30 g FA charge in the presence of coarse gold and the likelihood of a highly skewed grade population resulting. These analyses reiterate the fact that where the pulverising process is inefficient, assays provide for the appearance of 'erratic' mineralisation. A well-pulverised pulp need not be a guarantee of correct sample preparation; the assay of the crushed rock submitted to the pulveriser may already bear no resemblance to that of the original sample. Similarly, well-behaved pulp duplicates need not imply an efficient process either if a key part of the gold particle population has a high probability of not being selected in the rig to pulp path. It is critical *where* in the compound rig-to-pulp pathway changes in pulverisation efficiency and monitoring is brought to bear, for example by duplication. The systematic use of replication as a QAQC vehicle is discussed in Abzalov (2008), Esbensen (2020) and Dominy, Purevgerel & Esbensen (2020).

While grade is often correlated to gold particle size and abundance in the sample, the relationship between sample grade and the surrounding ore is complex (Dominy & Platten, 2007; Dominy, Xie & Platten, 2008). High grades (>15 g/t Au) often relate to abundant coarse gold and/or clustered gold particles which, by virtue of their high-grade, may not be too challenging to sample. Interpretation of samples containing coarse gold-bearing low-grade (<5 g/t Au) mineralisation is challenging. The sampling and preparation of coarse gold mineralisation is discussed further in Royle (1989), Dominy et al., (2000), Johansen & Dominy (2005), Petersen & Dominy (2005), Cintra et al., (2007), Dominy (2014, 2017), Clark & Dominy (2017) and Dominy, Glass & Purevgerel (2022).



Fig. 1: PhotonAssay™ unit at Intertek Perth.

## 2. PhotonAssay™ Assay Technique

### 2.1 Introduction

The PhotonAssay™ method is a new non-destructive, rapid gold assay technique capable of analysing coarse (optimally <3 mm) 300–500 g samples at a rate of ~70 samples per hour (Figure 1; Tickner et al., 2017; Tickner, Preston & Treasure, 2018; Tremblay et al., 2019; Tremblay, Wheeler & Oteri, 2019; Tickner, 2021). Each PhotonAssay™ unit has the approximate dimensions of 6.1 m (W) by 7.3 m (D) by 2.7 m (H) and weighs 80 t.

The science behind PhotonAssay™ was developed by the Commonwealth Scientific and Industrial Research Organisation (CSIRO) in Australia, and the technology was developed and commercialised by Chrysos Corporation. Initial roll-out and validation was conducted in partnership with commercial laboratory groups.

The method is lead and cyanide free, hence adding substantial health and safety advantages. It can be widely applied across the full mine value chain inclusive of exploration (drilling and reconnaissance sampling), resource development (reverse circulation – RC and core drilling), grade control (RC and core samples; stockpile samples; underground samples), metallurgical testwork (head, tails and concentrate samples, and ore sorter testwork) and plant control (feed, process, solutions, carbon, concentrate and tails samples).

The method has also proven to be of utility during ore sorter testwork programmes, where it can be used to assay multiple samples of rejects and concentrates.

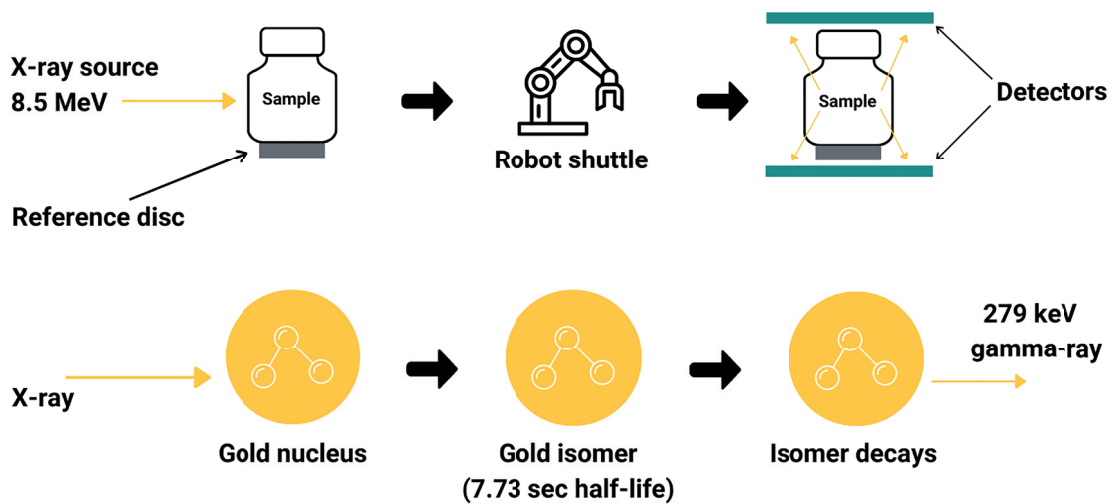

Credit: Chrysos Corporation; used with permission.

**Fig. 2:** Illustration of the PhotonAssay™ process.

### 2.1.1 PhotonAssay™ Technology

Based on the principles of *photon activation analysis*, the method uses a high-power, high-energy X-ray source to excite nuclear changes in any gold atoms present in a sample, followed by measurement of a characteristic signature emitted by these atoms (Figure 2).

Sample material is loaded into a sealed plastic jar in which it remains throughout the analysis (Figure 3). A removable reference disc is fixed to the outside of the jar.

The sample and reference disc is exposed to the same high-energy, high-intensity X-ray beam, typically for 15 seconds.

The high-energy X-rays induce nuclear changes in any gold atoms present in the sample, exciting their atomic nuclei into a short-lived state. When gold nuclei in the sample absorb the high energy X-ray photons created from the LINAC they are transformed into the  $^{197m}\text{Au}$  nuclear isomer. This species decays with a half-life of 7.73 seconds and emits a gamma ray of 279 keV.

The sample is transferred to a germanium detector station using a robotic shuttle. As the excited gold nuclei relax back to the ground state, they emit gamma rays with a characteristic 'gold energy'. The detectors record and count these gamma rays.



Credit: Chrysos Corporation; used with permission.

**Fig. 3:** Illustration of PhotonAssay™ process from left to right: sample jar registration and jar fill scanning; automatic feed of sample jars into the unit; and automatic outflow of jars from the unit.



Software then relates the strength of the gamma ray signal back to the concentration of gold in the sample, correcting for the sample mass, jar fill level and X-ray attenuation. The standard assay process is based on two cycles (PAAU02; Chrysos, 2022a), where the sample jar is irradiated twice (15 s each time) with the two values averaged to provide the reported grade. The basic flow of sample jars into the PhotonAssay™ unit is illustrated in Figure 3.

The reference disc contains a compound of the element bromine, which activates in a similar fashion to gold, but emits a lower energy 207 keV gamma ray. Measurement of the bromine activation signal serves as a reference that can be used to correct for any variations in the power of the X-ray source or efficiency of the detection system. This reference significantly improves measurement accuracy and allows each analysis to be directly tied back to calibration measurements performed on a suite of certified reference materials (CRM). This technique is relatively insensitive to assay material granulometry, thus rock chips or larger rock fragments can be measured. It is also insensitive to the sample matrix, so different rock types, process materials, solutions and carbon pulps can also be assayed.

X-ray levels outside of the unit are low so that operators can work safely without the need for special precautions. The short irradiation period and jar retention within the unit for two hours after measurement, ensures that residual sample activity is minimal. Jars can be safely handled, stored and/or reused as required.

### 2.1.2 PhotonAssay™ Parameters

The PhotonAssay™ measurement precision at one standard deviation (1SD) varies with grade (Table 1; Chrysos, 2022a). The lower detection limit (LDL) at 2SD is approximately 0.02 g/t Au to 0.03 g/t Au for typical samples. The upper detection limit is 350 g/t Au, though can be increased to 10,000 g/t Au as required (PAAU02H and PAAU02HH; Chrysos, 2022a). The above figures are based on the standard two-cycle assay process (PAAU02; Chrysos, 2022a).

Enhanced PhotonAssay™ performance can be achieved via the four- and eight-cycle assay process, where up to 1.4x and 2x improvements of the two-cycle LDL and precisions can be gained. The increased cycles take longer to complete and attract additional cost. For most purposes the two-cycle process is appropriate and cost effective.

The PhotonAssay™ methodology is relatively matrix insensitive, although significant levels of uranium, thorium, barium and lead decrease precision and increase the detection limit. Samples with uranium–thorium levels >5 ppm, barium >1,000 ppm and lead >2% start to show these effects, although gold can be measured in samples with much higher levels of these elements. Higher concentrations of interfering elements may not preclude assay, depending on needs.

In addition to gold, PhotonAssay™ can also determine silver and copper. Silver can be measured in the 1–2 g/t Ag to 10,000 g/t Ag range, and copper up to 30%.

**Tab. 1:** Performance parameters for fire assay compared to PhotonAssay™ (PAAU02).

Gold assay performance	Fire assay	PhotonAssay
LDL	0.005 g/t [ICP] 0.01 g/t [AAS] 0.05 g/t [gravimetric]	0.02–0.03 g/t
UDL	350 g/t Au [ICP] 100 g/t Au [AAS] 10,000 g/t Au [gravimetric]	350 g/t [PAAU02] 3,500 g/t [PAAU02H] 10,000 g/t [PAAU02HH]
Precision at 0.1–0.2 g/t Au	10%	10%
Precision at 0.35 g/t Au	5–8%	7%
Precision at 1.0 g/t Au	3–7%	4%
Precision at >10 g/t Au	2.5–3.5%	2.5%

The environmental impact parameters of PhotonAssay™ are an improvement on FA, where CO<sub>2</sub> emissions are 0.45 kg (0.91 kg for FA), hazardous waste is zero (0.31 kg for FA), and energy use is 0.65 kWh (1.3 kWh for FA) per assayed jar. Compared to FA, PhotonAssay™ is much quicker taking two to three minutes per jar compared to three to four hours.

### 2.1.3 PhotonAssay™ Calibration

PhotonAssay™ units are calibrated via the “k-cal” process at the start of each day or after a significant break in machine operation. Three jars containing synthetic crushed glass are run through the machine for 8 cycles each. The different glasses used in the jars have gold grades in the range 50–150 ppm. The glass is specially manufactured for Chrysos and was chosen because it is chemically and mechanically stable, not prone to settling, easy to manage and to transfer to new jars as required, and non-hygroscopic. However, it is not a certified material and must be calibrated before use.

### 2.1.4 PhotonAssay™ Data Outputs

Grade data from PhotonAssay is delivered via the relevant laboratory information system in an agreed format (e.g. .csv and/or PDF). Data generally provided includes: sample number, gold grade, assay error, and weight of sample in the jar. Specific codes may accompany a given result. The most common ones being: BDL (below detection limit); HB (high background related to high U, Th or Ba content); HET (heterogeneous sample related to high within sample variability); OVR (over-limit where the grade is above the upper limit of the measurement range – e.g. 350 g/t Au for PAAU02); IS (insufficient sample where the jar fill factor is <50%); and IE (interfering elements which could be Br or Er).

### 2.1.5 PhotonAssay™ Units in Operation

As of 30 September 2023, there were 22 PhotonAssay™ units deployed across the globe based in Australia, Africa and Canada (Chrysos, 2023b). A further 27 units are commercially contracted out to 2025 (Chrysos, 2023b).

Commercial laboratory operations include ALS, Perth and Kalgoorlie, Australia; Intertek, Perth, Australia; On-Site Laboratory Services, Bendigo, Australia; MSALABS, Prince George, Val d’Or and Timmins Canada; and SGS, Perth, Australia.

These laboratories cover regionally important goldfields in Western Australia; The Golden Triangle of BC, Canada; Abitibi Province of ON, Canada; and West Africa.

Early movers in the global mining industry to use PhotonAssay™ include Agnico Eagle Mines Limited (Fosterville mine, Australia), Barrick Gold Corporation (various global operations), Goldfields Ltd (Australia), Firefinch Limited (Morila mine, Mali), Newfound Gold Corporation (Queensway project, Canada), Northern Star Limited (various projects in Australia), Novo Resources Corporation (Beatons Creek and exploration projects, Australia), Alto Metals Ltd (Sandstone project, Australia) and Ravenswood Gold Limited (Ravenswood mine, Australia).

## 2.2 When Should the PhotonAssay™ Technique be Applied?

The choice of any sample preparation and assay protocol is up to the CP/QP based on consideration of the mineralisation in question and data quality objectives. The ultimate destination of the output data is also critical. In most cases this will be publicly reported and potentially included in Mineral Resource and Ore/Mineral Reserve estimates to be reported in accordance with one of the international codes (e.g. JORC, CIM, PERC, etc.). The key assay options are given in Table 2.

In theory the PhotonAssay™ technique can replace any of the methods listed in Table 2. However, there are over-rides for distinct reasons. If an investigation of the presence of coarse gold is required, then the SFA is valid, though PhotonAssay™ can be used to assay the SFA oversize and undersize. Where a proxy for cyanide metallurgical recovery is required, then LW or PAL are required. If mapping of gravity recoverable gold is required, then the SFA or GRAV approaches will be needed, though PhotonAssay™ is suited to the assay of residues from this process. If a large assay mass is applied (e.g. multiple PhotonAssay™ jars), then the variability of the jar group (e.g. 10 jars) may be correlated with gold particle size and gravity recoverable gold potential (Dominy & Graham, 2021).

In some cases there may simply be no advantage of changing to PhotonAssay™ as the current method is performing well and/or the laboratory setup is cost-effective, convenient and provides the required data quality objectives.

Tab. 2: Summary of gold assay methods.

Assay type	Assay charge	Nature of method	Application	Outcome
Fire assay (FA)	30–50 g	The standard method of fire assaying for gold	Small charge mass. Poor reproducibility in the presence of coarse gold	Grade
Screen fire assay (SFA)	0.5–5 kg	A variant of FA, the SFA reduces the coarse-gold problem by sieving out the coarse fraction (100–150 µm screens) and assaying it separately	An effective method for dealing with coarse gold. Can be used on samples up to 10 kg	Grade Per cent coarse gold
LeachWELL (LW)	0.5–5 kg	The method overcomes the problem of coarse particles by assaying the entire sample.  6–24 hours leach time effective for most coarse gold deposits	Large charge mass. Effective method for dealing with coarse gold. The method needs to be controlled by assaying the undissolved residues to check for partly dissolved gold	Grade Proxy leach recovery (if tails assayed)
Pulverise and leach (PAL)	0.5–1 kg	Essentially same as LeachWELL. Crushed (approx. P <sub>80</sub> –10 mm) sample is leached and pulverised at the same time  1–1.5 hour leach time	Smaller charge mass. Potentially effective method for dealing with coarse gold. Some issues relate to contamination of pulverise/leach pots. Method needs to be controlled by assaying the undissolved residues to check for partly dissolved gold	Grade Proxy leach recovery (if tails assayed)
Whole sample gravity processing	>50–500 kg	Takes large sample and processes entire via gravity (e.g. Knelson and/or Wilfley table) to produce a gold concentrate and tails for assay.  8–12 hours or more	Large charge mass. Effective method for dealing with coarse gold. Method needs to be managed to ensure maximisation of gold recovery Not useful for fine gold, unless gravity used for gold-rich sulphide concentration and/or clustered fine gold is present, hence larger sample warranted	Grade GRG (single or 3-stage) Proxy leach recovery (if tails leached) Gold particle size profile (if GRG screened)

Tab. 3: Sampling value chain. Refer to definitions of TOS errors in Appendix Table A1.

Location		Site / field			Laboratory
Node	Planning	Collection	Transport	Preparation	Assaying
<b>Activity</b>	Characterise Design Implement Write protocols Staff training	Observe Collect Bag and tag QA/QC Integrity/security Chain of custody	Integrity/security Chain of custody	Equipment operation Equipment clean QA/QC Integrity/security	Equipment operation Equipment clean QA/QC Integrity/security
<b>Sampling error</b>		FSE, GSE IDE, IEE, IWE	IPE	FSE, GSE IDE, IEE, iWE, IPE	FSE, GSE IDE, IEE, IWE, IPE
<b>Dominant effect on results</b>		Precision Bias	Bias	Precision (if splitting) Bias	Precision (if splitting) Bias

## 2.3 General Considerations of Using PhotonAssay™

### 2.3.1 Setting up a Programme

The same consideration for any drilling, sampling and assaying programme is relevant to the application of PhotonAssay™. All aspects of the sampling value chain must be considered, where all nodes of activity require optimum practice to ensure representative samples to support quality assay results (Table 3).

Discussions of the pros and cons of various drilling and sampling methods are provided in Dominy (2016), Lyman, Robertson & Day (2016), Dominy et al., (2018), Esbensen (2020), Esbensen et al., (2021) and Pitard (2019).

Where an existing project is looking to switch to PhotonAssay™, it can undertake a feasibility evaluation on applicability. At this stage, it is key for the CP/QP to have a clear understanding of the mineralisation in question and what the sampling and analysis requirements are.

A generic comparison protocol between existing assay results and PhotonAssay™ may look like:

- Select more than 150 coarse sample rejects whose original assay grade represent the grade distribution for a given domain;
- For each reject, crush to P<sub>80</sub> 2 mm (if required) and riffle split two equal 350–500 g portions, each to be placed in a PhotonAssay™ jar. PhotonAssay™ the two jars.
- Recombine both jars and pulverise to P<sub>80</sub> 75 µm and riffle split two equal 350–500 g portions, each to be placed in a PhotonAssay™ jar. PhotonAssay™ the two jars.
- From each jar of pulverised material, FA each to extinction – or least riffle split off two to four 30 g sub-samples. SFA or LW/PAL of each jar may be appropriate if coarse gold is suspected.

This protocol provides several conciliation points between the original assay, crushed material by PhotonAssay™, pulverised material by PhotonAssay™, effects of averaging two jars and a final direct comparison to FA (or SFA). The cost and environmental considerations must also be part of any feasibility study.

The alternative to undertaking a feasibility study is to design an optimised protocol using PhotonAssay™ and implement this across either an in-fill drilling programme or carefully re-sample and assay previous sample rejects.

Alternative assay methods for comparison can be embedded into the protocol. Such work needs to be designed and expedited by the CP/QP and is not simply a statistical process. A “smart” data-collaborative approach to optimisation is preferred that includes understanding the mineralisation and its sampling needs (Dominy, Xie & Platten, 2008; Dominy, et al., 2021; Dominy, Glass & Purevgerel, 2022; Pitard, 2015; Villanova, Heberle & Chieregati, 2017). Case studies 1 and 2 highlight this approach.

### 2.3.2 The Need for QAQC

For all assay programmes, QAQC are non-negotiable (Simon & Gosson, 2008). In practical terms, QC procedures monitor precision and accuracy of data, as well as sample contamination during preparation and assaying (Simon & Gosson, 2008). Resource and grade control drilling and assaying programmes will have a QAQC component, where the main considerations are:

- Duplicate field, laboratory and analytical samples.
- Insertion of CRMs and analytical blanks.
- Insertion of process blanks.
- Monitoring of sample crush and split quality.
- Submission of samples for umpire assay.
- Written and audited laboratory procedures with appropriate staff supervision to ensure compliance.
- Regular audits of the laboratory by the CP/QP.

Samples must be submitted for umpire assay by PhotonAssay™ followed by another method such as SFA or LW (with tails assay). All umpire work should be undertaken at a separate independent laboratory to the principal laboratory.

### 2.3.3 Certified Reference Materials

CRMs are used for both company QC purposes and by the laboratory operator/Chrysos for unit calibration and internal monitoring (Chrysos, 2023a).

PhotonAssay™ specific CRMs are now available, with the first being released by OREAS during 2021. Subsequently, in June 2023, 15 of the CRMs were issued new certification in which both the certified grade and SD changed (OREAS 2023a,b). The recertification was requested by Chrysos after OREAS had alerted Chrysos to customer feedback concerning statistically significant biases between observed and certified grades.

This related to a greater number of measurements being accumulated on more PhotonAssay™ machines than were available for the original certification. OREAS advised its known PhotonAssay™ clients to scrutinize any results generated by PhotonAssay™ during the period May 2021 to June 2023 (OREAS 2023a,b). The recertification involved 12 instruments operated by seven laboratories located in Australia, Africa and Canada compared to the 4-7 instruments operated by 3-4 laboratories located in only Australia for the original certification. The recertification reduced uncertainties to 1.5-2.5% for materials over 1 g/t Au and to 3-5% for materials below 1 g/t Au. The relative differences between the recertified and original certified values range from -1.6% to +5.1% with an average of +2.9%. The overall shift is attributed to improvements in calibration protocols introduced by Chrysos since the early round robins were undertaken. For the majority, 11 out of 15, of the CRMs the recertified grades are consistent with the 95% confidence interval of the original certification. For the remaining four CRMs, the average relative grade change of +3.8% places them outside the typical 2-2.5% upper 95% relative confidence interval. It is recommended that CP/QP's review the results of PhotonAssay™ programmes conducted within the time period of both sets of OREAS certifications. Reference is made to the OREAS website ([www.oreas.com](http://www.oreas.com)) for further information and relevant certificates.

Historically, PhotonAssay™ units have been calibrated against commercial CRMs, typically adopting the certified FA grades. This approach was followed as FA grades were considered to be the best estimates of the true gold content (compared to other existing analytical methods) and to ensure continuity with clients' earlier data sets obtained using FA. More PhotonAssay™ machines are now available for CRM round-robin evaluations, together with 'first-principles' materials prepared from high-purity gold and a blank substrate (e.g. "k-cal" process, see Section 2.1.3). This has led to some systematic deviations in FA grades becoming apparent, with a number of CRMs underreporting gold via FA by 2-3% compared to PhotonAssay™. This difference is attributed to a combination of: (a) the quoted FA grade uncertainty; (b) statistical uncertainty on the mean estimated PhotonAssay™ grade; (c) small systematic differences between the two methods e.g. lower FA recovery in refractory materials; and (d) small systematic differences between FA certification process followed by different manufacturers e.g. selection of laboratories, handling of outliers, etc.

The most effective calibration and monitoring comes from using materials with accurately certified PhotonAssay™ grades to generate consistent results. Mixing-and-matching FA and PhotonAssay™ certified grades can lead to issues, especially if by chance the selection of materials happens to show a mostly one-sided FA versus PhotonAssay™ difference.

The CP/QP should consult with the laboratory to agree on the use of CRMs for internal laboratory monitoring purposes. These CRMs should be inserted into client batches along with the client CRMs.

Chrysos recommend a monitoring CRM insertion rate of 5% (1 in 20), where CRMs should, as noted above be certified for PhotonAssay™ and cover a grade range of >0.3 g/t Au up to 80 g/t Au (Chrysos, 2022b, 2023).

It is important to ensure that PhotonAssay™ jars are filled above 50% or they will be rejected. A fill of >80% is optimal. Over time, settlement may occur within jars, particularly where pre-filled CRM jars are re-used. It has been noted that differences in fill proportion can lead to progressively biased results with time. This relates to situations where the CRM pulp fill settles with time but reports a high fill factor due to a "dusting" of fine pulp at the top of the jar thus recording the high fill factor when it may be low, even <50%. Also, it should be noted that when a CRM is first put through the PhotonAssay™ unit its mass and fill factor are recorded – these values are re-used each time the CRM is run and not determined on each use. Therefore if a CRM is used for six months, then its mass/fill value on first use is applied over the six months. It is therefore critical that CRM jars must be fully filled and their contents well packed in line with recommendations from Chrysos (2020; 2022b). Their fill levels and masses should be monitored on a weekly basis. Full re-jarring should be undertaken every four weeks. In any case, re-jarring should occur after c. 65 uses (assuming the standard two-cycle assay: PAAU02) as the X-rays lead to a deterioration of the plastic jar. Potential effects on the CRM with time are: loss of CRM material by leakage, damage or handling, and/or effects of moisture and/or oxidation.

#### 2.3.4 Disposal and Recycling of Jars

The storage and disposal of sample material is a key consideration for the CP/QP, who needs to consider the need for retention or not. In general, samples informing a new pre-operational project or resource development project should be retained. Samples related to grade control can more likely be disposed of. Given that PhotonAssay™ is non-destructive, analysed samples can be recombined for metallurgical or other testwork (Arrowsmith, Parker & Dominy, 2019; Dominy et al., 2023).

PhotonAssay™ jars and lids are made from polyethylene and so are suitable for recycling. Some groups are currently investigating the utility of robotic facilities to unscrew jar lids and clean them for re-use.

An average jar weighs 34 g, so a big assay programme could reach >1M jars comprising >34 tonnes of plastic, a factor to consider if samples are disposed to landfill.

Such a programme could also yield >400 t of jarred sample material. Various groups are trialing options for the re-use and/or recycling of PhotonAssay™ jars.

### 2.3.5 Positional Heterogeneity in Jars in the Presence of Coarse Gold

Samples containing coarse gold may display a positional heterogeneity when using PhotonAssay™. When a sample jar bearing coarse gold is presented to the PhotonAssay unit, a grade is determined based on the geometry between the coarse gold particle(s) within the jar, the detectors and X-ray source. If the jar contents are subsequently disturbed by movement (e.g. transport of the jar), then the relative location of gold particles may have moved, thus potentially providing a different grade on re-assay.

During a testwork programme undertaken on coarse gold mineralisation, 50 jars were assayed then “shaken” for 30 seconds and re-assayed. The re-assays displayed a bias of -3.9% between the original and re-assay grades, with a pairwise precision of ±19%.

The uncertainty estimated on the bias was 4.6%, which shows that the bias is not significant (<2SD). The heterogeneity effect increases the total measurement error (sampling and instrument) by a factor of c. 2% compared to the sampling only error (i.e. pretty much negligible). And if the sampling error is estimated empirically by comparing results for different aliquots drawn from the bulk lot, then this additional 2% contribution is already included.

With the style of mineralisation tested, higher variability was seen above 0.5 g/t Au, which is in accordance with other testwork that indicates coarse gold >250 µm at this grade and above and up to a few mm in size (Dominy & Graham, 2020; Dominy, van Roij & Graham, 2022).

This effect is only likely to affect coarse gold dominated mineralisation where a single dominant gold particle or unbroken gold cluster is present. It is highly unlikely to occur with every jar. In this case, ten PhotonAssay™ jars were averaged to yield a grade (Dominy & Graham, 2020). In the fine gold mineralisation example, the authors are aware of a similar experiment, which resulted in low bias (<0.5%) and high precision (<5%) values.

### 2.3.6 Assay Cost

The cost of PhotonAssay™ and associated sample preparation is dependent upon geographical location, laboratory, protocol applied and contract conditions with

the given laboratory. Based on analysis of selected “book prices” from Australian laboratories, the cost of PhotonAssay™ and other assays, with FA as the common denominator are presented. PhotonAssay™ (PA 500 g) yields 1.03x cost units (e.g. the same as FA), LeachWELL (LW 1000 g) 1.45x cost units, and screen fire assay (SFA 1000 g) 3.25x costs units. The reader is cautioned however, that this is a simple comparison that does not reflect contract-by-contract arrangements.

## 2.4 The Importance of “Rig-to-Assay” Optimisation

### 2.4.1 Fundamental Sampling Error evaluation

The FSE is dependent upon the Constitution Heterogeneity, which relates to sample weight, mineral fragment size and shape, liberation stage of the gold, gold grade, and gold and gangue density. It is the smallest residual sampling error that can be achieved even after *homogenisation* of a lot or a sample lot been carried to fulfilment, i.e. the material is in its intrinsic minimum residual heterogeneity state. When FSE is not optimised for each sub-sampling stage, it often becomes a major component of the sampling nugget variance (Francois-Bongarcon, 2004; Pitard, 2007, 2019; Dominy, 2014; Esbensen, 2020).

The FSE can be theoretically estimated before a lot of material is sampled, provided the sampling characteristics (e.g. the sampling constant - K) embedded in the FSE equation are determined (Gy, 1982; Pitard, 2019). The “FSE equation” can be used to optimise sampling protocols (Gy, 1982; Pitard, 2019), where it addresses key questions of sampling broken rock:

- What weight of sample should be extracted from a larger mass of mineralisation, so that the FSE will not exceed a specified variance?
- What is the possible FSE when a sample of a given weight is obtained from a larger lot?
- Before a sample of given weight is drawn from a larger lot, what is the degree of crushing or grinding required to lower error to a specified FSE?

Pitard (2013) states that the total allotted sampling error (TSE) for resource grade sampling should be less than ±32%. The component FSE should not exceed c. ±19–21% (over two to three sample reduction stages). Whilst a target FSE of less than ±21% is reasonable, it may be hard to achieve in the presence of coarse gold. A FSE target of ±30% may be more realistic.

In practice, the TSE may in general vary between  $\pm 20$ – $90\%$ , with typical components of field sampling ( $\pm 20$ – $90\%$ ), sample preparation ( $\pm 5$ – $40\%$ ) and analysis ( $\pm 1$ – $25\%$ ) (Stanley & Smees, 2007; Dominy, Purevgerel & Esbensen, 2020).

The use of the FSE equation represents a model approach that may, or may not, be a fully relevant match with geological reality, but which at least provides a starting point from where protocols can begin to be compared and optimised (Gy, 1982; Pitard, 2019). Reliable use of the FSE equation is critically dependent on that all ISE (and GSE) have been optimally eliminated or reduced (Pitard, 2019; Esbensen, 2020). Results of QC programmes will provide evidence for precision optimisation (repeatability) through application of field and laboratory duplicates (Stanley & Lawie, 2007; Stanley & Smees, 2007; Abzalov, 2008; Carswell et al., 2009; Dominy, Purevgerel & Esbensen, 2020). Sampling accuracy is dependent on the application of TOS ISE management rules along the complete lot-to-aliquot pathway (Esbensen, 2020). Further discussion and presentation of the FSE equation is provided in Gy (1982), François-Bongarçon (1998), François-Bongarçon & Gy (2002) and Pitard (2019). In the present contribution, the François-Bongarçon (1998) modified FSE equation is applied.

### 3. Case Studies

#### 3.1 Case Study 1: Examples of FSE estimation for the worst case scenario

##### 3.1.1 Introduction

An example is presented from an open pit operation, which is a well-characterised lode gold deposit with two distinct domains of sulphide mineralisation. One domain is dominated by  $<75 \mu\text{m}$  gold (D1), whereas the other is dominated by coarse gold  $>200 \mu\text{m}$  (D2). D1 sits on the footwall of D2, and is characterised by shearing, disseminated sulphides and minor quartz veining 10–15 m in width. D2 is a high grade (4–5 g/t Au) high-density quartz veining zone 5–10 m in width.

RC and diamond core drilling are used for resource development and grade control drilling. RC drilling accounts for c. 80% of all drilling on the site. Metallurgical and mineralogical sampling and testwork programmes have characterised the mineralisation in both domains, in particular, the nature of the gold particle size distribution. The D1 mineralisation has a sampling constant (K) of c. 5–150 g/cm, whereas the D2 mineralisation K range is 400–4,500 g/cm. The high D2 value is driven by the coarse nature of the gold ( $>100 \mu\text{m}$  to  $500 \mu\text{m}$ ).

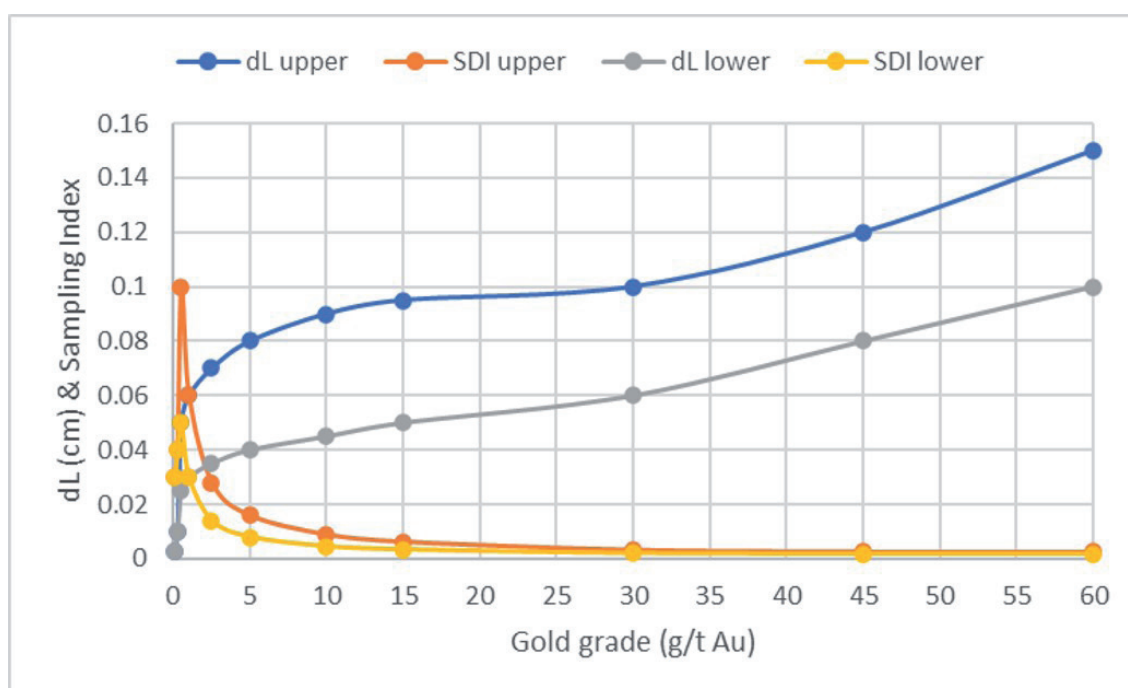

Credit: Simon Dominy; used with permission.

**Fig. 4:** Plot showing the relationship between gold grade and upper/lower gold particle sizing ( $d\ell$ ) for D2 mineralisation with the sampling difficulty index.

Figure 4 shows the relationship between gold grade and gold particle sizing in the D2 mineralisation ( $d\ell$  – liberation diameter: Pitard, 2019; Dominy et al., 2021). This is based on testwork, where the relationship presented shows the general trend of the data. The upper and lower  $d\ell$  values are shown for the given grade. The sampling difficulty index, i.e. ratio of  $d\ell$  with grade is defined such that any value  $>0.05$  may indicate sampling challenges. In this case, a grade of 0.5 g/t Au displays the worst case scenario.

The FSE calculations presented below are based on the mining (open pit) breakeven cut-off grade of 0.5 g/t Au, also given as the worst case scenario. Table 4 shows the original sampling protocol applied for each domain, with FSE analysis for D2 mineralisation.

FSE for the D1 mineralisation based on a 30 g FA, works well with an FSE of less than  $\pm 15\%$ .

For D2, the protocol is poor with a calculated total FSE range of greater than  $\pm 30\%$  and up to  $\pm 102\%$ . For the D1 protocol, the largest proportion of FSE relates to the pulp split, whereas the rig split becomes dominant in the D2 protocol.

The reader is reminded that the errors calculated here are solely the FSE, and no account is made for GSE, DE, EE or PE.

A revised protocol was subsequently recommended using PhotonAssay™ (Table 5).

For the revised protocol, the D1 protocol is acceptable with no change in the FSE. However, in the D2 protocol there is a worsening of the total FSE related to the splitting of 500 g for PhotonAssay™ from the 3 kg rig split. This is driven by the coarse nominal fragment ( $dN = 4.5$  mm) and gold particle size ( $d\ell = 500$   $\mu\text{m}$ ). The rig split is the same (3 kg from 35 kg). For the worst case, a rig split of c. 24 kg is required, followed by a lab split of 13 kg to achieve a  $\pm 30\%$  FSE (Figure 5).

The entire 13 kg could be assayed via PhotonAssay™ or crushed to c. 1 mm and 6.5 kg assayed maintaining an FSE of  $\pm 30\%$ .

Figure 6 shows the rig and lab mass splits required across the grade- $d\ell$  values previously noted. The highest mass requirements correlate with lower grades and the high sampling difficulty indices (Figure 4).

**Tab. 4:** Original sampling protocols applied for D2 with resulting FSE based on the low and worst case scenarios.

Protocol		Low case		Worst case	
Stage	Step	FSE	Rel. prop.	FSE	Rel. prop.
RC rig split	35 – 3 kg	$\pm 24\%$	49%	$\pm 79\%$	60%
Lab crush	3 – 1.5 kg	$\pm 19\%$	30%	$\pm 55\%$	30%
Pulverise & assay	1.5 kg – 30 g	$\pm 16\%$	22%	$\pm 32\%$	10%
Total	-	$\pm 34\%$	100%	$\pm 102\%$	100%

Rig split at  $P_{90}$  4.5 mm; laboratory splits at  $P_{90}$  3 mm; assay split as  $P_{90}$  75  $\mu\text{m}$ . Low case  $d\ell = 150$   $\mu\text{m}$  and worst case  $d\ell = 500$   $\mu\text{m}$ .

**Tab. 5:** Revised sampling protocols applied for D2 mineralisation, with resulting FSE based on the low to worst case scenarios.

Protocol		Low case		Worst case	
Stage	Step	FSE	Rel. prop.	FSE	Rel. prop.
RC rig split	35–3 kg	$\pm 24\%$	25%	$\pm 79\%$	29%
Lab crush & assay	3–500 g	$\pm 42\%$	75%	$\pm 124\%$	71%
Total	-	$\pm 48\%$	100%	$\pm 147\%$	100%

Rig split at  $P_{90}$  4.5 mm; laboratory splits at  $P_{90}$  3 mm. Low case  $d\ell = 150$   $\mu\text{m}$  and worst case  $d\ell = 500$   $\mu\text{m}$ .



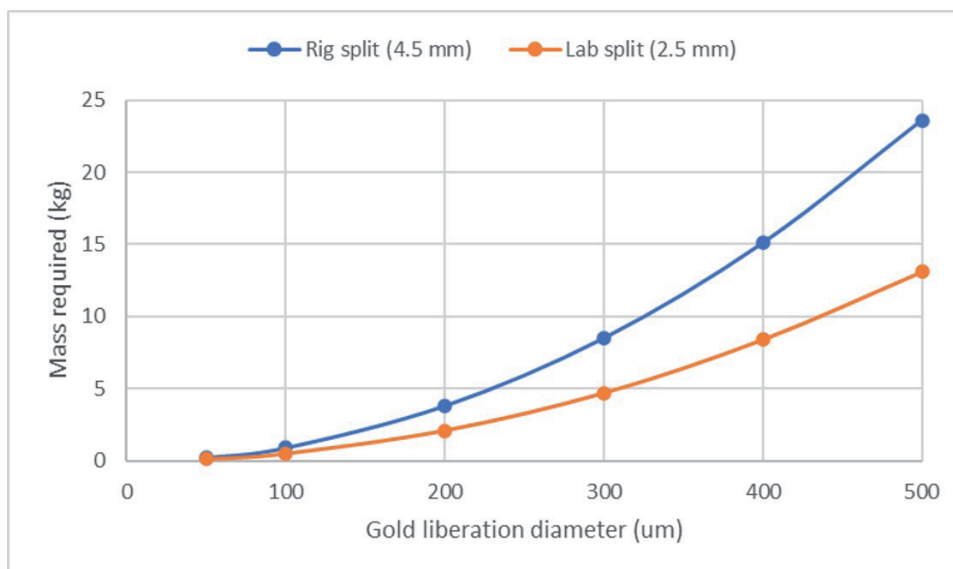

Credit: Simon Dominy; used with permission.

**Fig. 5:** Plot of mass required for the rig and laboratory splits at a grade of 0.5 g/t Au for various gold liberation diameters.

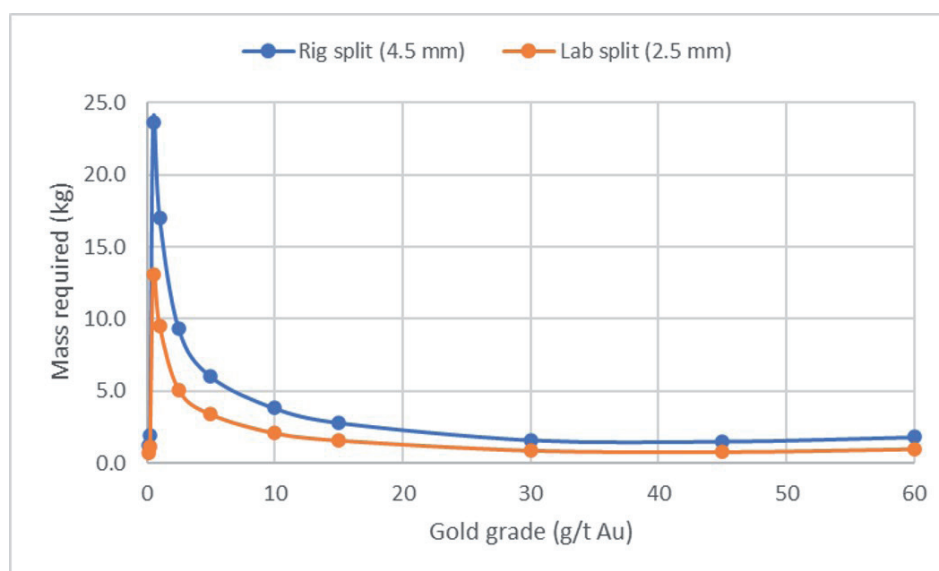

Credit: Simon Dominy; used with permission.

**Fig. 6:** Plot of mass required for the rig and laboratory splits at a series of grades based on the worst case gold grade- $d_l$  relationship presented in Figure 4.

**Tab. 6:** Revised sampling protocol applied to D2 mineralisation, with resulting FSE..

Protocol		Low case		Worst case	
Stage	Step	FSE	Rel. prop.	FSE	Rel. prop.
RC rig split	35 – 10 kg	±12%	30%	±24%	25%
Lab crush & assay	10 – 2.5 kg	±18%	70%	±42%	75%
Total	-	±21%	100%	±69%	100%

Rig split at  $P_{90}$  4.5 mm; laboratory splits at  $P_{90}$  3 mm. Low case  $d_l = 150 \mu\text{m}$  and worst case  $d_l = 500 \mu\text{m}$ .

The problematic grades lie between 0.3 g/t Au and 1.4 g/t Au, which includes the breakeven cut-off grade of 0.5 g/t Au.

A decision was made for further optimisation, specifically to take a 10 kg rig split followed by 2.5 kg at the laboratory for assay (Table 6). As before, the intention was to use PhotonAssay™, but the option exists to pulverise the entire 2.5 kg and assay via LeachWELL.

In this case, the calculated FSE for the worst case is high, though for the low case is acceptable.

### 3.1.2 Stage-wise error evaluation

Errors representing the repeatability of assay results can be estimated by pairwise analysis of field, coarse and pulp duplicates (Stanley & Lawie, 2007; Abzalov, 2008; Carswell et al., 2009; Dominy, Purevgerel & Esbensen, 2020). Sampling protocols include several stages of comminution and subsampling, where duplicates can be taken at every stage to allow estimation of the total sampling precision error and the relative contributions at the different stages of the sampling protocol (e.g. sampling, preparation and analysis error).

Stanley & Lawie (2007) and Abzalov (2008) have shown that the coefficient of variation, or the Relative Sampling Variability (RSV) estimated from paired data produces a reasonable estimate of sampling precision.

Component errors reflect the ore type, sample type and collection and proceeding preparation and analysis.

Total sampling error (as RSV) is likely to be in the range  $\pm 25$ – $100\%$  for gold ores, with components of  $\pm 20$ – $90\%$  (sampling),  $\pm 5$ – $40\%$  (preparation) and  $\pm 1$ – $25\%$  (analytical) respectively.

Throughout this contribution, the relative sampling precision from duplicate pairs is calculated via the RSV at 1SD (68% reliability). All data is filtered at the 10 $\times$  detection limit. All duplicates were collected as cascading pairs from the same field sample. Table 7 shows analysis for the original protocol.

The dominant error relates to the rig split, followed by the laboratory and pulp splits. The pulp split is high due to the presence of coarse gold related to delayed comminution. The reader is reminded that the duplicate errors include all errors: FSE, GSE, DE, EE, PE and AE. Table 8 shows analysis for the revised protocol (Table 6) based on the application of PhotonAssay™.

It should be noted that number of duplicates is low due to the recent introduction of PhotonAssay™. This data set displays a marked improvement from the original protocol. The total error, field/rig split is reduced from  $\pm 75\%$  to  $\pm 52\%$ .

For PhotonAssay™, the analytical RSV is provided as the jar or groups of jars can simply be re-assayed.

**Tab. 7:** Global pairwise precision estimate for the original D2 mineralisation protocol. Error provided as relative sampling variance (RSV).

	Field/ RC rig split RSV	Lab split RSV	Pulp RSV
Duplicate RSV	$\pm 75\%$	$\pm 49\%$	$\pm 26\%$
Stage RSV	$\pm 55\%$	$\pm 42\%$	$\pm 26\%$
Relative proportion	56%	32%	12%
Number of duplicates	350	350	350

**Tab. 8:** Global pairwise precision estimate for the revised D2 mineralisation protocol. Error provided as relative sampling variance (RSV).

	Field/RC rig split RSV	Lab split RSV	Analytical RSV
Duplicate RSV	$\pm 52\%$	$\pm 40\%$	$\pm 7\%$
Stage RSV	$\pm 33\%$	$\pm 39\%$	$\pm 7\%$
Relative proportion	51%	57%	2%
Number of duplicates	120	120	120

No splitting is required. In this case, an analytical RSV of  $\pm 7\%$  is acceptable.

### 3.1.3 Case 1 – Conclusions

Testwork during a Mineral Resource update displayed on improvement in the total nugget effect based on comparison between an area containing 300 holes of the original RC-FA, which was infilled with 125 holes assayed via the revised RC-PhotonAssay™ protocol. The original modelled nugget effect was 70% versus a reduced value of 50% which indicates the new PhotonAssay™ protocol is working. No change in geology or grade continuity was noted, suggesting that the reduction in total nugget relates to the SNE.

## 3.2 Case Study 2: Change from Fire Assay to PhotonAssay™ in a fine gold mineralisation

### 3.2.1 Introduction

In a second case study, a small shear-zone style open pit deposit contains minimal coarse gold. Drilling was by RC, originally using FA and then testing with PhotonAssay™.

For both programmes, the RC drilling produced c. 30 kg 1 m composites from which 3–4 kg were split at the rig. For the initial programme, the total rig sample was crushed at the laboratory to  $P_{80}$  2 mm and 1 kg split for pulverisation.

A 30 g charge was taken for FA. For the subsequent programme, the total rig sample was crushed at the laboratory to  $P_{80}$  2 mm and 500 g RSD split for a single PhotonAssay™ assay.

Table 9 shows the global pairwise precision estimate for the FA protocol. Table 10 shows the global pairwise precision estimate for the PhotonAssay™ protocol.

It can be seen from Table 9 and 10, that the dominant error (Stage RSV) in the protocols is the field/rig split at  $\pm 34\%$  and  $\pm 32\%$  absolute. As a relative proportion of the entire protocol these are 92% and 80% respectively.

There is some difference between the lab/coarse splits of  $\pm 9\%$  to  $\pm 16\%$ , which relates to the lab/coarse split changing from 3 kg to 1 kg (original) to 3 kg to 0.5 kg (revised). As a relative proportion of the entire protocol these are 6% and 19% respectively.

In the initial protocol, the pulp split yields a precision of  $\pm 5\%$  compared to the subsequent protocol of  $\pm 2\%$ . In the initial protocol, the precision includes both splitting and analytical errors. For the subsequent protocol, it represents the repeat assay of the same jar, effectively the analytical error.

**Tab. 9:** Global pairwise precision estimate for a low-coarse gold mineralisation via FA protocol. Error provided as relative sampling variance (RSV).

	Field/RC rig split RSV	Lab/coarse split RSV	Pulp RSV
Duplicate RSV	$\pm 35\%$	$\pm 10\%$	$\pm 5\%$
Stage RSV	$\pm 34\%$	$\pm 9\%$	$\pm 5\%$
Relative proportion	92%	6%	2%
Number of duplicates	240	240	240

**Tab. 10:** Global pairwise precision estimate for a low-coarse gold mineralisation via PhotonAssay™ protocol. Error provided as relative sampling variance (RSV).

	Field/RC rig split RSV	Lab/coarse split RSV	Analytical RSV
Duplicate RSV	$\pm 36\%$	$\pm 16\%$	$\pm 2\%$
Stage RSV	$\pm 32\%$	$\pm 16\%$	$\pm 2\%$
Relative proportion	80%	19%	<1%
Number of duplicates	125	125	125

### 3.2.2 Case 2 – Conclusions

This case study indicates that the switch to PhotonAssay™ in this instance did not add great advantage, based on precision of the sampling protocol. Testwork during a Mineral Resource update indicated no change to the nugget effect (c. 20%) based on comparison between areas of RC-FA and RC-PhotonAssay™.

In general, there are no barriers to the application of PhotonAssay™, other than high levels of interfering elements (e.g. U-Th, Ba and Pb). Additional advantages include reduced CO<sub>2</sub>, safer – no lead or cyanide used, and elimination of mix-ups and/or errors in the FA or analytical laboratory.

## 3.3 Case Study 3: Evaluation of different post-coarse crush splitting methods

### 3.3.1 Introduction

A key action in any protocol is the post-crush (coarse) laboratory split before assay. This is particularly important when using PhotonAssay™, as this is the split that feeds the PhotonAssay™ jars for direct assay. The general recommendation is that PhotonAssay™ uses a split of P<sub>80</sub> to P<sub>90</sub> 2 mm, though pulverisation is not precluded if appropriate.

Based on a moderately coarse gold mineralisation, testwork was undertaken to investigate the splitting of a 2.5 kg (5x PhotonAssay™ jars) composite assay charge.

Seventy-five 10 kg RC field samples were chosen based on their original assay value to ensure a representative range of grades greater than ten times the detection limit (>0.5 g/t Au).

The primary protocol was based on the crushing of 10 kg samples to P<sub>80</sub> 2 mm and RSD splitting of 2.5 kg from each. This 2.5 kg was placed in five PhotonAssay™ jars and assayed. From the selected retained residues, a further 2.5 kg sub-samples were split to from 75 RSD split pairs. The duplicate 2.5 kg splits were placed in five PhotonAssay™ jars and assayed.

Post assay, the two sets of 2.5 kg RSD splits were combined back with the 5 kg residue to form the “original” 10 kg sample.

These were poured in their entirety into a large tray, where two 2.5 kg splits were scooped from the 10 kg lot, placed in PhotonAssay™ jars and assayed. The scooping process can be likened to grab sampling along with its inherent errors (Gy, 1982; Dominy, 2010; Esbensen & Wagner, 2017; Pitard, 2019; Esbensen, 2020; Minnitt, 2022).

Table 11 shows the global pairwise precision for the original 2.5 kg PhotonAssay™ charge via RSD. The lab/coarse split stage RSV component is ±34%, representing 34% of the total protocol error.

**Tab. 11:** Global pairwise precision estimate for the original 2.5 kg PhotonAssay™ charge via RSD splitting. Error provided as relative sampling variance (RSV).

	Field/rig split RSV	Lab/coarse split RSV	Pulp RSV
Duplicate RSV	±59%	±35%	±7%
Stage RSV	±47%	±34%	±7%
Relative proportion	65%	34%	1%
Number of duplicates	75	75	75

**Tab. 12:** Global pairwise precision estimate for the second 2.5 kg PhotonAssay™ charge via scooping. Error provided as relative sampling variance (RSV).

	Field/rig split RSV	Lab/coarse split RSV	Analytical RSV
Duplicate RSV	±67%	±47%	±7%
Stage RSV	±47%	±46%	±7%
Relative proportion	50%	49%	1%
Number of duplicates	75	75	75

Table 12 shows the global pairwise precision for the repeat 2.5 kg PhotonAssay™ charge via scooping. The lab/coarse split RSV component is now  $\pm 46\%$ , representing 49% of the total protocol error. The scooping split has increased the overall RSV from  $\pm 59\%$  to  $\pm 67\%$ .

The scooping operation has increased the error focus onto the lab/coarse split stage, compared to using the RSD where the key error was associated with the rig split. The change from RSD to scooping effectively increases the stage RSV from  $\pm 34\%$  to  $\pm 43\%$  for the lab/coarse split process.

This increased error relates to the presence of coarse gold in the  $-2$  mm fraction, with gold particles up to  $500\ \mu\text{m}$  in size observed. Eight of the 75 2.5 kg assay charge samples with grades  $>0.5$  g/t Au were panned to check for visible gold, with both gold in rock particles and minor free gold observed.

### 3.3.2 Case 3 – Conclusions

This case study shows clearly that the laboratory/coarse sample split must be undertaken correctly to minimise sampling errors. The original protocol where the rig/field error dominates, swaps in the second protocol due to the dominant laboratory/coarse split error due to scooping. Note the limitation of this study is that only 75 sample pairs were used, that being a practical number given the effort involved.

The general paradigm for PhotonAssay™ is to crush to  $P_{80-90}$  2–3 mm and split into the relevant number of jars. This split size and mass must be optimised to reduce the FSE and the correct splitter used to minimise bias. Riffle or RSD type splitters are appropriate as either bench top or automated (e.g. Boyd or Orbis crushers and associated splitters) units (Petersen, Dahl & Esbensen, 2004; Esbensen & Wagner, 2017; Pitard, 2019; Esbensen, 2020). Like any piece of sampling equipment, an RSD or riffle splitter must be set up properly and operated correctly. Any kind of scooping or grabbing is likely to lead to enhanced bias. Crush quality and split precision must be monitored as part of the QC process.

Arguments against the laboratory use of an RSD usually focus on greater time and higher cost requirements. The CP/QP needs to weigh up the pros and cons. A riffle splitter is an effective, quicker and cheaper option.

## 3.4 Case Study 4: Calibration of gold ores

### 3.4.1 Background

In the context of broken rock, the FSE is the smallest residual error that can be achieved even after homogenisation of a sample lot is attempted (Gy, 1982; Pitard, 2019). The FSE is dependent upon the constitution heterogeneity, which relates to sample weight, mineral fragment size and shape, liberation stage of the gold, gold grade, and gold and gangue density. The FSE can be estimated before the material is sampled, provided the sampling characteristics (e.g.  $K$  and  $\alpha$ ) embedded in the FSE are determined. Heterogeneity tests lead to the calibration of  $K$  and  $\alpha$  and back-calculation of the liberation diameter –  $d_l$  (Minnitt, Rice & Spangenberg, 2007; Minnitt & Assibey-Bonsu, 2009; Pitard, 2015; Minnitt, Francois-Bongarçon & Pitard, 2017; Villanova, Heberle & Chieregati, 2017; Dominy et al., 2021; Chieregati et al., 2023).  $d_l$  can be equated to  $d_{Au95}$  – effectively the screen size that retains 5% of gold given a theoretical lot of liberated gold. Where gold particles cluster, the  $d_l$  becomes  $d_{lclus}$ , which is the equivalent spherical diameter (ESD), or the composite particle formed by the cluster group (Dominy & Platten, 2007).

There are several different types of heterogeneity test, which in the simplest sense are the standard Heterogeneity Test (HT; Gy, 1982) and the Duplicate Series Analysis (DSA; Minnitt, Rice & Spangenberg, 2007) and variants. The key outputs of such test are the sampling constant ( $K$ ) and so-called alpha ( $\alpha$ ). The standard heterogeneity test attempts to isolate the FSE, whereas the DSA estimates the first component of the quality fluctuation error (QFE1), i.e., the FSE plus the grouping and segregation error (GSE). Debates have taken place addressing the limitations of the various approaches and the true nature of variability measured in heterogeneity experiments. To date, there is no agreement on which approach is correct. However, for heterogeneous mineralisation such as gold, a more integrated approach using various inputs (e.g. metallurgical test-work, mineralogy/mineral deportment and field observations) may be appropriate (Pitard, 2015; Villanova, Heberle & Chieregati, 2017; Dominy et al., 2021; Chieregati et al., 2023).

PhotonAssay™ provides an excellent methodology for the analysis of material for heterogeneity testwork (Tremblay, Wheeler & Oteri, 2019). Its non-destructive nature allows for additional verification work through metallurgical and/or X-ray tomographic approaches. Some preliminary studies are reported below.

### 3.4.2 Calibration by DSA

A DSA calibration approach was used on a mineralisation type known to contain coarse gold. The mineralisation is characterised by quartz-sulphide veins with free gold associated with the sulphides, with an underground run-of-mine grade in the 14–16 g/t Au range. Based on knowledge at the time, it was estimated that 350 kg was required to be collected from the plant feed belt ( $P_{80}$  80 mm) to achieve  $\pm 20\%$  FSE at the 1SD confidence limits. A primary lot of run-of-mine was collected as a series of increments from the plant feed belt over a single process shift of 12 hours (c. 400 tonnes of ore feed). The increments were collected by stopping the belt 24 times over the 12 hour period, effectively at random within each 30 minute period. Each 15.5 kg increment was manually cleared from the belt.

The DSA methodology and associated outputs of Minnitt, Rice & Spangenberg (2007) were followed. The global value for K was 225 g with an  $\alpha$  value of 1.3. The back-estimated  $d_l$  value was 110  $\mu\text{m}$ . The K and  $d_l$  values were estimated for each size fraction based on the work of Lyman (2019; 2023).

Assuming traditional values of 0.25 for the granulometric factor and 0.5 for the shape factor (sphere), the effective top size of the particles/clusters can be back-estimated (Lyman, 2019; 2023). The results are given Table 13.

In the coarsest fraction [1], the gold particles cluster to 750  $\mu\text{m}$ , though as comminution progresses the particle reduces to 125  $\mu\text{m}$ .

Figure 7 shows the reduction in effective gold size with nominal particle size.

The recognition of gold clusters is consistent with core logging and underground mapping, where composite clusters (including quartz-sulphide material between individual gold particles) of a few mm to 2 cm are observed. Clustering is material to any part of the sampling process where they exist, from in-situ rock to crushed material (Dominy & Platten, 2007; Dominy et al., 2021; Dominy, Glass & Puregerel, 2022).

**Tab. 13:** Calculated values of K and  $d_l$  for gold mineralisation using PhotonAssay™.

Series	1	2	3	4
dN nominal size (mm)	25	3	1	0.5
K (g)	65	2	1	0.6
$d_l/d_l\text{clus}$ ( $\mu\text{m}$ )	750	225	190	125

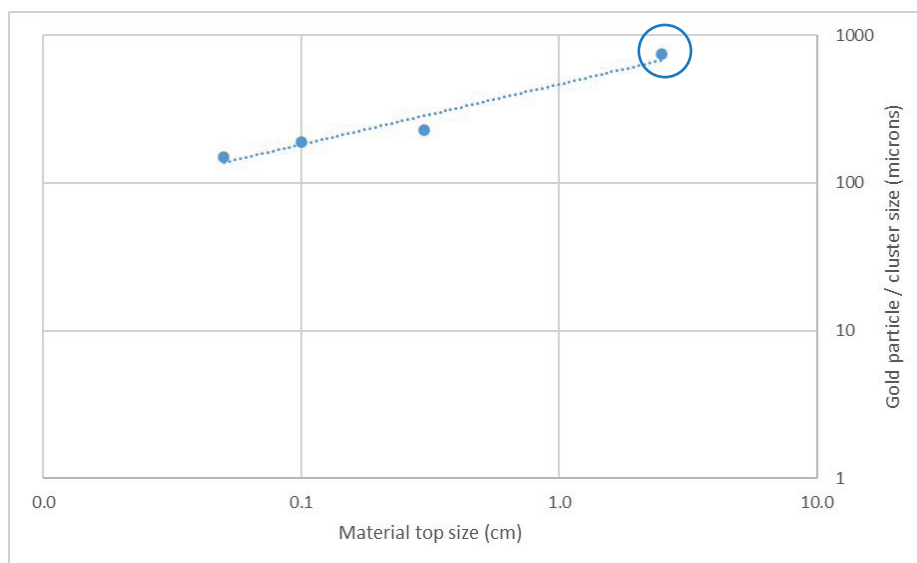

Credit: Simon Dominy, used with permission.

**Fig. 7:** Estimated size of gold clusters as a function of sample nominal size. The cluster size within 2.5 cm sized material is 750  $\mu\text{m}$ .

### 3.4.3 Direct calibration via testwork and X-ray computed tomography

As part of a validation study presented in the previous section, PhotonAssay™ jar contents were subjected to X-ray computed tomography (XCT) to resolve gold particle size (Howard et al., 2011; Dominy et al., 2012; Kyle & Ketcham, 2015; Dominy et al., 2021). Samples were scanned as a series of lots, with the final gold particle size data combined for analysis. The effective resolution of the XCT was 50 µm.

Following the XCT study, each set of jars were recombined as one sample and subjected to a crush-liberation-gravity (CLG) concentration process. At each of three stages, the gold was concentrated via Mosely Table and/or spiral panner and the gold particle sizes measured. Table 14 reports the DSA (Sample #7 only), CLG and XCT results compared to the core logging (GEO).

**Tab. 14:** Results for samples assayed by PhotonAssay™, scanned by XCT and processed via CLG. [--] values represent composite gold particle size of cluster. Non [--] values represent single particle size. All particle sizes as ESD.

Sample No.	PhotonAssay™ bulk grade (g/t Au)	Nominal max. particle size (mm)	Total mass (kg)	DSA d <sub>l</sub> (µm)	CLG d <sub>l</sub> (µm)	XCT d <sub>l</sub> (µm)	GEO d <sub>l</sub> (µm)
1	0.5	5	5	-	70	-	-
2	1.7	5	5	-	100	150	-
3	3.2	5	5	-	135	-	-
4	5.5	5	5	-	160	[550]	[400]
5	8.4	5	5	-	125	[600]	[700]
6	10.6	5	5	-	470	[350]	[1,250]
7	15.2	5	5	110 [750]	350	[1,050]	[1,650]
8	26.5	5	5	-	540	[1,350]	[1,800]

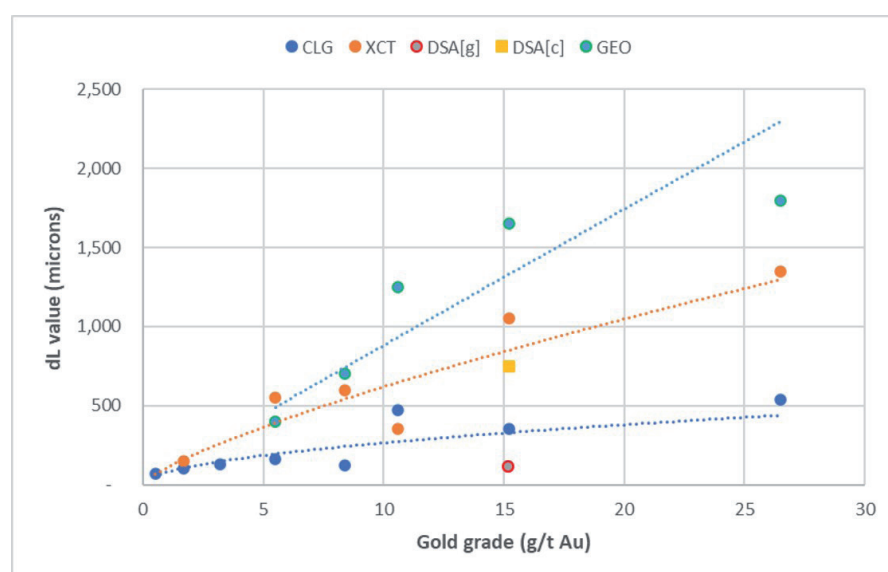

Credit: Simon Dominy; used with permission.

**Fig. 8:** Gold particle size data from the DSA, CGL and XCT analysis. GEO: Geological logging of core; CLG: Crush-liberate-gravity; XCT: X-ray computed tomography; DSA: Duplicate series analysis, [g] global d<sub>l</sub> and [c] clustered d<sub>l</sub>.

The particle size data from Table 14 is presented in Figure 8.

The CLG data provide a non-clustered  $d_l$ , given that the gold is liberated, and clusters destroyed. The XCT data was scanned at a 2.5 cm nominal size and has thus resolved any clustering present at that scale. The cluster values presented represent a single particle composited from the cluster group. The value from geological logging of core (GEO) is a generic observation of clusters from core intersections of the same grade as the samples – it is not from the actual samples.

The DSA results for sample #7 represent a mathematical manipulation of assays rather than a direct measurement of gold particles. The approach has identified the possibility of clustering ( $d_l = 750 \mu\text{m}$ ) which is confirmed by geological observation ( $d_l = 1,460 \mu\text{m}$ ) and XCT scanning ( $d_l = 1,050 \mu\text{m}$ ). Whilst the  $d_l$  values are different, the XCT represents a scanned sub-set of the original DSA lot (5 kg versus 15 kg), and the geological observation is not from the same lot but from the same mineralisation.

The definition of  $d_l$  versus  $d_{l_{clus}}$  is a different proposition across available methodologies. The DSA is an averaging process that is dependent upon the representativity of the original sample lot. The largest cluster values relate to geological logging of core which are more representative over 1,000's m of core but may be biased high as the measurement of the composite particle ESD is based on human interaction with the core, e.g. hand lens and ruler and stereographic effects (e.g. 2D observation of the core surface).

The best evaluation of clusters comes from XCT, given that a direct measurement is taken and that the composite size can be better evaluated in 3D (Dominy et al., 2021). Though like all methods, XCT also has its limitations in particular interferences between gold particles (e.g. star and streak effects: Howard et al., 2011; Kyle & Ketcham, 2015).

#### 3.4.4 Case 4 – Conclusions

The calibration data in Case 4 emphasises the need to crush drill core to 2 mm to minimise the effect of clustering on subsequent splitting.

A post-testwork analysis shows that the selected 350 kg DSA primary sample mass was reasonable, yielding an FSE of  $\pm 19\%$  based on a  $d_{l_{clus}}$  of  $750 \mu\text{m}$ , grade of 14 g/t Au and  $\alpha$  of 1.3. If the highest  $d_{l_{clus}}$  value of  $1,650 \mu\text{m}$  (from GEO, Table 13) is applied, then the FSE rises to  $\pm 36\%$ . A major challenge with calibration tests such

as the DSA, is the representativity of the sample mass selected.

In coarse gold environments assumed masses may be unrepresentative, placing doubt on test results (Pitard, 2015; Villanova, Heberle & Chierigati, 2017; Dominy et al., 2021; Chierigati et al., 2023). In this case, the high grade of the ROM plant feed reduced the mass required.

If the mine cut-off grade (3.5 g/t Au) was targeted, then the required mass is likely in the range of 0.5–1 t. This raises the question as to the most appropriate grade to optimise to. Given the importance of the mine cut-off grade, this should perhaps be the target for calibration (Dominy & Xie, 2016; Dominy, Glass & Purevgerel, 2022).

Where possible, *a priori* data should be used during planning to investigate the representative sample mass required and post-calibration for validation of results (Pitard, 2015; Villanova, Heberle & Chierigati, 2017; Dominy et al., 2021; Chierigati et al., 2023).

A single DSA test was undertaken, raising the question of repeatability. Such tests (e.g. DSA or HT) are rarely duplicated given their cost and complexity. However, where repeats on the same mineralisation have been undertaken, in the experience of the authors, the results are often quite different. In addition, care must be taken during interpretation of the results, as it is unlikely that the calculated K value is constant through a given mineralisation style or domain(s) (Dominy, Glass & Purevgerel, 2022). If a low value of K is selected then a protocol may be inappropriate, and alternatively if a high K value is selected the protocol may be too complex and costly. This emphasises the need to determine the critical grade(s) at which optimisation should take place.

PhotonAssay™ offers capability for repeat calibration experiments when combined with an automated fragment group selector such as that proposed by Prado et al., 2024. In this case, the standard (grouped) heterogeneity test is used (Dominy & Xie, 2016; Pitard, 2019; Chierigati et al., 2023). The screened calibration sample is passed through an automated system that selects fragment-by-fragment 50 groups for assay. The advantage with the non-destructive PhotonAssay™ method, is that groups can be assayed and then recombined for repeat tests on the same material.

Post-testwork, the company is continuing to consider the use of PhotonAssay™. Currently, it crushes whole 1 m ( $\pm 0.2$  m) NQ2 core composites (approx. 4.5–6.5 kg) to P80 2 mm, rotary splits off 2 kg, which is entirely pulverised and split into two 1 kg lots for SFAs.



## 4. Discussion

Sampling errors across the mine value chain generate both monetary and intangible losses. At the project development stage these losses can relate to biased resource/reserve estimates, potential project delay and/or wasted/misused capital. During mine operation, issues principally relate to ore/waste misclassification and poor reconciliation. In all cases, there are monetary costs in correcting protocols. Getting sampling correct the first time is a convincing activity.

PhotonAssay™ is a significant development in the gold assaying field. It is a novel X-ray method that provides fast, accurate, fully automated and non-destructive measurements on large samples. The method is agnostic to material composition and granulometry. No chemicals are used, and no waste produced, other than the sample material that can be stored or used again as required. PhotonAssay™ provides faster turnaround times and lower costs than most analytically competing approaches. Sample material does not require pulverising and can be assayed in a crushed form, generally P80-90 2-3 mm. This provides distinct advantages in terms of time and cost. The method has been ISO/NATA certified, and results have been included in Exploration Results and Mineral Resource/Reserve estimates reported in accordance with the JORC Code and NI 43-101 (Dominy et al., 2022).

Whilst this paper has focused on the sampling of diamond core and RC chips, the discussions are relevant to all sample types, including those used in the underground environment (e.g. chip or channel samples) and/or metallurgical samples (Dominy, 2017; Dominy et al., 2018a,b; Dominy et al., 2023).

Based on the review of data for several global projects, the authors note that for fine gold mineralisation (<100 µm) the agreement between FA30 and PA500 is good, with grades below 10-15 g/t Au displaying an agreement with ±10%. In some cases, this agreement may increase to more than ±10% if the effect of very minor coarse gold comes into play. Similarly, in the case of coarse gold-bearing mineralisation (>100 µm), the agreement between FA30 and PA500 is likely to be greater than ±20% given the inherent heterogeneity of the mineralisation. Where PA500 is compared to SFA1000 the agreement is reasonable and within ±20%.

Based on Case Study 1, where D1 mineralisation contains fine disseminated gold, PhotonAssay™ adds no significant advantage though allows larger samples to be obtained with reduced sample preparation. For coarse gold mineralisation, such as the D2 mineralisation, PhotonAssay™ of a larger assay charge size using multiple jars is advantageous.

Pulverisation can be applied to reduce the gold particle size and hence the FSE if required. However, care must be taken to avoid gold loss/smearing (PE) and/or promoting GSE.

The practitioner must review the entire “rig-to-assay” process, as simply increasing the assay charge size may not provide the error improvement desired. The primary rig-splitting error may pervade the process. Similarly, the post-crush split in the laboratory may also carry a significant error.

Coarse-gold assaying with FA is flawed (Royle, 1989; Pitard & Lyman, 2013; Dominy, 2014; Dominy, 2017; Dominy et al., 2017; Lyman, Robertson & Day, 2016; Pitard, 2017). The approach is prone to high ISE and CSE, particularly when the assay charge is scooped from the pulp (Dominy, 2016; Minnitt, Dominy & Esbensen, 2022). The propensity of gold not to pulverise efficiently potentially promotes high FSE and GSE effects during sub-sampling for the FA charge.

A whole sample assay method like the PhotonAssay™ offers an optimised alternative to most currently competing analytical approaches. Inappropriate sampling protocols for coarse gold-bearing mineralisation will unavoidably lead to strong bias and poor precision. Protocols may involve pulverisation of an entire sample, which results in gold liberation. In such cases, sample splitting becomes a critical success factor, and will be highly problematic other than with a riffle splitter or RSD. Any attempt at ‘homogenisation’ will be useless and will promote GSE instead. Mat mixing or scooping from a pile of pulp or pulveriser bowl, should be avoided with extreme prejudice (Minnitt, Dominy & Esbensen, 2022). There is no escaping the general conclusion that a large-sample assay method such as PhotonAssay™ is likely to be optimal in the presence of coarse gold.

Future application of PhotonAssay™ will see it integrated into workflows that develop total deposit knowledge in support of geometallurgical programmes. Whilst its analytical capability is currently limited to gold, gold-silver and copper, scanning of the jars by micro-XRF, XCT and spectral sensors will add value. Pre-jarring determinations may include sub-sampling for other assays or tests. The non-destructive nature of PhotonAssay™ allows assayed material to be recombined for other assays or tests across the mineralogical, geochemical, geoenvironmental and metallurgical domains (Arrowsmith, Parker & Dominy, 2018; Dominy et al., 2023). Aspects of the workflow may well be automated. The relevance of real-time data is becoming important to drive more efficient and cost-effective operations globally. Workflows including PhotonAssay™ will contribute to this need. The application of TOS is paramount to achieve quality data through representative samples.

## 5. Recommendations for the Practitioner

- The CP/QP needs to act and not simply accept “standard” or so-called “best practice” protocols and methodologies for the sampling of gold mineralisation, particularly in the presence of coarse gold. The optimisation of a sampling protocol comes from understanding the mineralisation and desired programme outputs. It is not simply a mathematical, or a statistical process but a complex process taking advantage of orebody knowledge and application of TOS. Follow the general lot-to-aliquot stipulations of first eliminating all ISE effects before addressing GSE and FSE. Then use duplicate pair analysis to assess on-going performance.
- Sampling protocol design must consider programme aim and objective(s) in context of the mineralisation type. In most cases, a dedicated characterisation programme is required to support realistic application of TOS. A “smart” data-collaborative approach to optimisation includes understanding the mineralisation and its sampling needs (Dominy, Xie & Platten, 2008; Dominy, et al., 2021; Dominy, Glass & Purevgerel, 2022; Pitard, 2015; Villanova, Heberle & Chierigati, 2017). Characterisation must start as soon as mineralisation is encountered by outcrop (surface or underground) and/or drilling. Characterisation with respect to gold particle sizing, mineralogy and heterogeneity is critical. Detailed core logging and/or geological mapping will reveal much about the presence of coarse gold and clustering. Initial assaying campaigns should utilise SFA to identify the presence of coarse gold. Preliminary  $d_{80}$  and/or  $d_{10}$  values may be estimated.
- In the coarse gold environment, calibration approaches such as the HT or DSA are likely to be inappropriate due to the selected primary mass being unrepresentative. Similarly, the results of repeat or multiple tests, which are seldom undertaken, may show substantial differences (Dominy & Xie, 2016; Dominy, 2016; Dominy, Glass & Purevgerel, 2022). Where possible, a priori data should be used during planning to investigate the representative sample mass required and post-calibration for validation of results. In addition, care must be taken during interpretation of the results, as there is no guarantee that the calculated K value is constant through a given mineralisation style or domain(s), notwithstanding changes in grade. This again emphasises the need to determine the critical grade(s) at which optimisation should take place.
- A well-drilled and collected RC sample provides a large mass (>30 kg/m versus 4–8 kg/m for diamond core). Larger splits at the rig are required, supported by a larger assay charge. The CP/QP must consider the relative pros and cons, and design an appropriate “rig to assay” protocol.
- Whole diamond core sampling followed by full sample assay via PhotonAssay™, SFA, LW or PAL may be required in some cases. This effectively yields zero FSE and GSE values. Arguments against whole core sampling revolve around no reference core remaining, though with modern digital photography, geochemical and spectral sensors, and detailed logging this should not be an issue.
- During mass and sample size reduction at any stage of the process, the split size and mass must be empirically optimised to reduce the FSE, and the correct splitter used to minimise bias. Riffle or RSD type splitters are appropriate as either bench top or automated units (Petersen, Dahl & Esbensen, 2004). Like any piece of sampling equipment, an RSD or riffle splitter must be set up properly and operated correctly (Petersen, Dahl & Esbensen, 2004; Esbensen & Wagner, 2017; Esbensen, 2020). Any kind of scooping or grabbing is likely to lead to high bias. Crush quality and split precision must be monitored as part of the QC process.
- Conducting systematic QC programmes to measure the reliability of each of the sampling, preparation and assaying steps and then optimise the process. QC cannot be divorced from the TOS and is a mandatory step in representative fit-for-purpose sampling. Proper documentation, staff training and periodic peer review are required. Full and open communications are required with laboratory service providers – the CP/QP must visit the laboratory.
- There is a need, and a clear advantage, in moving towards full quantification of errors for objective QC assessment, where a first step is the application of the RSV sampling plus analysis variability characteristic as defined in DS3077 (2013; 2024). Resolution of individual relative errors across the complete sampling, preparation, and analysis stages can be gained from duplicate sample pairs.

## ACKNOWLEDGEMENTS

Craig Hamlyn (Ore Research & Exploration Pty Ltd) is thanked for pointing out ambiguous statements regarding, and constructive discussions of, the reasons behind recertification of OREAS CRMs, which led to the release of a revised version of the paper. SST regrets the inconveniences caused by this.

Several mine operators and laboratory service providers are thanked for their support and input into this work. The following groups are particularly acknowledged: Chrysos Corporation, MinAnalytical (now ALS Group), Intertek, MSALABS Ltd, OCX Gold Group and Novo Resources Corporation. Dr James Tickner (Chrysos Corporation), Professor Richard Minnitt (University of Witwatersrand, RSA) and Professor Ana Chieregati (University of Sao Paulo, Brazil) are thanked for their reviews and comments on this contribution.

## References

- Abzalov, M. Quality control of assay data: a review of procedures for measuring and monitoring precision and accuracy. *Explor. Mining. Geol.*, 2008, 17, 131–144.
- Arrowsmith, V.; Parker, B.; Dominy, S.C. Beatons Creek conglomerate gold project, Pilbara, WA: sulphide mineralisation metallurgical testwork report. Unpublished internal report, Novo Resources Corporation, 30 April 2019, pp. 69.
- Carrasco, P.; Carrasco, R.; Jara, E. The economic impact of correct sampling and analysis practices in the copper mining industry. *Chemom. Intell. Lab. Syst.* 2004, 74, 209–213.
- Carswell, J.T.; Yulia, K.; Lesmana, D.; Steamy, K. Grade control sampling quality assurance/quality control in a high-grade gold mine – Gosowong, Indonesia. In *Proceedings of the International Mining Geology Conference; Australasian Institute of Mining and Metallurgy: Melbourne, Australia, 2009; pp 285–290.*
- Chieregati, A.C.; Prado, G.C.; Fernandes, F.L.; Villanova, F.L.S.P.; Dominy, S.C. A Comparison between the standard heterogeneity test and the simplified segregation free analysis for sampling protocol optimisation. *Minerals*, 2023, 13, 680.  
<https://doi.org/10.3390/min13050680>
- Chrysos, 2020. Procedure for Re-jarring Certified Reference Material (CRM) Jars. Work Instruction: WI-023 – Re-jarring CRMs. Chrysos Corp. internal report, dated April 2020, Version 1. pp. 3.
- Chrysos, 2022a. Performance Note PN-001: Chrysos PhotonAssay™ Measurement Performance for PAAU02. Chrysos Corp. internal report, dated April 2022. pp. 2.
- Chrysos, 2022b. Technical Note TN-401: QAQC Procedures for Chrysos PhotonAssay™ Systems. Chrysos Corp. internal report, dated December 2022, Version 1. pp. 9.
- Chrysos, 2023a. Technical Note TN-003: Chrysos PhotonAssay™ Monitoring Standard Recommendations. Chrysos Corp. internal report, dated March 2023, Version 2. pp. 5.
- Chrysos, 2023b. Chrysos Corporation Q1 Financial Year 2024 – Quarterly Investor Update. Chrysos Corp. investor presentation, dated 26 October 2023, pp. 19.
- Cintra, E.C.; Scabora, J.A.; Viegas, E.P.; Barata, R.; Maia, G.F. Coarse gold sampling at Sao Francisco mine, Brazil. In *Proceedings of the World Conference on Sampling and Blending, Porto Alegre, Brazil, 23–25 October 2007; Fundacao Luiz Englert: Porto Alegre, Brazil, 2007; pp. 187–197.*
- Clark, I.; Dominy, S.C. Underground bulk sampling, uniform conditioning and conditional simulation – unrealistic expectations. In *Proceedings of the Eighth World Conference on Sampling and Blending. Australasian Institute of Mining and Metallurgy: Melbourne, Australia, 2017; pp. 3–19.*
- Dominy, S.C. Grab sampling for underground gold mine grade control, *J. South. Afr. Inst. Min. Metall.*, 2010, 110, 277–287.

- Dominy, S.C. Predicting the unpredictable – evaluating high-nugget effect gold deposits. In *Mineral Resource and Ore Reserve Estimation Guide to Good Practice*; Australasian Institute of Mining and Metallurgy: Melbourne, Australia, 2014; pp. 659–678.
- Dominy, S.C. Importance of good sampling practice throughout the gold mine value chain. *Mining Tech.* 2016, 125, <https://doi.org/10.1179/1743286315Y.0000000028>
- Dominy, S.C. Sampling coarse gold-bearing mineralisation – developing effective protocols and a case study from the Ballarat mine, Australia. In *Proceedings of the World Conference on Sampling and Blending*, Perth, Australia, 9–1 May 2017; Australasian Institute of Mining and Metallurgy: Melbourne, Australia, 2017; pp. 71–84.
- Dominy, S.C.; Annels, A.E.; Johansen, G.F.; Cuffley, B.W. General considerations of sampling and assaying in a coarse gold environment. *Trans Inst. Min. Metall. (Section B) [App. Earth Sci.]*, 2000, 109, 145–167.
- Dominy, S.C.; Petersen, J.S. Sampling coarse gold-bearing mineralisation–developing effective protocols and a case study from the Nalunaq mine, Southern Greenland. In *Proceedings of the World Conference on Sampling and Blending*, Sunshine Coast, Australia, 10–12 May 2005; Australasian Institute of Mining and Metallurgy: Melbourne, Australia, 2005; pp. 151–165.
- Dominy, S.C.; Platten, I.M. Clustering of gold particles and implications for sampling. *Appl. Earth Sci.* 2007, 116, 130–142.
- Dominy, S.C.; Xie, Y.; Platten, I.M. Gold particle characteristics in vein deposits: implications for evaluation and metallurgy. In *Proceedings of the Narrow Vein Mining Conference*, Ballarat, Australia, 14–15 October 2008; Australasian Institute of Mining and Metallurgy: Melbourne, Australia, pp. 91–104.
- Dominy, S.C.; Platten, I.M.; Howard, L.E.; Xie, Y.; Bell, R.F.; Minnitt, R.C.A. Determination of the sampling liberation diameter in a high-grade coarse gold ore by high-resolution X-ray computed tomography. In *Proceedings of the Sampling Conference*, Perth, Australia, 21–22 August 2012; Australasian Institute of Mining and Metallurgy: Melbourne, Australia, 2012; pp. 161–169.
- Dominy, S.C.; Xie, Y. Optimising sampling protocols via the heterogeneity test: challenges in coarse gold. *Mining Tech.* 2016, 125, <https://doi.org/10.1179/1743286315Y.0000000011>
- Dominy, S.C.; Glass, H.J.; Lam, C.K.; O'Connor, L.; Purevgerel, S.; Minnitt, R.C.A. 2018a. Integrating the Theory of Sampling into underground grade control strategies. *Minerals*, 2018, 8, 232, <https://doi.org/10.3390/min8060232>.
- Dominy, S.C.; O'Connor, L.; Glass, H.J.; Purevgerel, S.; Xie, Y. 2018b. Towards representative metallurgical sampling and gold recovery testwork programmes. *Minerals*, 2018, 8, 193, <https://doi.org/10.3390/min8050193>.
- Dominy, S.C.; Graham, J.C. Beatons Creek gold project, Nullagine, WA: grade control programme. Unpublished internal report, Novo Resources Corporation, 29 November 2020, pp. 183.
- Dominy, S.C.; Purevgerel, S.; Esbensen, K.H. Quality and sampling error quantification for gold mineral resource estimation. *Spectroscopy Europe*, 2020, 32(6), 21–27.
- Dominy, S.C.; Graham, J.C. Beatons Creek gold project grade control programme – Stage 1 sensitivity and optimisation: analysis and recommendations. Unpublished internal report, Novo Resources Corporation, 2 November 2021, pp. 120.
- Dominy, S.C.; Platten, I.M.; Glass, H.J.; Purevgerel, S.; Cuffley, B.W. Determination of Gold Particle Characteristics for Sampling Protocol Optimisation. *Minerals*, 2021, 11, 1109. <https://doi.org/10.3390/min11101109>
- Dominy, S.C.; Glass, H.J.; Purevgerel, S. Sampling for resource evaluation and grade control in an underground gold operation: a case of compromise. *TOS forum*, 2022, 11, 375–396. <https://doi.org/10.1255/tosf.165>
- Dominy, S.C.; van Roij, A.; Graham, J.C. Sampling of high-nugget conglomerates from the Western Australian Pilbara: Bulk sampling at the Beatons Creek gold project, Nullagine. *TOS forum*, 2022, 11, 255–277. <https://doi.org/10.1255/tosf.155>
- Dominy, S.C.; Graham, J.C.; Ison, J.; McAuslane, R. Mineral Resource update: Beatons Creek gold project, Nullagine, Western Australia. NI 43–101 Technical Report, Novo Resources Corporation, 30 June 2022, pp. 210.
- Dominy, S.C.; Parker, B.; van Roij, A.; Graham, J.C.; Glass, H.J.; Purevgerel, P. Geometallurgical testwork protocol for coarse gold mineralisation utilising PhotonAssay™. Presented at the IOM3 Geometallurgy Conference 2023, London, December 2023.
- DS3077. Representative Sampling – Horizontal Standard. 2.ed. Danish Standards Foundation, Copenhagen, 2013, 41 p.
- DS3077. Representative Sampling – Horizontal Standard. 3.ed. Danish Standards Foundation, Copenhagen, 2023 (in prep)

- Esbensen, K.H. Introduction to the Theory and Practice of Sampling; IM Publications: Chichester, United Kingdom, 2020; p. 328.
- Esbensen, K.H.; Minkinen, P.; Holmes, R.J.; Dominy, S.C.; Vogel, D.A.; Romanach, R.J.; Robben, C.; Dehaine, D.; Paoletti, C.; Engstrom, K.; et al. Economic arguments for representative sampling. *Spectroscopy Europe*, 2021, 33(7), 1–88. <https://doi.org/10.1255/sew.2021.a30>.
- Esbensen, K.H.; Wagner, C. Representative mass reduction in the laboratory: riffle splitting galore (with or without errors). *Spectroscopy Europe*, 2017, 29(1), 20–26.
- François-Bongarçon, D.M. Extensions to the demonstration of Gy's formula. *Explor. Min. Geol.* 1998, 7, 149–154.
- François-Bongarçon, D.M. Theory of sampling and geostatistics: An intimate link. *Chemom. Intell. Lab. Syst.* 2004, 74, 143–148.
- François-Bongarçon, D.M.; Gy, P.M. The most common error in applying Gy's formula in the theory of mineral sampling and the history of the Liberation factor. *J. South. Afr. Inst. Min. Metall.* 2002, 102, 475–479.
- Gy, P.M. *Sampling of Particulate Materials: Theory and Practice*; Elsevier: Amsterdam, The Netherlands, 1982; p. 431.
- Howard, L.E.; Elangovan, P.; Abel, R. L.; Dominy, S.C.; Armstrong, R. Characterisation of gold ores by X-ray micro-computer tomography part 1: software for calibration and quantification of mineralogical phases. In *Proceedings International Geometallurgy Conference, Brisbane, Australia, 5–7 September 2011*; Australasian Institute of Mining and Metallurgy: Melbourne, Australia, pp. 321–330.
- Huffman, E.L.; Clark, J.R.; Yeager, J.R. Gold analysis – Fire assaying and alternative methods. *Exploration and Mining Geology*, 1999, 7, 155–160.
- Johansen, G.F.; Dominy, S.C. Development of sampling protocols at the Bendigo gold project, Australia. In *Proceedings of the World Conference on Sampling and Blending, Sunshine Coast, Australia, 10–12 May 2005*; Australasian Institute of Mining and Metallurgy: Melbourne, Australia, 2005; pp. 175–183.
- Kyle, J.R.; Ketcham, R.A. Application of high-resolution X-ray computed tomography to mineral deposit origin, evaluation and processing. *Ore Geol. Rev.*, 2015, 65, 821–839.
- Lyman, G.J. *Theory and Practice of Particulate Sampling – an engineering approach. Materials Sampling and Consulting: Southport, Australia, 2019*; p. 540.
- Lyman, G.J. Statistical theory for sampling of particulate materials. *Minerals*, 2023, 13, 905. <https://doi.org/10.3390/min13070905>
- Lyman, G.J.; Bourgeois, F.S. Sampling, corporate governance and risk analysis. In *We are Metallurgists not Magicians: Landmark Papers by Practicing Metallurgists*; The Australasian Institute of Mining and Metallurgy: Melbourne, Australia, 2017; pp. 349–354.
- Lyman, G.J.; Robertson, I.G.; Day, T. The simple facts about sampling gold ores. In *Proceedings of the Mill Operators Conference, Perth, Australia, 10–12 October 2016*; Australasian Institute of Mining and Metallurgy: Melbourne, Australia, 2016; pp. 159–172.
- Minnitt, R.C.A. Sampling: The impact on costs and decision making. *J. South. Afr. Inst. Min. Metall.* 2007, 107, 451–462.
- Minnitt, R.C.A. The Grouping and Segregation error in the rice experiment. *Minerals*, 2022, 12, 335, <https://doi.org/10.3390/min12030335>
- Minnitt, R.C.A.; Rice, P.; Spangenberg, C. Experimental calibration of sampling parameters K and alpha for Gy's formula by the sampling tree method. *J. S. Afr. Inst. Min. Metall.* 2007, 107, 513–518.
- Minnitt, R.C.A.; Assibey-Bonsu, W. A comparison between the duplicate series method and the heterogeneity test as methods for calculating Gy's sampling constants, K and alpha. In *Proceedings of the World Conference on Sampling and Blending, Cape Town. Southern African Institute of Mining and Metallurgy. 2009*, pp. 137–154.
- Minnitt, R.C.A.; François-Bongarçon, D.M.; Pitard, F.F. Segregation Free Analysis for calibrating the constants K and  $\alpha$  for use in Gy's formula. In *Proceedings of the World Conference on Sampling and Blending, Santiago, Chile, 25–28 October 2011*; GECA-MIN: Santiago, Chile, 2011; pp. 133–150.

- Minnitt, R.C.A.; Dominy, S.C.; Esbensen, K.H. Mixing is a double-edged sword: the grouping and segregation error on the assayer's bench. *Spectroscopy Europe*, 2022, 34(1), 30–39.
- OREAS, 2023a. Au PhotonAssay™ Recertification, news release dated 4th July 2023 from Ore Research & Exploration Pty Ltd, Australia.
- OREAS, 2023b. Justification and impact of PhotonAssay™ recertification of 15 OREAS CRMs. Technical note from Ore Research & Exploration Pty Ltd dated 9th August 2023. pp. 4.
- Petersen, L.; Dahl, C.; Esbensen, K.H. Representative mass reduction in sampling – A critical survey of techniques and hardware. *Chemom. Intell. Lab. Syst.*, 2004, 74, 95–114.
- Pitard, F.F. The in-situ nugget effect: A major component of the random term of a variogram. In *Proceedings of the World Conference on Sampling and Blending*, Porto Alegre, Brazil, 23–25 October 2007; Fundacao Luiz Englert: Porto Alegre, Brazil, 2007; pp. 91–110.
- Pitard, F.F. Guidelines for acceptable allotted sampling uncertainty. In *Proceedings of the World Conference on Sampling and Blending*; Santiago, Chile, 10–12 July 2013; Gecamin, Santiago, Chile, 2013, pp. 89–98.
- Pitard, F.F. The advantages and pitfalls of conventional heterogeneity tests and a suggested alternative. *TOS forum*, 2015, 5, 13–18.
- Pitard, F.F. From errors to uncertainty – a clarification for proper use by the Theory of Sampling. In *Proceedings of the World Conference on Sampling and Blending*, Perth, Australia, 9–1 May 2017; Australasian Institute of Mining and Metallurgy: Melbourne, Australia, 2017; pp. 355–358.
- Pitard, F.F. *Theory of Sampling and Sampling Practice*; CRC Press: Boca Raton, FL, USA, 2019; p. 694.
- Pitard, F. F.; Lyman, G.J. Single and multi-stage Poisson processes: a case study for gold exploration, *Proceedings of World Conference on Sampling and Blending*, Santiago: Gecamin, 2013, 371–385.
- Prado, G.C.; Chierigati, A.C.; Pitard, F.F.; Dominy, S.C. An automated alternative for heterogeneity testing. *Minerals*, 2024, in review.
- Royle, A.G. Splitting gold assay pulps containing coarse gold. *J. Leeds Univ. Min. Assoc.*, 1989, 89, 63–68.
- Simon, A.; Gosson, G. Considerations on quality assurance/quality control and sample security. In *Proceedings of the Sampling Conference*, Perth, Australia, 27–29 May 2008. Australasian Institute of Mining and Metallurgy, 2008, 135–140.
- Stanley, C.R.; Lawie, D. Average relative error in geochemical determinations: clarification, calculation and plea for consistency. *Explor. Mining. Geol.*, 2007, 16, 265–274.
- Stanley, C.R.; Smee, B.W. Strategies for reducing sampling errors in exploration and resource definition drilling pro-programmes for gold deposits. *Geochem. Explor. Env. Anal.* 2007, 7, 1–12.
- Tickner, J. Commercial analysis of gold ores via photonuclear activation. *IRPS Bulletin*, 2021, 34(1), 6–12.
- Tickner, J.; Ganly, B.; Lovric, B.; O'Dwyer, J. Improving the sensitivity and accuracy of gamma activation analysis for the rapid determination of gold in mineral ores. *Applied Radiation and Isotopes*, 2017, 122: 28–36.
- Tickner, J.; Preston, R.; Treasure, D. Development and operation of PhotonAssay system for rapid analysis of gold in mineral ore. In *Proceedings ALTA Conference*. 2018, pp. 11.
- Tremblay, C.D.; Tickner, J.; Treasure, D.; Oteri, A.; Wheeler, G. PhotonAssay – efficient and bulk gold analysis in the modern world. In *Proceedings of the International Mining Geology Conference*, Perth, Australia, 25–26 November 2019; Australasian Institute of Mining and Metallurgy: Melbourne, Australia, 2019; pp. 88–98.
- Tremblay, C.D.; Wheeler, G.; Oteri, A. PhotonAssay – efficient and bulk gold analysis in the modern world. In *Proceedings for the AEGC 2019 Data to Discovery Conference*. 2019, pp. 4. <https://doi.org/10.1080/22020586.2019.12073071>
- Villanova, F.L.S.P.; Heberle, A.; Chierigati, A.C. Heterogeneity tests and core logging—A final reconciliation. In *Proceedings of the World Conference on Sampling and Blending*, Perth, Australia, 9–11 May 2017; The Australasian Institute of Mining and Metallurgy: Melbourne, Australia, 2017; pp. 107–113.

## Appendix

**Tab. A1:** Definition of TOS sampling errors.

Sampling error	Acronym	Error type	Effect on sampling	Source of error	Error definition
Fundamental	FSE	Correct Sampling Error (CSE)	Random Errors - Precision Generator	Characteristics of mineralisation. Relates to Constitution and Distribution Heterogeneity	Grade heterogeneity of the broken lot. FSE does not cancel out and remains even after a sampling operation is perfect. Experience shows that the total nugget effect can be artificially high because sample weights are not optimal.
Grouping and Segregation	GSE				Error due to the combination of grouping and segregation of rock fragments in the lot. Once rock is broken, there will be segregation of particles at any scale.
Delimitation	IDE	Incorrect Sampling Error (ISE)	Systematic Errors - Bias Generator	Sampling equipment and materials handling	Incorrect shape of the volume delimiting a sample.
Extraction	IEE				Incorrect extraction of a sample. Extraction is only correct when all fragments within the delimited volume are taken into the sample.
Weighting	IWE				Collection of samples that are of comparable support. Samples should represent a consistent mass per unit.
Preparation	IPE				Issues during sample transport and storage (e.g. mix-up, damage), preparation (contamination and/or losses), and intentional (sabotage) and unintentional (careless actions and non-adherence of protocols) human error.
Analytical	TAE	Analytical		Analytical process	Errors during the assay and analytical process, including issues related to rock matrix effects, human error, and analytical machine maintenance and calibration.

**Tab. A2:** Abbreviations used in this manuscript.

TAE	Total analytical error
CP	Competent Person (e.g. JORC, PERC, etc.)
CRM	Certified reference material
CSE	Correct sampling error
IDE	Increment delimitation error
DSA	Duplicate series analysis
$d\ell / d\ell_{\text{clus}}$	Liberation diameter for sampling purposes, particle vs. clustered value
dN	Nominal particle size (95% passing / 5% retained)
IEE	Increment extraction error
ESD	Equivalent spherical diameter
FA	Fire assay (assay charge size 30 g; FA30)
FSE	Fundamental sampling error
GRAV	Gravity assay method
GSE	Grouping and segregation error
ISE	Incorrect sampling error
K	Sampling constant
LDL	Lower detection limit
LINAC	Linear accelerator
LW	LeachWELL (assay charge size 1,000 g; LW1000)
NQ/NQ2	Diamond drill core size (47.6 mm and 50.5 mm respectively)
PA	PhotonAssay™ (assay charge size 500 g; PA500)
PAAU02	PhotonAssay™ 2-cycle analysis
PAL	Pulverise and leach (assay charge size 500 g; PAL500)
IPE	Increment preparation error
$P_{80}$ , etc.	Percent passing (e.g., $P_{80}$ : 80% passing a given screen size)
QAQC	Quality assurance/quality control
QFE1	Quality fluctuation error (component #1)
QP	Qualified Person (e.g. NI 43-101)
RC	Reverse circulation (drilling)
ROM	Run-of-mine
RSD	Rotary sample divider
RSV	Relative sampling variability (same as COV: coefficient of variation)
SD	Standard deviation
SFA	Screen fire assay (assay charge size 500 g; SFA500)
SNE	Sampling nugget effect (component)
TOS	Theory of Sampling
TSE	Total sampling error
IWE	Increment weighting error
XCT	X-ray computed tomography



# DS3077: Revised 3<sup>rd</sup> edition (2024)

DOI: 10.62178/sst.001.003

## 1. History of DS3077

Since the turn of the Millennium, the Theory of Sampling (TOS) has been developed into an axiomatic system comprised by six Governing Principles (GP); eight Sampling Errors (SE) and four Sampling Unit Operations (SUO) (Esbensen, 2020). This framework has served the sampling community well, allowing easy presentation of an introductory overview of TOS' concepts and principles, sampling unit operations, sampling errors, and derived equipment demands, serving as the basis for the world's first dedicated standard on the general principles of representative sampling, DS3077 "Representative Sampling – Horizontal Standard" (1st, 2nd ed.); has been chronicled in Danish Standard (2013, forthcoming 2024). The genesis of the first two editions of DS3077 has been chronicled in (Esbensen & Julius, 2013).

The present standard was published ten years ago; thus, it was time for a revision. The resulting 3<sup>rd</sup> ed. will be launched in the spring of 2024, just in time for presentation at WCSB11.

## 2. Going ISO

DS3077 3<sup>rd</sup> ed. will be submitted as a proposal for an ISO standard spring-summer 2024, from which time ISO will start its regular routines for processing a proposal for a new standard with an international call for interested parties.

This news flash constitutes a strong call for participation in this important work. The world sampling community should be able to populate the relevant ISO committee with the most competent members regarding initiating a completely new standard. This constitutes a unique opportunity for all members of IPGSA!

## References

Danish Standard (2013). DS3077, Representative sampling–Horizontal sampling (*Represæntativ prøvtagning–Horisontal standard*) 2<sup>nd</sup> ed., 26 July 2013, Charlottenlund, DK.

Danish Standard (2024). DS3077, Representative sampling–Horizontal sampling (*Represæntativ prøvtagning–Horisontal standard*) 3<sup>rd</sup> ed., forthcoming, Charlottenlund, DK.

Esbensen, K.H., Ed. (2020). *Introduction to the Theory and Practice of Sampling*, IMPublications Open, Chichester, UK.

Esbensen, K.H. & Julius, L.P. (2013). DS3077 Horizontal– a new standard for representative sampling, Design, history, and acknowledgements, TOS forum, vol.1, pp 19–23. <https://doi.org/10.1255/tosf.7>

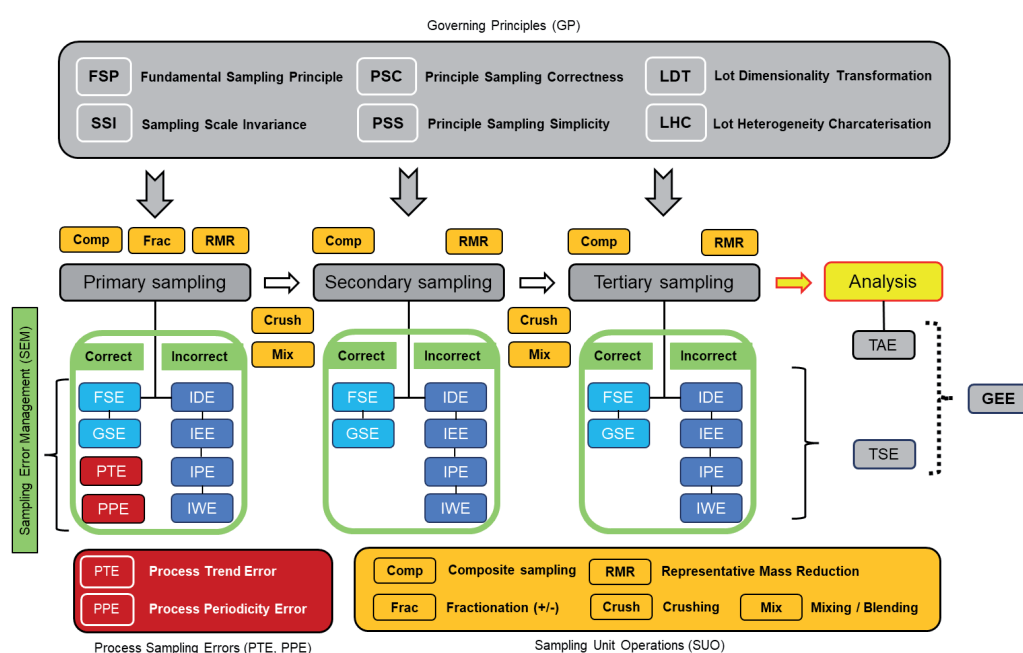

**Fig. 1:** Fully updated 3<sup>rd</sup> ed. framework, which, among other new features, includes a fifth SUO: Fractionation (+/-) and a new synoptic Sampling Error Management [SEM] element

Credit: KHEconsulting teaching collection; used with permission.

# Hidden Cost of Poor Sampling and Reconciliation Practices – Educational Lessons Far Beyond the Mining Industry

By Dominique Francois-Bongarcon<sup>1</sup> & Kim H. Esbensen<sup>2</sup>

DOI: 10.62178/sst.001.004

## 1. Five Mining Companies in Lots of Trouble

**Company A:** Take mining company A: It has produced for 18 months, but the grade is nothing near what was initially expected. There had been a complete feasibility study, on which investments were based and bank loan subscribed. The production grade predicted for the first few years made it economical to build the operation, pay costs and reimburse the loans quickly. However, now a much lower grade is produced, costs are not covered in full, loan reimbursement will be longer and much more costly, shareholders will be disgruntled. The board is very concerned of course. This is a publicly traded company and a major resource write-off on the stock exchange is in the making. A classic in the fickle mining investor world! What went wrong? Could sampling be involved?

**Company B** – needs only little introduction. It was called Bre-X and is now completely defunct. As is well known in mining and investor communities, its demise rocked the mining industry forever, and hopefully for the better. Lack of sufficient due-diligence studies, ignoring red flags, contributed to the ultimate scandal, late detection of blatant fraud and ensuing losses. Even though it is the common belief that no amount of QA, QC will ever be able to deter fraud, a fine understanding of the data, of the story they tell us, is possible when using the right tools and models – based on the right competence (TOS). After the dust had settled, the world mining industry scrambled to show governments it could self-regulate its own affairs – to avoid scandals like this.

## ABSTRACT

Behold the struggles of five fictional mining companies, the stories of which all come from real-world examples. Here are universal alarm bells of great educational significance for technical samplers and management both. We illustrate here with examples from the mining and mineral extraction world, but the implications are universal wherever professional sampling is on the agenda. Even a trivial investment in sampling training (Theory of Sampling, TOS) will be beneficial many times over. Along with honoring the founder of the Theory of Sampling (TOS), Pierre Gy (1924–2015), we highlight the important insights provided by Jan Visman (1914–2006). The presented issues do not only apply to the mining and mineral extraction/processing sectors – indeed they represent insights transgressing far beyond this demarcation.

Thus, improved routine QA, QC procedures and better resource reporting came to the fore with much more emphasis than ever before.

**Company C:** Here rumor has it the plant is not adequate for the ore mined – another classic claim, sometimes triggered by biased metallurgical tests sampling. At company C, the official metal recoveries have proven to be lower than expected and planned. Plus, ‘information’ has leaked that millions of dollars may be dumped into the tailings dam every year, as unrecoverable metal is going through the plant without being captured by appropriate sampling devices at both the mill entrance and its exit to the tailings. The announced, disappointing recoveries are in fact still over-optimistic! What happened?

**Company D:** The situation is not better at company D, where bad reconciliations between mine and plant are making everyone’s life difficult on site, as much unseen money is lost.

<sup>1</sup> Agoratek International Consultants Inc., Canada.

<sup>2</sup> KHE Consulting, Copenhagen, Denmark

## FACTBOX - The Bre-X scandal

Bre-X Minerals Ltd. was a Canadian gold exploration company, formed in 1988, that perpetrated one of the biggest scams and frauds in mining history. Commencing exploration in 1993, near the Busang river, Indonesia, with geologist Michael de Guzman as the exploration manager, Bre-X estimated the property to contain 47 million ounces of Gold (one year later even 71 million ounces) for which prospect the company's market capitalization quickly exceeded C\$6 billion. The once-penny-stock climbed to more than C\$275 per share on the global market! Who would not want to invest in such a prospect?

In 1997, a mysterious fire destroyed the on-site administration buildings including all geological records. A subsequent external audit reported only 'insignificant gold' at Busang, and the project manager Mike de Guzman died in a bizarre suicide (he "accidentally fell out of helicopter during flight"). The stock price dropped by 84% in a single day (see illustration), and the market cap disappeared. Losses were astronomical for investors.

A full investigation revealed that crushed drill core samples, the only hard evidence of high gold content (VERY HIGH) had in fact been 'salted' before they were sent for analysis. [For readers, not familiar with the evidence and information mandated for investors: "Salting: the process of adding a valuable metal, especially gold or silver, to a sample from a mine to change the value of the sample with intent to deceive investors or potential buyers of the mine" (Bre-X, Wikipedia,2023)]

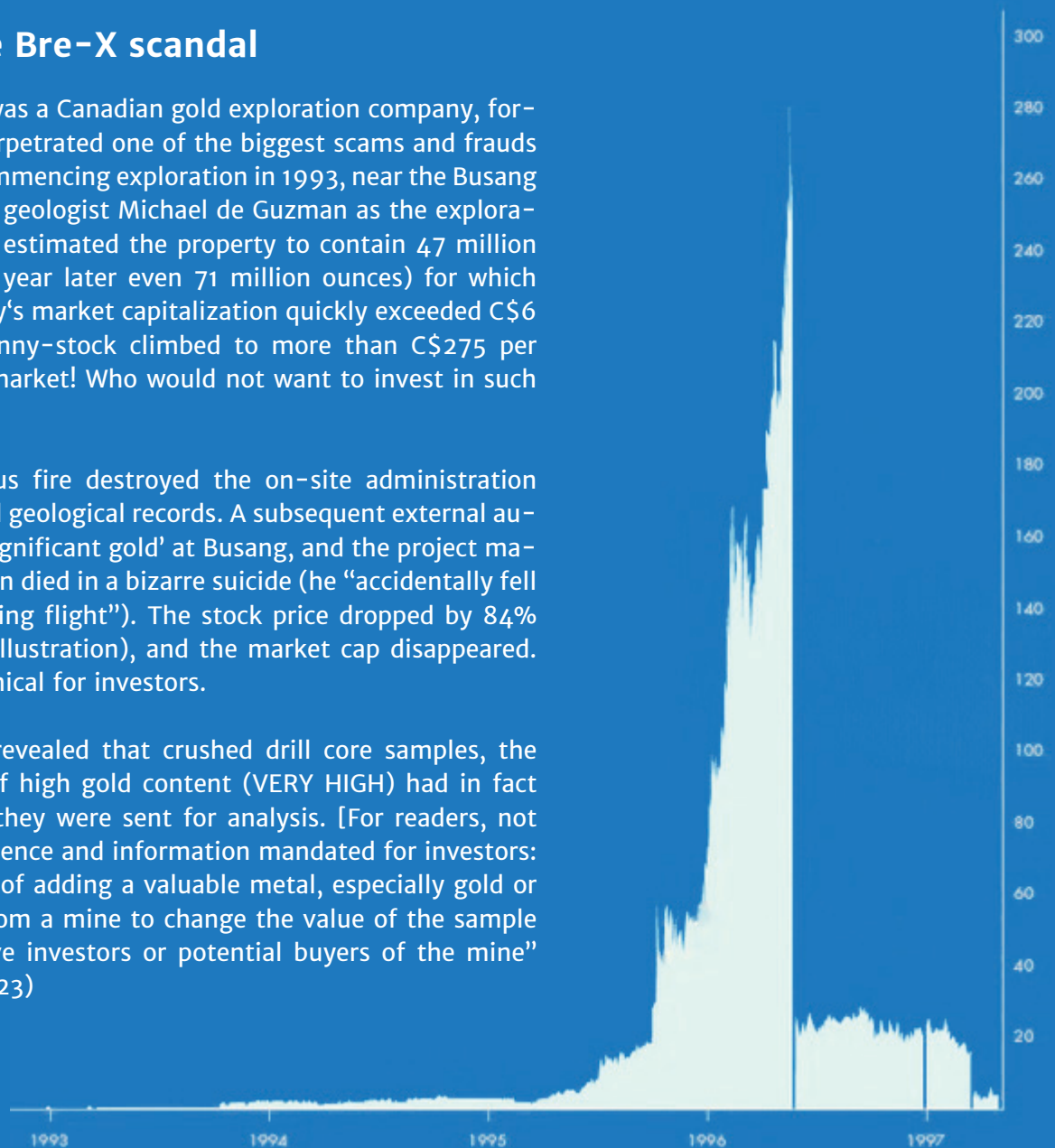

**Fig. 1:** Value: Now you see it – now you don't. Bre-X stock prices (1994-1997)

Indeed, to respond to executive pressure, the mine is scrambling for higher grades, so as a result, management orders to resort to mining outside of the original optimized mine plan. The cost of straying away from the optimal path is enormous, not to speak about the costs that future ore shortages will trigger. Why did this happen?

The redeeming grace for yet another **company E**, is that it doesn't even know it is dumping a lot of treatable ore on the waste dump.

The money it loses was never seen in any accounting scheme, so all seems to be fine! Instead, an additional problem company D is aware of, is that one of its concentrate buyers is defrauding big time with respect to the contract specifications, but company D will never be able to sue, since the sampling system in place at the loading port of departure could not survive even a cursory counter-audit, because management at company E has never understood, nor invested in professional sampling training. This last example relates to what is a typical double jeopardy ...

## 2. Double Jeopardy when the Sampling Overview is Lost

Comparison of the effect of non-matching sampling procedures (especially biased vs. unbiased procedures) for two stakeholders, generically termed “buyer” and “seller”. The consequences of non-representative sampling are serious for both parties – an unnecessarily inflated sampling variability (black) making it very difficult to be able to satisfy the contractual uncertainty interval (green). Things get completely out of control when both stakeholders, and even a third arbitration party, can freely choose sampling procedures at their own discretion. Resolution of the analytical result comparison quagmire is only possible when all parties and stakeholders agree only to use representative sampling procedures exclusively (red), no exceptions acceptable. TOS is the only necessary-and-sufficient framework in existence for this purpose. This scenario has recently been analysed and resolved in full detail in Esbensen & Vogel (2023).

## 3. What? Why?

All examples above originate from real world consulting experiences from the last 10 years. They are exclusively due to poor sampling and reconciliation practices, resulting in poor optimization of operations, which are costing tens or even sometimes hundreds of millions of dollars in unseen losses to mining companies around the world – or lead to losses that are by now well-known, but which were discovered all too late. Alas, such cases have parallel, and quite similar manifestations in many other industry sectors outside the mining realm. This malaise stems from a lack of sufficient awareness and competence of sampling theory (TOS), statistics, geostatistics, and QA, QC, QM (Quality Management), both in due-diligence and in day-to-day operational work.

## 4. Theory Of Sampling (TOS)

Yet, sampling theory, for example as taught by representatives from the International Pierre Gy Sampling Association (IPGSA), offers simple concepts (first and foremost sampling correctness and segregation countermeasures) that help analyse, understand and diagnose the kind of problems highlighted above.

As a major example, being able to implement procedures and equipment that complies with TOS' demand for “sampling correctness” will ensure sampling unbiasedness. TOS also offers numerical, very practical formulas, in particular those due to Pierre Gy, that will help quantify the magnitude of the errors responsible for many of these problems.

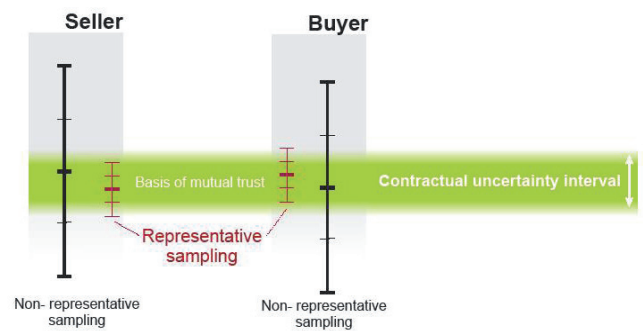

Credit: KHEconsulting teaching collection; used with permission.

**Fig. 2:** Double Jeopardy when Sampling is Unmatched at Two Parties

The value of these to the full realm of relevant industries cannot be understated.

Since 2013, there has been a de facto international standard stipulating the simple universal principles behind guaranteed representative sampling, Danish Standard (DS) 3077 (2013) and the completely revised 3rd edition, forthcoming in 2024, and soon to be made into a proposal as an ISO standard. The IPGSA community is (strongly) encouraged to participate in the latter task.

## 5. Powerful, Yet Simple Theory to the Rescue (Jan Visman)

TOS has sometimes been perceived as cryptic or esoteric to the non-mathematically oriented practitioner, yet simple formulae can be derived with which to address ordinary, as well as less standard sampling problems, in very practical ways. Such as the little known, but very powerful “Visman’s formula” concerning the relative sampling variance:

$$\text{Rel.Var.}(\text{Visman}) = A/M + B/N \quad (1)$$

Visman’s equation relates to an easy experimental approach that allows us to control a sample assembled as a collection of N random increments, the archetype composite sample, when its sampling error (sampling variance) is due not only to its mass (M) and the heterogeneity of the material (encapsulated by the term A/M), but also to segregation manifestations that cannot be eliminated (embedded in the term B/N). Simple practical experimentation is all it takes to calibrate the two constants A and B with which to gain full control over the results of sampling, even in very adverse sampling situations tormented by segregation.

To do this, Visman advocated taking two series of 1-increment samples (grab samples in the TOS parlance): one series of very small samples, and one of very large counterparts (the large difference in masses aims at stabilising the results). Equating the variances of the two series to equation (1) yields a system of two linear equations which is easily solved, allowing for determination of the two unknown constants A and B.

In other situations, for example where a full heterogeneity characterization study has been performed, one may prefer calculating the first term  $A/M$  from the heterogeneity parameters obtained, and a single series of samples is then sufficient to elicit the value of B in (1).

## 6. Adding in the Unavoidable Effects of Segregation

Gy's fundamental sampling variance formula for a correct sample when segregation is not present (very well known, and highly valued but frankly, also often misused by ill-informed practitioners) is:

$$\text{Rel.Var. (Gy)} = S_{\text{FSE}}^2 = c f g l d^3 / M \quad (2)$$

provides Visman's  $A/M$  term in the case where none of the parameters other than mass  $M$  can be changed, i.e. in the case of fixed mineralogy, concentration and comminution state.

But Gy also established the formula when segregation is present (the general, realistic real-world case):

$$\text{Total Rel.Var.(Gy)} \sim [1 + \beta/N] S_{\text{FSE}}^2 \quad (3)$$

It is not necessarily easy to appreciate that the term  $[\beta/N]S_{\text{FSE}}^2$  in turn provides Visman's  $B/N$  term under the same conditions, but here goes:

Indeed, the second term in (3) is  $[\beta/N S_{\text{FSE}}^2]$ , for which Gy showed that  $\beta \sim \xi(N_F - N) \sim \xi N_F$  where  $N_F$  is the number of fragments in the sample. As a result,  $[\beta/N S_{\text{FSE}}^2] \sim (\xi N_F/N) S_{\text{FSE}}^2$  which is of the form  $\xi N_F K/(N M) = \xi K/[N (M/N_F)]$  (as  $S_{\text{FSE}}^2$  is in inverse proportion of  $M$  for large lots). But as  $M/N_F$  is the average fragment mass in the sample,  $M$  is eliminated from the expression, which is now of the form  $B/N$ . **q.e.d.**

## JAN VISMAN

Jan Visman (2 July 1914 – 19 February 2006) was a Dutch statistician who played a key role in building a bridge between statistical sampling theory with its assumed homogeneous (iid) populations on the one hand, and practical sampling practice with well-known heterogeneous sampling units (TOS's heterogeneity contributions) and material lots on the other. Visman built an elegant theory in only a few easy-reading pages, quite independently from Pierre Gy's development of the Theory of Sampling (TOS). Upon reflection it will be appreciated that Visman's approach is but a particular, special case within TOS. Visman's formula was devised to establish the Canadian standards for the sampling of shiploads.

For the interested reader who did not find immediate comprehension relief by this compact explanation, there are more complete theoretical introductions available, e.g., Pitard (2019) and Lyman (2020).

## 7. Sampling in Practice

In all sampling procedures, there are two imperial demands that must be met before any other optimization details can be entertained;

1. The first demand on any sampling agenda is to respect the principle of *sampling correctness*, which is the only guarantee for unbiased sampling. This is the most fundamental requirement for professional samplers, e.g., as laid out by the educational systematics of TOS (Pitard, 2019; Lyman, 2019; Esbensen, 2020).
2. After this demand has been honored, there is now general flexibility over the sampling parameters, and the effects of segregation can be canceled out (see above), Gy's general formula (3) will now allow full control of the sampling precision.

In other cases where sampling parameters offer no flexibility, and additionally the usually devastating effects of segregation on sampling precision cannot easily be neutralized, case Visman's experimental approach will offer a powerful safe way out.

## NOTE TO GEOSTATISTICAL CONNOISSEURS:

Interestingly, Visman's formula also brilliantly comes to the rescue when *geostatistical* estimations are required, but when calculating experimental variograms is not an option (for example nuclear decontamination, diamond resources, etc.), or when sampling in-situ stockpiles (no way out of local segregation effects).

Because of the duality between segregation and spatial correlations, variance in eq. (1) can be equated to a 'nugget term'  $A/M$  and a 'structure' term  $B/N$ , as would the estimation variance calculated from the two components of a variogram. Thus, the simple Visman experiment as per eq. (1) therefore provides the geostatistical estimation variance *without* having to infer a variogram.

## 8. Visman on Sampling Segregated In-Situ Stockpiles

Of course, sampling can only be controlled for the immediately accessible (external) part of a stockpile. The Visman experiment must therefore be repeated as material collection progresses *into* the pile, unless one is willing to *assume* that segregation is *identical* throughout the complete inner volume of the stockpile as the one found on its external surficial parts – which would be an extremely risky endeavor.

Among other things, optimality of eq. (1) implies  $A/M = B/N$ , or  $M/N = A/B$ , which now appears as the optimal increment mass. Assuming this mass, eq. (1) then simplifies into:  $Rel.Var. = 2 B/N$ , which determines the number of increments necessary to achieve a preset precision threshold target.

Comparing the experimental first term of Visman's formula with the empirical results from a TOS heterogeneity test, or a Replication Experiment (RE) (Esbensen, 2020), can considerably improve understanding of complex, segregated mineralization cases and their corresponding optimal sampling options.

Following this line of exemplification, it is easy to see how Vismans's equation can also be used to test geological hypotheses of mineralization *randomness*, for instance in kimberlite diamond deposits.

## 9. Reconciliation – the Way Forward

The value of comprehensive reconciliation studies should never be undervalued. Usually triggered by one of the problems mentioned in the five cases in the introduction, they will throw light on the insufficiencies that may have triggered them. Indeed, one by one, every single potential cause for bad reconciliations can be examined and put to the test. The quality of sampling, assaying, and estimation procedures will be reviewed, and any flaws will be detected and eliminated.

In the case of a mining operation for instance, a Plan-to-Production reconciliation task will usually be broken down in the study into a series of individual part-reconciliations:

- Plan to mine-estimated mill feed (delivered) – often designated as F1 reconciliation
- Mine-estimated mill feed to Mill-estimated mill feed (e.g. head sampler) – F2 reconciliation
- Mill-estimated mill feed to balance (Production and reconciled figures)

These more focused tasks can inspect all issues in detail, as described above. Additional experimentation will help decide which steps may have triggered biases in the data used and thus identify the resulting erroneous decisions.

Courses on reconciliation techniques, drawing from all fields concerned, will help professionals sort out, and address the problems of sampling, data QA, QC, QM and, in the case of mining, ore grade models quality in turn. Underlying all of this is the foundation of representative sampling, at all locations, at all scales, for all kinds of ores – TOS to the fore!

All the above reflections do not only apply to the mining and mineral extraction/processing sectors – the presented educational insights transgress far beyond this demarcation.

2022 saw publication of a valuable compendium: "Economic Arguments for Representative sampling", containing a bonanza of educational examples and case histories from no less than 27 experts from all over the sampling world (Esbensen, 2021).

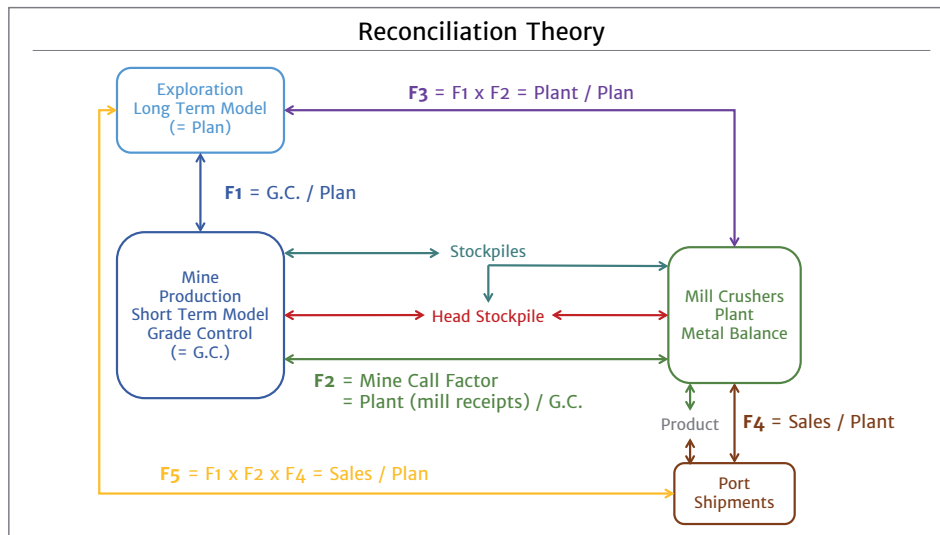

Credit: Dominique Francois-Bongartcon; used with permission.

**Fig. 3:** Overview of local stage part-reconciliations from Mine to Sales: F1, F2, F3, F4, F5

## 10. Conclusions

What are the main lessons from the present compendium of evergreen sampling problems and issues?

In the age of global competition, many industrial mineral extraction operations are only marginally profitable, even when well run, or when operations are extremely data quality sensitive, continuous professional sampling training is at a premium.

A small investment in training (TOS, statistics, geostatistics, QA, QC, QM) may save huge amounts of money downstream in many contemporary industries at all mining time scales and stages: development, operation, operation closure and reclamation.

Professionals will discover and learn that beyond what appears as deceptively complicated theories, lies a wealth of easy-to-understand, efficient techniques, which can be mastered in a short time with huge economic benefits when well used. Several convincing examples can be found in (Minkinen & Esbensen, 2018).

In 2023, the Council of the International Pierre Gy Sampling Association (IPGSA) has started a drive offering new educational training options at all levels from initiating newcomers to the sampling responsibilities – to full professional continuing education. The reader may follow this drive at the IPGSA website.

## References

- Bre-X, Wikipedia, Accessed 29 August 2023. <https://en.wikipedia.org/wiki/Bre-X>
- Danish Standard (2013). DS3077, Representative sampling—Horizontal sampling (*Repræsentativ prøvtagning—Horisontal standard*) 2<sup>nd</sup> ed., 26 July 2013, Charlottenlund, DK. [www.ds.dk](http://www.ds.dk)
- Danish Standard (2024). DS3077, Representative sampling—Horizontal sampling (*Repræsentativ prøvtagning—Horisontal standard*) 3<sup>rd</sup> ed. forthcoming, Charlottenlund, DK [www.ds.dk](http://www.ds.dk)
- Esbensen, Kim H.; Vogel, D. Aldwin (2023). The Elephant in the Room, *The Alchemist 110*, London Bullion Market Association, London, UK., July. <https://www.lbma.org.uk/alchemist/alchemist-110>
- Esbensen, Kim H. (2020). *Theory and Practice of Sampling*, IMPopen, Chichester, UK.
- IPGSA (2023) International Pierre Gy Sampling Organization website. <https://intsamp.org/>
- Lyman, Geoff J. (2019). *Theory and Practice of Particulate Sampling on Engineering Approach*, Materials Sampling & Consultancy PTY, LTD., Southport, Queensland, AUS.
- Minkinen, Pentti O.; Esbensen, Kim H. (2018). TOS will save you a lot of money (pun intended), *Sampling column, Spectroscopy Europe*, 30(2) Chichester, UK., pp. 16–20. <https://www.spectroscopyeurope.com/sampling/following-tos-will-save-you-lot-money-pun-intended>
- Pitard, Francis F. (2019). *Theory of Sampling and Sampling Practice* 3<sup>rd</sup> ed., CRC Press, Taylor & Francis Group, Boca Raton, FL., USA
- Esbensen, K.H. (Ed.). (2021.) 'Economic arguments for representative sampling in technology, industry, commerce, trade and society,' from special issue of *Spectroscopy Europe*, 33(1), Chichester, UK. <https://www.spectroscopyeurope.com/sampling/economic-arguments-representative-sampling>.

# International Pierre Gy Sampling Association: A New Beginning

By Claudia Paoletti<sup>1</sup>

DOI: 10.62178/sst.001.005

## 1. Background

The founding of the Theory of Sampling (TOS) by Dr. Pierre Gy in the 1950's marked the start of a new era for key industrial sectors where sampling is applied to help taking informed decisions. Initially, Gy's ground-breaking work was mainly valued in the economic-geology sector (mining, exploration, mineral processing, metals, cement), where his nine books and hundreds of publications provided a completely new framework to start solving salient sampling issues and addressing the adverse effects caused by heterogeneity. Only fifty years later, around the turn of the millennium, the wider relevance and applicability of TOS across a broad range of societal sectors, disciplines, and domains where sampling is important for decision-making processes, came to the fore.

In 2003 the first World Conference on Sampling and Blending (WCSB1) was organised in Esbjerg, Denmark to honour Dr. Gy, to facilitate fruitful discussions surrounding TOS, and to exchange scientific and technological views around representative sampling practices. Time proved that WCSB1 was the start of an enduring success story that continues up until today with the biannual organization of the WCSB series around the globe, now preparing for its 11th edition. The last two decades have witnessed the continuous growing of TOS-applications within the traditional mainstream arenas, and a deliberate increasing drive to extend TOS-application beyond this boundary. This triggered a constructive, lively and spontaneous forum, developed largely without much organisational support other than the biannual WCSBs.

Finally, 2017 marked the official establishment of the *International Pierre Gy Sampling Association* (IPGSA), driven by two noble motivations: 1) to promote development and application of the Theory of Sampling (TOS) across all relevant scientific, societal, and industrial sectors; and 2) to offer science-based advice on all



matters regarding proper sampling of heterogeneous materials, lots and processes of any nature and provenance. After its establishment, the compelling enthusiasm allowed IPGSA to develop into a well-organized association ready to promote, network, discuss and share the latest advances in the theory and practice of sampling and blending, including current scientific research and relevant technological developments. But, as always, reality is more complex than foreseen. The sparking momentum that promoted IPGSA establishment partially mellowed for several reasons:

- IPGSA's founders were, for the vast majority, sampling experts who applied their experience in specific industrial sectors focusing on mining, minerals processing, cement, and metals refining. But the steadily growing inclusion of sampling professionals from other sectors imposed the sharing and incorporation of new application challenges, the understanding of 'unfamiliar' sampling issues, and the development of a new culture to elevate sampling to the level of an inclusive, recognised objective scientific discipline. If on one hand this enriched IPGSA with a plurality of views fostering scientific growth and a healthy elaboration of new ideas, on the other it partly intruded into the high-level technical and detailed discussion flow, which was the priority of a small group of samplings experts operating mainly in the geoscience and process industry arenas.

<sup>1</sup> EFSA, Parma, Italy.



- IPGSA became operational during a natural generational turnover. The founding fathers of IPGSA were experts who grew up scientifically and technologically as Gy's fellows and, students starting their sampling careers under his supervision. But in the run of the first two decades of the 2000's, IPGSA witnessed the arrival of a next generation of sampling professionals, with partly novel ideas and distinctly novel challenges. Accepting change is always difficult, but passing the baton to a new generation requires an incredibly open state of mind, which may be difficult to reach after the experience cumulated over a successful life-time career.
- IPGSA welcomed and housed sampling experts from different schools: those who started their career understanding the practical benefits of Gy's theoretical work and built on this knowledge to ensure TOS' continuous evolution, and a few others belonging to schools other than that of Gy's, who did not necessarily agree with all his work. Nurturing an environment in which a range of perspectives are brought forward respectfully, allows growing towards deeper understanding of the scientific basis of the joint work pursued. It would be in the interest of the continuous evolution of the science of sampling, to enhance and facilitate fruitful exchange between opposing theoretical advocates. Unfortunately, this was not always the case, and occasionally personal controversies surfaced and to some degree influenced the joint forum.

However, the above did not stop IPGSA's success story. On the contrary! It helped IPGSA to become a mature scientific association, capable to evolve and spearhead its transformational change to launch a series of new initiatives and go through a virtual new beginning. Here I wish to present the highlights of this new beginning, illustrating the renewed societal vision and the work-plan for the next few years. Building upon 20+ years of experience, IPGSA is now ready to help raising sampling science and technology to the next level of a comprehensive and fully recognized scientific discipline.

## 2. Vision, Structure & Objectives

In line with the motivating values that formed its establishment in 2017, IPGSA pinpointed its vision as '*becoming the internationally recognised scientific organisation guiding and advising on all matters regarding sampling of heterogeneous materials, lots, and processes across all relevant scientific, societal and industrial sectors.*'

At onset, IPGSA focused on establishing its organisational rules, principles and governance. The association is headed by a Council who prepared and adopted IPGSA constitution where mission, membership roles and responsibilities, organizational structure and financial arrangements are detailed. The Council also manages IPGSA routine activities.

Shortly after, 2019 and 2021 witnessed a significant slowing of IPGSA activities, mainly because the Covid pandemic changed worldwide the way colleagues could interact and collaborate, forcing all work settings to learn a new way of working together. Unfortunately, the effect of the pandemic hit IPGSA simultaneously with the delicate consolidation of a natural generational turnover: the impossibility to meet in person did not help the speed with which the necessary understanding, trust and confidence between the old and new generation of sampling-experts could be established to smoothly refurbish IPGSA leadership. But the strong will to ensure the future of the association allowed to unravel all glitches and to progress shaping a new outlook and workplan.

Rebooted by this energy, in 2022 IPGSA Council defined three key macro-objectives on which to focus expert-investment and to build its re-framed work-programme:

1. **Know-how development:** to guide and lead the developments of TOS, from both theoretical and practical perspectives, across all sectors in need of sampling to take informed/optimal decisions.
2. **Advice and support:** to provide assistance on sampling matters across all sectors to any end-users relying on sampling to make inferences in commercial, industrial, academic, research and regulatory activities.
3. **Capability building:** to offer, or help to offer, competence building (training lectures and didactic material) to actively communicate and demonstrate TOS and its applications on a broad front, securing the continuous expertise-transfer necessary for the spread and perpetuation of correct sampling practices.

The most important IPGSA responsibility, supporting all three macro-objectives, was – and continuous to be – the organization and supervision of the World Conference on Sampling and Blending (WCSB) every two years. After the inaugural WCSB1 in Denmark, WCSBs moved around the globe covering all relevant continents, regions and important industrial sectors: 2005 Australia, 2007 Brasil, 2009 South Africa, 2011 Chile, 2013 Perù, 2015 France, 2017 Australia, 2019 China, 2022 Norway. The next world conference, in 2024, will be in South Africa.

Over the past two decades, the WCSB series established itself as an inclusive authoritative forum where a wide range of topics within the realm of applied TOS, as well as several theoretical overviews and new developments are presented and discussed, serving as a unique and enriching educational platform. Over the years attendance has grown steadily: scientists, consultants, technicians, industry, and regulatory bodies representatives actively participate, establishing stimulating interactions and collaborations. The accumulated archives of the WCSBs' proceedings are a solid and well-recognised source of key papers and technical documents providing in-depth information on sampling and TOS.

But there are two sides to this issue: If WCSB series is a success story ranking at the top of IPGSA priorities, the time between conferences, characterised by an almost complete lack of activities, has been a worrisome reality for the Council, even after the successful WCSB10 in Norway managed to re-inspire the international sampling community. With a strong wish to fix the situation and the awareness that a new beginning is always possible, IPGSA's newly elected Council (2022) decided to re-think its way of working, to develop an association work-programme and to establish a strategy for its implementation. In 2023, to secure continuity of initiatives over time, IPGSA launched *ad hoc* operational Working Groups (WGs) coordinated by WG Leaders, normally members of the Council, responsible to set clear and sustainable goals supporting the achievement of the three macro-objectives. These WGs are operational throughout the year and report quarterly to IPGSA Council.

Currently there are five WGs:

1. WG1 – Scientific platform: to ensure a scientific platform for all those interested in the theory and practice of representative sampling and blending, and especially to disseminate awareness of proper sampling practices to other interested parties in science, technology, industry and society at large.

From 2013 until today, the *TOS forum*, a free publication at the service of the sampling community as well as the enduring educational *SAMPLING* column in the magazine *Spectroscopy Europe/World*, both edited by Prof. Kim H. Esbensen, have outstandingly served the purpose. Today *TOS forum* and the *SAMPLING* column pass the baton to *Sampling Science and Technology* (SST). Although the reasons for this change are sad as explained by Prof. Esbensen elsewhere in this inaugural issue, on behalf of IPGSA community, I wish SST the best of luck to continue growing and admirably serving the scientific sampling community, which will be continued under the solid editorial experience of Prof. Esbensen. Thanks Kim!

2. WG2 – Communication platform: to refurbish and maintain up to date the IPGSA webpage, offering a digital platform where key papers, technical documents, active links, blogs and library sections are available to provide in-depth information on sampling & TOS. The webpage will be re-structured in a multi-tiered fashion to address the needs of all stakeholders, regardless of their level of sampling experience, may they be beginners or experts. IPGSA is also on LinkedIn to facilitate connecting sampling professionals, networking, exchanges and reaching out. This work is currently on-going and we hope to meet you soon on LinkedIn or host you on IPGSA new webpage.
3. WG3 – Technical training: to ensure competence building and knowledge transfer, IPGSA shall offer lectures, structured courses and training materials to private and public organizations, academia, research organizations and governmental bodies. With several decades of training experience, IPGSA can calibrate on costumers' needs and offers educational excellence at all levels from building TOS know-how, to addressing specific and unique complex sampling issues, to establishing the background knowledge necessary to appreciate the relevance of sampling in different frameworks; this will be cared for in close collaboration with SST. Through IPGSA webpage and LinkedIn IPGSA will make training material available to all interested parties.
4. WG4 – Stakeholder Management: to start engaging with stakeholders, IPGSA adopted a stepwise approach starting from identifying stakeholders and analysing their needs and expectations, to planning and implementing targeted initiatives and tasks.

IPGSA wishes to consolidate an open dialog with key international regulatory bodies (e.g. IMO, ISO) and key players involved in circular economy who require sampling solutions for new material streams. The already existing collaboration with academia and research institutions needs to grow further and expand as the synergy with the agricultural, food, feed, pharmaceutical sectors must consolidate to recover the delay cumulated when TOS was prerogative of the geo-sciences.

5. WG5 - Budget: to manage IPGSA financial resources and secure future fundings. IPGSA has currently no permanent source of income and its limited resources come from WCSBs fees. Despite the unlimited good will of IPGSA members, who devote time and energies to the many initiatives of the IPGSA work-programme, the association needs a secure annual minimum budget to ensure its functioning and coverage of active costs. The search for funding opportunities is pressing and continuous. The establishment of a dedicated WG hopefully will facilitate effective brainstorming for fund raising.

### 3. Concluding remarks

If we think about the volume of decisions taken across all sectors worldwide that would have needed correct sampling to be properly informed, we get frightened imagining the high price the world is paying for failing to ensure correct sampling practices across all affected sectors. Historically sampling remained the priority of small, highly technical scientific-lounges and was never elevated to the level of a recognised objective scientific discipline, co-equal with e.g. engineering, statistics, data analysis. The goal of sampling is to allow making reliable inferences from limited samples and analytical data. If their representativity is not documented, all following inferences are based on *nothing* but 'specimens' not worth analysing. This simple universally true fact is the reason why sampling deserves to be taught systematically in most world's universities.

Since its start, IPGSA wanted to open and promote a constructive dialog across sampling experts to establish the Theory of Sampling as a discipline that warrants global recognition, understanding and interpretation. It succeeded in the economically most important mining, minerals and metals sectors, although even here IPGSA occasionally faced inertia and resistance when trying to explain the benefits offered by TOS: communities and individuals are comfortable and familiar with existing routine sampling procedures, and do not see obvious advantages in changing a beloved *status quo*.

This situation is much worse in other sectors such as agricultural and environmental sciences, food and feed safety, pharmaceuticals, ecological sustainability where a culture valuing correct sampling practices is starting to develop lately. I believe many years are still needed before the merit of sampling is fully recognised.

After Covid, to remain relevant, IPGSA had to decide how to invest in the future. Two options: a) focus on TOS' own community and TOS developments without broadening outreach investment; b) raise sampling to the level of a comprehensive scientific discipline and work hard for getting full recognition. The 2022 renewed IPGSA Council chose the latter way, and the new beginning summarised here is the first step of this collective journey.

The three ambitious macro-objectives *know-how development, advice and support and capability building* will frame the milestones IPGSA wishes to reach in the next five years, namely:

- Establish, and keep a constructive dialogue among all sampling experts, as a plurality of views is essential for scientific growth and elaboration of innovative ideas.
- Collaborate with/support other international organizations to develop/revise/update relevant standards and guiding documents in all sectors where sampling is needed, explicitly or implicitly.
- Invest in education and training. IPGSA makes available its experience to everybody interested, especially encouraging universities, technical academies to get in touch to explore collaborations.

The new IPGSA vision and workplan are very ambitious and resources are very limited. But motivation is high. The future of sampling depends on what we do today, and we are all accountable towards the future generations. IPGSA is well aware of this responsibility and has decided to follow the advice of a wise man: *Be the change you wish to see in the world* (Mahatma Gandhi).

### DISCLAIMER

Claudia Paoletti is employed by the European Food Safety Authority (EFSA). The position and opinion presented in this article are those of the author and do not necessarily represent the views or scientific works of EFSA. The author declares that she has no conflict of interest.

# If Mahomet Won't Come to the Mountain, the Mountain Must Come to Mahomet: Transforming Sampling and Preparation Services for Circular Economy Materials through a Specialised TOS Compliant Mechanical Sampling Hub

By Duncan Aldwin Vogel<sup>1</sup>

DOI: 10.62178/sst.001.006

## 1. Introduction

This paper demonstrates the transformative potential of a specialised mechanical sampling hub concept for offering the highest accuracy, precision, and robustness of sampling and sample preparation services in the realm of circular economy materials, with a specific focus on Incinerator Bottom Ash (IBA). Capitalizing on the Theory of Sampling (TOS), Alfred H Knight (AHK) has inaugurated a cutting-edge sampling hub in the Netherlands. This innovation confers significant economic, operational, and trust advantages to a broad spectrum of stakeholders, including IBA suppliers and copper smelters. By reversing the traditional third-party inspection model, i.e., by transporting the material to a specialized facility instead of sending an inspector to the site, the sampling hub approach secures reliable representativity by eliminating incorrect sampling errors, while reducing correct sampling errors to acceptable levels for the parties of the trade. This revolutionary, independent third-party sampling hub approach not only speeds up payment cycles and reduces the technical risk of being wrong, but also minimizes the environmental impact of material transportation and metal production relative to virgin metal production, thus aligning with UN World Development Goals numbers 9 and 12.

## ABSTRACT

Incinerator Bottom Ash (IBA) is a by-product formed at the base of waste incineration furnaces during the combustion of waste materials, e.g. municipal solid waste. Comprised primarily of metal, glass, and mineral species, the Heavy Non-Ferrous fraction of IBA (HNF) is especially rich in valuable metal concentrations of copper, gold, silver, platinum, and palladium. Serving as an optimal feedstock for metal smelters, this IBA fraction presents distinct environmental advantages as secondary, circular metals requires fewer production steps and reduced energy consumption compared to their virgin counterparts derived from natural ore and mineral concentrates. Because of its intrinsic high value, accurate and representative sampling and testing of IBA is essential for equitable commercial transactions. The highly heterogeneous nature of IBA presents complex sampling, testing, and analysis challenges, which require strict adherence to sampling approaches in complete compliance with the Theory of Sampling (TOS).

This paper outlines the technical foundations of the mechanical sampling system that has been established and implemented by AHK in the Netherlands. This new approach introduces the innovative sample preparation technique of homogenization through melting of a large bulk sample of IBA, elucidates the associated quality control mechanisms to establish system robustness, and highlights its many multi-stakeholder advantages. In doing so, it hopes to lay a compelling case for broader adoption of this approach in the global circular economy industry elsewhere in the world and for other metal recovery products as well, all contributing to responsible and sustainable sourcing of critical metals for electrification and battery technologies.

<sup>1</sup> Alfred H Knight Holland B.V.

## 2. Urban Mining

Municipal Solid Waste (MSW) is mainly comprised by household refuse or similar waste appropriate for incineration. The incineration process converts waste to energy through combustion. Incineration Bottom Ash (IBA) is the primary solid byproduct of this process, accounting for approximately 80% of all incineration residues by weight (Chimenos et al., 1999). The global production of IBA is substantial, particularly in Europe (Dou et al., 2017; CEWEP, 2023). For each tonne of MSW incinerated, approximately 150–250 kg of IBA is produced (Hyks and Hjelmar, 2018). In 2021, there are over 800 waste incinerators worldwide and over 400 in Europe. MSW incineration plants in the European Union process around 62 million tonnes of MSW annually, yielding about 12 million tonnes of untreated IBA, which represents 26% of the annual incinerated waste by mass (Eurostat, 2023).

Municipal Solid Waste Incineration (MSWI) serves not only to harness the energy content of waste, but increasingly also facilitates the recovery of various valuable components. This makes MSWI an integral component of the circular economy (Van Caneghem et al., 2019; Pan et al., 2015; Malinauskaite et al., 2017). The composition of untreated IBA varies according to the MSW feedstock, combustion technology, and operational conditions at the incineration facilities. IBA is a highly heterogeneous material primarily comprised by complex inorganic mixtures of melted products, minerals, metallic compounds, ceramics, and glass. Specifically, the mineral fraction constitutes 80–85% of the bulk mass of untreated IBA, while the remaining 10–12% is made up of combined ferrous (Fe) and non-ferrous (NF) metals.

Specifically, attention will here be centered on the fraction consisting of heavy and non-ferrous metals, designated as the Incinerator Bottom Ash Heavy Non-Ferrous Metals Fraction (IBA-HNF). Serving as an alternative feedstock for copper smelters and precious metals refining plants, IBA-HNF can substitute for mineral concentrates and even eliminate certain production steps otherwise necessary for generating virgin metal from mining resources. Recovery rates stand at approximately 90% for copper, 70% for silver, and 80% for gold contained in untreated IBA. Beyond the direct energy efficiencies in the production process, there are also substantial transport-related savings, especially pertinent when considering that copper ores are primarily sourced and concentrated in distant regions or countries beyond, for example, Europe.

## 3. Sampling Hub The Netherlands

The growing understanding of the value and potential associated with the product, IBA-HNF, clearly highlights the need for precise quantification and qualification. This is essential for transferring ownership and settling financial transactions. Multiple stakeholders participate in the process from Municipal Solid Waste Incineration to the smelting and refining of metals such as copper, gold, silver, platinum, and palladium. Like traditional commodities, IBA-HNF is bought and sold based on its verified mass and elemental composition—copper, gold, silver, platinum, and palladium—determined through critical sampling and analysis.

To ensure commercial settlements between IBA-HNF producers and receiving copper smelters are accurate, this circular economy industry needs representative samples. However, the representativeness of an individual sample is not discernible from the sample's own characteristics. Instead, the focus must be on specifying the qualities a sampling process must have to be considered representative. According to TOS, a representative sample results from a representative sampling process. Therefore, a sample is either representative or not; an unrepresentative process can only produce 'specimens' with an unknown provenance, making them unsuitable and unreliable for analysis and crucial decision-making in various sectors.

For a sampling process to be qualified as representative, active steps must be taken to eliminate or minimize both bias and precision. While most sampling standards and their respective sections focus primarily on procedures to minimize total effective precision, it is crucial that efforts to eliminate sampling process bias are not overlooked (DS3077, 2013; Esbensen, 2020; Pirtard, 2019; Lyman 2020). In fact, guidelines often emphasize the importance of eliminating bias, but often lack specific procedures to accomplish this task. Failure to comply with these essential steps, whether intentionally or inadvertently, constitutes a breach of due diligence in designing, preparing for, and executing a documentable, representative sampling process.

This sets the stage for the introduction of the solution for weighing, sampling, sample preparation, and testing that Alfred H. Knight has developed for IBA-HNF in the Netherlands; this is termed the Sampling Hub.

#### 4. If Mahomet Won't Come to the Mountain, the Mountain Must Come to Mahomet

Focusing first on the relationship with the elimination of sampling process bias, it is important to emphasize the persistent heterogeneity in Municipal Solid Waste (MSW) and the resulting untreated Incineration Bottom Ash (IBA).



**Fig. 1:** Typical heterogeneity manifestation of a 25-tonne lot shipment of IBA-HNF. Note how larger particles accumulate at the bottom and smaller particles remain at the top due to segregation during stockpile build-up.

This heterogeneity remains largely unmitigated even after minerals and metals have been separated and concentrated in IBA-HNF. Typically, individual traded shipments are around 25 tonnes, but it is important to note that these smaller tonnage shipments are actually composites, blending IBA-HNF streams originating from different concentration and beneficiation stages and from different Municipal Solid Waste Incinerators (MSWI) across Europe. There is thus no 'typical' IBA-HNF material.

Although IBA-HNF constitutes only 1-4% of untreated IBA by mass, this concentrated product on closer examination reveals phenomena such as grouping, segregation, and nugget effects, which are common in stockpiles of solid bulk particulate materials. The nominal top size of IBA-HNF is 19 mm, and with a moisture content of less than 3%, the material is mostly free-flowing. However, the presence of non-ferrous metals from cables and wires may cause material aggregation, much like yarn forming a ball. Furthermore, during stockpiling operations, larger particles tend to concentrate at the bottom and smaller particles rise to the top (Figure 1).



**Fig. 2:** Close-up photo depicting free gold particle from IBA-HNF material attesting to highly significant heterogeneity at particular scales.

Considering the variations in the composition of distinct particle sizes and the evident nugget effect in cases like gold particles (Figure 2), it becomes clear that manual sampling of a three-dimensional lot (3D) will fail to meet the core principle of The Theory of Sampling (Gy, 1979). Specifically, this framework advocates that “For precision and accuracy, it is essential that increments (or cuts) are extracted in such a way that all particles from the lot have the same probability of being selected and becoming part of the final sample for testing, irrespective of their shape, size, mass or density.”

Previously, sampling of IBA-HNF shipments for copper smelters and refiners in Europe was carried out using the following traditional techniques:

1. Utilization of an excavator or wheel loader for mechanical *quartering-and-coning* of the entire 25-tonne lot, followed by the extraction of a primary sample using a bucket excavator. A sub-sample was then acquired through *manual shoveling* for further preparation and analysis.
2. Mechanical increment sampling was executed by driving a shovel attached to a wheel loader into various positions around the circumference of the 25-tonne 3D stockpile. The sample mass was subsequently reduced via mechanical *quartering-and-coning* using a mini bucket excavator.
3. The 25-tonne 3D stockpile was reshaped into a flat, rectangular surface of uniform thickness. The rectangle was divided, often into a 4 x 5 grid, and increments were extracted using a sided sampling shovel, as frequently depicted in certain ISO standards. This method is akin to increment division or the Japanese slab cake division technique, but write large.
4. A flap sampler was used to divert a stream of IBA-HNF to obtain a sample.

While methods 1–3 offer the practical advantage of allowing the sampler to approach the stockpile directly and perform in situ sampling, their inability to eliminate sampling bias undermines their reliability (Gy, 1979; Esbensen, 2019). Flap gate samplers, as outlined in method 4, act essentially as single-edge cutters and are inherently flawed in terms of increment delimitation, with no viable options for bias mitigation (*ibid*; Pitard, 2020). Such biased sampling techniques produce only ‘specimens,’ rendering them fundamentally unsuitable for commercial analysis. Therefore, it should not be surprising that these approaches have led to many analytical and valuation discrepancies between the producer and the receiver of IBA-HNF, inevitably resulting in frustrations, financial settlement delays, and a loss of trust among the trading parties.

In a newly devised approach, Alfred H Knight was tasked with establishing a centralized sampling hub situated strategically within the logistical supply chain between the IBA-HNF supplier and receiver. At this designated facility, each 25-tonne lot is subjected to weighing, sampling, and final sample preparation for subsequent analysis. The analysis samples are then accepted and trusted by both the supplier and receiver for transaction settlements. This is a radical departure from traditional methodologies, where the sampler would go to the stockpile at either the IBA-HNF production site or the smelter for in situ weighing and sampling. Instead, this innovative approach requires the complete 25-tonne lot to be conveyed to the centralized sampling hub—embodying the concept that “the mountain must come to Mahomet.” This single site approach was inspired by the comprehensive analysis of the conventional “Assay Exchange” paradigm (Esbensen & Vogel, 2023), which was shown to contain inherent weaknesses due to two sampling procedures whose principal uncertainties have been left out of consideration.

In this paper, the focus shall specifically be on issues related to sampling and sample preparation, the steps depicted in Figure 3.

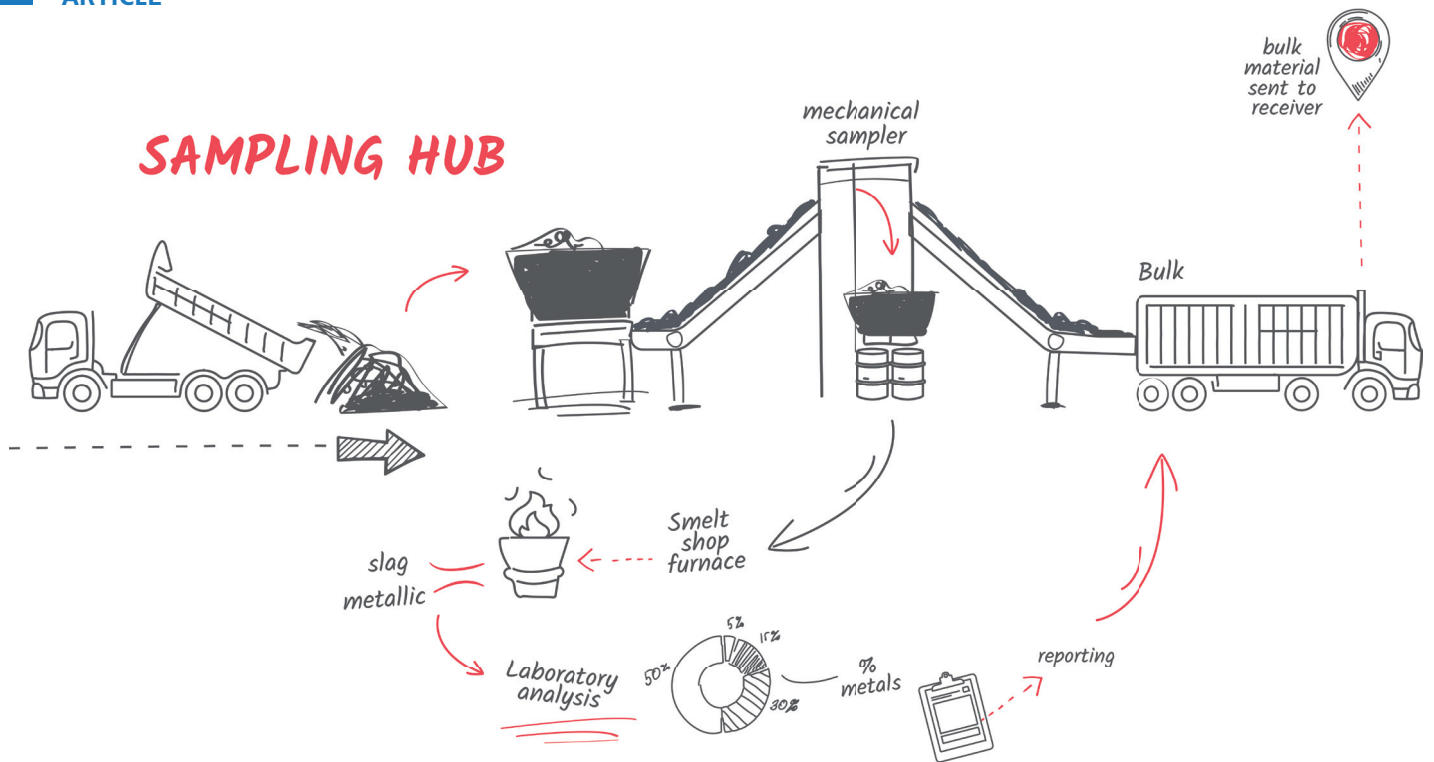

Fig. 3: Graphical illustration of the Sampling Hub in the Netherlands.

## 5. Optimizing One-Dimensional Lot Configuration for Bias-Free Increment Extraction

Bias elimination is achieved when incorrect sampling errors are meticulously eliminated. At the Netherlands-based sampling hub for IBA-HNF, lots of nominally 25 tons are reconfigured into a one-dimensional (1-D) form. Specifically, the IBA-HNF is transported on a conveyor belt in a manner where its length and surface area vastly exceed its width and height, as elaborated in Esbensen (2020). This ensures complete accessibility of the entire lot for increment extraction. Increment slices from this 1-D stream are obtained using a Vezin sampler, meeting the necessary-and-sufficient criteria for removing increment delimitation error (IDE), increment extraction error (IEE), and weighting error (IWE) as outlined by Vogel (2017).

### 5.1 Ensuring Unbiased Sampling through Rigorous Quality Control Measures

As effective quality control to demonstrate that the active mechanical sampling system (MSS) remains free from IDE, IEE and IWE caused by e.g. cutter stopping or slowing down in the stream, a blockage with metal wires, or fluctuating flow-rate of the stream itself, the m/m sampling ratio is monitored on a continuous basis, as per ISO 11790 (2017).

The sampling ratio,  $R_s$ , serves as a critical parameter for assessing the reliability of the sampling process. It is calculated by dividing the actual mass of the sample  $m_A$  in kilograms by the mass of the material it represents  $m_{SL}$  in tonnes multiplied by 1000 as shown in the equation [1]:

$$R_s = \frac{1000 m_A}{m_{SL}} \quad [1]$$

The control chart for the sampling ratio plots this ratio (Figure 5). As all system settings are constant—such as cutter apertures, lot size, and mass flow rate, the sampling ratio demonstrates absence of bias at the MSS of the sampling hub, by:

1. Consistency: A stable sampling ratio plotted on a control chart, suggests a consistent sampling approach. If  $R_s$  remains stable within control limits, the sampling process can be considered unbiased.
2. Process Control: A sampling ratio control chart can quickly highlight instances where the ratio goes out of control, thereby signaling a need for investigation and corrective action. This reactive approach helps in maintaining an unbiased system.





Credit: Alfred H Knight, Holland; used with permission.

Fig. 4: Vezin type sampler in rotating motion, obtaining a TOS-correct full cut of the falling IBA-HNF stream.

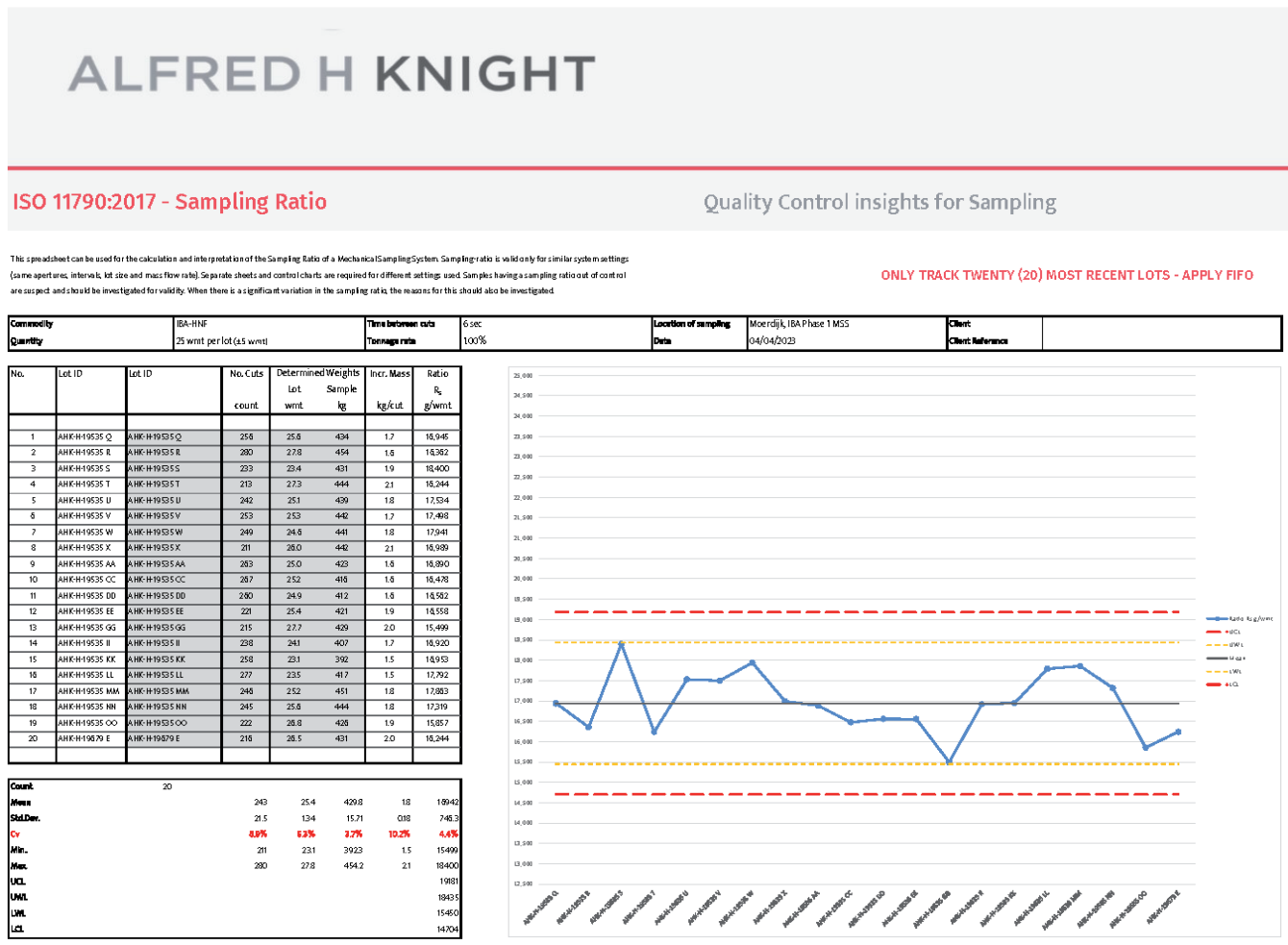

Credit: Alfred H Knight, Holland; used with permission.

Fig. 5: Sampling Ratio control chart

## 6. Optimization and Validation of Sampling and Sample Preparation in IBA-HNF Trade: An ISO 3085 (2019) Based Approach

Given the distinctive composition of each IBA-HNF shipment and the substantial variances between shipments, variographic analysis is unsuitable for sampling process evaluation, as shipments originate from a myriad of concentration levels, varying beneficiation stages, and multiple Municipal Solid Waste Incinerators (MSWI) throughout Europe. Therefore, to evaluate the precision of the sampling process in practice rather than theory at the sampling hub, duplicate samples A and B are formed by alternating cuts of the Vezin sampler.

To establish appropriate overall precision checks in both sampling and subsequent sample preparation, we diverge from the famous Gy's formula and apply ISO 3085 (2019) instead. This standard accommodates variations in lot quality through a practical statistical framework. In the present new methodology, we perform routine sampling and record data for thirty lots on a first-in, first-out basis. Primary sampling cuts by the MSS of each lot are alternated to produce two gross sample portions (composite samples), each of which are independently prepared through induction furnace melting after which a key quality characteristic—metal yield adjusted for metal contained in slag—is determined. It is recognised that this approach may not estimate for the overall precision for certain parameters, such as gold. However, as quality control is consistently applied to every lot and the IBA-HNF industry has predefined *target masses*, it is claimed that the new processing facility operates within a regime that allows acceptable quality parameter checks.

Data for this process, captured in April 2023, is collected in Table 1. The relationship between these precision values is shown in equation [2]. The mean and the range of each pair of measurements is calculated as per equations [3] and [4], and the overall mean and estimated value of overall standard deviation follow by equations [5] and [6] where  $n$  is the number of lots (here 30). The resulting overall precision of sampling, preparation and measurement ( $\beta_{SPM}$ ) is estimated to be twice the overall standard deviation and considers that each sample portion is half of the routine sample and therefore applying division factor of  $\sqrt{2}$ , as per ISO 3085 (2019) as shown in equation [7].

Finally, a statistical upper control limit,  $D_4$ , is applied in equation [8] with a value of 3.47 (the 99% limit for the difference between two independent normally distributed measurements).

By employing this methodology, the calculated  $\beta_{SPM}$  can confirm that our process is tightly controlled within statistically defined limits.

$$\hat{\sigma}_{SPM}^2 = \hat{\sigma}_S^2 + \hat{\sigma}_P^2 + \hat{\sigma}_M^2 \quad [2]$$

$$\bar{x} = \frac{1}{2}(x_1 + x_2) \quad [3]$$

$$R = |x_1 - x_2| \quad [4]$$

$$\bar{\bar{x}} = \frac{1}{n} \sum \bar{x} \quad [5]$$

$$\hat{\sigma}_{SPM}^2 = \frac{1}{2n} \sum R^2 \quad [6]$$

$$\beta_{SPM} = \sqrt{2\hat{\sigma}_{SPM}^2} \quad [7]$$

$$UCL = D_4 \hat{\sigma}_{SPM} \quad [8]$$

Thus calculated, the obtained overall precision for the sample mass stands at 4.20 kg, while for metal yield, it is 2.04%. The upper control limits are 10.30 kg for the range of gross sample mass between portions and 5.00% for the range of metal yield between portions. These results not only meet, but exceed the industry-defined Key Performance Indicators (KPI) for the sampling, preparation, and measurement processes conducted at the AHK Sampling Hub.

**Tab. 1:** Interleaved Sampling Data for Quality Control: Comparing Portion Mass and Metal Yield, 30 IBA-HNF Shipments, April 2023.

AHK Ref.	Mass A (kg)	Mass B (kg)	Mean <sup>x̄</sup> (kg)	Range R (kg)	Yield A%	Yield B%	Mean <sup>x̄</sup> (%)	Range R (%)
19679 H	242.0	243.6	242.8	1.6	93.6	92.3	92.9	1.3
19679 I	215.5	217.1	216.3	1.6	93.6	94.5	94.1	0.9
19679 J	196.8	200.8	198.8	4.0	93.6	93.3	93.4	0.3
19679 K	242.2	238.8	240.5	3.4	79.7	81.0	80.3	1.3
19679 L	236.1	244.7	240.4	8.6	81.4	83.4	82.4	2.0
19679 M	223.4	236.1	229.8	12.7	77.3	80.0	78.7	2.7
19679 N	224.4	223.1	223.8	1.3	81.9	77.6	79.7	4.3
19679 O	225.7	222.3	224.0	3.4	88.4	90.9	89.6	2.5
19679 P	222.9	222.9	222.9	0.0	79.0	79.2	79.1	0.2
19679 BB	215.8	216.4	216.1	0.6	84.4	86.2	85.3	1.7
19679 CC	211.8	212.3	212.1	0.5	82.8	83.0	82.9	0.2
19679 JJ	218.1	220.3	219.2	2.2	81.7	85.2	83.4	3.5
19679 KK	217.0	208.7	212.9	8.3	82.4	84.7	83.5	2.3
19679 M2	199.9	202.2	201.1	2.3	89.0	90.1	89.5	1.1
19679 N2	214.8	213.2	214.0	1.6	88.2	88.4	88.3	0.3
19679 O2	224.5	224.3	224.4	0.2	89.9	90.4	90.1	0.5
19776 A	204.0	207.9	206.0	3.9	90.8	91.8	91.3	1.0
19776 B	214.2	213.1	213.7	1.1	89.8	93.0	91.4	3.2
19776 C	205.2	205.0	205.1	0.2	87.3	93.1	90.2	5.8
19776 E	209.1	208.1	208.6	1.0	81.9	81.1	81.5	0.8
19776 G	206.0	204.1	205.1	1.9	83.8	81.0	82.4	2.8
19776 H	202.1	197.4	199.8	4.7	80.3	80.6	80.5	0.3
19776 I	210.6	211.8	211.2	1.2	90.4	88.8	89.6	1.6
19776 J	206.1	205.5	205.8	0.6	89.1	89.2	89.2	0.1
19776 K	213.6	210.0	211.8	3.6	86.7	85.8	86.3	0.9
19776 L	235.2	243.6	239.4	8.4	89.7	90.4	90.1	0.7
19776 N	205.8	208.7	207.3	2.9	80.8	80.0	80.4	0.8
19776 O	200.6	205.2	202.9	4.6	78.3	76.7	77.5	1.6
19776 P	203.1	203.2	203.2	0.1	84.1	83.7	83.9	0.4
19776 Q	220.9	218.2	219.6	2.7	89.8	88.7	89.2	1.1
$\bar{\bar{x}}$			215.9				85.9	
$\sum R^2$				528.76				124.35

## 7. Conclusion

In this study, we have presented a comprehensive methodology for optimizing and validating the precision of a new TOS-correct sampling and sample preparation approach in the Incinerator Bottom Ash – Heavy Non-Ferrous (IBA-HNF) trade. Beginning with transformation of the 3D lot to a 1D stream, the methodology eliminates common bias-generating sampling errors such as IDE, IEE, IWE (Gy, 1979), by enabling representative sampling by a TOS-correct Vezin cutter. The mass of the resulting sample is at an industrial scale, and its subsequent homogenization process via smelting delivers consistency to the industry. By eliminating bias and adapting the ISO 3085 (2019) standard to demonstrate precision, we achieved a noteworthy 2.04% precision for overall metal yield, which exceeds industry benchmarks and our KPI target. This level of precision instills trust in the commercial settlement values for elements such as copper, gold, silver, platinum, and palladium. These trustworthy values are essential for both the IBA-HNF concentrators and the European smelters engaged in this circular economy material.

This study serves as a critical reference for stakeholders in the IBA-HNF industry, offering insights and actionable solutions for achieving reliable, bias-free, and precise outcomes in sampling and sample preparation. Moreover, the financial implications of this one-stop methodology could potentially improve settlement agreements, contributing positively to the overall trade (Esbensen & Vogel, 2023).

As for future work, we suggest the exploration of this methodology's applicability to other circular economy and electrification metals. The integration of automated systems for further optimization will also be considered. By adhering to the Theory of Sampling (TOS), we point to how this development work and this study contributes its part to the United Nation Sustainable Development Goals 9 and 12, promoting innovation, sustainability, and responsible consumption and production.

## References

- Born, J.P., 2018a. "Mining IBA for Precious Metals." VDI Conference on Metals and Minerals Recovery from IBA, Düsseldorf, November 8, 2018.
- Born, J.P., 2018b. "Mining Incinerator Bottom Ash for Heavy Non-Ferrous Metals and Precious Metals." In: Holm, O., Thomé-Kozmiensky, E. (Eds.), Removal, Treatment and Utilisation of Waste Incineration Bottom Ash. TK Verlag, Neuruppin, pp. 11–24.
- CEWEP, 2023. "Bottom Ash Factsheet." Confederation of European Waste-to-Energy Plants. Retrieved September 30, 2023.
- Chimenos, J.M., Segarra, M., Fernández, M.A., and Espiell, F., 1999. "Characterization of the Bottom Ash in Municipal Solid Waste Incinerator." *Journal of Hazardous Materials*, 64, pp. 211–222.
- Dou, X., Ren, F., Nguyen, M.Q., Ahamed, A., Yin, K., Chan, W.P., and Chang, V.W.C., 2017. "Review of MSWI Bottom Ash Utilization from Perspectives of Collective Characterization, Treatment and Existing Application." *Renewable and Sustainable Energy Reviews*, 79, pp. 24–38.
- DS3077, 2013. "Representative Sampling – Horizontal Standard." Available at DS Webshop.
- Esbensen, K.H., 2020. *Introduction to the Theory and Practice of Sampling*. IMP Open, Chichester, UK. ISBN: 978-1-906715-29-8.
- Esbensen, K.H. and Vogel, D.A. (2023) "The Elephant in the Room – Unsubstantiated complacency re. the "assay exchange" paradigm: sampling uncertainties with hidden economic consequences". *The ALCHEMIST*, Issue 110 (July 2023) <https://www.lbma.org.uk/alchemist/alchemist-110/the-elephant-in-the-room>
- Eurostat, 2023. "Municipal Waste Statistics." Available at Eurostat. Accessed September 29, 2023.
- Gy, P., 1979. *Sampling of Particulate Materials Theory and Practice*. Elsevier: Amsterdam.
- Hyks, J. and Hjelmar, O., 2018. "Utilisation of Incineration Bottom Ash (IBA) from Waste Incineration – Prospects and Limits." In: Holm, O. and Thomé-Kozmiensky, E. (Eds.), Removal, Treatment and Utilisation of Waste Incineration Bottom Ash. Thomé-Kozmiensky Verlag GmbH, Neuruppin, pp. 11–23.

ISO 3085, 2019. "Iron ores — Experimental methods for checking the precision of sampling, sample preparation and measurement." International Organization for Standardization.

ISO 11790, 2017. "Copper, lead, zinc and nickel concentrates — Guidelines for the inspection of mechanical sampling systems." International Organization for Standardization.

Lyman, G.J. Theory and Practice of Particulate Sampling: An Engineering Approach. Materials Sampling & Consulting Pty Ltd. ISBN 1646333829, 9781646333820

Pitard, F.F., 2019. Theory of Sampling and Sampling Practice, 3rd Edition. CRC Press, Taylor & Francis Group. ISBN: 978-1-138-47648-6.

Šyc M, Simon FG, Hykš J, Braga R, Biganzoli L, Costa G, Funari V, Grosso M. Metal recovery from incineration bottom ash: State-of-the-art and recent developments. J Hazard Mater. 2020 Jul 5;393:122433. doi: 10.1016/j.jhazmat.2020.122433. Epub 2020 Feb 29. PMID: 32143166..

United Nations, 2015. "Transforming Our World: The 2030 Agenda for Sustainable Development. A/RES/70/1." Accessed September 30, 2023.

Van Caneghem, J., Van Acker, K., De Greef, J. et al., 2019. "Waste-to-Energy Is Compatible and Complementary with Recycling in the Circular Economy." Clean Technol Environ Policy, 21, pp. 925-939.

Vogel, D.A., 2017. "Access, Select, Include – A Review of the Commercial Sampling of Traded Bulk Commodities in the Context of Gy's Theory of Sampling." Proceedings of the Eighth World Conference on Sampling and Blending, pp. 367-378. The Australasian Institute of Mining and Metallurgy: Melbourne.

Vogel, D.A. and Esbensen, K.H., 2021. "WHAT Are Sampling Errors—and WHAT Can We Do About Them? Part 2: Sampling and Weighing—Different, but the Same..." Spectroscopy Europe, IM Publications Open LLP, p. 28. doi:10.1255/sew.2021.a16.

## Maximise Your Outreach with SST Sponsorship!

Become an SST sponsor: Elevate your presence issue by issue or secure extended visibility across consecutive editions. Connect with our diverse readership through SST. Unleash the power of strategic sponsorship with SST and leave a lasting impact on your audience!

For rates and exclusive sponsor advertising opportunities, reach out to our Publisher today.

**Advertising Sales and Sponsorship Coordination:**  
Benedikt Dolzer and Kim H. Esbensen

✉ [advertisement@sst-magazine.info](mailto:advertisement@sst-magazine.info)



# Tribute to Ian Michael (1958–2023)

## Publisher extraordinaire

By Kim H. Esbensen

DOI: 10.62178/sst.001.007

### 1. IM Publications

The publishing house IM Publications Open, Chichester, UK has over 40 years of outstanding achievements. The company's outreach to the market can be found on the website: [www.impopen.com](http://www.impopen.com)

Another, much favored meeting place, was at the nearby pub "The Fox Goes Free." If anything, such locales only expedited, and made the hard editorial work much more pleasant.

### HERE IS THE COMPANY'S OWN MASTHEAD:

IM Publications Open (IMP Open) is a specialist publisher of books and open access/free-to-read periodicals, primarily in analytical chemistry. We are focused on ensuring that we provide a first-rate, personal service to all our customers—authors, editors, book buyers. As the world of publishing becomes increasingly dominated by larger and larger corporations, this approach from a smaller company is much appreciated. In addition, we publish and market a number of books in the fields of near infrared (NIR) spectroscopy, mass spectrometry, surface analysis, sampling and chemometrics.

We also publish proceedings of conferences on behalf of the organisers. Examples include the "Proceedings of the XIII International Conference on the Applications of Magnetic Resonance in Food Science", "Proceedings of the 18th International Conference on Near Infrared Spectroscopy" and "Proceedings of the 7th and 10th World Conferences on Sampling and Blending."

Ian Michael's commitment to professional collaboration with authors and editors knew no boundaries! His main arena was analytical chemistry in general, spectroscopy in particular, the latter with a clear focus on Near InfraRed spectroscopy. But the scope of interest was wide, very wide, reflecting on Ian's own widely ranging interests.

### 2. Conducting business

IM Publications often did business in an unusual manner. While normally, authors and editors would have to pay a visit to the Publisher's domicile for working sessions (never mind that many of these could be managed as internet affairs), it was just as well the case that when complex hands-on work was on the agenda, Ian was not shy of reversing the whom-visits-whom regimen, Figure 1.

### 3. IM Publications – invaluable help and support for IPGSA

The impact of Ian Michael's influence on the development of the barely 20-year-old organised scientific community of sampling has been overwhelming ... How did this come about?

Well, the start has all to do with the discipline of NIR analysis, which is much closer to Ian's own training and expertise – spectroscopy. In a career mostly dabbling with chemometrics, in 2015 I was invited as keynote speaker at the prestigious NIR world conference, NIR2015, Iguazu, Brazil ... possibly because I had inserted myself as a speaker at the preceding NIR2013 conference, with the intent of rattling the NIR cage, re. the importance of knowing at least something about sampling – before analysis.



**Fig. 1:** Ian Michael – editorial session, at a coffee bar at Heathrow airport 2019, “situated just about midway between Copenhagen and Chichester, travelling times considered”.

Thus, I met Ian for the first time at the NIR 2013 world conference in La Grande Motte, near Montpellier, France. Enjoying the well-known camaraderie and ambience in the NIR community, one afternoon my path happened by the exhibition hall, and as fate would have it, I gravitated to a stand manned by Ian, whom I at this time only knew as the publisher of NIR News, which I had marveled at and envied, for many years. “Such an effective, easy-on-the-eyes communication platform for the NIR community!” was my first opening comment.

In parallel, at this time, I was heavily engaged in trying to organize a very different scientific community, the world sampling community, from which we often looked enviously to our NIR freres because of the long-standing tradition of successful, well-organised world conferences, the elegant NIR News, and a Council working hard and professionally for the common good with regular, high-quality world conferences. “What’s not to like? We samplers should be able to do the same!”

Suddenly, in a spontaneous move, I blurted out: “Ian, there are many parties outside the NIR community who admire the NIR News and the community it serves – Do you have room for one more?”

Ian: “One more what?”

KHE: “One more scientific society!”

Ian: “Well, yes of course, why not? – Love to!”

And with that small step, with Ian’s characteristic kind interest in helping out with scientific endeavors, what became *TOS forum*, the SAMPLING column in *Spectroscopy Europe* and later a successful sampling textbook was already well under way. This first step included my bold suggestion that we simply steal the layout, format, and design of the well-accomplished NIR News (at that time some 15 years on the road already) – pure highway robbery! It so happened that this spoke directly to Ian’s pride over his NIR child.

NIR 2015  
Brazil  
Highlighting South America



**Fig. 2:** “The Critical Role of Representative Sampling before Analysis, NIR or Otherwise”.

Directly after this chance encounter, a first accord was soon outlined, without which the community affairs of the world sampling community would have been much different. The organised affairs of the International Pierre Gy Sampling Association (IPGSA) owe an enormous debt of gratitude to Ian for his immediate, and very kind willingness to help. I am also sure, that his satisfaction in the responsibility as Publisher and Editor found this new diamond-in-the-rough irresistible.

In the following short time span of just a decade, it has been an enormous privilege to collaborate with Ian on many projects. At first the series of *TOS forum* issues, but very soon he also invited me to start up a blogging column on sampling issues (complete writer's freedom). He mentioned, again with pure and well-earned pride, that he had several other column enterprises running with highly creative and successful editors. So, again, why struggle to invent a new thing, when it has already proven itself over many years?

Soon, a virtual conveyor belt of SAMPLING columns saw the light, comprising a convenient short-story format for explaining the intricacies of the Theory and Practice of Sampling (TOS); this was exactly the kind of work I was excited about doing. The first column appeared in the February 2014 SE-26(6) issue, and only twice since then did we miss out on this commitment – Damn ;–]

#### 4. An introductory textbook

But what was not planned originally, dawned upon me after the first SAMPLING 25 columns: Here was a full curriculum for an “Introduction to TOS”, but for the NIR community ‘only’. Surely, there would be interest for this topic also beyond the fence line ... In fact, this opportunity fitted very well with the course of my personal career re. sampling, and how to reach out to ever broadening scientific, technological and industrial circles. And so, the idea of a textbook was born. Yet, from a handful of individually conceived column formats to an organised textbook, was a very long stretch. There would have to be an enormous editing job, dressing it all up to be more consistent and tying it all together properly.

In this work, Ian came forth with a plentitude of inspiration and creativity and supplied an enormous drive. The 2020 textbook: “Introduction to the Theory and Practice of Sampling” would never have seen the light were it not for his unflagging collaboration spirit, and efforts. Also, it was clearly right up his alley, to have a free hand to design a new book layout, format, style from scratch. Never was there a more perfect collaboration, as I was in the beginning mostly interested in the subject-matter (TOS) and the scientific storytelling – while gladly (to put it mildly) relinquishing all the technical design, editing, collating, typesetting, and laying out a plethora of illustrations and references to be left in Ian's very capable hands. There was no wish he would not try to honor; I only recollect two times, when yet another wild idea was met with a “Sorry, No,” absolutely justified from a publisher's point of view.

To be honest, the book also benefitted enormously from Ian taking charge of the language used by the author; many were the times that the author's wish for some more colorful language than in ‘your ordinary, dull textbook’ did not reach the final printing: “There are limits to flippancy in the books I produce”. Still more than enough reached the finishing line, so ultimately the book met with both our satisfaction as an unconventional endeavor. All in all, including standing corrected quite often linguistically, it was pure joy doing this project in solidum.

This prestige project textbook was proudly launched in February–March 2020, just in time for ... COVID ... Well, instead of despairing, we thought that a global pandemic might allow some scientists, some technologists, some industrialists ... a little extra reading time. So, forced by the global lockdown, we immediately started on our next joint project: How to market this new book effectively? To what degree we succeeded, history will eventually be the judge, but right up until spring 2023, there were no complaints in either Copenhagen, nor in Chichester. This marketing endeavor turned out to be just as interesting and challenging as writing and producing the book in the first place.

I count the work behind this textbook among my most happy professional career experiences. All our many hundreds of e-mail ping-pongs, SKYPE sessions – and the vital, in-person meetings reign supreme in terms of professional friendship, mutual respect, and general good living.

#### 5. IPGSA salutes a desktop publishing giant

THANK YOU, Ian Michael, for being there for the small niche endeavor of sampling. What started out professionally as a side bar in relation to Ian's main interest and work for analytical chemistry, spectroscopy, and NIR, meant the world to the International Pierre Gy Sampling Association. Ian was also instrumental with respect to helping the community concerned with hyper-spectral image analysis; see IM Publications homepages: <https://www.impopen.com/>

THANK YOU, Ian Michael, for midwifing 50+ SAMPLING columns, concluding with SE35-2, which happened to be on a topic of close personal interest for more than two years. We also concluded editorial work on one more column just two days before Ian lost his brave battle with leukemia (appearing in what was scheduled to be SE35-3). With permission from Ian Michael's estate, we are in the position to bring a *simile* of this last SAMPLING column ever produced (see Appendix).



This was to have been the first column on historical sampling topics, courtesy by the inspiring American sampling scholar Alan Rawle.

THANK YOU, Ian Michael, for eleven comprehensive issues of *TOS forum*, an introductory sampling textbook, which from autumn 2023 will be available as an E-book (thanks to Katie Michael), two impeccably produced Sampling World Conference Proceedings as well as the special publication: *Economic Arguments for Representative Sampling* in a special issue of *Spectroscopy Europe* in 2021. These three publications represent Ian’s well-contemplated efforts to come up with a modern facility for documentation of scientific conferences and similar directed publications, reflecting so well the company’s aspirations – and notably at a significantly reduced cost, and with markedly shorter production times than conventional approaches. In fact, the Proceedings from WCSB7 and WCSB10 and the “Economic Arguments ...” were a source of considerable professional pride for Ian – and we could not agree more.



Credit: Katie Michael; used with permission.

Today they are a leading-edge asset for the IPGSA.

We are forever in debt to your intellect, interest, creativity, kindness, and overwhelming professionalism.

R.I.P. Ian Michael

### APPENDIX

With permission from Ian Michael’s estate, we are in the position to bring a simile of this last SAMPLING column ever produced, taken from *Spectroscopy Europe* Vol. 35 No. 3 (2023). The column can be found on the following pages in its original layout.

## TOS forum

Starting 2024 *Sampling Science and Technology* (SST) is a direct continuation of *TOS forum*, which was published by IMPublications in the decade 2013–2023.

The complete archive can be found here:

[impen.com/tos-forum](http://impen.com/tos-forum)

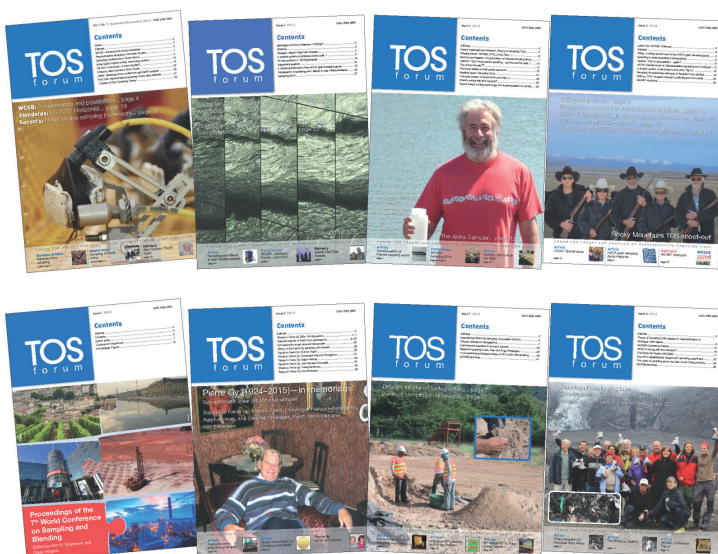

## SAMPLING COLUMN

# Giants of sampling 1: Henry Augustus Vezin

Alan Rawle

Malvern Panalytical Inc., Westborough, MA 01581, USA

This column begins a historical track with the present inaugural feature on a true giant, Henry Augustus Vezin. We have asked the prolific compiler and commentator on all matters of early sampling history Alan Rawle for a fascinating opening article. And he is not letting the readership of this column down. Please enjoy his eminent first contribution.

## On shoulders and giants

A much-parodied remark relates to scientists, and thus science, moving forward because they are standing on the shoulders of learned giants. The remark is often attributed to Isaac Newton, but from Wikipedia we learn that the quote may go back much further than Newton's time:

John of Salisbury wrote in his *Metalogicon* in 1159: "Bernard of Chartres used to compare us to dwarfs perched on the shoulders of giants. He pointed out that we see more and farther than our predecessors, not because we have keener vision or greater height, but because we are lifted up and borne aloft on their gigantic stature."

## Historical background

This quotation (or a parody of it) probably applies very well in the Theory of Sampling (TOS) where the work of early pioneers has had major influence on what is practiced today. Some of these early giants

of sampling include David Brunton, Sylvanus Albert Reed, Henry Vezin, Robert Hallowell Richards (possibly his first wife, Ellen Swallow Richards, should be more famous) and Philip Henry Argall ("PHA"). A common theme was association with the gold and silver mines in Colorado where accurate sampling and analysis often meant the difference between success and failure of that mine. These early pioneers, although successful in their respective mining fields, made their fortunes in other ways—David Brunton with a pocket compass, Sylvanus Albert Reed with the metal aircraft propeller, Robert Hallowell Richards through his work at MIT especially with his learned books on mining practice and Phillip Henry Argall supposedly the inventor of the 8-hour shift and cyanidation.

The one exception in terms of (lack of) fortune accumulation was probably Henry (Augustus) Vezin. Henry Vezin was different. He made little money, giving away engineering drawings for his (Vezin) sampling device which then could be built for as little as \$200. He patented and published virtually nothing in his lifetime but was extremely well-known and renowned in the mining profession. Even pictures of him are hard to come by. On death it was stated by "P.H.A." (probably Philip

Henry Argall) in *The Engineering and Mining Journal*, "We publish a short notice of Mr. Henry A. Vezin, prepared by one of the many young fellows whom he delighted to help. He was characterized by an unflinching courtesy and patience in the giving or procuring of information when consulted by any brother professional and, being a very careful man, he was found to be a good authority on many matters." Let's explore the life of Henry Vezin as it was full of many interesting events, tragedies and insights.

## The family Vezin

Henry Vezin was born on 8 March 1836, the 7<sup>th</sup> child in a family of 14. His father, Charles Henri Vezin, was famed for bringing chess to Philadelphia. His mother, Emilie (née Kalisky), was probably only 18 on marriage (Charles was 39) and died tragically in what was termed "The Burning of the Austria" on passage from Hamburg to New York City on 13 September 1858 together with two of his younger sisters Mary (17 or 18) and Clara (aged 8). This was one of the great maritime tragedies of the nineteenth century with over 500 perishing. A brother, Alfred, survived by swimming for several hours in the sea. Although three of his (male, of course) siblings (Charles, Hermann

DOI: [10.1255/sew.2023.ax](https://doi.org/10.1255/sew.2023.ax)

© 2023 The Authors

Published under a Creative Commons BY licence



# SAMPLING COLUMN

and Oscar) attended the University of Pennsylvania. Henry, apparently, did not attend university. Obviously, he graduated in the school of life... His brother, Hermann, became a famous actor in England. Another brother, Charles, also known as "Fast Charlie", led a more checkered life. He was in business in PA and was German consul (1867–1871) in Philadelphia. Subsequently, he went bankrupt and "escaped" ("took French leave") to South America, then to England and onto South Africa where he died on 11 February 1882 (found dead down a well in Port Elizabeth).

Henry got into mining early. At the age of 15 he travelled to Germany where he apparently studied the topic before returning to Philadelphia in 1858. In 1861 family portraits as CDVs (*carte de visites*) were commissioned from the photographers, F. Gutekunst, 706 Arch Street, Philadelphia. Henry is shown below looking very different to the pictures shown in his obituary (Figure 1).

He and two of his other brothers (Oscar and Alfred) served with distinction in the American Civil War. Henry joined the service as a Captain Company G, Fifth Pennsylvania Cavalry on 27 March 1862, and was mustered out on 8 June 1865. Henry then had the rank of (brevet) Lt Colonel—a rank

that gives a commissioned officer a higher rank title as a reward for gallantry or meritorious conduct, but without receiving the authority, precedence or pay of the real rank. On one occasion he and a group of 12 men was said to have put to flight over 100 rebel soldiers. However, it does appear that he was using his mining experience in planning out and constructing trenches and rifle pits as we have correspondence from him with the title "Acting Assistant Engineer".

## On sampling in particular

We now come to the important (and interesting!) part and the involvement of Henry Vezin with sample theory and sampling practice. There is some confusion in this matter as we will see. Figure 2 is from Robert Richards' classic texts on *Ore Dressing*, in Volume 2, p. 850.

We note that in 1866 Vezin was still living in Philadelphia (the tax records for the city below indicate this) prior to a move to Nevada in 1870 or 1872 or so.

The simplest rule, adopted by Vezin<sup>14</sup> in 1866, is: first, to decide what weight ( $w$ ) should be taken for assay or analysis after the ore has been ground to 100-mesh (approximately 0.125 mm. diameter); second, to compute the number ( $n$ ) of maximum sized grains passing through a 100-mesh screen that would weigh ( $w$ ); and third, to cut down to a weight after each crushing which will be equal to  $n$  of the maximum sized particles.

This rule may be said to use a constant number of particles whatever their size. The following figures show the weights of different sizes required by this rule on the basis of 0.1 assay ton (2.917 grams) of ore through a 100-mesh screen (0.125 mm.):

128	mm.	3,131	metric tons.
64	"	391	" "
32	"	48.9	" "
16	"	6.12	" "
8	"	764.6	kilos.
4	"	95.57	"
2	"	11.95	"
1	"	1.493	"
0.5	"	186.7	grams.
0.25	"	23.33	"
0.125	"	2.917	"

The above rule demands finer crushing than practice indicates to be necessary, and it is, therefore, more expensive than is wise.

**Figure 2.** Extract from Robert Richards' *Ore Dressing* (1909) Volume 2 page 850 indicating minimum masses required for sampling materials of different (top screened) sizes.

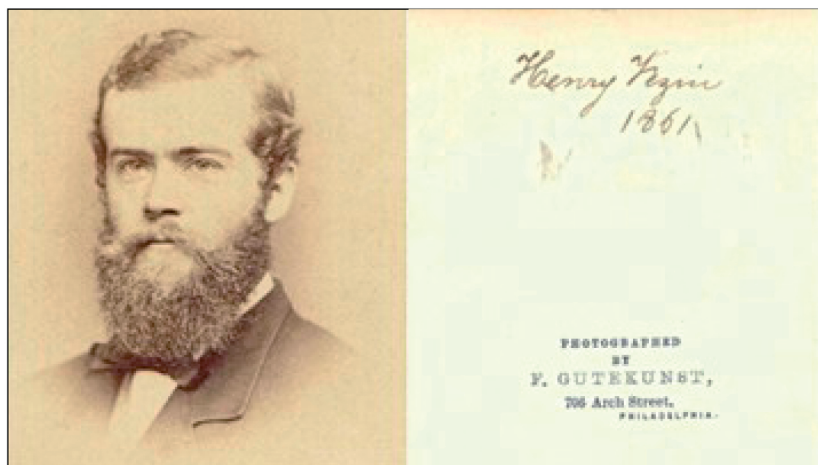

**Figure 1.** Henry Vezin's *carte de visite* from 1861.

When we examine Reference 14 in Roberts' tome, we find it refers to Heinrich Hofman (a compatriot professor to Roberts at MIT) and Hofman's book on the *Metallurgy of Lead* in 1892<sup>1</sup> (later editions in Google Books omitted the sampling section) gives a Vezin 1866 attribution with the following unreferenced statement "Vezin, in 1866, finding that with pyritic ores of Gilpin County, Colo., running from 1 to 4 oz of gold per ton, it was safe to cut down to 1 oz, a sample that had passed a 20-mesh screen, the diameter of the largest

# SAMPLING COLUMN

particle being 1 mm (1/25 in.)” Hofman actually refers back to Sylvanus (Albert) Reed and David Brunton (with much later dates) for more rigorous calculations. The date of “1866” is puzzling for other reasons—it’s at least 20 years before others such as Brunton and Reed would be discussing sampling in the AIME journals and there is no mention or writings elsewhere (in particular, A.W. Warwick’s *Notes on Sampling* ghosted by Veizin)<sup>2</sup> of theoretical or practical sampling around the mid-1860s. There is no similar table anywhere in the literature dating from this time or even after. However, the indication that numbers of particles are key and that it’s the top end of the distribution that dictates the minimum sample mass is obvious from this text. Numbers and standard errors are, of course, synonymous in statistical analysis. Simple analysis of the masses shown above indicate that these are calculated using a standard error of 1% on the  $x_{99}$  point of the particle size distribution for a material with density  $2.6 \text{ g/cm}^3$  (Table 1).

A slight change of density to that approaching dolomite (a common gangue material in Colorado) would account for this constant 10% discrepancy between Robert’s tabulated figures and those calculated via the  $x_{99}/1\%$  SE route. We

also note that Richards considered these calculated masses as too excessive and later uses a mass proportional to (diameter<sup>2</sup>) to reduce these to values he considered more practical. This set back sampling theory by about 50 years until Pierre Gy would retrieve the statistical situation.

In 1870, Veizin (aged 34) is shown on the Summit, CO portion of the US census as a white (W) male born in Pennsylvania with father and mother shown as foreign birth, and “not deaf, dumb, blind, insane or idiotic”. The value of his “personal estate” appears to be \$20,000 with profession given as engineer. So, it appears Veizin was pretty successful in the 1866–1870 period increasing his income by more than seven-fold in that five-year period. Veizin was the mechanical engineer for the Boston Silver Co., with a mine located near Saint John’s, Summit County, Colorado and it was stated that the plant was a failure until Veizin took charge of it in 1872. It must have been around this time when Veizin produced what was probably his best gift (literally) to the mining industry—the so-called Veizin sampler or simply “The Veizin”. This conforms to the golden rules of sampling—all of the production stream is taken for a period of time and that the sample is moving (not static) when taken. He did

appear to return to Philadelphia in the 1874–1880 period apart from an 18-month stint in the Russian coalmines and iron ore fields where we learn that he spoke three “modern languages” excluding Russian (probably English, French and German).

Apparently, his “most important foreign work” was on the first Nicaraguan Canal survey under a French company, but further research is needed here to quantify his contribution.

## Focus on technology

There are a number of videos indicating how the Veizin sampler operates, and these can be seen on YouTube. Likewise, the entry “Veizin samplers” on Google will supply an overwhelming abundance of illustrations and descriptions (see Fact box below).

The construction of the sampler is relatively simple (Figures 3 and 4).

Other (earlier) references quote an installed price at around \$100.

Veizin was very meticulous and kept detailed notes. These notes (called “tapeworms” by Veizin) became the basis for a set of 18 articles in the *Denver Mining Reporter* which subsequently were compiled into a classic volume called *Notes on Sampling* by A.W. Warwick with a publication date of 1903. Veizin had requested that the articles be published anonymously. This historical gem can be downloaded for free (showing the apparent value of practical scientific information!) as a 44-page Google book.<sup>2</sup>

Veizin never married and thus had no heirs. He died at a relatively young age (66) on 27 December 1902 of a heart complaint (“angina pectoris”) and was interred at the family plot in Laurel Hill, Philadelphia, PA. We learn from his obituary in *The Engineering and Mining Journal* (Saturday 10 January 1903; what journal is published on a Saturday these days?!) that “Mr. Veizin was distinguished by his

**Table 1.**  $x_{99}$  1% SE (99% confidence limits) density =  $2.6 \text{ g/cm}^3$ . Needs 10,000 particles and this represents 1% of the total mass of the system.

$x_{99}$ 1% SE (99% confidence limits) density = $2.6 \text{ g/cm}^3$ Needs 10000 particles and this represents 1% of the total mass of the system							
x ( $\mu\text{m}$ )	x/10000	x <sup>3</sup>	Density ( $\text{g/cm}^3$ )	10000*100*( $\pi/6$ )	Minimum Mass (g)	Veizin (1865/1866)	Veizin/Rawle
1	0.0001	1E-12	2.6	523598.7756	0.000001		
10	0.001	1E-09	2.6	523598.7756	0.001361		
100	0.01	0.000001	2.6	523598.7756	1.36		
125	0.0125	1.9531E-06	2.6	523598.7756	2.66	2.92	1.10
200	0.02	0.000008	2.6	523598.7756	10.89		
250	0.025	1.5625E-05	2.6	523598.7756	21.27	23.3	1.10
500	0.05	0.000125	2.6	523598.7756	170.2	186.7	1.10
1000	0.1	0.001	2.6	523598.7756	1361.4	1493	1.10
1500	0.15	0.003375	2.6	523598.7756	4595		
2000	0.2	0.008	2.6	523598.7756	10891	11950	1.10
4000	0.4	0.064	2.6	523598.7756	87127	95570	1.10
5000	0.5	0.125	2.6	523598.7756	170170		
8000	0.8	0.512	2.6	523598.7756	697015	764600	1.10
10000	1	1	2.6	523598.7756	1361357		

Veizin referenced in Richards' Ore Dressing  
Volume II Page 850

# SAMPLING COLUMN

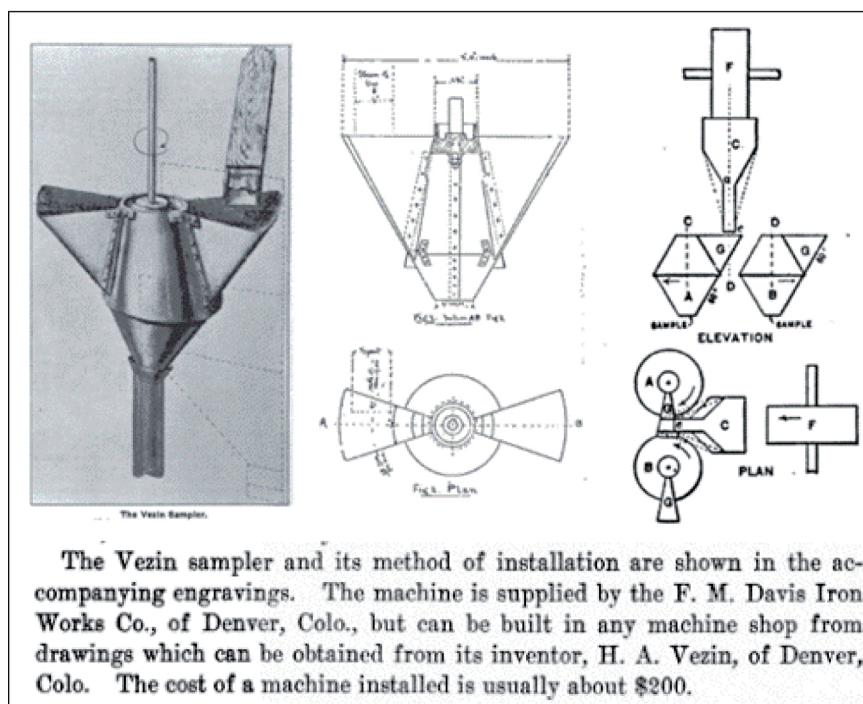

Figure 3. Construction of the Vezin sampler.

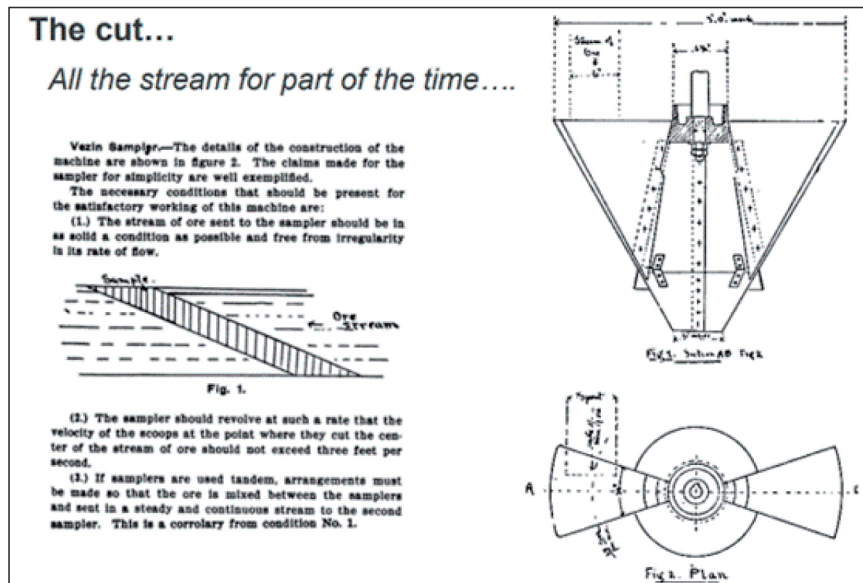

Figure 4. Extract from Reference 1 indicating the type of cross-cut sample taken and the construction of a Vezin Sampler.

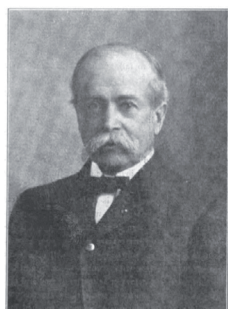

Figure 5. Obituary photo of Henry Vezin.

unusual knowledge of his profession down to the minutest detail, as well as by his tenacity of purpose in following out a subject to its finality”.

His legacy is here to see for everybody, and his contribution to both the theory and practice of sampling is not difficult to measure—it is immense!

**Fact box: The Vezin sampler: a success story *sine qua non***

**Part 1: YouTube video from CSIRO**



**Part 2: Internet search on “Vezin samplers”**

Choose your favoured search engine!

**Part 3: Webinar on Henry Vezin**

*Henry Vezin and Early Sampling Practice (1850s–1900)* (requires free registration). <https://www.malvernpanalytical.com/en/learn/events-and-training/webinars/W140904SamplingPractice.html>

## References

- H.O. Hofman, *The Metallurgy of Lead and the Desilverization of Base Bullion*, 5<sup>th</sup> Edn. The Scientific Publishing Company (1899). <https://tinyurl.com/mrx3xak7> N.B. The 1892 edition is not available, so I go with the 1899 edition). Note that the sampling section was omitted from later editions of the book (not as seemingly indicated as later editions of the Google Book).
- A.W. Warwick, *Notes on Sampling*. Industrial Printing and Publishing Company (1903). <https://tinyurl.com/5fmmtw5u>

# Geoffrey Lyman (1948–2023)

By Kim H. Esbensen

DOI: 10.62178/sst.001.009

We are deeply saddened to share the news of the passing of Geoff Lyman, a distinguished alumnus of McGill University and a stalwart of the Julius Kruttschnitt Mineral Research Centre (JKMRC) coal flotation team. Geoff's unparalleled contributions to the field of Chemical Engineering and his extensive research over three decades at the Centre have left an indelible mark. Geoff was known for his exceptional ability to tackle new problems and devise innovative solutions. He designed and built the first coarse coal ash analyser, later commercialised as COALSCAN, setting a significant milestone in the industry. His research encompassed a broad range of topics, including coal dense medium cyclones, control systems for commercial coal jigs, turbulence effects in coal flotation, application of geostatistics for coal washability analysis, dynamic simulation of process flowsheets, modelling of mineral textures, and the development of sampling techniques and associated analysis. After his tenure at UQ, Geoff leveraged his expertise to establish a successful consulting business, continuing to contribute significantly to the field. Geoff, known for his perfectionism and his hearty laugh that resonated across the Centre, will be profoundly missed. Our deepest condolences go out to Geoff's family, friends, and colleagues. His legacy will continue to inspire and guide the mineral processing scientific society in its future endeavours.

 **Mohsen Yahyaei** Director, University of Queensland

Terribly saddened to hear the news! I was fortunate to have Geoff as one of my doctoral thesis supervisors at the JKMRC. He was a very knowledgeable man and was always willing to share his wealth of wisdom. I have learned a lot from Geoff. I still fondly remember the many conversations we've had over the years. He had a great sense of humour and a very hearty laugh! Always had an anecdote or joke up his sleeve to lighten the mood. His passion for mathematics and for sampling were second to none. A great loss for the scientific community indeed. May Geoff's soul rest in peace.

 **Vijay Subramanian**



**Fig. 1:** Geoffrey John Lyman  
\* 28 June 1948  
† 28 September 2023

Thank you for sharing this sad news Mohsen. I remember very clearly passionate discussions with Geoff on the art, science, statistics and mathematics of sampling. My condolences to all who were close to Geoff.

 **Mark Noppé**

RIP Geoff, you'll be dearly missed, scientifically and personally...

 **Florent Bourgeois**

Very sad news. As a student at the JKMRC in the 1980s, the “Lyman Radius” was well recognized as the perimeter needed to fall outside of earshot of his booming laughter. Long will I remember Geoff for his ability to laugh wholeheartedly. He is someone you cannot readily forget, nor should you...RIP.

 **Adrian Dance**

Thanks for the update. I had Geoff as a supervisor. The first half year we had a pretty hostile relationship (I guess two strong alpha males). But once we settled down we had a great relationship. He certainly was an interesting character and very passionate. He was not well understood by others – and I ended up finding myself in agreement with him far more often than not. He had many funny stories. One of my favourites was him talking about his Masters. He finally finished his Masters and decided to submit and then said to himself ,nah’ and wrote the whole thing again from scratch. A year later he was now very pleased with the new version, but then said ,nah’ and did it again. Finally he submitted. He was a perfectionist way off the scale. Both my supervisors: Bill Whiten and Geoff Lyman have now passed away – and the world is a much less lively place.

 **Stephen Rayward**

Indeed this is very sad news and I’m lost for words in responding to Geoff’s passing. He was incredibly smart as many of us who met Geoff would know, but he was equally brilliant as a chef and host. So whether you needed a Lagrangian solution to your least squares mass balance or a recipe to a Gruyère soufflé, Geoff was the person to see.

My sincere condolences go out to his dear family and friends, as he will be sorely missed. I was lucky to have known Geoff. May he rest in peace.

 **Toni Kojovic**

I can always remember Geoff telling me that we don’t teach engineers enough maths and statistics – as part of a sampling course he taught for Trail Operations. I really respected his work in this field and then actually going and getting stuff made that lived up to his high standards. What a great loss – to the industry and his family and friends. RIP Geoff.

 **Rob Stephens**

I was saddened to hear of Geoff’s passing. Whist I did not know him well, we had met at various WCSB and Sampling Conferences in Australia and elsewhere. His knowledge and enthusiasm for sampling science were without bounds, along with his mathematical treatments! It was fitting that his two last papers were published in the journal Minerals around the time of his passing. Even to the last, his writing resulted in much robust discussion by the reviewers. His book published in 2019, will be a lasting testament to his achievements in the field of sampling. RIP Dr Geoff Lyman.

 **Simon C. Dominy**

#### VALE GEOFF LYMAN

I was deeply saddened to hear of the passing of Dr Geoff Lyman, a leading authority and creative thinker on the theory of sampling, quality control and quality assurance. After completing his Bachelor and Master of Engineering studies at McGill University in Canada, Geoff moved to the University of Queensland (UQ) where he completed a PhD in Mineral Processing Control and Instrumentation. He subsequently spent more than 33 years at UQ’s Julius Kruttschnitt Mineral Research Centre (JKMRC) carrying out research in coal and minerals processing, including coal washing, flotation control, on-line analysis, dense medium cyclone circuit design and jigs. This kindled his life-long interest in the impact of material heterogeneity on all aspects of mineral sampling and analysis. In 2000 Geoff branched out and set up his own consulting company, Materials Sampling & Consulting Pty Ltd based in Southport, Queensland, where he spent the rest of his life. Geoff’s work has been spread across an impressive range of industries, including precious metals, diamonds, coal, iron ore, base metals, catalysts, grain and meat. Major achievements include development of the first on-line coarse coal ash analyser and more recently publication of a new textbook on sampling. In recognition of his standing in the sampling community, Geoff was awarded the prestigious Pierre Gy Sampling Gold Medal at the 9<sup>th</sup> World Conference on Sampling and Blending held in Beijing, China, in 2019. Geoff was also a foundation member of the Advisory Group of the International Pierre Gy Sampling Association (IPGSA) since its inception. My condolences go out to Geoff’s family, friends and colleagues. He will be sadly missed. Rest in Peace

 **Ralph Holmes**, *President, International Pierre Gy Sampling Association*

I met Geoff Lyman for the first time at a sampling course I was presenting in New Castle Australia for the Australian Minerals Foundation. I was fascinated by Geoff's intellect when he was writing many equations on a napkin when taking breakfast and dinner together. Then we met Geoff again many times at the WCSB conferences, and other conferences as well. Geoff was an excellent cook and had a passion for sophisticated French Cuisine. At each conference he would select the best French restaurant in the visited region. Then we, I and my late wife Deloris, would join him at that restaurant and would share good food, outstanding wine, and good laughter.

Geoff had a superior intellect, and his dream was to simplify everything with advanced mathematics. Such simplifications did not always work too well with many people. Nevertheless, his suggestions were deep, often pertinent, and most certainly worthwhile careful considerations. His last book "Theory and Practice of Particulate Sampling, an Engineering Approach" was a brilliant achievement and I had the great pleasure to review the book several times prior to its publication. Doing that work for my good friend, I often struggled with the so-called "mathematical simplifications". Geoff was a good man. He was a perfectionist in everything he did. If you find something you can do with passion, you don't need to work anymore, as work becomes an immense pleasure. He definitely radiated that way of living, that way of thinking, and that way of loving. What a great man!

 **Francis F. Pitard**

Geoff's passing was very sad news. He made a significant impact on our work by helping us to obtain much-needed equipment and practices to help with our sampling processes. Personally, he answered all of my questions with fervor and respect (even the really basic ones) and helped me reach a much better understanding of the broad areas of Sampling Theory as well as the operational aspects of proper sampling. He had a very healthy skeptical view of the "establishment" while holding great respect and energy for the topic of sampling. I can't think of any other colleague that would be excited to climb up over 20 m on a metal ladder at -300C in the middle of February on the wind-swept Canadian Prairies in order to view a sampler in action; Geoff did it with a (frozen) smile on his face, in a borrowed jacket and mitts, right after arriving from summer in Australia. He will be missed.

 **Sheryl Tittlemier**

I knew and interacted with Geoff Lyman exclusively through the IPGSA community, in particular through nearly all WCSB's since WCSB2, Brisbane (2005). Geoff showed great interest in presenting his life-long work of further development of the Theory of Sampling (TOS), which he regarded only as a starting point. At a series of conferences, he presented increasingly more fully developed aspects of his view of what a theory of sampling *should* be: from a strict Poisson distribution point of departure, he developed a heavy mathematical-statistical avenue towards deriving 'the full sampling distribution' (Lyman) - as opposed to 'merely the moments' hereof (Pierre Gy). In his command of the necessary mathematics and statistics he was quite simply *brilliant*, as witnessed by what was to be the culmination and the academic pinnacle of his work as three seminal publications: a monumental textbook, and two high-level papers published in the prestigious journal MINERALS just before he passed away. Serving in various roles within the world sampling community, I had occasion to interact with Geoff as editor of the Proceedings from many WCSB conferences. It was not easy being an editor when a paper from his hand appeared on your desk. He would have no reviewer criticism of his work "if it did not include what I should write instead". Also, on many occasions I came to well-earned desperation when (first) he flatly refused invitations, (then) *ditto* stronger exhortations, and lastly threats of rejection - if he did not at least *tried* to describe in more clear text what his hallmark dense mathematical derivations actually meant physically etc. This was also the case regarding his two last papers in MINERALS, for which at one time no less than seven reviewers were involved causing quite some academic gun smoke. Still, this is but the academic way, an important part of how science progresses. In the end, at the next physical encounter(s), we usually all met friendly enough in the bar and downed quite a few ... although with Geoff it was distinctly better calling up good wine and food. From the realm of the IPGSA, a personal highpoint for him was receiving the prestigious Pierre Gy Sampling Gold Medal, Beijing, May 2019, the highest recognition for sampling science and education.

Geoff Lyman, close to the most brilliant of us, and certainly the brashiest - we will miss you thoroughly.

 **Kim H. Esbensen**





**Fig. 2:** *The Pierre Gy Sampling Medal being awarded to a proud Dr. Geoff Lyman in 2019. Photo used with permission by WCSB9 committee.*

Geoff is gone. Just like that. How sad. It was fun to have him around. He may have disliked the French, but he did love at least their food and could show it emphatically! And what a loss to our sampling community: he was always producing interesting material and ideas, with his mathematical derivations at which he excelled so much, to the point he sometimes missed the forest for the tree. He had indeed put his finger on a potentially important point in his latest publications that may one day prove decisive in advancing TOS models, but tragically, he did not realize it on time. We will follow suit and give him all the deserved credits when the time comes. Geoff also had a dream: modelling segregation in equations. This one will be much harder to follow on... Some things cannot be solved with maths. But we will try. We owe it to him. Adieu, Geoff!

**“ Dominique Francois-Bongarcon**

J'ai malheureusement rencontré Geoff trop tardivement pour profiter pleinement de ses connaissances très étendues et de ses idées de simplification et d'extension de la théorie de l'échantillonnage, qu'il avait le souci et le plaisir de transmettre. Malgré tout, les quelques discussions que nous avons pu avoir nous ont rapproché sur le plan scientifique, que ce soit dans les domaines de l'échantillonnage, du bilan matière ou de la libération minérale.

Sa bonne humeur et son franc-parler ne me font que regretter sa disparition bien trop prématurée et le fait de n'avoir pu développer une amitié au-delà d'une entente sur le plan des idées. Il m'avait fait l'honneur de revoir ses derniers articles avant publication et ce fut l'occasion de derniers échanges toujours aussi fructueux.

**“ Stephane Brochot**

Having sat in on many a WCSB conferences listening to many IPGSA members, honing my own layman's knowledge of sampling, I was never able to follow Jeff's presentations, but this is due more to my tuning out anything mathematical than Jeff's prowess on the topic. It was not until the conference in Beijing that I got to know the other side of Jeff, a more down to earth, relatable, and even funny Jeff. Several people have mentioned his love of French food and wine. It went further than that as he talked about his love of preparing dinner parties for large groups of friends at his home—there was no sign of the sampling genius in our conversations—just someone who enjoyed the social aspect of being with friends. I am glad I had the opportunity to see his softer side. I am sure he is indulging in a good bottle of wine and preparing a feast on the other side. After all he went through in his last year, he deserves to celebrate the life he had – Rest in peace Geoff.

**“ Anne Jodon Cole**

## Editor's curated selection of Geoff Lyman's scientific and technological impact and achievements:

### 1. "Sampling Particulate Materials – Recent Advances"



Geoff Lyman, AusIMM NZ Branch & RSC

[youtu.be/bNlJtJMj1pc](https://youtu.be/bNlJtJMj1pc)

### 2. Geoffrey Lyman's pinnacle academic achievement, self-published textbook (2019):

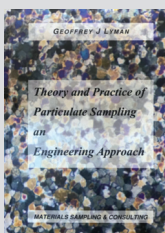

"Theory and Practice of Particulate Sampling an Engineering Approach"

Materials Sampling & Consulting, 2019

ISBN: 9781646333820

### 3. Brilliant attempt to resolve the decade long inferior cross-belt sampling enigma:

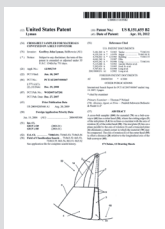

CROSS-BELT SAMPLER FOR MATERIALS CONVEYED ON A BELT CONVEYOR

United States Patent

Patent No.: US 8,151,655 B2

Date of Patent: Apr. 10, 2012

### 4. Latest two papers, published in MINERALS just two months before the Author's passing:



A Statistical Theory for Sampling of Particulate Materials

Minerals 2023, 13(7), 905; <https://doi.org/10.3390/min13070905>

Sampling Theory for Mineral Process Flows

Minerals 2023, 13(7), 922; <https://doi.org/10.3390/min13070922>

## Contributors



### Dominy, Simon C.

Dr Simon Dominy is a mining geologist-engineer with over 25 years' experience based in operations, consulting and academia. He has a background in mine operations and technical/leadership roles, with multi-commodity and continent experience. He has worked across the mine value chain from project studies, through to mine reopening/development and operations. Simon is an acknowledged expert in the evaluation and exploitation of coarse gold-bearing high-nugget effect deposits. He has designed and managed numerous studies relating to geometallurgy; resource development; sampling protocol optimisation; bulk sampling programmes; resource/reserve estimation; and grade control. He has authored numerous technical reports (JORC 2012 and NI 43-101), and peer reviewed journal and conference papers. He is a Visiting Associate Professor at the Camborne School of Mines, University of Exeter, UK, and holds technical/advisory positions with Novo Resources Corp., Artemis Resources Ltd, Puma Exploration Inc., and OCX Gold Group. In 2022, Simon was awarded the Pierre Gy Sampling Gold Medal by the IPGSA.

✉ [s.dominy@e3geomet.com](mailto:s.dominy@e3geomet.com)

in <https://www.linkedin.com/in/scdominy/>

id <https://orcid.org/0000-0002-0638-3693>



### Esbensen, Kim H.

Dr Kim H. Esbensen has been research professor in Geoscience Data Analysis and Sampling at GEUS, the National Geological Surveys of Denmark and Greenland (2010–2015), chemometrics and sampling professor at Aalborg University, Denmark (2001–2015), professor (Process Analytical Technologies) at Telemark Institute of Technology, Norway (1990–2000 and 2010–2015). From 2015 he phased out a 35 year academic career for a new quest as consultant and independent researcher. But as he could not terminate his love for teaching, he is regularly active as an international visiting, guest and affiliate professor. A geologist/geochemist/metallurgist/data analyst of training, he has been working 20+ years in the forefront of chemometrics, but since 2000 has devoted most of his R&D to the theme of representative sampling of heterogeneous materials, processes and systems: Theory of Sampling (TOS), PAT (Process Analytical Technology) and chemometrics. He is a member of several scientific societies and has published over 250 peer-reviewed papers and is the author of a widely used textbook in Multivariate Data Analysis, which was published in its 6th edition in 2018. He was chairperson of the taskforce behind the world's first horizontal (matrix-independent) sampling standard DS3077 (2013), 3.rd.ed. soon to be inducted as an ISO standard. In 2020 he published the foundational „Introduction to the Theory and Practice of Sampling“. Since 2013, he was editor of TOS forum and Spectroscopy Europe/World „Sampling Column“, from 2024 amalgamated and metamorphosed into „Sampling Science and Technology (SST).

✉ [khe.consult@gmail.com](mailto:khe.consult@gmail.com)

id <https://orcid.org/0000-0001-6622-5024>



### **Francois-Bongarçon, Dominique**

Dominique François-Bongarçon graduated as a Mining Engineer and holds a Doctorate in Mining Sciences and Techniques at the Geostatistics Center from the Paris School of Mines (Paris Tech). He has more than 40 years of experience in the mining industry and works as a consultant in earth sciences for his own company, Agoratek International Consultants Inc., based in Canada. In 1992 he embarked on a career-long research in Gy's theory of sampling, and he worked with Pierre Gy as a consultant and on training courses. He contributed to the onset of the WCSB cycle of conferences (2003). In 2009, he was the recipient of the Pierre Gy Sampling Gold Medal. In recent times, he has been continuing his research in Sampling Theory, in the techniques and spirit of the QA-QC discipline and on mine-mill reconciliations. He is also making new advances in the handling of extreme grades in Geostatistics.

✉ [dfbgn2@gmail.com](mailto:dfbgn2@gmail.com)



### **Graham, Janice C.**

Janice C. Graham has over 16 years' experience working in the mining industry, gaining experience in a variety of commodities and deposits, using different mining software packages (Datamine, Supervisor, and Vulcan). Jan has experience in training, mining software application, designing grade control systems, geological modelling, macro writing, technical report writing, auditing and technical reviews, and resource estimation including advanced estimation techniques. She has authored technical reports to JORC 2012 and NI43-101 standards. Jan holds a BSc degree in geology from the University of Plymouth, UK, and an MSc in Mining Geology from the Camborne School of Mines, UK. She is currently a Principal Resource Geologist with Snowden Optiro based in Perth, Australia.

✉ [jan.graham@snowdenoptiro.com](mailto:jan.graham@snowdenoptiro.com)



### **Paoletti, Claudia**

Claudia Paoletti did her Master in Biological Science at the University of Rome (Italy) and her PhD in Plant Genetics at the University of Connecticut, USA. She was for three years at Dalhousie University (Canada) studying plant population genetics and biometry. She continued her activity at the Research Institute for Industrial Crops in Bologna (Italy) where she focused on the evaluation of the risks of transgenic crops. In January 2006 she joined the GMO Unit of the European Food Safety Authority (EFSA) first as Team Leader and then as Deputy Head of the Unit. In 2019 she was appointed manager of the programme designed to reorganise the EFSA in preparation for the new European Law on food safety. She has been the Italian expert for the definition of the European Commission sampling plans for GMO detection in conventional seeds. She coordinated the European sampling research project KeLDA and she has been the biometric officer of the EU Community Reference Laboratory for GMOs. She is expert consultant for ISO/IWA committees, OECD, CEN, the European Commission and FAO. She organised international training courses on food/ feed safety for the European Commission, UNIDO, PHARE project and universities within and outside Europe. She has over 90 contributions either as book chapters, or as peer-reviewed papers.

✉ [claudia.paoletti@efsa.europa.eu](mailto:claudia.paoletti@efsa.europa.eu)



### Purevgerel, Saranchimeg

Sara Purevgerel has experience in exploration, resource development and mining investment across commodities including coal, copper-gold, copper, gold, fluorite, and iron ore. She has over 17 years' experience in technical assessment and reporting, mineral project evaluation, feasibility studies, sampling and QAQC, and technical management. She holds an MBA in mining from the Mongolian University of Science and Technology, and an MSc in mineral economics from the Western Australian School of Mines, Curtin University. Sara is currently Director/Principal of MSA Global LLC and sits on several professional committees, including MONVAL and CRIRSCO.

✉ [saranchimeg.pu@gmail.com](mailto:saranchimeg.pu@gmail.com)

🆔 <https://orcid.org/0000-0003-0625-9518>



### Rawle, Alan

Alan Rawle has had around almost 50 years' experience in various aspects of science and technology. Alan has a degree in industrial chemistry and a Ph.D in supported alloy catalysts both acquired at Brunel University, London, UK. Since 1990, Alan has been with Malvern Instruments as the Applications Manager based in Westborough, MA, USA since 2003. He is still working part-time with Malvern Panalytical.

Dr. Rawle was (2005 – 2022) CoChair of E 56.02, the Characterization SubCommittee of the ASTM E56 Committee on Nanotechnology. He was the Technical Author (i.e. writer) for ASTM standards in particle size, zeta potential, size distribution calculation among others. Dr. Rawle is also a Fellow of the Royal Society of Chemistry (FRSC), a Distinguished Fellow of the International Engineering and Technology Institute (DFIETI), and a regular contributor to ResearchGate.

✉ [alan.rawle@malvernpanalytical.com](mailto:alan.rawle@malvernpanalytical.com)

🌐 <https://www.linkedin.com/in/alanrawle/>



### Vogel, Duncan A.

Duncan Aldwin Vogel is a global expert in weighing, sampling and testing of traded commodities. Already during his study in business management at the International School of Economics, Rotterdam, Aldwin started building his pedigree in the renowned family inspection business Hoff & Co. Services BV that became part of Bureau Veritas in 2010. From 2011 to 2013 Aldwin was based in Houston, USA for BV as acting Director, Steel and Energy Products. From 2013 to 2022 he was responsible for BV Commodities Global Service Line as Director Technical Governance. In 2022 Aldwin changed from the large corporate multinational to return to an agile family-owned organisation, to earning trust and keeping his international client focus as Regional General Manager Europe for Alfred H. Knight. Most recently in 2023 launching a TOS compliant SamplingHub for circular commodity: Incinerator Bottom Ashes.

His expertise covers all aspects of inspection, sampling and analysis starting from green field prospect requirements to fully implemented turn-key projects. Embracing the Theory of Sampling (TOS) to the fullest, augmented inspection services through IoT and smart communication. He is highly experienced at all aspects of testing for Transportable Moisture Limit and was leader of the TML workgroup of the TIC Council.

✉ [aldwin.vogel@ahkgroup.com](mailto:aldwin.vogel@ahkgroup.com)

🆔 <https://orcid.org/0000-0003-0445-5259>

## How to contribute

Sampling Science and Technology (SST) serves as a collaborative platform fostering scientific and technological engagement within the global sampling community. Our primary objective is to have a significant educational impact, catering to various levels of interest.

SST embraces didactic studies, practical insights, illustrative case histories, and occasional theoretical articles tailored for the sampling community in both strict and broad senses. Your valuable contributions play a pivotal role in our mission to cultivate professional sampling competence across diverse societal sectors where sampling holds significance — spanning science, technology, industry, trade, food/feed, public health, and more.

Papers in Sampling Science & Technology (SST) are published under a Creative Commons license. Using the CC BY-SA license we make sure that credit must be given to the authors and adaptations must be shared under the same terms.

More information regarding this license can be found here: <https://creativecommons.org/licenses/by-sa/4.0/legalcode.en>

If you are interested in contributing to SST, we provide all the necessary information about article format specifications and guidelines as well the mandatory publication agreement as downloadable documents on our website at [sst-magazine.info/contribute](https://sst-magazine.info/contribute).

If you have scientific questions regarding a contribution, please contact the Editor-in-chief at [khe.consult@gmail.com](mailto:khe.consult@gmail.com).

## IMPRINT

Sampling Science and Technology (SST) is an open access publication by the International Pierre Gy Sampling Association (IPGSA). The magazine is published biannually in digital form. Visit [sst-magazine.info](https://sst-magazine.info) and [intsamp.org](https://intsamp.org) for details.

### Editorial Staff

**Editor-in-Chief:** Kim H. Esbensen, V.i.S.d.P (Person responsible according to the German Press Law)  
E-mail: [khe.consult@gmail.com](mailto:khe.consult@gmail.com)

**Editorial Asst.:** ReConsider (Anne J. Cole, PhD)  
E-mail: [anne@reconsideredit.com](mailto:anne@reconsideredit.com)

**Contributors:** Simon C. Dominy  
Kim H. Esbensen  
Dominique Francois-Bongarcon,  
Janice C. Graham,  
Claudia Paoletti  
Saranchimeg Purevgerel  
Alan Rawle  
Duncan A. Vogel

**Advertising Sales and Sponsorship Coordination:**  
Benedikt Dolzer and Kim H. Esbensen  
E-mail: [advertisement@sst-magazine.info](mailto:advertisement@sst-magazine.info)

### Publisher

Benedikt Dolzer · 

© 2024 Benedikt Dolzer · bd verlag  
Benedikt Dolzer, Wilbankstraße 141,  
D-52076 Aachen, Germany  
Phone: +49 2408 93 80 999  
E-mail: [sss@bd-verlag.de](mailto:sss@bd-verlag.de)

The consent of the publisher is required for reprinting.

Contributions marked by name do not necessarily reflect the opinion of the editorial team. The publisher assumes no liability for unsolicited submissions of any kind.

Articles in Sampling Science & Technology (SST) are published using the CC BY-SA license. You are free to copy and redistribute the material in any medium or format for any purpose, even commercially and free to remix, transform, and build upon the material for any purpose, even commercially. You must give appropriate credit, provide a link to the license, and indicate if changes were made. You may do so in any reasonable manner, but not in any way that suggests the licensor endorses you or your use. If you remix, transform, or build upon the material, you must distribute your contributions under the same license as the original.

If an article includes an image that was used with permission, or as fair use, the CC license will only apply to the author's original content, not that image.



**IPGSA**  
INTERNATIONAL  
PIERRE GY  
SAMPLING ASSOCIATION

# WCSB11

THE 11<sup>TH</sup> WORLD CONFERENCE  
OF SAMPLING AND BLENDING

21-23 MAY 2024

HYBRID CONFERENCE  
MISTY HILLS CONFERENCE CENTRE  
MULDERSDRIFT, JOHANNESBURG  
SOUTH AFRICA



The World Conference on Sampling and Blending (WCSB), to be held in South Africa, 21–23 May 2024, is the eleventh such conference to promote the Theory of Sampling (TOS). The WCSB conference provide a meeting place for professionals interested in sampling theory, practice, experience, applications, and standards. The Conference will provide understanding and insights for academics, manufacturers, engineering firms and practitioners aiming to achieve representative sampling. TOS effectively identifies the source of sampling variability and provides valuable solutions for minimising each source of sampling uncertainty.

The aim of WCSB11 is to invite and encourage the diverse international sampling community to adopt and disseminate the concepts and ideas for a standardized approach to sampling embodied in the TOS. The Conference will also offer a forum for fruitful discussions between statisticians committed to 'Measurement of Uncertainty' (MU) and proponents of the TOS by offering a unifying foundation for development of better and more general standards. While the Theory of Sampling had its historical origins in the mining industry, today it also applies to sampling of a broad range of bulk materials, minerals, agricultural raw materials and products, the food, feed, and pharmaceutical industries, as well as sampling for environmental applications.

WCSB11 is an event of global significance that aims to improve sampling practices in all sectors of science, technology, and industry, for consultants, managers, sampling and quality control staff, researchers, engineers, and manufacturers operating in many industries. The opportunity to meet, exchange ideas, and share practical experiences will be a significant benefit for attendees.

The proceedings of the Conference will be published in electronic format with a strict adherence to an editorial and peer review policy that will allow academics to attract the publication subsidy for published academic research. The Pierre Gy Gold Medal is awarded at each WCSB conference to individuals who have been most effective and successful around the world in disseminating and promoting TOS. This achievement will again be celebrated at WCSB11. The medallists are a unified body of champions capable of teaching, promoting, and researching aspects of sampling theory and practice, supporting the efforts of original equipment manufacturers to uphold TOS rules of sample representativeness.

WCSB conferences aim to develop a unified vision for specific quality control protocols for sampling and blending activities, with participation and collaboration of industry professionals.



## Introduction to the Theory and Practice of Sampling

by K.H. Esbensen

IMP Open, Chichester, UK (2020)

ISBN: 978-1-906715-29-8

DOI: 10.1255/978-1-906715-29-8

Price: £ 69.00

[store.impopen.com/introduction-to-the-theory-and-practice-of-sampling.html](https://store.impopen.com/introduction-to-the-theory-and-practice-of-sampling.html)

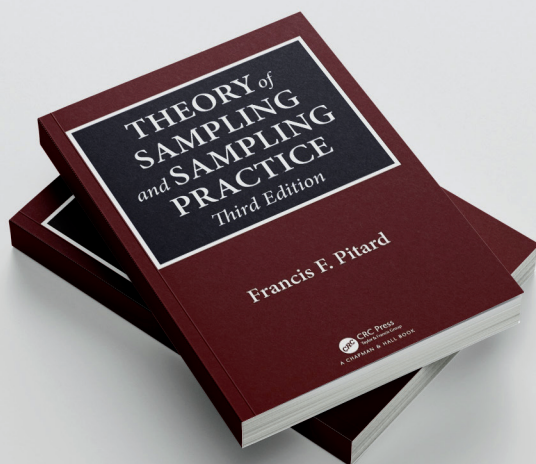

## Theory of Sampling and Sampling Practice, 3rd Ed.

by F.F. Pitard

CRC Press, Taylor & Francis Group (2019)

ISBN: 978-1-138-47648-6

DOI: 10.1201/97811351105934

Price: US\$ 260.00

[amazon.com/dp/113847648X](https://amazon.com/dp/113847648X)



## Theory and Practice of Particulate Sampling: an Engineering Approach

by Geoffrey J. Lyman

Materials Sampling & Consulting (2019)

ISBN: 978-164633382-0

Price: AUD 405.00

[materials-sampling-and-consulting.com/Textbook](https://materials-sampling-and-consulting.com/Textbook)